

OPERATOR MANUAL

IMPORTANT INFORMATION, KEEP FOR OPERATOR
This manual provides information for:

smartsteam™

BOILERLESS STEAMER 100

MODELS SSB-3G/5G/10G & (2)SSB-3G/5G/10G Domestic SMARTSTEAM100™ BOILERLESS STEAMER

- Self Contained
- Gas Heated
- Capacity: SSB-3G=3 Steamer Pans Per Cavity
SSB-5G=5 Steamer Pans Per Cavity
SSB-10G=10 Steamer Pans Per Cavity



THIS MANUAL MUST BE RETAINED FOR FUTURE REFERENCE. READ, UNDERSTAND AND FOLLOW THE INSTRUCTIONS AND WARNINGS CONTAINED IN THIS MANUAL.

FOR YOUR SAFETY

Do not store or use gasoline or other flammable vapors and liquids in the vicinity of this or any other appliance.

POST IN A PROMINENT LOCATION

Instructions to be followed in the event user smells gas. This information shall be obtained by consulting your local gas supplier. As a minimum, turn off the gas and call your gas company and your authorized service agent. Evacuate all personnel from the area.

WARNING

Improper installation, adjustment, alteration, service or maintenance can cause property damage, injury or death. Read the installation, operating and maintenance instructions thoroughly before installing or servicing this equipment.

NOTIFY CARRIER OF DAMAGE AT ONCE

It is the responsibility of the consignee to inspect the container upon receipt of same and to determine the possibility of any damage, including concealed damage. Unified Brands suggests that if you are suspicious of damage to make a notation on the delivery receipt. It will be the responsibility of the consignee to file a claim with the carrier. We recommend that you do so at once.

Manufacture Service/Questions 888-994-7636.

Information contained in this document is known to be current and accurate at the time of printing/creation. Unified Brands recommends referencing our product line websites, unifiedbrands.net, for the most updated product information and specifications.

PART NUMBER 145144, REV. F (05/07)

GROEN®

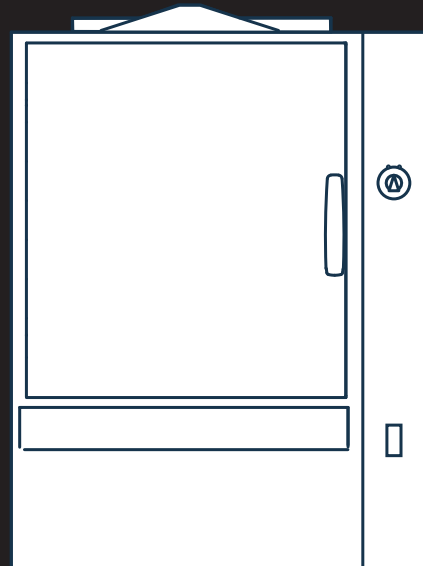

1055 Mendell Davis Drive
Jackson, MS 39272
888-994-7636, fax 888-864-7636
groen.com

IMPORTANT — READ FIRST — IMPORTANT

- WARNING:** THE UNIT MUST BE INSTALLED BY PERSONNEL QUALIFIED TO WORK WITH ELECTRICITY AND PLUMBING. IMPROPER INSTALLATION CAN CAUSE INJURY TO PERSONNEL AND/OR DAMAGE TO THE EQUIPMENT. THE UNIT MUST BE INSTALLED IN ACCORDANCE WITH APPLICABLE CODES.
- CAUTION:** SHIPPING STRAPS ARE UNDER TENSION AND CAN SNAP BACK WHEN CUT.
- CAUTION:** DO NOT INSTALL THE UNIT IN ANY WAY WHICH WILL BLOCK THE REAR VENTS, OR WITHIN 2 INCHES OF A HEAT SOURCE SUCH AS A BRAISING PAN, DEEP FRYER, CHAR BROILER OR KETTLE.
- CAUTION:** LEVEL THE UNIT FRONT TO BACK, AND PITCH IT SLIGHTLY TO THE FRONT, TO AVOID DRAINAGE PROBLEMS.
- WARNING:** FOLLOW THE WIRING DIAGRAM EXACTLY WHEN CONNECTING A UNIT TO AVOID DAMAGE OR INJURY. WIRING DIAGRAM IS LOCATED ON THE INSIDE OF THE RIGHT PANEL.
- CAUTION:** DO NOT USE PLASTIC PIPE. DRAIN MUST BE RATED FOR BOILING WATER.
- WARNING:** DO NOT CONNECT THE DRAIN DIRECTLY TO A BUILDING DRAIN.
- WARNING:** BLOCKING THE DRAIN IS HAZARDOUS.
- IMPORTANT:** IMPROPER DRAIN CONNECTION WILL VOID WARRANTY.
- IMPORTANT:** DO NOT ALLOW ANY WATER TRAPS IN THE DRAIN LINE. A TRAP CAN CAUSE PRESSURE TO BUILD UP INSIDE THE CAVITY DURING STEAMING, WHICH WILL MAKE THE DOOR GASKET LEAK.
- WARNING:** WHEN YOU OPEN THE DOOR, STAY AWAY FROM STEAM COMING OUT OF THE UNIT. STEAM CAN CAUSE BURNS.
- WARNING:** BEFORE CLEANING THE OUTSIDE OF THE STEAMER, DISCONNECT THE ELECTRIC POWER SUPPLY. KEEP WATER AND CLEANING SOLUTIONS OUT OF CONTROLS AND ELECTRICAL COMPONENTS. NEVER HOSE OR STEAM CLEAN ANY PART OF THE UNIT.
- WARNING:** ALLOW COOKING CHAMBER TO COOL COMPLETELY BEFORE CLEANING.
- WARNING:** USE MILD CLEANING AGENTS ONLY. CAREFULLY READ THE WARNINGS AND FOLLOW THE DIRECTIONS ON THE LABEL OF EACH CLEANING AGENT. USE SAFETY GLASSES AND RUBBER GLOVES AS RECOMMENDED BY CLEANING AGENT MANUFACTURER.
- WARNING:** DO NOT PUT HANDS OR TOOLS INTO THE COOKING CHAMBER UNTIL THE FAN HAS STOPPED TURNING.
- WARNING:** DO NOT OPERATE THE UNIT UNLESS THE REMOVABLE RIGHT SIDE PANEL HAS BEEN RETURNED TO ITS PROPER LOCATION.
- NOTICE:** DO NOT USE A CLEANING AGENT THAT CONTAINS ANY SULFAMIC ACID, OR ANY CHLORIDE, INCLUDING HYDROCHLORIC ACID. IF THE CHLORIDE CONTENT OF ANY PRODUCT IS UNCLEAR, CONSULT THE MANUFACTURER. DO NOT USE A CLEANING OR DELIMING AGENT THAT CONTAINS MORE THAN 30% PHOSPHORIC ACID.
- NOTICE:** DO NOT USE ANY DEGREASER THAT CONTAINS POTASSIUM HYDROXIDE OR SODIUM HYDROXIDE OR THAT IS ALKALINE.
- WARNING:** USE OF ANY REPLACEMENT PARTS OTHER THAN THOSE SUPPLIED BY GROEN OR THEIR AUTHORIZED DISTRIBUTOR VOIDS ALL WARRANTIES AND CAN RESULT IN BODILY INJURY TO THE OPERATOR AND DAMAGE THE EQUIPMENT. SERVICE BY OTHER THAN FACTORY-AUTHORIZED PERSONNEL WILL VOID ALL WARRANTIES.
- WARNING:** HIGH VOLTAGE EXISTS INSIDE CONTROL COMPARTMENTS. DISCONNECT FROM BRANCH CIRCUIT BEFORE SERVICING. FAILURE TO DO SO CAN RESULT IN INJURY OR DEATH.

Table of Contents

OPERATOR WARNINGS.....	2
REFERENCES.....	3
EQUIPMENT DESCRIPTION.....	4
INSPECTION AND UNPACKING	4
INSTALLATION AND STARTUP	5
OPERATION	9
CLEANING.....	11
MAINTENANCE.....	13
TROUBLESHOOTING.....	13
SERVICE LOG.....	15
WARRANTY PROTECTION	16

References

UNDERWRITERS LABORATORIES, INC.
333 Pfingsten Road
Northbrook, Illinois 60062

NFPA/70 The National Electrical Code

NATIONAL SANITATION FOUNDATION
3475 Plymouth Road
Ann Arbor, Michigan 48106

NATIONAL FIRE PROTECTION ASSOCIATION
60 Batterymarch Park
Quincy, Massachusetts 02269

NFPA/ 54 The National Fuel Gas Code

Equipment Description

Your Groen SSB-3G/5G/10G or (2)SSB-3G/5G/10G SmartSteam100 Boilerless Steamer is designed to give years of service. It has a stainless steel cavity (cooking chamber) which is served by a gas-heated atmospheric steam generating reservoir. A powerful blower circulates the steam in the cavity to increase heating efficiency.

Each cavity holds up to three, five or ten steam table pans (12" x 20" x 2 1/2" deep) as shown below.

SSB Steamer	PANS PER CAPACITY PER TYPE			
	12 x 20 x 2-1/2 (steamer)	12 x 20 x 4 (steamer)	13 x 18 (half size bake)	18 x 26 (bake)
SSB-3G	3	2	0	0
(2)SSB-3G	6	4	0	0
SSB-5G	5	3	0	0
(2)SSB-5G	10	6	0	0
SSB-10G	10	6	20	10
(2)SSB-10G	20	12	40	20

An 18-gauge stainless steel case encloses the cavity, the steam generating reservoir and the control compartment that houses electrical components. Door hinges are field-reversible (the door may be set to open from the left or right). Operating controls are on the front panel.

The SSB- 3G/5G/10G steamers are equipped with electronic controls. These units are readily identified by their unique control panels. Steamer function is controlled by touch pad controls and a rotary timer dial.

The drain system on all models includes a spray condenser, which cools drain water.



Inspection and I

Your Groen SmartSteam100 Boilerless Steamer will be delivered completely assembled in a heavy shipping carton strapped to a skid. On receipt, inspect carton carefully for exterior damage.

CAUTION
SHIPPING STRAPS ARE UNDER TENSION AND CAN SNAP BACK WHEN CUT.

Carefully cut the straps and detach the sides of the carton from the skid. Pull the carton up off the unit. Be careful to avoid personal injury or equipment damage from staples which might be left in the carton walls.

When starting installation, check packing materials to make sure loose parts such as the condensate drip tray are not discarded with this material.

SSB Steamer	Weight (LBS)	Weight (KGS)
SSB-3G Table Top	240	109
SSB-3G W/Stand	310	141
(2) SSB-3G W/Stand	475	215
SSB-5G Table Top	272	123
SSB-5G W/Stand	345	156
(2)SSB-5G W/Stand	555	252
SSB-10G W/Stand	452	205
(2)SSB-10G W/Stand	764	347

Write down the model number, serial number and installation date. Keep this information for reference. Space for these entries is provided at the top of the Service Log in the back of this manual.

Installation and Startup

WARNING

THE UNIT MUST BE INSTALLED BY PERSONNEL WHO ARE QUALIFIED TO WORK WITH GAS, ELECTRICITY AND PLUMBING. IMPROPER INSTALLATION CAN CAUSE INJURY TO PERSONNEL AND/OR DAMAGE TO THE EQUIPMENT. THE UNIT MUST BE INSTALLED IN ACCORDANCE WITH APPLICABLE CODES. THE UNIT MUST BE INSTALLED BY A LICENSED PLUMBER OR GAS FITTER WHEN INSTALLED WITHIN THE COMMONWEALTH OF MASSACHUSETTS.

CAUTION

DO NOT INSTALL THE UNIT WITH THE REAR VENTS BLOCKED OR WITHIN 2 INCHES OF A HEAT SOURCE SUCH AS A BRAISING PAN, DEEP FAT FRYER, CHARBROILER OR KETTLE.

TO AVOID DRAINAGE PROBLEMS, LEVEL THE UNIT FRONT TO BACK, AND PITCH SLIGHTLY TO THE FRONT.

1. Installation

Minimum Clearances: SmartSteam100 Boilerless Steamer requires the following minimum clearances to any surface, combustible or non-combustible.

Right Side	2 inches
Left Side	2 inches
Rear	6 inches

Steam Free Zone: The SmartSteam100 Boilerless Steamer can be damaged by steam from external sources. **Do not install** the steamer over a steam venting drain. Ensure that steam is not present in an area bounded by the footprint of the steamer and a circle 18 inches in radius about the right rear corner of the steamer (see figure below).

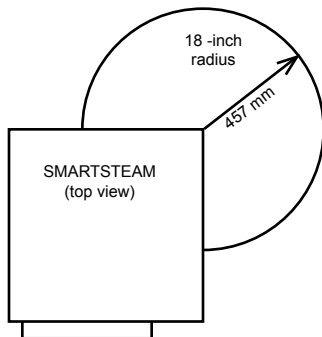

Install and operate the gas appliance in a well ventilated area. Adequate air must be supplied to replenish the air used for combustion. Installation must conform with local codes and/or with the National Fuel Gas Code, ANSI Z223.1/NFPA-54 (latest edition) or the National Gas and Propane Code CSA B149.1 as applicable.

Any item which might obstruct or restrict the flow of air for combustion and ventilation must be removed. Do not obstruct the flue cover or rear vents after installation.

THE AREA DIRECTLY AROUND THE APPLIANCE MUST BE CLEARED OF ALL COMBUSTIBLE MATERIAL. FAILURE TO FOLLOW THESE INSTRUCTIONS CAN CAUSE BODILY INJURY AND/OR PROPERTY DAMAGE.

The steamer must be **disconnected** from the gas supply system during any pressure testing of that system which has test pressures in excess of $\frac{1}{2}$ PSI (3.45 kPa).

2. Electrical Supply Connection

Provide 115 VAC, 60 HZ, 1 PH, 15 AMP service. Bring wire in through hole in the lower left back panel. Each cavity requires a separate cord for connections. Local codes and/or the National Electrical Code should be observed in accordance with ANSI/NFPA 70. **AN ELECTRICAL GROUND IS REQUIRED.** The wiring diagram is located in the service compartment and in this manual. Maximum load is $2\frac{1}{2}$ AMPs. In Canada, provide electrical service in accordance with the Canadian Electrical Code, CSA C22.2 Part 1 and/or local codes.

3. Gas Supply Connection

Connection to the gas supply shall be in accordance with the chart below.

SSB-Steamer	NPT Pipe Size Required
SSB-3G	$\frac{1}{2}$
(2)SSB-3G	$\frac{1}{2}$
SSB-5G	$\frac{1}{2}$
(2)SSB-5G	$\frac{1}{2}$
SSB-10G	$\frac{3}{4}$
(2)SSB-10G	$\frac{3}{4}$

Ratings for Gas SmartSteam100

*Measured on top of gas valve

	BTU	*Operating Pressure	MIN Incoming Gas Feed Rate	MAX Incoming Gas Feed Rate
3G NG	54,000	4.30" WC	5" WC	14" WC
3G LP	54,000	10.5" WC	12" WC	14" WC
5G NG	62,000	4.25" WC	5" WC	14" WC
5G LP	62,000	10.5" WC	12" WC	14" WC
10G NG	106,000	4.30" WC	5" WC	14" WC
10G LP	106,000	10.5" WC	12" WC	14" WC

In Canada, the installation must conform to the Canadian Gas Code, CAN 1-B149, Installation Codes for Gas Burning Appliances and Equipment and/or local codes.

After the unit has been connected to the gas supply, all gas joints must be checked for leaks. **Do NOT use flame checking for leaks.** A thick soap solution or other suitable leak detector should be used.

For a Unit on casters:

A. The installation shall be made with a connector that complies with the standard for connectors for movable gas appliances; ANSI Z21.69.CSA 6.16, and a quick-disconnect device that complies with the standard for quick-disconnect devices for use with gas fuel, ANSI Z21.41.CSA 6.9.

B. Adequate means must be provided to limit the movement of the appliance without depending on the connector and the quick-disconnect device or its associated piping to limit the appliance movement.

C. The location where the restraining device may be attached to the appliance shall be in accordance with Groen specifications for the device.

4. Water Connection(s)

Install a check valve to prevent back flow in the incoming cold water line, as required by local plumbing codes. Water pressure in the line should be between 30 and 60 PSI. If pressure is above 60 PSI, a pressure regulator will be needed. These pressures must provide the **1.5 gallons per minute** required for proper steamer function.

A 3/4 inch female NH connector (garden hose type) is used to attach the water supply to the inlet valve. **Minimum inside diameter of the**

water feed line is 1/2 inch. Use a washer in the hose connection. Do not allow the connection to leak, no matter how slowly. Do not over-tighten hose connections.

This equipment is to be installed to comply with the basic plumbing code of the Building Officials and Code Administrators International, Inc. (BOCA) and the Food Service Sanitation Manual of the Food and Drug Administration (FDA).

NOTE: Local code may also require check valves in the water supply line.

5. Drain Connection

Level the steamer front to back, and pitch it slightly to the rear (maximum 1/4 inch) by adjusting the optional legs or the bullet feet on the optional stand.

SSB-Steamer	Drain ID Hose Size Required (IN)
SSB-3G	1.5"
(2)SSB-3G	2.5"
SSB-5G	1.5"
(2)SSB-5G	2.5"
SSB-10G	2.0"
(2)SSB-10G	2.0"

WARNING:

DO NOT CONNECT THE DRAIN DIRECTLY TO A BUILDING DRAIN. BLOCKING THE DRAIN IS HAZARDOUS.

There must be a free air gap between the end of the hose and the building drain. The free air gap should be as close as possible to the unit drain. There must also be no other elbows or restrictions between the unit drain and the free air gap.

CAUTION

DO NOT USE PLASTIC PIPE. DRAIN MUST BE RATED FOR BOILING WATER.

Install the drain line with a constant downward pitch.

IMPORTANT: Do not allow water traps in the line. A trap can cause pressure in the cavity, which may cause the door gasket to leak.

Proper Drain Line Connection — Drain Line must have a constant downward pitch of at least 1/4" per foot. Observe local code regarding air gap spacing and drain connections.5.



IMPROPER DRAIN LINE CONNECTION

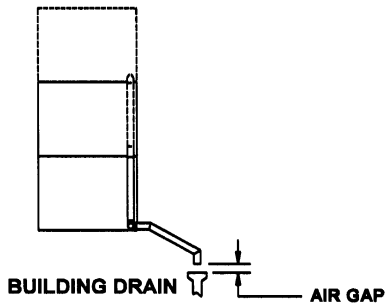

D. Drain Connection

Steamers must be leveled front to back, and pitched to the front (maximum $\frac{1}{4}$ inch) by adjusting the bullet feet on the cabinet or stand base.

For all factory-stacked SSB steamers, a 2 $\frac{1}{2}$ inch ID hose is attached to the unit drain. It must be rated for boiling water.

7. Counter-Mounted Units

This section is applicable if the steamer will be mounted to a counter. All four edges of the bottom of the steamer must be sealed with RTV to the counter if the 4 inch legs are not used. Counter must be made of a noncombustible material such as metal or tile.

6. Factory-Stacked Units

This section is applicable only if you are installing factory-stacked units.

Installing stacked steamers is similar to installing a single unit. The steamers are stacked and assembled at the factory and delivered with the water connections and drain hoses required for a single point connection.

A. Water Connection

The same water supply connection is used for both units. At the water inlet valve a $\frac{3}{4}$ inch female NH connector (garden hose type) is used for the water supply.

B. Electrical Supply Connection

Separate electrical connections will be required for each steamer to be stacked. Each steamer unit must have its own branch circuit protection.

C. Gas Connection

A single gas connection is required for both steamers. Gas supply must be adequate under all conditions as listed on page 6.

Initial Startup

After the SmartSteam100 Boilerless Steamer has been installed, test it to ensure that the unit is operating correctly.

1. Remove all literature and packing materials from the interior and exterior of the unit.
2. Make sure the water supply line is open.
3. Make sure that the gas supply line is open and that the manual knob on the main gas valve is turned to the ON position. This valve is at the rear on the right side of the unit.
4. Turn on electrical service to the unit. The steamer will not operate without electrical power. Do not attempt to operate the unit during a power failure.

NOTE: The door **MUST** be closed for the main burner to work.

5. To turn the unit on, press the ON switch on the control panel.
6. When the steam generating reservoir has filled with water, the main burners will ignite automatically. Within 20 minutes or less the READY light will come on, indicating that the water has reached its standby

temperature. When the READY light is displayed, you may take any one of the following steps;

- a. Push TIMED and set the timer knob to the desired steaming time.
- b. Push MANUAL for continuous steaming.
- c. Push STOP to let the unit stay at ready condition.



WARNING
WHEN YOU OPEN THE DOOR, STAY AWAY
FROM STEAM COMING OUT OF THE UNIT.
STEAM CAN CAUSE BURNS.

7. To shut down the unit, press the OFF switch. The steam generating reservoir will then fill with cold water and drain.
8. If the steamer operates as described, the unit is functioning correctly and ready for USE.

NOTE: For operation at high altitudes (2000 feet and above), please consult the Groen Foodservice Engineering Department.

Operation

A. Controls

Operator controls are on the front right of the unit.

The control panels have the following touch pads and indicator lights:

- The TIME display shows the remaining cooking time. It displays three dashes in MANUAL mode.
- The ON/OFF rocker switch gets the SmartSteam100 ready for use or shuts it off.
- The READY indicator light indicates the unit has achieved the ready temperature.
- Hour meter records cumulative hours of operation.
- The FAULT display shows the current fault.

The push button operations:

1. In the STOP mode the steam generator stays at a low boil or ready temperature.
2. When the TIMED button is pushed, the TIMED light will illuminate and time can be set by turning the TIMER knob (cook time can be increased or decreased at any time by turning the timer knob). The unit steams until the timer counts down to zero and the temperature drops to ready. At that time the STOP light illuminates and a beeper sounds.
3. When the MANUAL button is pushed the unit steams continuously. The MANUAL light will stay illuminated.
4. CANCEL button should be pushed to stop beeping.

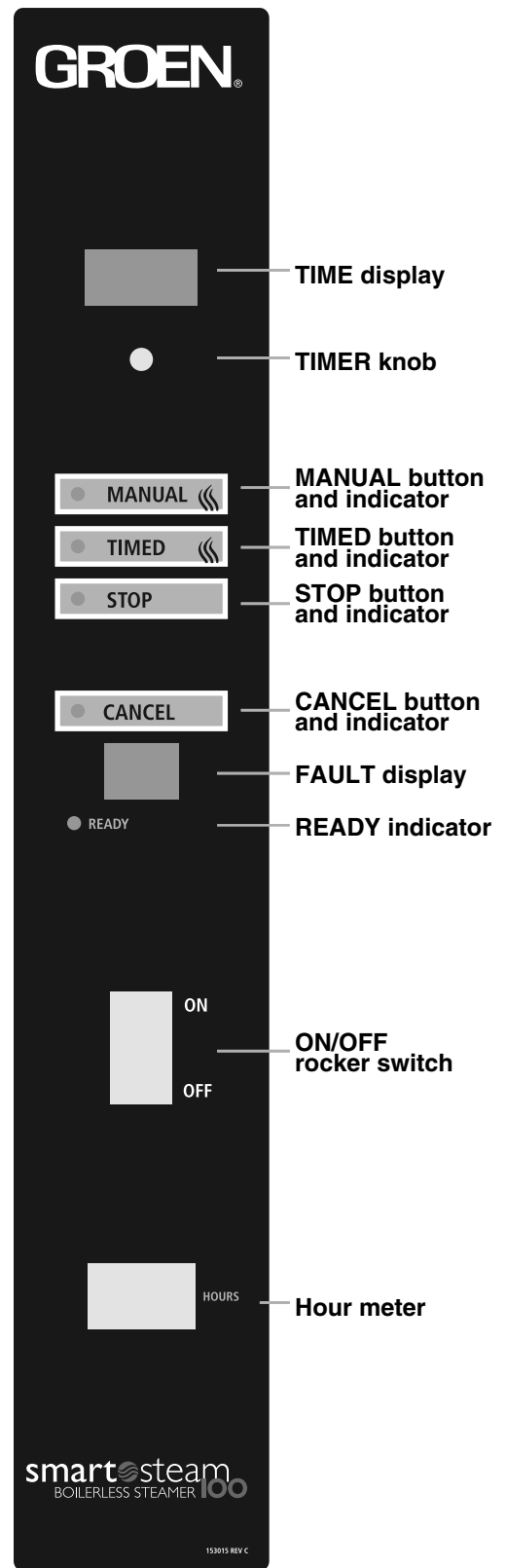

B. Operating Procedure

1. The unit will be ready in about 20 minutes.
2. Load food into pans in uniform layers. Pans should be filled to about the same levels, and should not be mounded.
3. Open the door and slide the pans onto the supports. If you will only be steaming one pan, put it in the middle position. Some foods will cause foam. When cooking foods that foam, such as shrimp, put an empty solid 2 ½ " deep pan in the bottom slot of the pan racks.
4. Close the door. When the READY indicator is lit, take one of the following steps:
 - ! If you want to steam the food for a certain length of time, push the TIMED button and set the desired time with the TIMER knob. The timer will automatically run the steamer for the set time and then go into STOP. A beeper will sound. Push CANCEL to stop beeping.
 - ! If you want to steam continuously, push MANUAL button. The unit will continue steaming until stopped.
 - ! Push STOP to stop producing steam.



WARNING
WHEN YOU OPEN THE DOOR, STAY AWAY FROM THE STEAM COMING OUT OF THE UNIT. THE STEAM CAN CAUSE BURNS.

5. To remove pans from cavity, open the door. Remove the pans from the steamer, using hot pads or oven mitts to protect your hands from the hot pans.
6. To shut off the unit, press the ON/OFF rocker switch to OFF. The steam generating reservoir will then fill with cold water and drain.

NOTE: If a large amount of shrimp is cooked in the SmartSteam100, foaming will occur because the steam lid actually gets so hot that the shrimp will cook on its surface and the shrimp proteins in the dripping will foam on the surface of the steam lid. * To avoid this, use a catch pan to catch shrimp drippings and proteins to prevent foaming when cooking a large amount of shrimp.

Cleaning

To keep your SmartSteam100 Boilerless Steamer in proper working condition, use the following procedure to clean the unit. This regular cleaning will reduce the effort required to clean the steam generator and cavity.

A. Suggested Supplies

1. Mild detergent
2. Stainless steel exterior cleaner Groen Spray DeGreaser (Part Number 140830WS)
3. Cloth or sponge
4. Brush with soft bristles
5. Spray bottle
6. Measuring cup
7. Nylon pad
8. Towels
9. Plastic disposable gloves
10. Funnel



B. Procedure

1. Exterior Cleaning
 - a. Prepare a warm solution of the mild detergent as instructed by the supplier. Wet a cloth with this solution and wring it out. Use the moist cloth to clean the outside of the unit. Do not allow freely running liquid to touch the controls, the control panel, any electrical part, or any louver on the rear panels.
 - b. To remove material which may be stuck to the unit, use a fiber brush or a plastic or rubber scraper with a detergent solution.
 - c. Stainless steel surfaces may be polished with a recognized stainless steel cleaner.
2. Interior Cleaning



Daily cleaning must be done in order to enhance the performance and prolong the life of your SmartSteam Boilerless Steamer.

WARNING
DISCONNECT THE POWER SUPPLY BEFORE CLEANING THE OUTSIDE OF THE STEAMER.

KEEP WATER AND CLEANING SOLUTIONS OUT OF CONTROLS AND ELECTRICAL COMPONENTS. NEVER HOSE OR STEAM CLEAN ANY PART OF THE UNIT.

AVOID CONTACT WITH ANY CLEANERS, DELIMING AGENT OR DEGREASER AS RECOMMENDED BY THE SUPPLIER. MANY ARE HARMFUL. READ THE WARNINGS AND FOLLOW THE DIRECTIONS!

EVEN WHEN THE UNIT HAS BEEN SHUT OFF, DON'T PUT HANDS OR TOOLS INTO THE COOKING CHAMBER UNTIL THE FAN HAS STOPPED TURNING.

DON'T OPERATE THE UNIT UNLESS THE REMOVABLE PARTITION HAS BEEN PUT BACK IN ITS PROPER LOCATION.

DON'T USE ANY CLEANING AGENT THAT CONTAINS ANY SULFAMIC AGENT OR ANY CHLORIDE, INCLUDING HYDROCHLORIC ACID (HCL). TO CHECK FOR CHLORIDE CONTENT SEE ANY MATERIAL SAFETY DATA SHEETS PROVIDED BY THE CLEANING AGENT MANUFACTURER.

IMPORTANT

DO NOT USE ANY METAL MATERIAL (SUCH AS METAL SPONGES) OR METAL IMPLEMENTS (SUCH AS A SPOON, SCRAPER OR WIRE BRUSH) THAT MIGHT SCRATCH ANY STAINLESS STEEL SURFACE. SCRATCHES MAKE THE SURFACE HARD TO CLEAN AND PROVIDE PLACES FOR BACTERIA TO GROW. DO NOT USE STEEL WOOL, WHICH MAY LEAVE PARTICLES EMBEDDED IN THE SURFACE, WHICH COULD EVENTUALLY CAUSE CORROSION AND PITTING.

WARNING! ALLOW THE STEAMER TO COOL COMPLETELY BEFORE CLEANING. HOT SURFACES CAN CAUSE SEVERE BURNS.

CLEANING STEPS:

STEP 1 - Press OFF switch to turn steamer OFF and open steamer door.

STEP 2 - CAUTION: allow the steamer to cool completely before cleaning.

STEP 3 - Remove steam lid by grasping the two tabs located on the lid front and sliding pan forward.

STEP 4 - Remove left pan rack by lifting rack up and pulling away from cavity wall.

STEP 5 - Remove right fan shroud and rack assembly by lifting rack up and pulling away from cavity wall.

STEP 6 - Clean steam lid, left pan rack and rack/shroud assembly to remove food soils. These three parts may be cleaned in a dishwasher.

STEP 7 - Use a mild detergent to wipe down the entire steamer cavity to remove food and scale particles. Carefully clean float probes if food residue or loose scale is present. A thin layer of tightly bound scale is normal and will not affect steamer performance. If scale is excessive, then refer to deliming instructions below.

STEP 8 - Remove drain strainer and clean thoroughly to remove any build-up of debris.

STEP 9 - Replace pan racks and steam lid. Steamer is now cleaned and ready to use.

FAILURE TO CLEAN THE STEAMER AS SPECIFIED COULD NEGATIVELY IMPACT THE PERFORMANCE OF THE STEAMER.

FLOAT PROBE ORIENTATION

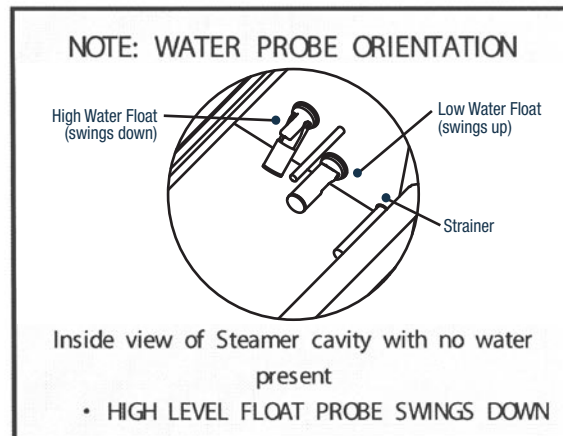

DELIMING INSTRUCTIONS:

- When using Groen Boilerless Water Filtration System use vinegar as a deliming agent.
- Groen approved delimer may be used to remove excessive scale build-up.

STEP 1 - After following all cleaning steps 1 through 7 listed above, turn steamer on and allow water to enter steamer cavity.

STEP 2 - Pour 1 cup of vinegar or delimer into steamer cavity and shut door.

STEP 3 - Set steamer timer to 30 minutes and allow steam cleaning to occur.

STEP 4 - After 30 minutes cleaning cycle is complete, turn steamer OFF and allow to cool completely.

STEP 5 - Open steamer door and wipe down the entire steamer cavity to remove loosened scale particles. Carefully clean float probes if loose scale is present.

STEP 6 - Replace pan racks and steam lid. Steamer is now cleaned and ready to use.

Maintenance

The SmartSteam100 Boilerless Steamer is designed for minimum maintenance and no user adjustments should be necessary. Certain parts may need replacement after prolonged use. If there is a need for service, only Groen Authorized Service Agents should perform the work.

If steam or condensate is seen leaking from around the door, take the following steps:

1. Check the door gasket. Replace it if it is cracked or split.
2. Inspect the cooking chamber drain to be sure it is not blocked.
3. Adjust the door latch pin to allow for changes that might occur as the gasket ages.
 - a. Loosen the lock nut at the base of the latch pin, then turn the latch pin 1/4 turn clockwise, and tighten the lock nut.
 - b. After adjustment, run the unit to test for further steam leakage.
 - c. If there is still leakage, repeat the adjustment
 - d. Continue adjusting the pin clockwise until the door fits tightly enough to prevent leakage. The hinge may also be adjusted.

Troubleshooting

Your Groen SmartSteam Boilerless Steamer is designed to operate smoothly and efficiently if properly maintained. However, the following is a list of checks to make in the event of a problem. Wiring diagrams are furnished inside the service panel. If an item on the check list is marked with (*), it means that the work should be done by a Groen Authorized Service Agent.

SYMPTOM	WHO	WHAT TO CHECK
1. Fault Display 1 or 2	User	a. Clean floats in unit / Check float probe orientation b. Be sure water supply is adequate to run steamer(s) during normal operation.
2. No power.	User	a. Check wall circuit breaker. b. Disconnect power, then check fuses on inside of steamer. * c. Call service technician.
3. Unit overfills with water at start up.	User	a. Clean floats in unit / Check float probe orientation. b. Clean drain strainer. c. Call service technician.
4. Steamer does not fill with water.	User	a. Is the ON switch depressed? b. Is the water supply connected? c. Is the water turned on? d. Is the water supply hose kinked or obstructed? e. Check for low water pressure (less than 30 PSI) or low water flow (less than 1.5 gpm). f. Is the screen at the water connection clogged?
5. "Door" Shown in Time Display Window	User	a. Is the steamer door securely closed?
6. No steam.	User	a. Is the ON switch depressed? b. Is the water supply connected? c. Is the water turned on? d. Is steamer door completely closed?
7. Fault Display 7	User	a. The component cooling fan may not be operating. The display may come on for several minutes during normal operation. If it stays on for more than 30 minutes, call service technician. Unit may be used for cooking, while waiting for service.

8. Any unusual operation.	User	a. Press OFF switch to turn steamer off. Momentarily turn circuit breaker off and then on or unplug from power. Turn unit back on.
9. Door pops open.	User	a. Ensure drain and vent are not plugged. No more than two units should be attached to a single drain line. b. Check door pin adjustment per above. c. Call service technician.
10. Fault Display 6	User	a. Wait 30 minutes for unit to cool down. b. Call service technician.