

OPERATOR MANUAL

IMPORTANT INFORMATION, KEEP FOR OPERATOR

This manual provides information for:

OM-AH/1E Domestic **STEAM JACKETED KETTLE WITH STANDARD ELECTRONIC IGNITION**

- MODEL: AH/1E
- Self-Contained
 - Gas Heated
 - Floor Mounted
 - Stationary



THIS MANUAL MUST BE RETAINED FOR FUTURE REFERENCE. READ, UNDERSTAND AND FOLLOW THE INSTRUCTIONS AND WARNINGS CONTAINED IN THIS MANUAL.

FOR YOUR SAFETY

Do not store or use gasoline or other flammable vapors and liquids in the vicinity of this or any other appliance.

POST IN A PROMINENT LOCATION

Instructions to be followed in the event user smells gas. This information shall be obtained by consulting your local gas supplier. As a minimum, turn off the gas and call your gas company and your authorized service agent. Evacuate all personnel from the area.

WARNING

Improper installation, adjustment, alteration, service or maintenance can cause property damage, injury or death. Read the installation, operating and maintenance instructions thoroughly before installing or servicing this equipment.

NOTIFY CARRIER OF DAMAGE AT ONCE

It is the responsibility of the consignee to inspect the container upon receipt of same and to determine the possibility of any damage, including concealed damage. Unified Brands suggests that if you are suspicious of damage to make a notation on the delivery receipt. It will be the responsibility of the consignee to file a claim with the carrier. We recommend that you do so at once.

Manufacture Service/Questions 888-994-7636.

Information contained in this document is known to be current and accurate at the time of printing/creation. Unified Brands recommends referencing our product line websites, unifiedbrands.net, for the most updated product information and specifications.

PART NUMBER 121051, REV. F (5/08)

G GROEN®



1055 Mendell Davis Drive
Jackson, MS 39272
888-994-7636, fax 888-864-7636
groen.com

IMPORTANT — READ FIRST — IMPORTANT

- WARNING:** IMPROPER INSTALLATION, ADJUSTMENT, ALTERATION, SERVICE OR MAINTENANCE CAN CAUSE PROPERTY DAMAGE, INJURY OR DEATH. READ THE INSTALLATION, OPERATING AND MAINTENANCE INSTRUCTIONS THOROUGHLY BEFORE INSTALLING OR SERVICING THIS EQUIPMENT.
- WARNING:** THE UNIT MUST BE INSTALLED BY PERSONNEL QUALIFIED TO WORK WITH GAS AND ELECTRICITY.
- WARNING:** UNIT MUST BE INSTALLED IN ACCORDANCE WITH ALL APPLICABLE CODES.
- CAUTION:** TO AVOID DAMAGING PARTS OF THE BURNER SYSTEM UNDERNEATH THE KETTLE, LIFT THE UNIT ONLY BY THE RING BENEATH THE OUTER PORTION OF THE BODY.
- WARNING:** DO NOT ATTACH THE UNIT TO A TYPE “B” VENT. IT COULD CAUSE FIRE OR PROPERTY DAMAGE.
- WARNING:** DO NOT CONNECT ANY PIPING TO THE SAFETY VALVE. IT MUST BE FREE TO VENT STEAM AS NEEDED. TO AVOID BURNS FROM THE VENTED STEAM THE VALVE DISCHARGE SHOULD POINT DOWN. IMPROPER INSTALLATION WILL VOID WARRANTY.
- WARNING:** FAILURE TO PERIODICALLY CHECK SAFETY VALVE OPERATION COULD RESULT IN PERSONAL INJURY AND/OR DAMAGE TO EQUIPMENT.
- WARNING:** WHEN TESTING, AVOID EXPOSURE TO THE STEAM BLOWING OUT OF THE SAFETY VALVE. DIRECT CONTACT COULD RESULT IN SEVERE BURNS.
- DANGER:** ELECTRICALLY GROUND THE UNIT AT THE TERMINAL PROVIDED. FAILURE TO GROUND THE UNIT COULD RESULT IN ELECTROCUTION AND DEATH.
- CAUTION:** BE SURE ALL OPERATORS READ, UNDERSTAND AND FOLLOW THE OPERATING INSTRUCTIONS, CAUTIONS AND SAFETY INSTRUCTIONS CONTAINED IN THIS MANUAL.
- CAUTION:** DO NOT OVERFILL THE KETTLE WHEN COOKING, HOLDING OR CLEANING. KEEP LIQUIDS A MINIMUM OF 2-3” (5-8 CM) BELOW THE KETTLE BODY RIM TO ALLOW CLEARANCE FOR STIRRING, BOILING AND SAFE TRANSFER OF PRODUCT.
- CAUTION:** KEEP FLOORS IN FRONT OF KETTLE WORK AREA CLEAN AND DRY. IF SPILLS OCCUR, CLEAN IMMEDIATELY TO AVOID SLIPS OR FALLS.
- WARNING:** KEEP WATER AND SOLUTIONS OUT OF CONTROLS AND BURNERS. NEVER SPRAY OR HOSE DOWN THE CONTROL CONSOLE, ELECTRICAL CONNECTIONS, ETC.
- CAUTION:** MOST CLEANERS ARE HARMFUL TO THE SKIN, EYES, MUCOUS MEMBRANES AND CLOTHING. TAKE PRECAUTIONS: WEAR RUBBER GLOVES, GOGGLES OR FACE SHIELD AND PROTECTIVE CLOTHING. CAREFULLY READ WARNINGS AND FOLLOW DIRECTIONS ON CLEANER LABELS .
- NOTICE:** NEVER LEAVE A SANITIZER IN CONTACT WITH STAINLESS STEEL SURFACES LONGER THAN 10 MINUTES. LONGER CONTACT CAN CAUSE CORROSION AND PITTING.
- WARNING:** TO AVOID INJURY, READ AND FOLLOW ALL PRECAUTIONS STATED ON THE LABEL OF THE WATER TREATMENT COMPOUND.
- WARNING:** BEFORE REPLACING ANY PARTS, DISCONNECT THE UNIT FROM THE ELECTRIC POWER SUPPLY AND CLOSE THE MAIN GAS VALVE. ALLOW FIVE MINUTES FOR GAS TO VENT.
- CAUTION:** USE OF ANY REPLACEMENT PARTS OTHER THAN THOSE SUPPLIED BY GROEN OR AUTHORIZED DISTRIBUTORS CAN CAUSE INJURY TO THE OPERATOR AND DAMAGE TO THE EQUIPMENT AND WILL VOID ALL WARRANTIES.
- WARNING:** KEEP AREA AROUND KETTLE FREE AND CLEAR OF ALL COMBUSTIBLE MATERIALS. FAILURE TO DO SO COULD RESULT IN FIRE OR PROPERTY DAMAGE.
- CAUTION:** HEATING AN EMPTY KETTLE MAY CAUSE THE RELEASE OF STEAM FROM THE SAFETY VALVE.
- CAUTION:** UNIT WEIGHS 470 TO 1120 LB. (212 TO 509 KG). FOR SAFE HANDLING, INSTALLER SHOULD OBTAIN HELP AS NEEDED, OR EMPLOY APPROPRIATE MATERIALS HANDLING EQUIPMENT (SUCH AS A FORKLIFT, DOLLY, OR PALLET JACK) TO REMOVE THE UNIT FROM THE SKID AND MOVE IT TO THE PLACE OF INSTALLATION.
- WARNING:** THIS UNIT IS DESIGNED FOR COMMERCIAL USE. NEVER USE HOME OR RESIDENTIAL GRADE GAS CONNECTIONS. THEY DO NOT MEET COMMERCIAL GAS CODES AND COULD BE HAZARDOUS.
- IMPORTANT:** SERVICE PERFORMED BY OTHER THAN FACTORY AUTHORIZED PERSONNEL WILL VOID ALL WARRANTIES.

Table of Contents

INSTALLER AND OPERATOR WARNINGS	2
REFERENCES	3
EQUIPMENT DESCRIPTION	4
INSPECTION & UNPACKING	5
INSTALLATION & START-UP	6
OPERATION	8
SEQUENCE OF OPERATION	10
CLEANING	11
MAINTENANCE	12
TROUBLESHOOTING	14
PARTS LISTS.	16
ELECTRICAL SCHEMATIC.	22
SERVICE LOG	23
WARRANTY	24

References

CSA America Inc.
8501 East Pleasant Valley Road
Cleveland, Ohio 44131
ANSI Z83.11

NSF INTERNATIONAL
789 N. Dixboro Rd.
P.O. Box 130140
Ann Arbor, Michigan 48113-0140
NSF / ANSI 4

NATIONAL FIRE PROTECTION ASSOCIATION
60 Battery March Park
Quincy, Massachusetts 02269

NFPA/54 - Installation Gas Appliances & Piping
NFPA/70 - The National Electrical Code

AMERICAN NAT'L STANDARDS INST., INC.
1430 Broadway
New York, New York 10018

Z223.1-1984 - National Fuel Gas Code
Z21.30 - Installation of Gas Appliances & Piping

Equipment Description

Groen AH/1E steam kettles are stainless steel, floor mounted kettles with a self-contained steam source heated by gas. A closed steam jacket covers the lower $\frac{2}{3}$ of the kettle. Heat from the gas burner boils water in the jacket to produce steam under pressure. To ignite the burners, Model AH/1 uses electronic spark ignition.

The kettles are stationary (non-tilting). Liquids can be removed through the tangent draw-off valve.

Exposed surfaces are stainless steel. Insulated sheathing protects the kettle body, and a housing encloses the controls. Three tubular legs support the unit. Bullet feet adjust to level the kettle.

A one piece dome cover is hinged to the kettle on the AH/1E-20. Covers for 40, 60, 80, and 100 gallon kettles are supplied with counterbalancing spring actuators to hold the covers in the fully open or closed position.

Controls provided include the ON/OFF switch, to control electric power for the unit, and the thermostat, to set the cooking temperature. The automatic controls and a brief description of each are as follows.

- a. Gas pressure regulator: Protects the unit from high pressure in the gas supply line
- b. Automatic gas valves: Allow gas into the burners as needed
- c. Pressure limit switch: Turns off the burner when jacket pressure reaches 27 PSI. Lights the burner when pressure drops to 22 PSI.
- d. Safety valve: Lets steam out of the jacket if the steam pressure exceeds 30 PSI.
- e. Low-water cutoff: Turns off the burner if the water level in the jacket gets too low for safe operation

Instruments also are provided to show what is happening inside the unit. These are:

- a. Water level sight glass: Indicates whether there is enough water in the steam jacket.
- b. Pressure/vacuum gauge: Shows steam pressure, and whether too much air has entered the jacket.
- c. Heating indicator light: Indicates that the kettle is being heated.
- d. Power on indicator light: Glows when the unit is turned on.
- e. Low water indicator light: Lights to show that jacket water needs to be replenished.

The kettle body is welded into one piece and has a rim reinforced by a rectangular bar. The interior and exterior of the kettle is polished to a 180 emery grit finish. The unit is ASME shop inspected and registered with the National Board for working pressures up to 30 PSI.

The standard 2 inch tangent draw-off is a 316 stainless steel, compression disc valve. A removable strainer with $\frac{1}{4}$ inch holes keeps pieces of product from entering the draw-off during cooking.

The jacket is filled at the factory with water containing rust inhibitors. The kettle can operate at steam pressures up to 30 PSI, which provide temperatures of 150°F (65°C) to approximately 270°F (135°C). This range allows warming, simmering, boiling, or braising.

For AH/1 kettles, options include:

- a. Larger (3 inch) draw-off
- b. Solid disc strainer or strainer with $\frac{1}{8}$ inch perforations
- c. Water fill faucets
- d. Automatic, metered water filler (Gallon Master)
- e. Basket Inserts (Model TRI-BC)
- f. Kettle brush kit
- g. Gallon etch marks
- h. Flanged feet

KETTLE CHARACTERISTICS

Kettle	Ignition	Firing Rate, BTU/hour	
		Natural Gas	Propane Gas
AH/1E-20	Spark	85,000	85,000
AH/1E-40	Spark	100,000	85,000
AH/1E-60	Spark	145,000	145,000
AH/1E-80	Spark	145,000	145,000
AH/1E-100	Spark	145,000	145,000

KETTLE CHARACTERISTICS

Model	Kettle Capacity Gallons (Liters)	Jacket Capacity Gallons (Liters)	Kettle Diameter Inches (Millimeters)	Kettle Depth Inches (Millimeters)	Overall Width Inches (Millimeters)	Front-to-Back, Inches (Millimeters)	Rim Height Inches (Millimeters)
AH/1E-20	20 (75)	4.5 (17)	20 (508)	18 (457)	36.75 (933.5)	39 (990.6)	40 (1016)
AH/1E-40	40 (150)	7 (26.5)	26 (660)	22(559)	38.25 (971.55)	45 (1143)	42 (1066.8)
AH/1E-60	60 (225)	9.5 (36)	30 (762)	25 (635)	41 (1041.4)	49 (1244.6)	49 (1244.6)
AH/1E-80	80 (300)	11.5 (43.5)	32 (813)	29 (737)	42.5 (1079.4)	51 (1295.4)	55.5 (1409.7)
AH/1E-100	100 (375)	11.5 (43.5)	32 (813)	35 (889)	42.5 (1079.4)	51 (1295.4)	61.5 (1562.1)

Inspection & Unpacking

WARNING

THIS UNIT MUST BE INSTALLED BY PERSONNEL WHO ARE QUALIFIED TO WORK WITH ELECTRICITY AND PLUMBING. IMPROPER INSTALLATION CAN CAUSE INJURY TO PERSONNEL AND/OR DAMAGE TO THE EQUIPMENT. THE UNIT MUST BE INSTALLED IN ACCORDANCE WITH APPLICABLE CODES.

The unit arrives completely assembled, except for the TDO valve and flue gas converter, which are usually packed separately and shipped inside the kettle.. The unit is strapped on a skid in a heavy box. Inspect the box carefully for damage. Open the container and check the unit for hidden damage. Report shipping damage or shipment errors to the delivery agent.

Write down the model number, serial number, and installation date for your unit at the top of the Maintenance and Service Log at the back of this manual. Keep the manual with the unit.

To remove the kettle from the box, cut any straps from around the box. Detach the box sides from the skid. Pull the box up off the unit, taking care to avoid damage or injury from any staples left in the box walls. When installation is to begin, cut the straps holding the kettle to the skid, and lift the kettle straight up off the skid. Examine the packing materials to make sure no loose parts are discarded with the materials.

CAUTION

SHIPPING STRAPS ARE UNDER TENSION AND CAN SNAP BACK WHEN CUT. TAKE CARE TO AVOID PERSONAL INJURY OR DAMAGE TO THE UNIT BY STAPLES LEFT IN THE WALLS OF THE CARTON.

UNIT WEIGHS FROM 468 LBS. (212 KG) TO 1120 LBS. (508 KG). FOR SAFE HANDLING, INSTALLER SHOULD OBTAIN HELP AS NEEDED AND USE MATERIAL HANDLING EQUIPMENT TO REMOVE THE UNIT FROM THE SKID AND MOVE IT TO ITS PLACE OF INSTALLATION.

Once the kettle is unpacked, the tangent draw-off valve is easily attached, as shown below. The large nut which attaches the valve to the kettle should be **hand tightened** only.



Assemble and attach the tangent draw-off valve after the kettle is unpacked.

WARNING

THIS PRODUCT MUST BE INSTALLED BY A LICENSED PLUMBER OR GAS FITTER WHEN INSTALLED WITHIN THE COMMON WEALTH OF MASSACHUSETTS. IMPROPER INSTALLATION CAN CAUSE INJURY TO PERSONNEL AND/OR DAMAGE TO THE EQUIPMENT.

THIS UNIT IS FOR COMMERCIAL USE. NEVER USE HOME OR RESIDENTIAL GRADE GAS CONNECTIONS. THEY DO NOT MEET GAS CODES AND COULD BE HAZARDOUS.

Installation and Initial Start-Up

A. Installation

The unit should be installed in a ventilated room for efficient performance. Items which may obstruct or restrict the flow of air for combustion and ventilation must be removed. The area directly around the appliance must be cleared of all combustible materials.

1. Installation requires connection with gas and electrical services. See items 8 to 14 for details.
2. To protect the unit from damage, leave it on the shipping pallet until the time of installation. When installation is to begin, cut the straps holding the kettle, and hoist the kettle straight up off the skid.

NOTICE

To avoid damaging parts of the burner system underneath the kettle, LIFT THE UNIT ONLY BY THE RING beneath the outer portion of the body.

3. Install the unit with a minimum clearance to combustible and non-combustible construction of six inches at the sides and six inches between the draft diverter and the wall. Also leave enough room for cleaning, maintenance, and service.

Fig. 1

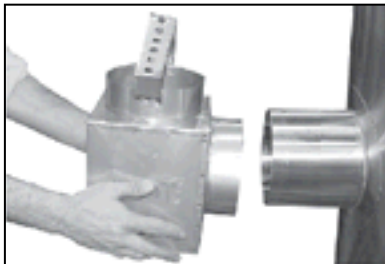
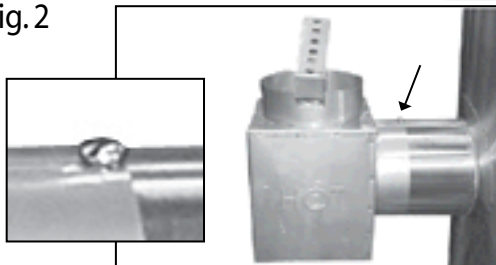

Fig. 2



4. The draft diverter shipped with the kettle is the correct height and shape to give maximum performance. Install the draft diverter as shown on Figures 1 and 2 above. Securely fasten the screw to attach draft directly. Do not change the diverter in any way.

WARNING

DO NOT ATTACH THE UNIT TO A TYPE "B" VENT. FAILURE COULD RESULT IN FIRE OR PROPERTY DAMAGE.

Install the unit under a ventilation hood, or vent the flue directly to a masonry chimney. Put a hood at least several inches above the upper end of the draft diverter. Do **not** rest hood supports on the diverter. Installation of a ventilating hood should comply with local codes and/or ANSI/NFPA-96 Latest Edition. Also, local codes may require that the kettle be electrically interlocked to shut off the gas supply and prevent the operation of the unit if the exhaust fan is not operating or if the fire suppression system is activated. Failure to follow these instructions can cause bodily injury and/or property damage.

5. To level the unit, adjust leg length by turning the bullet feet
6. Make sure the water level is correct in the jacket, by confirming that the level is between the marks on the gauge glass. If the water level is low, follow the instructions under "Jacket Filling" in the "Maintenance" Section of this manual.

CAUTION

DO NOT CONNECT ANY PIPING TO THE PRESSURE RELIEF SAFETY VALVE. IT MUST BE FREE TO VENT STEAM AS NEEDED. ELBOW SHOULD POINT DOWN TOWARD FLOOR. IMPROPER INSTALLATION WILL VOID WARRANTY!

7. To protect personnel from steam coming out of the safety valve, the open end of the elbow at the outlet must be directed down. If it is not, turn the elbow to the correct position.

DANGER ELECTRICALLY GROUND THE UNIT AT THE TERMINAL PROVIDED. FAILURE TO GROUND UNIT COULD RESULT IN ELECTROCUTION AND DEATH.

8. Provide 115 VAC, 60 HZ, 1 PH, 15 AMP electrical service for standard unit. Unit may be equipped for alternate electrical service of 208 VAC or 240 VAC, as ordered. Use 1/2 inch waterproof conduit and waterproof connections. Observe local codes and/or The National Electrical Code in accordance with ANSI/NFPA 70 - latest edition. **AN ELECTRICAL GROUND IS REQUIRED.** The electrical schematic is located on the inside of the service panel.

In Canada, provide electrical service in accordance with the Canadian Electrical Code, CSA C22.1 Part 1 and/or local codes.

9. The internal gas lines of the unit were cleaned and closed off with a gas cock before the unit was shipped from the factory. Free all external gas lines of lint, dirt, metal chips, sealant, grease, oil, and other contaminants, before you connect the lines to the kettle.
10. Connect the gas cock of the kettle to the gas service main with 3/4 inch IPS line or approved equivalent
11. Installation must conform with local codes, or in the absence of local codes, with the National Fuel Gas Code, ANSI Z 223.1-1988 (or latest edition). The unit should be installed in an adequately ventilated room with a provision for adequate air supply. The best ventilation will utilize a vent hood and exhaust fan with no direct connection between the vent duct and the flue. Do NOT obstruct the flue or vent duct after installation.
In Canada, the installation must conform to the CAN/CGA B149 Installation Codes for Gas Burning Appliances and Equipment and/or local codes.
12. Adequate space for proper service and operation is required. Do **NOT** block any air intake spacings to the combustion chamber or obstruct the air flow by piling or stacking anything near the kettle.
13. After the kettle has been connected to the gas supply, all gas line joints must be checked for leaks. **DO NOT USE A FLAME TO CHECK FOR LEAKS.** A thick soap solution or other suitable leak detector should be employed.
14. For a unit on casters, complete connection to the gas supply with connectors that comply with the standard for connectors for moveable gas appliances, ANSI Z21.69 — latest edition. Restrain movement of the unit by attaching a cable or chain to the eyelet (provided at the back of the frame) and anchoring the cable or chain to the wall or floor. Make the length and location of the cable such that the unit cannot pull on the gas connection while the cable is connected.
15. The appliance and its individual shutoff valve must be **disconnected** from the gas supply piping system during any pressure testing of that system at test pressures **in excess of** 1/2 PSIG (3.48 kPa). The appliance must be **isolated** from the gas supply

piping system by closing its individual manual shutoff valve during any pressure testing of the gas supply piping system at test pressures **equal to or less than** 1/2 PSIG (3.48 kPa)

16. Check the following points to confirm that your AH kettle has been installed properly. **Any mechanical, electrical, or gas type change must be approved by the Groen Food Service Engineering Department.**
 - a. Enough room between the kettle and nearby objects for cleaning and service.
 - b. Minimum clearance of 6 inches from sides and 6 inches from draft diverter.
 - c. Unit vented to a hood or chimney. (Not attached to a vent.
 - d. Kettle level.
 - e. Correct amount of water in the jacket.
 - f. Pressure relief safety valve outlet pointed down.
 - g. Connected with a waterproof, 115 volt, 15 amp supply of electric power in accordance with electrical codes.
 - h. Gas lines cleaned before connection.
 - i. Gas connected with 3/4 inch pipe or equivalent
 - j. Gas line joints checked for leaks.
 - k. No obstruction to air supply or venting.

B. Initial Start-Up

After the kettle has been installed, the installer should test to ensure that it is operating correctly.

1. Remove literature and packing materials from inside and outside of the unit.
2. Install the TDO valve.
3. Put a small amount of water into the kettle.
4. Verify that kettle water level is normal and that kettle is holding vacuum in jacket. Correct if not.
5. Make sure the supplies of gas and electric power are on.
6. Follow the *Start Kettle Heating* instructions in the Operation section of this manual. Begin heating the water at the highest thermostat setting. The indicator light should come on and heating should continue until the water boils.
7. To turn off the unit, follow "To Stop Kettle Heating" in "Operating Instructions," below.

If the kettle functions as described, it is ready for use. If the unit does not operate as designed, contact authorized Groen Service Agent.

Operation

WARNING
ANY POTENTIAL USER OF THE EQUIPMENT MUST BE TRAINED IN SAFE AND CORRECT OPERATING PROCEDURES

A. Controls

Operator controls for the AH/1 kettle are:

1. Manual gas valve which controls the supply of gas from the main line to the unit.
2. On-Off (toggle) switch. This switch turns the control circuit power supply on or off.
3. Thermostat dial, which turns the thermostat on or off, and sets the kettle operating temperature.
4. Indicator Lights to alert operator of unit conditions:
 - a. Power On Indicator - shows that the unit is turned on
 - b. Heat Indicator - indicates that main gas is on to produce steam in the kettle jacket.
 - c. Low Water indicator - shows that jacket water is low
 - d. Unit gas pressure regulator adjustment - located behind the access door in the kettle skirt.
- c. DO NOT attempt to light any burner with a flame.
- d. Open main supply gas valve (handle in line with the pipe).
- e. Turn the toggle switch to ON. For 90 seconds, or until it succeeds, the electronic ignition control will attempt to light the pilot.
- f. Once the pilot is lit, turn the thermostat to the desired setting.
- g. If the pilot does not light, turn it off and wait five minutes. At that time follow the instructions for starting once again.
- h. If the unit repeatedly fails to light, contact an authorized Groen Service Agency for assistance.

B. Operating Instructions

WARNING
KEEP AREA AROUND KETTLE FREE AND CLEAR OF ALL COMBUSTIBLE MATERIALS

DO NOT ATTEMPT TO LIGHT ANY BURNER WITH A FLAME.

CAUTION
HEATING AN EMPTY KETTLE MAY CAUSE THE RELEASE OF STEAM FROM THE SAFETY VALVE.

1. To Start Kettle

- a. CHECK THE WATER LEVEL IN THE JACKET EVERY DAY. The level should be at the middle of the sight glass. If the level is low, see *Jacket Filling* in the Maintenance section of this manual
- b. Check the pressure/vacuum gauge. If the gauge does not show 20 to 30 inches of vacuum (i.e. a reading of 20 to 30 below zero), see *Jacket Vacuum* in the Maintenance section of this manual.



Hinged Cover for smaller models shown.



2. To Stop Kettle Heating

- a. Turn the thermostat dial to OFF.
- b. Turn the toggle switch OFF.
- c. For a prolonged shut-down:
 1. Follow the procedure above.
 2. Turn the manual gas valve OFF (handle at right angle to gas line).
 3. Disconnect the unit's electrical power.

3. To Relight Kettle

- a. Close main gas supply valve.
- b. Set on-off switch to OFF.
- c. Set thermostat to OFF.
- d. Wait five minutes, then proceed as directed under *To Start Kettle*.

4. If Electric Power Fails do not attempt to operate the unit. When power is restored, proceed as directed in *To Start Kettle*.



WARNING
 AVOID ALL DIRECT CONTACT WITH HOT FOOD OR WATER IN THE KETTLE. DIRECT CONTACT COULD RESULT IN SEVERE BURNS.

TAKE CARE TO AVOID CONTACT WITH HOT KETTLE BODY OR HOT PRODUCT, WHEN ADDING INGREDIENTS, STIRRING OR TRANSFERRING PRODUCT TO ANOTHER CONTAINER.

CAUTION
 DO NOT OVERFILL THE KETTLE WHEN COOKING, HOLDING OR CLEANING. KEEP LIQUIDS 2-3" (5-8 cm) BELOW THE KETTLE RIM TO ALLOW CLEARANCE FOR STIRRING, BOILING PRODUCT AND SAFE TRANSFER.

5. Basket Insert

- a. An optional kettle basket insert set (Tri-BC) will assist in cooking water-boiled products including eggs, potatoes, vegetables, shell fish, pasta and rice. The nylon mesh liners must be used when cooking product smaller than the mesh size of the basket, which is approximately 1/4" (6 mm). This includes rice and small pasta shapes.
- b. Tips for Use
 - 1) Allow for water displacement by the baskets and product to be cooked. This may mean only filling the kettle half full of water. Test the basket and product displacement with the kettle OFF, and with cold water in the kettle.
 - 2) Load baskets on a level, stable work surface.

- 3) Lift the loaded baskets with both hands. Get help from another person, if the basket is too heavy for safe handling.
- 4) Slowly lower product into the kettle.
- 5) When removing baskets with cooked product, lift basket straight up, ensuring bottom of basket clears the rim and pouring lip of the kettle. Wear protective oven mitts and protective apron.
- 6) Allow hot water to fully drain from product, before moving basket away from the kettle.
- 7) If basket is too heavy for individual to lift and safely move, get help from another person. Remove product immediately from basket into another container, being sure to avoid contact with hot product and hot basket **or**.
- 8) Place basket with food on stable, flat surface, setting it inside a solid steamer or bake pan, to catch any remaining hot water draining from product.

CAUTION DO NOT OVERFILL THE KETTLE WHEN COOKING, HOLDING OR CLEANING. KEEP LIQUIDS A MINIMUM OF 2-3" (5-8 cm) BELOW THE RIM TO ALLOW FOR STIRRING, BOILING AND SAFE PRODUCT TRANSFER.

Sequence of Operation

The following "action-reaction" outline is provided to help understand how the AH kettle works.

1. When the power switch is turned on, it starts the spark igniter and opens the automatic valve for the pilot burner. The spark ignites a pilot flame, which heats the sensor. The sensor then sends a signal to turn off the spark. The flame thereafter acts as a standing pilot until the power is turned off.
2. If the pilot flame is not sensed within 90 seconds after spark begins, a timer shuts down the entire operation. To attempt a second trial for ignition, turn off the power switch. Check the gas supply valves and wait five minutes before trying again by switching power on. If you cannot establish a pilot flame in four tries, close all valves, turn off the power, and contact an authorized Groen Service Agency.
3. When the operator sets a temperature on the thermostat, it causes the automatic valve to admit gas to the main burner, where it is ignited by the pilot flame. When the kettle reaches the set temperature, the thermostat switch opens. This stops the signal to the gas control valve and shuts off gas to the main burner. The pilot flame stays lit.
4. When the kettle cools below the set temperature, the thermostat switch closes and starts another cycle. On and off cycling continues and maintains the kettle at the desired temperature. This action is indicated by the Heat indicator light.

The kettle has the following safety features in addition to the 90-second ignition timer:

1. Low water cutoff relay that will shut off gas supplies to all burners until the jacket water level is corrected.
2. High limit pressure switch, set to open at about 26 PSI and to shut down the burners until jacket pressure is decreased.
3. Pressure relief safety valve, which will release steam if jacket pressure exceeds 30 PSI.
4. Gas pressure regulator built into the gas control valve.

Cleaning

1. Suggested Cleaning Supplies

- a. A high quality detergent and sanitizer, or a combination cleaning-sanitizing agent.
- b. Kettle brushes.
- c. Groen Spray Degreaser (P/N 114801) or equivalent.
- d. Groen Delimer-Descaler (P/N 114800) or equivalent.
- e. A high quality stainless steel cleaner.

2. Precautions

Before any cleaning, shut off the kettle by turning the thermostat dial to "OFF" and the On/Off switch to Off .



WARNING
KEEP WATER AND SOLUTIONS OUT OF CONTROLS AND BURNERS. NEVER SPRAY OR HOSE THE CONTROL CONSOLE, ELECTRICAL CONNECTIONS, ETC.

3. Procedure

- a. Clean food contact surfaces as soon as possible after use, preferably while the kettle is still warm. If the unit is in continuous use, clean and sanitize inside and outside at least once every 24 hours.
- b. Scrape and flush out large amounts of food residues. Be careful not to scratch the kettle with metal implements.

CAUTION
NEVER LEAVE A SANITIZER IN CONTACT WITH STAINLESS STEEL SURFACES LONGER THAN 30 MINUTES. LONGER CONTACT CAN CAUSE CORROSION.

- c. Prepare a solution of the detergent/cleaning compound as instructed by the supplier. Clean the unit thoroughly. A cloth moistened with cleaning solution can be used to clean controls, housing, electrical conduit, etc.
- b. Rinse the kettle thoroughly with hot water. Then drain completely.

- c. Disassemble the tangent draw-off valve. Clean the draw-off port and each valve part with a brush.
- d. Rinse the kettle and draw-off valve parts thoroughly with hot water, then drain completely.



When attaching the draw-off valve, just hand-tighten the nut.

- e. When you reassemble the draw-off valve, **hand-tighten** the nut which holds it in place.



CAUTION
MOST CLEANERS ARE HARMFUL TO THE SKIN, EYES, MUCOUS MEMBRANES AND CLOTHING. PRECAUTIONS SHOULD BE TAKEN TO WEAR RUBBER GLOVES, GOGGLES OR FACE SHIELD AND PROTECTIVE CLOTHING. CAREFULLY READ THE WARNINGS AND FOLLOW LABEL DIRECTIONS.

- f. As part of the daily cleaning program, clean all inside and outside surfaces that may have been soiled. Remember to check such parts as the underside of the cover, control housing, etc.
- g. To remove materials stuck to the equipment, use a brush, sponge, cloth, plastic or rubber scraper, or plastic wool along with the



Use sponge, cloth or plastic brush to clean the kettle.

detergent solution. To make washing easier, let the detergent solution sit in the kettle and soak into the residue, or warm the detergent solution briefly. Do not use any metal material (like metal sponges) or metal (like a spoon, scraper, or wire brush) that might scratch the surface. Scratches make the surface hard to clean and provide places for bacteria to grow. Do **not** use steel wool, which may leave particles imbedded in the surface and cause eventual corrosion and pitting.

- h. The outside of the unit may be polished with a recognized stainless steel cleaner.
- i. When the equipment needs to be sanitized, use a sanitizing solution equivalent to one that supplies 200 parts per million chlorine. Obtain advice on the best sanitizing agent from your supplier of sanitizing products.

- j. Following the supplier's instructions, apply the sanitizing agent, after the unit has been cleaned and drained. Rinse off the sanitizer thoroughly.
- k. It is recommended that the unit be sanitized just before use.
- l. If there is difficulty removing mineral deposits or a film left by hard water or food residues, clean the kettle thoroughly. Then use a de-liming agent, such as Groen De-limer De-Scaler (Part Number 114800). Rinse and drain the unit thoroughly before further use.
- m. If especially difficult cleaning problems persist, contact your cleaning product supplier for assistance. The supplier has a trained technical staff with laboratory facilities to serve you.



Scrapers or steel wool can harm the kettle surface.

Maintenance

NOTICE: Contact Groen or an authorized Groen Service Representative when repairs are required.

A Service Log is provided at the rear of this manual. Each time service is performed on this Groen equipment, enter the date on which the work was done, and who did it. Keep this manual with the equipment.

1. Jacket Vacuum/Removing Air from Jacket

When the kettle is cold, a positive pressure/ vacuum gauge reading or a reading near zero indicates that there is air in the jacket. Air in the jacket acts as an insulator, and slows kettle heating.

To remove air:

- a. Start the unit. (Be sure there is water or product in the kettle when heating).
- b. When the pressure/vacuum gauge reaches a positive pressure reading of five PSI, release the trapped air and steam by pulling up the safety valve ring for about five seconds. Repeat this step three or four times. Then let the pull ring snap back into the closed position.
- c. If there is little discharge (mostly air), and the pressure gauge drops back to zero PSI, allow the pressure to build back to five PSI and repeat the procedure.

- d. Once steam has been vented from the jacket as described in b, remove the hot water from the kettle and replace it with cold. This will condense steam in the kettle jacket, and the pressure gauge should show a reading of 20 to 30 inches mercury (Hg) below zero. If it does not, or if the vacuum is leaking down, contact a Groen authorized service agency.



WARNING
AVOID ANY EXPOSURE TO THE STEAM BLOWING OUT OF THE SAFETY VALVE. SEVERE BURNS CAN RESULT ON EXPOSED SKIN.

FAILURE TO CHECK SAFETY VALVE OPERATION PERIODICALLY COULD RESULT IN PERSONAL INJURY AND/OR DAMAGE TO EQUIPMENT.

WHEN TESTING, AVOID ANY EXPOSURE TO THE STEAM BLOWING OUT OF THE SAFETY VALVE. DIRECT CONTACT COULD RESULT IN SEVERE BURNS.

2. Test Pressure Relief Safety Valve

Test the pressure relief safety valve at least twice each month. With the kettle operating at five psi (105 kPa), pull the test lever and let it snap back to its closed position. If there is little discharge (mostly air), and the pressure gauge drops back to zero PSI, allow the pressure to build back to five PSI and repeat the procedure. (**Tip:** Using a will screwdriver or other implement to pull the ring help you avoid contact with the steam.)

3. Jacket Filling

Every day, **before you turn on the unit**, make sure the water level is approximately in the center

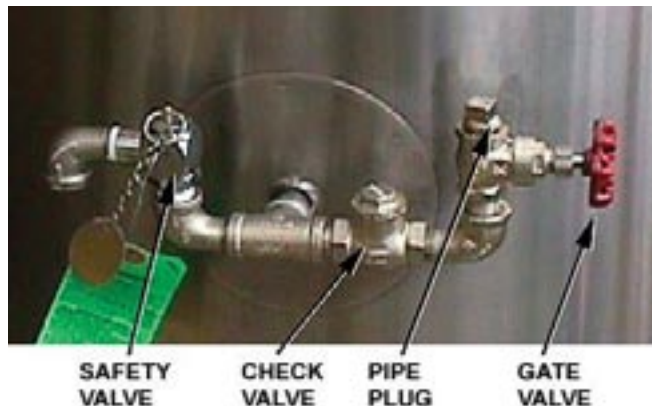

of the water gauge glass. The jacket was filled at the factory with the proper amount of treated water, and is air-tight, but over time steam may be vented and water lost.

From time to time, you may need to restore the

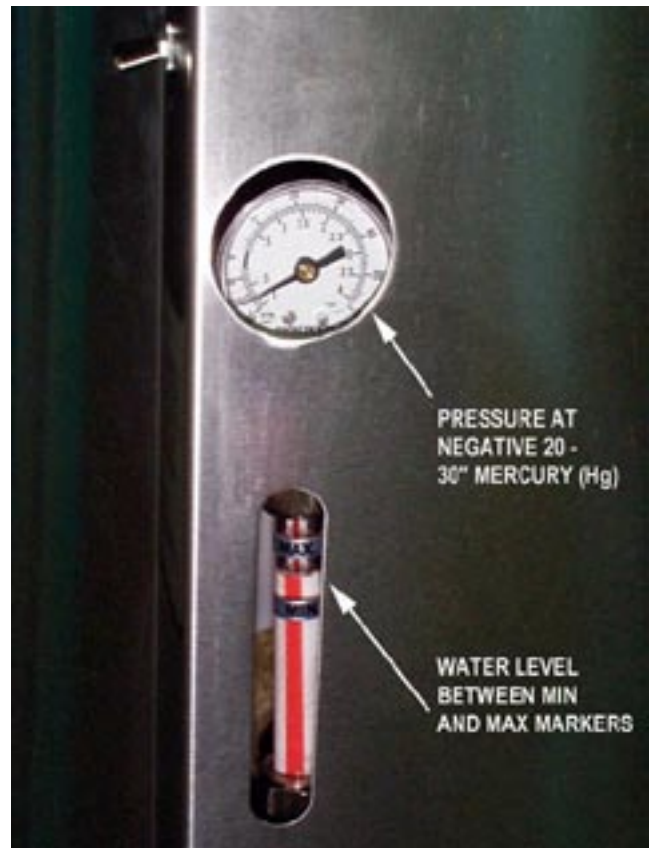

water to its proper level. to restore this water, either because it was lost as venting steam or by draining. If you are replacing water lost as steam, use distilled water. If you are replacing treated water that ran out of the jacket, prepare more treated water as directed in "Water Treatment Procedure," below.

Allow the kettle to cool completely. The procedure will be easier with the kettle under vacuum (pressure gauge reading below zero).

- Make sure the fill (gate) valve is closed, and remove the square head pipe plug with open-ended wrench or crescent wrench.
- Position a funnel in the opening and fill it with properly treated water.
- Slowly open the fill valve to allow water to be sucked into the jacket. Quickly close the valve to prevent air from entering.

- d. Check water level in the jacket to ensure that it is between minimum and maximum marks on glass.
- e. Close the valve and reinstall the square-head pipe plug.
- f. Reestablish the jacket vacuum as described in Paragraph 2, above, if the pressure gauge does not show a negative reading of 20 to 30 inches mercury (Hg).

Model	Kettle Capacity	Jacket Capacity
AH/1E-20	20 Gallons	4.5 Gallons
AH/1E-40	40 Gallons	7 Gallons
AH/1E-60	60 Gallons	9.5 Gallons
AH/1E-80	80 Gallons	11.5 Gallons
AH/1E-100	100 Gallons	11.5 Gallons

4. Water Treatment

WARNING
TO AVOID INJURY, READ AND FOLLOW ALL PRECAUTIONS STATED ON THE LABEL OF THE WATER TREATMENT COMPOUND.

- a. Fill a mixing container with the amount of water required. Use only distilled water.
- b. Following instructions apply to Groen Water Treatment Kit part number 110324.
 - i. Hang a strip of pH test paper on the rim of the container, with about 1 inch of the strip below the surface of the water.
 - ii. Stir the water continuously, while you slowly add water treatment compound until a color between indicating a pH of 10.5 and 11.5 is reached. (Shown on the pH test kit chart.) Judge the pH by frequently comparing the test strip with the color chart provided in the kit.
 - iii. Use a measuring cup to add the compound so that you may record the exact amount used.
 - iv. The amount may be used again, if the same water sources and compound are used in the future. However, it is best to check the pH each time treated water is prepared.

Troubleshooting

Your Groen kettle is designed to operate smoothly and efficiently if properly maintained. However, the following is a list of checks to make in the event of a problem. Wiring diagrams are furnished inside the service panel and in this manual. **If an item on the list is followed by , the work should be done by a qualified service representative.**

WARNING		
BEFORE REPLACING ANY PARTS, DISCONNECT THE UNIT FROM THE ELECTRIC POWER SUPPLY AND CLOSE THE MAIN GAS VALVE. ALLOW FIVE MINUTES FOR UNBURNED GAS TO VENT.		
CAUTION		
USEING REPLACEMENT PARTS OTHER THAN THOSE SUPPLIED BY GROEN OR THEIR AUTHORIZED DISTRIBUTOR CAN CAUSE OPERATOR INJURY AND EQUIPMENT DAMAGE AND WILL VOID ALL WARRANTIES.		
SYMPTOM	WHO	WHAT TO CHECK
		<small>indicates items which must be performed by an authorized technician.</small>
Kettle continues heating after it reaches desired temperature.	User	a. Thermostat dial setting.
	Auth Service Rep Only	b. Thermostat calibration. c. Thermostat operation. The thermostat should click when the dial is rotated to settings above and below the temperature of the kettle.
Kettle stops heating before it reaches the desired temperature.	User	a. Thermostat dial setting.
	Auth Service Rep Only	b. Thermostat calibration. c. Thermostat operation. The thermostat should click when the dial is rotated to settings above and below the temperature of the kettle.

SYMPTOM	WHO	WHAT TO CHECK ✗ indicates items which must be performed by an authorized technician.
Safety Valve pops open	User	a. For air in the jacket. See "Jacket Vacuum" in the Maintenance section. b. Thermostat dial setting.
	Auth Service Rep Only	c. For defective thermostat. The thermostat should click when the dial is rotated to settings above and below the temperature of the kettle. If defective, replace.✗ d. For defective safety valve. If the valve pops at pressures below 29 PSI, replace.✗
Burners will not light.	User	a. That the main gas supply valve is open. (handle is in line with the gas pipe). b. Gas supply to the building.
	Auth Service Rep Only	d. Thermostat operation. The thermostat should click when the dial is rotated to settings above and below the temperature of the kettle.✗
System does not produce a spark	Auth Service Rep Only	a. AC voltage between terminals on secondary side of transformer with unit power turned on. If it is not 24 Volt, replace the transformer ✗ b. That the high tension cable is firmly attached and in good condition. If cracked or brittle, replace.✗ c. Pilot burner ceramic insulator for crack or break.✗ d. Pilot spark gap. Regap.✗
Spark is present but the pilot will not light.	Auth Service Rep Only	a. That the pilot valve is securely connected to terminals.✗ b. For 24 VAC at terminals PV and PV/MV. If 24V is not present, replace the ignition control module.✗ b. That gas pressure is at least 3.5" W.C.(8.7818 μb).✗ c. For gas at the pilot. If it is not flowing: (1) Check the pilot gas line for kinks and obstructions.✗ (2) Clean orifice, if necessary.✗ (3) Check magnetic operator for pilot valve on gas valve. Repair or replace as necessary.✗ d. That the pilot spark gap is located in the pilot gas stream. If not, adjust or replace the pilot burner.✗ e. For drafts. Shield the pilot burner, if necessary.✗
Pilot lights, but main burner will not come on and spark does not stay on.	Auth Service Rep Only	a. For 24 V between terminals MV and PV/MV while pilot is burning. If 24V is not present, replace the ignition control module.✗ b. That gas pressure is at least 3.5" W.C.(8.7818 μb).✗ c. Electrical connections of the main valve to terminals, to assure that they are securely attached. Check magnetic operator for main valve on gas valve. Repair or replace as necessary.✗
Pilot lights, but main burner will not come on, the spark stays on.	Auth Service Rep Only	a. Check for bad burner ground. If necessary, repair with high temperature wire.✗ b. Pilot burner ceramic insulator for cracks.✗ c. That cable is not grounded out. If it is, correct the ground-out condition or replace cable.✗ d. For proper gas pressure.✗ e. Clean pilot assembly, or replace if necessary.✗ f. Tighten all mechanical and electrical connections.✗ g. If the pilot flame is weak, increase pilot orifice size.✗ h. Replace ignition control module.✗
Main burner comes on but will not stay on.	Auth Service Rep Only	a. Check burner ground for bad wire or connection. Replace if necessary with high temperature wire.✗ b. Check for low gas supply pressure. If necessary, replace ignition control module.✗

Parts List, AH/1E

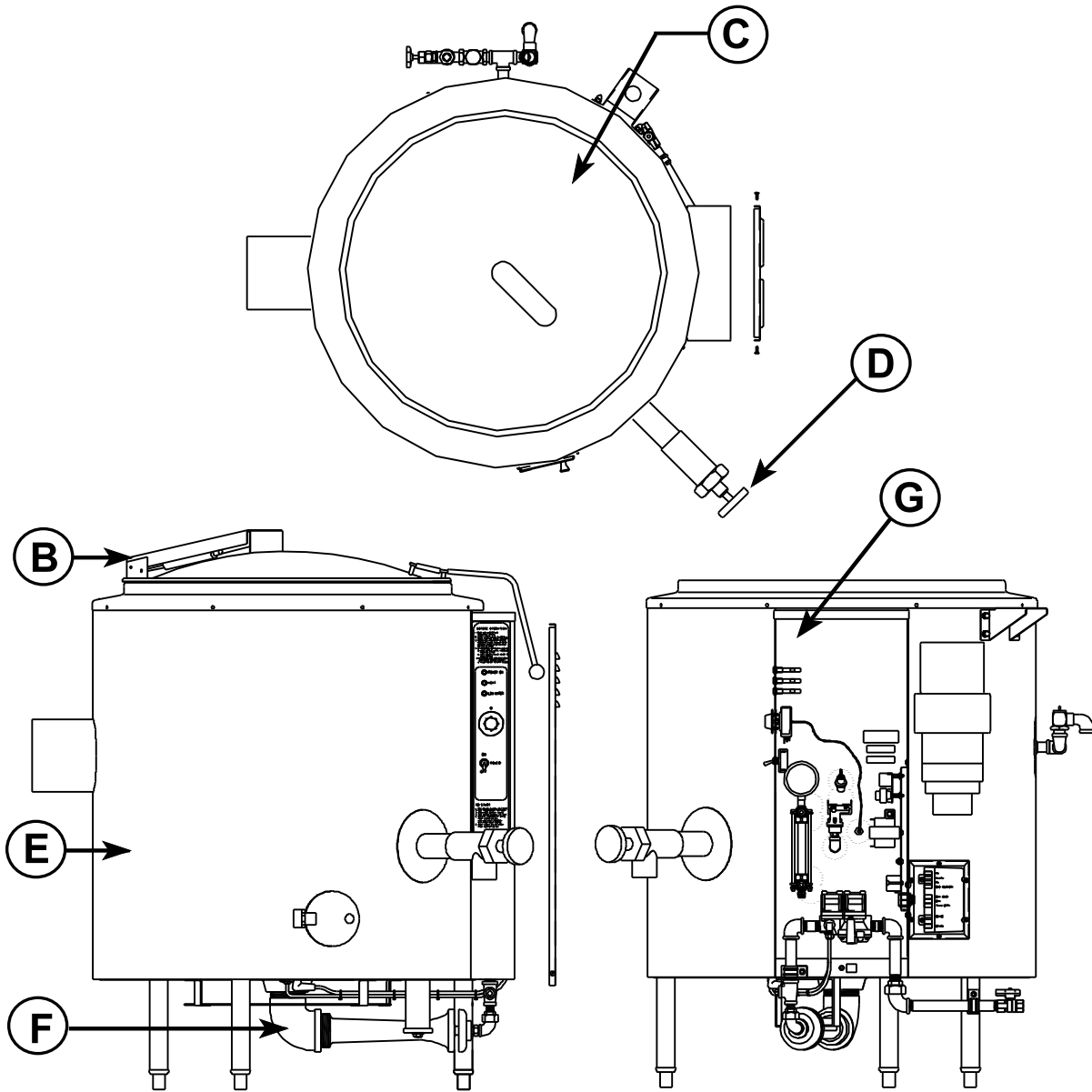

Parts List — AH/1E

To order parts, contact your Groen Certified Service Agency. Supply the model designation, part description, and number, quantity, and where applicable, voltage and phase.

Key	Description	Part No.	Key	Description	Part No.
A.	Hardware ASM AH/1E-40 Spark Ignition	117095		Safety Valve and Water Fill Assy	097010
	Bracket, Gas Manifold 1/8 x 1 x 15-3/4" lg	002006		Safety Valve 30 PSI 1/2" NPT	097009
	Nameplate Class II 1" x 4-1/2" long	003479		Elbow 90 Deg Street 1/2" NPT Black	096905
	Hinge, Spring Loaded 18 Ga x 1 x 1-1/4"	004114		Plug Pipe 1/2" NPT	011146
	Clamp Bar Pipe 1/4" x 1 x 4-1/2" lg w/stud	004568		Elbow 90 Deg Street 1/2" NPT	004185
	Door Insulated Pilot Light Assy	008201		Tee, 1/2" NPT	008772
	Plate, Caution 1-3/8 x 2-1/4"	008350		Valve Swing Check 1/2" NPT	004187
	Chain Single, Jack Link #16 600" long	009009		Nipple, 1/2" NPT x Close	008877
	Screw, Sheet Metal pan hd #12 x 1/2" lg	008769		Valve, Gate 1/2" NPT	004180
	Bracket, faucet Mounting 16 Ga x 4-3/4"	009054		Label, Warning	098171
	Diverter, Draft 6" AH/1E-20 -40	012474		Wiring Diagram Label	123863
	Diverter, Draft 7" AH/1E-60 -80 -100	000576		Harness Wiring	123864
	Nut hex Keps 1/4"-20 w/shakeproof washer	012940		Nut Hex 3/8"-16	005619
	Nameplate, Groen - Large	055450		Washer, Lock #10	005619
	Label, warranties void...	059201		Washer, Lock 3/8"	005618
	Label Warning	093614		Water Treatment Kit	110324
B	Cover Power Aid Assembly	047693	E	Shell Outer/Inner Assembly	127445
C	Pot Inner Assembly		F	Burner and Sensor Assembly	
D	TDO Kit		G	Gas Valve, Pipe & Elec Assembly	127335
	Nut, Wing #10-24 for 1-1/2" & 2"	009028		Ignition Module Box Assembly	127334
	Handle, 3" Dia Sanitary & TDO Valve	127452		Electrical Panel Assembly	123823
	Strainer Assembly 9" Dia, 1/4" holes for 2"	009044			
	Handle, Sanitary DO-150	127452			

See Following Pages for Assembly Parts

Parts List — AH/1E-40

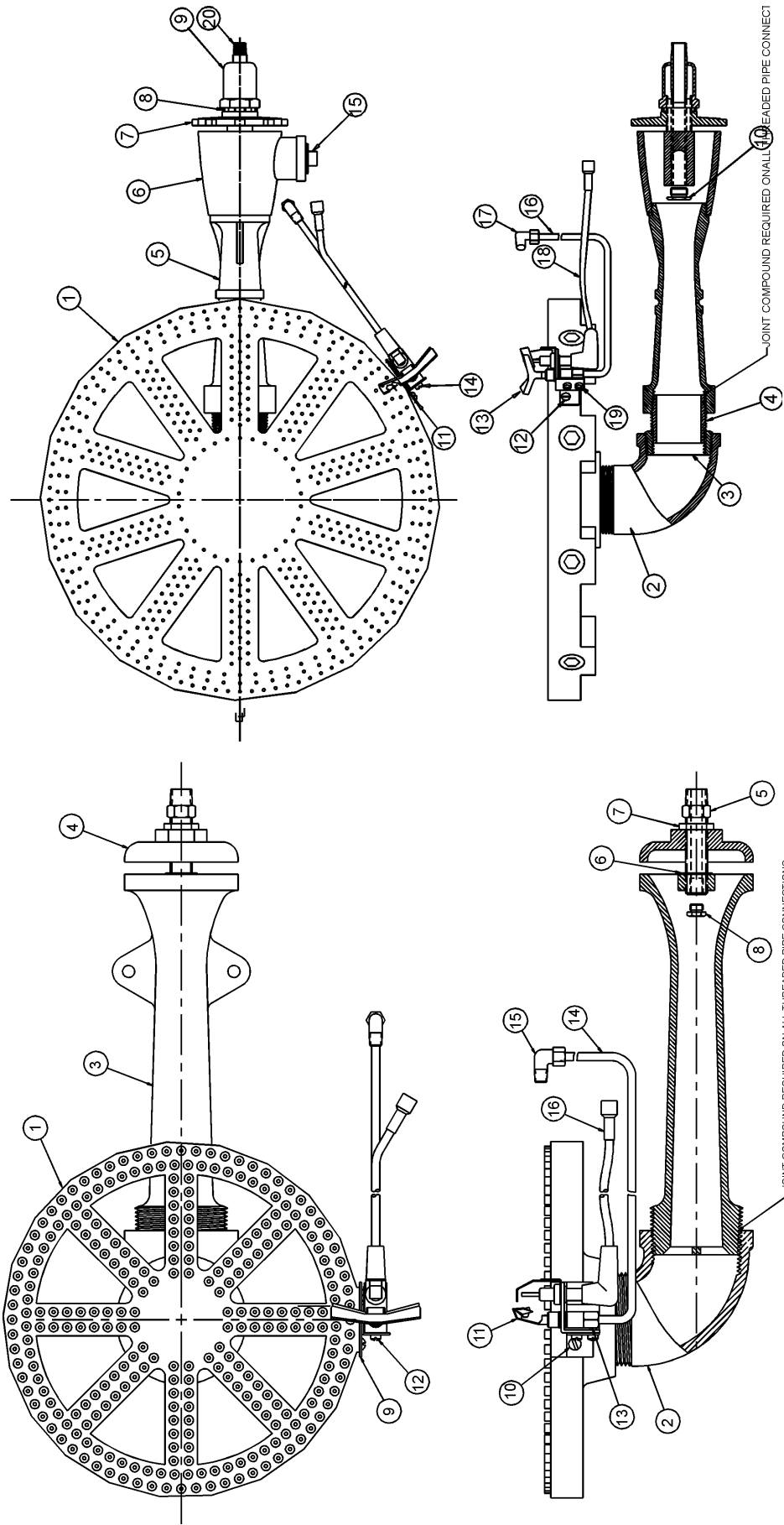

Parts List — AH-40

To order parts, contact your Groen Certified Service Agency. Supply the model designation, part description, and number, quantity, and where applicable, voltage and phase.

Key	Description	Part No.	Key	Description	Part No.
F.	Burner Assembly, AH/1E-20 & -40	127331	F.	Burner Assembly, AH/1E-60 -80 & -100	127349
1	Burner Head	000286	1	Burner Head	008246
2	90° Elbow, 2-1/2" NPT	000289	2	90° Elbow, 2-1/2" NPT	000289
3	Venturi	000287	3	Reducing Bushing, 2-1/2" x 2" NPT	08774
4	Air Shutter	000288	4	Nipple, Close 2" NPT	008731
5	Spud Orifice	000279	5	Venturi	010542
6	Retaining Ring, E type	000460	6	Mixer Head	000395
7	Lock Nut, 3/8" NPT	000294	7	Air Shutter	000396
8	Orifice, N.G., AH/1E-20, 0'-1500' elev	000489	8	Lock Nut, 3/4" NPT	000397
	Orifice, Prop, AH/1E-20 Higher Elev	000281	9	End Cap	000398
	Orifice, N.G., AH/1E-40, 0'-1500' elev	000280	10	Orifice, N.G., 0'-1500' elev	000399
	Orifice, Prop, AH/1E-40 Higher Elev	000281		Orifice, Prop, Higher Elev	000403
9	Bracket, Pilot Burner Mounting	123824	11	Bracket, Pilot Burner Mounting	123824
10	Screw #10-24 x 3/8" lg. Round Head	006009	12	Screw #10-24 x 3/8" lg. Round Head	006009
11	Pilot Burner Assy AH/1E-20, 0'-1500' el	096705	13	Pilot Burner Assy, 0'-1500' elev	096705
	Pilot Burner Assy AH/1E-20, Higher el	096706		Pilot Burner Assy, Higher elev	096705
	Pilot Burner Assy AH/1E-40, 0'-1500' el	096705	14	Screw #10-32 x 1/4 Fillister Head	090797
	Pilot Burner Assy AH/1E-40, Higher el	096706	15	Plug, pipe, square head 1" NPT	008507
12	Screw #10-32 x 1/4 Fillister Head	090797	16	Pilot Tubing, 1/4" OD aluminum	006796
13	Pilot Orifice Spud AH/1E-40, 0-1500' el	098647	17	90° male elbow 1/8" NPT x 1/4" tubing	097195
	Pilot Orifice Spud AH/1E-40, Higher el	098647	18	Hi Volt Spark Ignition Cable 36" long	096728
14	Pilot Tubing, 1/4" OD aluminum	006796	19	Pilot Orifice Spud	098647
15	90° male elbow 1/8" NPT x 1/4" tubing	097195	20	Nipple, 3/8" x 2-1/2" lg	005676
16	Hi Volt Spark Ignition Cable 36" long	096728			

Parts List

To order parts, contact your Groen Certified Service Agency. Supply the model designation, part description, and number, quantity, and where applicable, voltage

ity, and where applicable, voltage

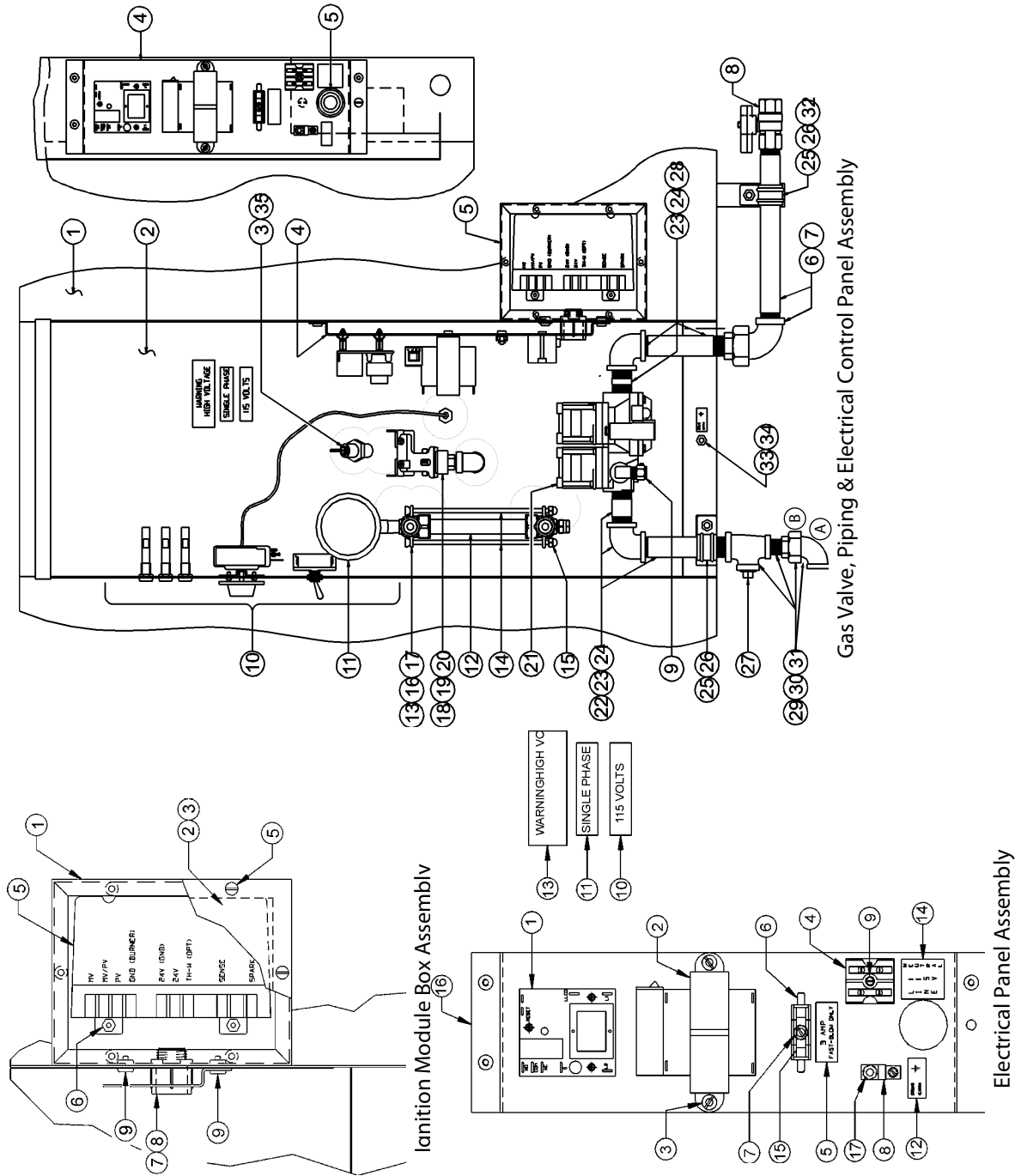

Front Panel Components Assembly

Electrical Schematic

