

OPERATOR MANUAL

Part Number 121003

OM-NGB/3

DOMESTIC

Model: NGB/3, NGB/3/E
Steam Boilers

Gas Heated
200,000 BTU/hr firing rate
120,000 BTU into product
3.7 effective boiler horsepower

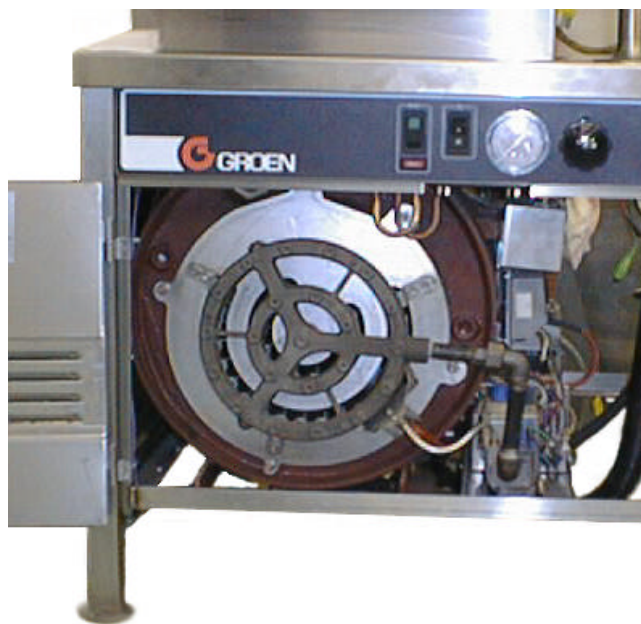

FOR YOUR SAFETY

DO NOT STORE OR USE GASOLINE OR OTHER FLAMMABLE VAPORS AND LIQUIDS IN THE VICINITY OF THIS OR ANY OTHER APPLIANCE.

READ THE INSTALLATION, OPERATING AND MAINTENANCE INSTRUCTIONS THOROUGHLY BEFORE INSTALLING, OPERATING OR SERVICING THIS EQUIPMENT.

POST IN A PROMINENT LOCATION

INSTRUCTIONS TO BE FOLLOWED IN THE EVENT USER SMELLS GAS. THIS INFORMATION SHALL BE OBTAINED BY CONSULTING YOUR LOCAL GAS SUPPLIER. AS A MINIMUM, IMMEDIATELY TURN OFF THE GAS AND CALL YOUR GAS COMPANY AND YOUR AUTHORIZED SERVICE AGENT. EVACUATE ALL PERSONNEL FROM THE AREA.

WARNING

IMPROPER INSTALLATION, ADJUSTMENT, ALTERATION, SERVICE OR MAINTENANCE CAN CAUSE PROPERTY DAMAGE, INJURY OR DEATH.



Information contained in this document is known to be current and accurate at the time of printing/creation. Unified Brands recommends referencing our product line websites, unifiedbrands.net, for the most updated product information and specifications.



IMPORTANT — READ FIRST — IMPORTANT

- WARNING:** THE UNIT MUST BE INSTALLED BY PERSONNEL QUALIFIED TO WORK WITH GAS, ELECTRICITY AND PLUMBING. IMPROPER INSTALLATION CAN CAUSE INJURY TO PERSONNEL AND/OR DAMAGE TO THE EQUIPMENT. THE UNIT MUST BE INSTALLED IN ACCORDANCE WITH APPLICABLE CODES.
- CAUTION:** AN ELECTRICAL GROUND IS REQUIRED.
- CAUTION:** DO NOT LOCATE THE BOILER CABINET DIRECTLY OVER A FLOOR DRAIN OR FLOOR SINK. HUMIDITY OR WATER FROM A DRAIN WILL DAMAGE ELECTRICAL PARTS OF A UNIT.
- WARNING:** TO AVOID DAMAGE OR INJURY, FOLLOW THE WIRING DIAGRAM EXACTLY WHEN CONNECTING A UNIT.
- CAUTION:** DO NOT USE PLASTIC PIPE. DRAIN MUST BE RATED FOR STEAM AND BOILING WATER.
- WARNING:** DO NOT CONNECT THE DRAIN DIRECTLY TO A BUILDING DRAIN.
- WARNING:** BLOCKING THE DRAIN MAY BE HAZARDOUS.
- IMPORTANT:** Improper drain connection will void warranty.
- WARNING:** ALLOW COOKING CHAMBERS TO COOL BEFORE CLEANING.
- WARNING:** CAREFULLY READ THE WARNINGS AND FOLLOW THE DIRECTIONS ON THE LABEL OF EACH CLEANING AGENT. USE SAFETY GLASSES AND RUBBER GLOVES AS RECOMMENDED BY DELIMING AGENT MANUFACTURER.
- WARNING:** DO NOT MIX DE-LIMING AGENTS (ACID) AND DE-GREASERS (ALKALI) IN THE STEAM GENERATOR OR ON THE COOKING CHAMBER WALLS.
- NOTICE:** Do not use a cleaning or de-liming agent that contains any sulfamic acid or any chloride, including hydrochloric acid (HCl). If the chloride content of any product is unclear, consult the manufacturer.
- NOTICE:** Do not use a de-greaser that contains potassium hydroxide or sodium hydroxide or that is highly alkaline.
- WARNING:** USE OF ANY REPLACEMENT PARTS OTHER THAN THOSE SUPPLIED BY GROEN OR THEIR AUTHORIZED DISTRIBUTOR VOIDS ALL WARRANTIES AND CAN CAUSE BODILY INJURY TO THE OPERATOR AND DAMAGE THE EQUIPMENT. SERVICE PERFORMED BY OTHER THAN FACTORY-AUTHORIZED PERSONNEL WILL VOID ALL WARRANTIES.
- WARNING:** HIGH VOLTAGE EXISTS INSIDE CONTROL COMPARTMENTS. DISCONNECT FROM BRANCH BEFORE SERVICING. FAILURE TO DO SO CAN RESULT IN SERIOUS INJURY OR DEATH.
- WARNING:** DO NOT EXPOSE SKIN TO ESCAPING STEAM. SEVERE BURNS CAN RESULT.

Table of Contents

OPERATOR WARNINGS 2

EQUIPMENT DESCRIPTION 4

WATER CONDITIONING REQUIREMENTS 4

INSTALLATION INSTRUCTIONS 5

INITIAL START-UP 6

OPERATING INSTRUCTIONS 7

SEQUENCE OF OPERATION 8

CLEANING AND MAINTENANCE PROCEDURES

 CLEANING 9

 MAINTENANCE 11

 TROUBLESHOOTING 12

DIAGRAMS 15

SCHEMATICS 18

REFERENCES 20

SERVICE LOG 21

NOTES 22

WARRANTY PROTECTION 23

Equipment Description

Groen NGB/3 and NGB/3/E steam boilers generate low pressure steam for use with HyPlus cabinet-mounted steamers and steam jacketed kettles. The models are distinguished by their ignition systems. The NGB/3 uses a standing pilot and the NGB/3/E uses a spark ignition system.

The boiler is housed in a stainless steel cabinet. Various combinations of steam-operated kettles and steamers can be mounted on the top. The boiler is small enough to fit in a 24-1/8" wide by 34-3/16" deep by 29-3/16" tall (maximum) cabinet.



The boiler is constructed of 1/4" thick steel, which is certified by the American Society of Mechanical Engineers (ASME) for pressure vessels. All welds are hydrostatically tested. The boiler is also equipped with required instruments, fittings, and controls.

Heat transfer fins inside the combustion chamber add to the unit's high efficiency. The NGB/3 and NGB/3E are both rated as 60% efficient or better, with a firing rate of 200,000 BTU per hour using natural or propane gas. Energy output is 120,000 BTU per hour, with an effective boiler horsepower of 3.7.

Water Conditioning

It is essential that the boiler be supplied with water that will not form scale at an unacceptable rate. The boiler was engineered to minimize scale, but its formation depends on water hardness and how much the unit is used.

In some areas of the United States the water is low enough in mineral content to avoid scale build-up. However, most water supplies carry heavy loads of minerals. This will form scale on the boiler, reduce its steam output, and possibly cause premature component failure.

Your water utility can tell you about the minerals in your water. The water going to the steam generator should have between 1 and 30 parts per million total dissolved solids (TDS) and should have a pH (acidity rating) of 7.0 or higher.

Please follow these simple precautions:

1. **Do not rely on unproven water treatment equipment** which is sold for scale prevention or scale removal. **They frequently don't work.** The best way to prevent scale is to supply the purest possible water.
2. If your water contains scale-forming minerals, as most water does, use a well-maintained water softener. Whether an exchangeable softener cartridge or a regenerating system is chosen, a regular exchange system is essential.
3. Installing a water meter between the softener and the steamer will provide an accurate gauge of water use, and will help determine when to exchange cartridges or regenerate the softener. Using a water softener will provide longer

generator life, higher steam capacity, and reduce maintenance requirements.

4. If you notice a slowdown in steam production, check the boiler for scale build-up. Heavy scale reduces the unit's ability to boil water, and can even cause heating elements in the steam generator to overheat and burn out.
5. Groen gas and electric pressure boilers are available with two separate water intakes:

one for the boiler (soft water)
one for the spray condenser (untreated water).

The steam generator only uses 14 to 31% of a steamer's water. Since softener systems are typically sized by total GPH (gallons per hour), the second intake could reduce treatment requirements by up to 80%, resulting in significant savings.

Reduce scale problems by using and maintaining a water softener for your steamer !

Installation

WARNING

THE UNIT MUST BE INSTALLED BY PERSONNEL WHO ARE QUALIFIED TO WORK WITH GAS, ELECTRICITY AND PLUMBING. IMPROPER INSTALLATION CAN CAUSE INJURY TO PERSONNEL AND/OR DAMAGE TO THE EQUIPMENT. THE UNIT MUST BE INSTALLED IN ACCORDANCE WITH APPLICABLE CODES.

Getting Started

WHEN THE UNIT IS RECEIVED, IMMEDIATELY INSPECT IT FOR EXTERNAL OR INTERNAL DAMAGE. REPORT ANY DAMAGE TO THE FREIGHT CARRIER.

After inspection, keep the unit in its shipping container until it is installed. It can be installed on combustible and non-combustible floors. Minimum clearances are:

Right Side — Two inches
Left Side — Four inches
Rear — Six inches

In order to service the unit properly, access with at least 24 inches clearance is needed on the right side.

Install the unit in a well-vented room so that there is an adequate air supply. Since products of combustion come out of its flue, the appliance must be located under a ventilation hood. **Do not directly vent the flue.**

Level the unit front to rear and left to right by adjusting its legs. Levelness may be checked by using a spirit level on top of the cabinet.

A free flow of air around the boiler promotes efficient operation. Items which might restrict air flow must be removed. After installation, do not obstruct the flue, or any front, side, rear or top vents. Similarly, keep the area directly around the appliance clear of combustible material.

Installation must conform with local codes, or in the absence of local codes, with the National Fuel Gas Code, ANSI Z223.1 (latest edition, including the following paragraph:

“The unit and its individual shut-off valve must be **disconnected** from the gas supply piping system during any pressure testing of that system at test pressures in excess of ½ PSI (3.45 kPA). The unit must be **isolated** from the gas piping system by closing its individual manual shut-off valve during any pressure testing of the gas supply piping system at test pressures **equal to or less than** ½ PSI (3.45kPA).”

CAUTION

MAKING ANY ELECTRICAL OR MECHANICAL CHANGE IN THE UNIT WITHOUT PRIOR GROEN APPROVAL WILL VOID ALL WARRANTIES.

1. Gas Supply Connection

- a. Connection to the gas supply can be completed with 1/2" NPT pipe or approved equivalent. Although this is the diameter for immediate connection to the unit, **gas supply piping must be large enough to provide volumes and pressure sufficient for 200,000 BTU per hour.** Supply pressure must be at least 5.0" W.C. (14.0" W.C. maximum) for natural gas or 11.0 W.C. (14.0" W.C. maximum) for propane.
- b. In Canada, the installation must conform to the Canada Gas Code, CAN 1-B149 (*Installation Codes for Gas Burning Appliances and Equipment*), and/or local codes.
- c. After the unit has been connected to the gas supply, check piping joints for leaks. Do NOT use flame to check for leaks. A thick soap solution or other suitable leak detector should be used.

2. Electrical Supply Connection

- a. The maximum electrical load is 4 AMP. You must provide 115 Volt Alternating Current, 60 Hz, 1PH, 15 AMP service. Local codes and/or the National Electrical Code should be followed (ANSI/NFPA-70-1987 - or latest edition). **AN ELECTRICAL GROUND IS REQUIRED.**
- b. Copies of the electrical schematic are located in the electrical enclosure on the equipment and in this manual. In Canada, electrical service must comply with the Canadian Electrical Code, CSA C22.1, Part 1, and/or local codes.

3. Water Connection

- a. Cold water is supplied via a 1/2" NPT pipe connection at the rear of the unit. A check

OM-NGB/3

valve (back siphonage device) must be installed in accord with local plumbing codes.

- b. Water pressure should be between 30 and 60 PSI. If it is over 60 PSI, a pressure regulator is required. A strainer screen at the connection is also recommended, to trap any debris before it can enter the system.
- c. The NGB/3 boiler uses a maximum of 12.9 gallons of water per hour. Piping should be sized to handle total water consumption.

4. Drain Connection

- a. The drain connection is made at the rear of the unit with 1 - 1/4" NPT pipe. **DO NOT USE PLASTIC PIPE. DRAIN PIPING MUST WITHSTAND STEAM AND BOILING WATER.** Extend the drain piping to a nearby floor drain. Piping of 1 - 1/4" NPT (or 1 - 1/2" NPT) is acceptable for distances of six feet or less. If the distance to the drain is further than six feet, use 2" NPT piping.
- b. The drain line must be installed with a constant downward pitch. Do not permit any water traps in the line. **DO NOT CONNECT THE LINE DIRECTLY TO ANY BUILDING DRAIN.** A vertical air gap of at least two inches must be maintained between the drain line and the building drain unless otherwise specified by local plumbing codes.

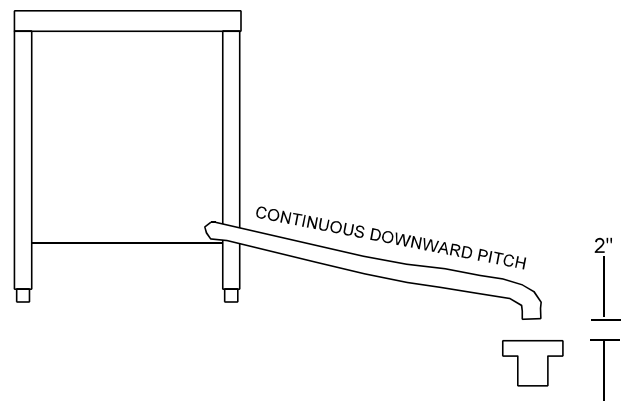
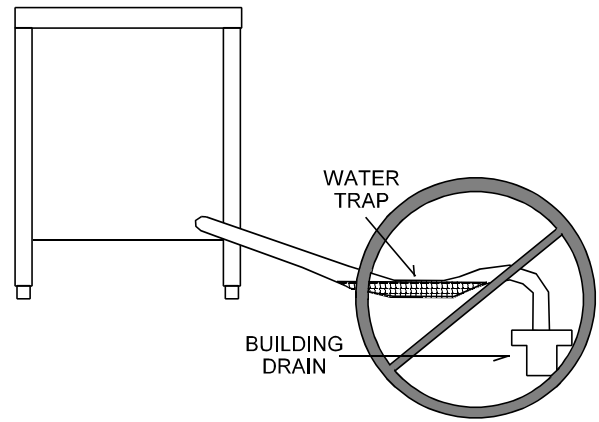

Leave a two-inch air gap between the hose and the building drain, and don't allow water traps in the line.

CAUTION
DO NOT LOCATE THE BOILER CABINET DIRECTLY OVER A FLOOR DRAIN OR FLOOR SINK. HUMIDITY OR WATER FROM WILL DAMAGE ELECTRICAL.

IMPORTANT: Improper drain connection will void warranty.

Initial Start-Up

After the unit has been installed, test it to ensure that it is operating properly.

1. Remove literature and packing material from the interior and exterior of the unit.
2. Make certain the water supply is turned on.
3. Turn on electrical power to the unit.
4. Make sure the gas supply line is open, and turn on the gas valve.
 - a. **For NGB/3:** Turn the knob on the gas valve to "PILOT," then push the knob inward and hold, while lighting the pilot burner. Continue to hold the knob in for about 60 seconds after the pilot burner lights, so that the thermocouple energizes, and the pilot stays lit. Release the knob and turn it to the "ON" position.
 - b. **For NGB/3/E:** Turn the knob on the gas valve to the "ON" position.

NOTE: On NGB/3/E, the "trial for ignition" period is approximately 90 seconds after the on/off switch is turned to the "ON" position. (Refer to the Control Panel illustration in the Operation Section).

During initial start-up several trials may be necessary to remove air from the gas piping. Subsequent start-ups should only need about five seconds for the pilot to light. If the pilot burner does not light within the trial period, the ignition system will automatically stop gas flow to the pilot burner, and terminate the ignition trial. If this happens, turn the switch to "OFF" and then "ON" again, to repeat the trial for ignition.

5. Turn the on/off switch on the cabinet front panel to the "ON" position:
 - The amber light in the switch will come on
 - The boiler drain valve will close
 - The unit will fill with water

When the water level reaches the "mid" probe, the red RESET light will come on. Push the start switch.

- The green light in the switch will come on
- The RESET light will go out
- The main burner will light

When the water level reaches the "hi" probe, the water supply to the boiler will shut off.

6. After about 15 minutes, the pressure on the gauge will rise. When the pressure reaches 9-1/2 PSI, the main burner will turn off. Thereafter, as pressure decreases, the burner will automatically re-light to maintain the 9-1/2 PSI level. The pilot burner should stay lit, even though the main burner cycles on and off.
7. To shut the unit down, turn the on/off switch to OFF. When it has cooled to approximately 170°F, the unit will automatically drain.

If desired, the pilot burner may also be turned off at the gas valve on the NGB/3 (standing pilot), to conserve energy during idle periods.

On the NGB/3/E (spark ignition) boiler, the pilot is off when the on/off switch is OFF.

If the unit functions as described above, it is ready for use. If it does not, contact your authorized Groen Service Agent..

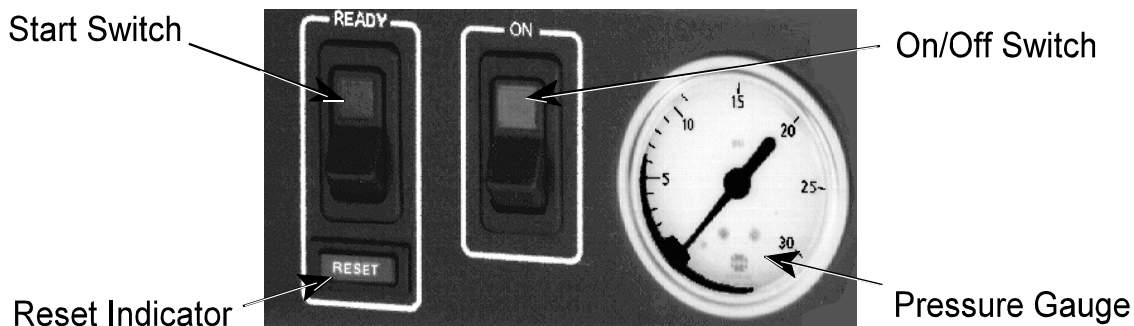

Operating Controls are located on the front of the cabinet base unit.

Operation

WARNING

ALL POTENTIAL USERS OF THE EQUIPMENT MUST BE TRAINED IN SAFE AND CORRECT OPERATING PROCEDURES

1. Controls

Operating controls are located on the front panel of the unit.

- a. The on/off switch starts the unit or shuts it off.
- b. The RESET indicator lights to show that the boiler has filled with water and that the main burners can ignite.
- c. The start switch (momentary) lights the main burners. It also restarts the unit if electrical power is interrupted, or if a low water condition in the boiler disables the unit.

In addition to operating these controls, there are gas supply controls located on the gas valve.

- a. **For NGB/3:** The control knob is turned to the "PILOT" position and held down to light the pilot burner. If the pilot remains lit when the control knob is released, the knob may be turned to the "ON" position. This lets gas flow to the main burners. When the knob is turned "OFF," gas flow stops to both the pilot and main burners.
- b. **For NGB/3/E:** When the control knob is "ON," gas flows to the pilot, as well as to the main burners.

2. Operating Procedure

- a. Turn on the water supply to the unit.
- b. Turn on electrical power to the unit.
- c. Turn on the gas supply to the unit, and turn on the gas valve.
 - 1) **For NGB/3:** Turn the gas valve control knob to the "PILOT" position. Depress the knob and light the pilot burner. Keep the knob depressed for about 60 seconds after the pilot lights, to allow the thermocouple (which controls gas flow to both the burners and the pilot) to heat up. When the knob is released, the pilot burner will remain lit. Turn the control to the "ON" position.
 - 2) **For the NGB/3/E:** Turn the control knob on the gas valve to the "ON" position.

NOTE On the NGB/3/E the "ignition trial" period runs for approximately 90 seconds after the on/off switch is turned ON. This means that if the pilot light does not light within the "trial" period, the ignition system will automatically stop the gas flow and

terminate the ignition trial. If ignition is terminated, turn the switch off and then "ON" again to repeat the trial. Normally, the pilot should light within five seconds of turning on the unit.

- d. Turn the on/off switch on the front of the cabinet to "ON."
 - 1) The amber light will come on.
 - 2) The boiler drain valve will close and the unit will fill with water.
 - 3) When the water reaches the "mid" probe, the red RESET light will come on.
 - 4) Press the start switch.
 - 5) The green light in the switch will come on, the RESET light will go off, and the main burner will light.
 - 6) When the water level reaches the "hi" probe, the water supply to the boiler will shut off.
- e. After about 15 minutes, the pressure gauge will indicate that the pressure is rising. When it reaches 9-1/2 PSI, the main burner will shut off. Thereafter, the burner will periodically re-light to maintain the pressure at 9-1/2 PSI. The pilot light should stay lit when the burner is off.
- f. To shut down the unit, turn the on/off switch to OFF. The unit will drain automatically after it has cooled to about 170°F. When the NGB/3 (standing pilot) unit will be idle for extended periods, the pilot burner may be turned off at the gas valve to conserve energy. The NGB/3/E (spark ignition) turns off the pilot light when the on/off switch is turned to OFF.

Sequence of Operation

When electrical power is turned on to the unit, the following happens:

- The drain valve closes
- The water valve opens
- The unit fills with water

As the boiler fills, the water is detected by two probes. The first of these is the “mid” probe, which activates the RESET light. The second (“hi” probe) is reached when the boiler is full, and shuts off the water supply. As the water supply drops below this probe, the water supply opens until it is again reached.

The gas valve has a step-opening feature. When the control calls for the main burner to light, the outlet pressure of the valve is maintained at a preset (non-adjustable) rate for several seconds, before full rated pressure is allowed to develop.

Once the main burner shuts down, step-opening gas valves need at least 60 seconds to reset. If an attempt to re-light the burner is made before these valves reset, it may bypass or shorten the length of the low pressure step, and could re-light the main burner under full flow rate.

CAUTION

WAIT AT LEAST 60 SECONDS BEFORE ATTEMPTING TO RE-LIGHT THE MAIN BURNER AFTER IT SHUTS OFF.

A thermostatically-controlled air vent remains open while the boiler fills. As steam begins to develop, this vent will close. Some steam may escape from this vent before it is fully closed (at approximately 200°F).

Once the pressure has reached 9-1/2 PSI, the main burner will be shut off by an operating pressure switch. Residual heat stored in the boiler’s heat exchanger can, however, cause the pressure to continue to build, even after the burner has shut down. This is especially true when the unit is heated for the first time.

If/when the pressure reaches 12 PSI, a relief valve will open to prevent pressure from increasing past 12 PSI. As pressure decreases, the main burner will automatically re-light to maintain 9-1/2 PSI.

Even if something causes the pressure to pass 12PSI, a high-limit safety switch will shut down the boiler electrically when it reaches 14-1/2 PSI. If this happens, the unit should not be re-started until the

problem which caused the shut-down has been corrected.

As an additional safety measure, the unit is equipped with an A.S.M.E.-certified safety valve which will open to relieve excess pressure at 15 PSI. The ability of this valve to discharge steam pressure is greater than the boiler’s ability to generate steam.

When electrical power is turned off, the gas valve automatically shuts off flow to the main gas burner.

A thermostatic switch (mounted on the boiler shell) keeps the drain valve closed until the temperature drops to approximately 170°F.

At that point, the thermostatic switch opens and water drains from the boiler. A vacuum breaker allows air to enter the boiler for this purpose.

Cleaning

Whenever the boiler is turned off and allowed to cool to about 170 °F, it drains automatically. This should be done every day to minimize scale build-up inside the boiler.

In addition to this draining, however, the following cleaning procedure should be followed using a regular schedule. This will prevent the accumulation of lime on the water level probes and interior surfaces of the boiler. The actual time between these scheduled cleanings depends on the water quality and hours of operation. Minimally, Groen recommends cleaning the boiler at least once each month.

A. Suggested Tools

1. 1/2" hardened square wrench extension
2. Pipe Joint compound
3. 32 oz. **Groen** Delimer Descaler (PN 114800), Lime-A-Way or equivalent
4. **Groen** Spray Degreaser (PN 114801, or equivalent)
5. Nylon pad(s)

B. Procedure



WARNING
WATER AND VALVES MAY BE VERY HOT,
AND MAY CAUSE BURNS. PROTECT HANDS
FROM HOT SURFACES AND WATER.

1. Turn the boiler on/off switch to the OFF position.
2. Slowly open the manual drain valve to empty the boiler. The valve is located under the boiler.
3. Close the manual drain valve.
4. Turn off water supply to the boiler.
5. Allow the boiler to cool. This takes several hours, so it is recommended that you cool the boiler overnight.
6. Turn on/off switch to "ON" to close the automatic drain valve.
7. Using a 1/2" hardened square wrench extension, remove one of the 1" NPT pipe plugs from the front of the boiler.



The manual drain valve is located under the boiler.



WARNING
USE SAFETY GLASSES AND RUBBER
GLOVES AS RECOMMENDED BY DE-LIMING
AGENT MANUFACTURER.

8. Pour 32 ounces of de-limer (**Groen** Delimer Descaler - Part Number 114800), Lime-a-Way® or equivalent) into the boiler.

CAUTION
 DO NOT USE A CLEANING OR DE-LIMING AGENT THAT CONTAINS SULFAMIC ACID OR ANY CHLORIDES, INCLUDING HYDROCHLORIC ACID (HCL). IF THE CHLORIDE CONTENT OF ANY PRODUCT IS UNCLEAR, CONSULT THE MANUFACTURER.

9. Replace the pipe plug. Use pipe joint compound, and tighten the plug securely.
 10. Turn on water supply to allow water to fill the boiler.
 11. When the reset light appears, press the START switch.
 12. Allow boiler pressure to develop. Let it stand for approximately 15 minutes after pressure has built up. A badly limed unit may require more than 15 minutes.
- If there are no steamer cavities or compartments with this boiler, proceed to step 19.*
13. Set steamer timers for 10 minutes.
 14. When steamer timers sound, turn them to OFF and open the doors.
 15. When the fans have stopped, remove fan baffle partitions **using protective gloves**, and rinse with clean water.

16. Completely wipe out steamer chambers using a degreaser and nylon pad, if necessary. Rinse thoroughly with clean water.
17. Replace fan baffle partitions.
18. Wait 10 minutes for the compartments to air dry, then close the steamer doors.
19. Turn the on/off switch OFF, and slowly open the manual drain valve.



WARNING
SOLUTION AND VALVES WILL BE VERY HOT,
AND MAY CAUSE BURNS. PROTECT HANDS
FROM HOT SURFACES AND CONTINUE TO
USE PROTECTIVE GLOVES.

20. When the boiler has drained completely, close the manual drain valve and turn the on/off switch to "ON" to fill the boiler with water.
 21. After the RESET light comes on, press the start switch.
 22. Allow boiler pressure to develop
- If steamers are not present, proceed to step 25.*
23. Set steamer timers for 10 minutes.
 24. When steamer signal sounds, turn timers off.
 25. If the boiler is not to be used, it may be turned off. It is ready for normal operation.

Maintenance

Your Groen boiler is designed to minimize maintenance, but certain parts may need to be replaced after prolonged use. For the most part, no user adjustments should be necessary. If a need for service arises, only Groen personnel or Authorized Groen Representatives should perform the work.

Among the most common problems is the rapid build-up of scale in the boiler. To avoid this, **always supply water that has a low mineral content**, which meets the standards described in the **Water Conditioning** section of this manual.

WARNING
USE ONLY GROEN-SUPPLIED PARTS. USING SUBSTITUTE, UNAUTHORIZED OR "GENERIC" PARTS CAN CAUSE BODILY INJURY TO THE OPERATOR AND DAMAGE THE EQUIPMENT.

Periodic Inspection

The unit should be inspected by a qualified service technician at least once each year. The inspection should include electrical wires and connections, cleaning the inside of the control enclosure and pilot burner adjustment, if required.

At the back of this manual (with the information about our warranty) is a Maintenance and Service Log. Each time maintenance is performed on the unit, enter the date on which it was done, what was done, and who did it. Keep this log with the warranty.

In addition to yearly inspections by a qualified service technician, a weekly check of the following will help prevent down time and ensure continued efficient operation.

1. Pressure gauge operation
2. Proper water level (gauge)
3. Strainer in water feed line (clear?)
4. Air inlets for gas burner jets (clean?)
5. Pilot burner flame (blue? Envelops sensor?)
6. Drain piping (free running? No blockage?)

At least twice each month, check the safety valve to be sure it is working properly. When pressure reaches five PSI on the gauge, lift the lever to vent steam, then release it, allowing it to snap back into place.



WARNING
DO NOT EXPOSE SKIN TO ESCAPING STEAM. SEVERE BURNS MAY RESULT.



The safety valve is located on the top left rear of the boiler.

Component Replacement

NGB/3 and NGB/3/E boilers are easy to service. The design is simple, and controls are readily accessible.

Before replacing any part, **COMPLETELY SHUT OFF THE GAS AND ELECTRICAL POWER TO THE UNIT.** When breaking (opening) a gas pipe connection, allow five minutes for gas to dissipate before proceeding.

When the pipes have been reconnected, check for leaks with a thick soap solution or other suitable leak detector. **Do not use flame to check for gas leaks.**

Troubleshooting

Do not operate the unit if it malfunctions or has damaged or broken parts.

NGB/3 and NGB/3/E steam boilers are designed to operate smoothly and efficiently when maintained properly. However, the following is a list of checks to make if there is a problem. Electrical schematics are provided in this manual, and inside the unit electrical enclosure. **IF THE ITEM ON THE LIST IS MARKED WITH (X), THE WORK SHOULD ONLY BE DONE BY A FACTORY-AUTHORIZED SERVICE REPRESENTATIVE.**

SYMPTOM	WHO	WHAT TO CHECK
		Items marked with (X) should only be done by a factory-authorized service rep.
Boiler does not fill with water	User can check	a. Is water supply connected and is water present? b. Is water pressure low (less than 30 PSI)? c. Is strainer screen (if used) clogged? d. Is on/off switch in base cabinet turned on? Is the amber light in the on/off switch "ON"? e. Is the manual drain valve open?
	Auth Service Rep Only	f. Is the Water Level Control Board (PCB) defective? Check for loose electrical connections on water fill solenoid. (X) g. Is the water fill solenoid valve defective? (X) h. Is the solenoid drain valve open or leaking? Check for loose electrical connections on solenoid drain valve. (X)
Boiler overfills with water	User can check	a. Is the boiler level? Check levelness of unit with a spirit level. b. Is the water pressure too high? (Greater than 60 PSI?)
	Auth Service Rep Only	c. Is the Water Level Control Board (PCB) defective? Check for loose electrical connections on "hi" water fill solenoid. (X) d. Is the water fill solenoid valve defective? (X) Check for debris on valve seat. e. Is the "hi" water probe sensing level? Clean water level probe and probe well (located in boiler). (X)
Boiler underfills with water	User can check	a. Is the boiler level? Check levelness of unit with a spirit level.
Water enters boiler slowly.	User can check	a. Is strainer screen (if used) clogged? b. Is the water pressure too low? (Less than 30 PSI)? c. Is the water supply line too small?
	Auth Service Rep Only	d. Is the water fill solenoid defective? (X)
RESET light does not come on	Auth Service Rep Only	a. Is the Is the Water Level Control Board (PCB) defective? Check for loose electrical connections on "mid" water fill solenoid. (X) b. Is the "mid" water probe sensing level? Clean water level probe and probe well (located in boiler). (X) c. Is the indicator light defective? (X)
Pilot burner will not light (standing pilot)	User can check	a. Is supply gas valve open? b. Is gas valve in "pilot" position and knob depressed when lighting the pilot?
	Auth Service Rep Only	c. Does the pilot flame require adjustment? Screw attachment on gas valve (X) d. Is the gas valve defective? (X)

OM-NGB/3

SYMPTOM	WHO	WHAT TO CHECK Items marked with (X) should only be done by a factory-authorized service rep.
Pilot burner will not light (spark ignition)	User can check	a. Is supply gas valve open? b. Is gas valve knob in the "ON" position? c. Is the boiler filled with water? Is the green light in the start switch "ON"?
	Auth Service Rep Only	d. Does the pilot flame require adjustment? Screw attachment on gas valve (X) e. Is the gas valve defective? (X)
Pilot burner will not stay lit (standing pilot and spark ignition)	Auth Service Rep Only	a. Does the pilot flame require adjustment? Screw attachment on gas valve (X)
Main burner will not light (standing pilot)	User can check	a. Is pilot burner lit? b. Is gas valve knob in the "ON" position? c. Is the boiler filled with water? Is the green light in the start switch "ON"?
	Auth Service Rep Only	d. Is the thermocouple defective (X) e. Is the gas valve defective (X)
Main burner will not light (spark ignition)	User can check	a. Is pilot burner lit? b. Is the boiler filled with water? Is the green light in the start switch "ON"?
	Auth Service Rep Only	c. Is the igniter-sensor defective? (X) d. Is the gas valve defective (X) e. Is the spark ignition module defective? (X)
Boiler does not build pressure with main burner lit.	User can check	a. Is the steam power take-off valve open or leaking? b. Is the pressure gauge defective?
	Auth Service Rep Only	c. Is the air vent leaking steam? (X) d. Is the solenoid or manual drain valve open or leaking? NOTE: Excessive make-up water added to the boiler reduces steam production. (X) e. Is the burner BTU output low? Check the gas pressure at the burner. Adjust at the gas valve, if necessary. (X)
Main burner does not shut off after reaching operating pressure.	User can check	a. Is the pressure gauge defective? b. Is the gas valve defective?
	Auth Service Rep Only	c. Is the operating pressure switch defective? No adjustment is allowed. Replace the switch if defective. (X)
Boiler builds pressure but shuts down. RESET light comes on.	User can check	a. Is the water level below the "mid" water level probe? Verify that the water supply is sufficient to maintain the water level at or above the "mid" water level probe.
	Auth Service Rep Only	b. Is the operating pressure switch defective? No adjustment is allowed. Replace the switch if defective. NOTE: If the high-limit pressure switch has shut down the unit, it should not be restarted until the problem which caused the shut-down has been corrected. (X) c. Is the "mid" water level probe unable to detect water? Clean the water level probe and probe well (located in the boiler). (X)
Safety relief valve opens.	Auth Service Rep Only	a. Are the operating pressure switch and/or high-limit pressure switch defective? No adjustment is allowed. Replace defective switches. (X) b. Is the safety relief valve defective? Replace with ASME-approved 15 PSI valve with "HV" marking. (X)

Troubleshooting (Continued)

SYMPTOM	WHO	WHAT TO CHECK Items marked with (X) should only be done by a factory-authorized service rep.
Boiler blows down immediately when turned off.	Auth Service Rep Only	a. Is the thermostatic switch defective? Check for loose electrical connections on switch. (X)
Boiler does not drain.	User can check	a. Is the thermostatic switch defective? b. Is the solenoid drain valve defective? c. Are the solenoid drain valve or hoses blocked?

Parts List NGB/3 Burner and Gas Valve

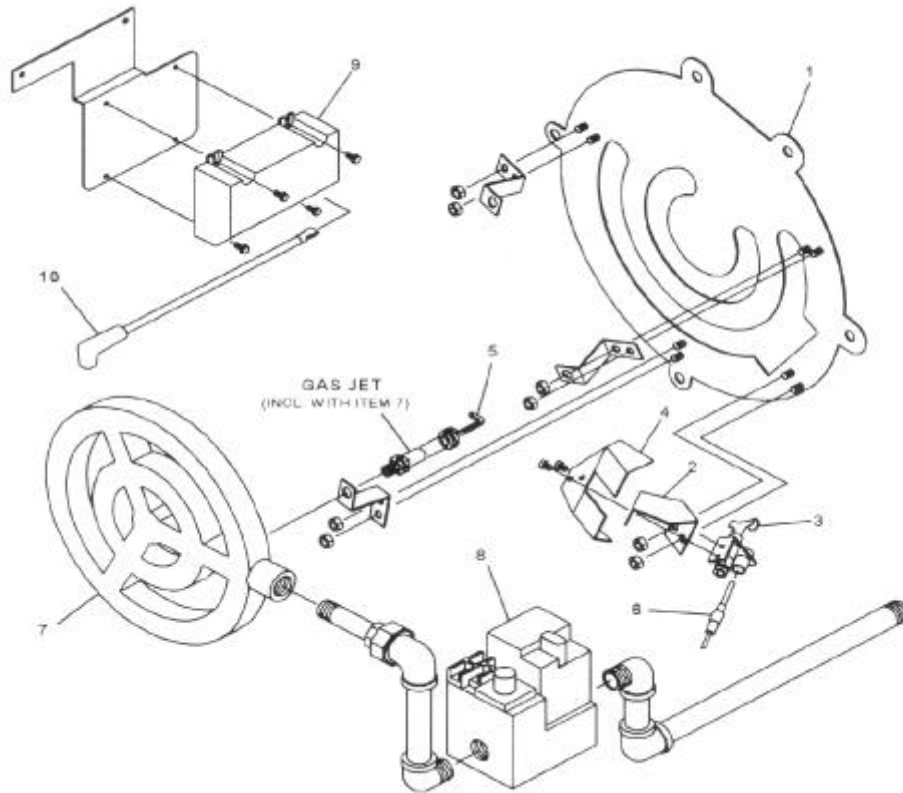

NATURAL GAS			PROPANE GAS		
Key	Description	Part No.	Key	Description	Part No.
1	Baffle Plate	083076	1	Baffle Plate	083076
2	Pilot Burner Mounting Bracket	102215	2	Pilot Burner Mounting Bracket	102215
3	Pilot Burner (Standing Pilot)	102249	3	Pilot Burner (Standing Pilot)	102250
4	Shield for Pilot Burner	102252	4	Shield for Pilot Burner	102252
5	Flame Deflector (Single Loop)	056965	5	Flame Deflector (Double Loop)	056966
6	Thermocouple (For Standing Pilot Only)	076423	6	Thermocouple	076423
7a	Main Burner Assy 0-2500 Ft. Elev. (Incl. (29) Gas Jets W/ #54 Drill Dia Hole)	047267	7a	Main Burner Assy 0-2500 Ft. Elev. (Incl (29) Gas Jets w/ #68 Drill Dia Hole)	050491
7b	Main Burner Assy 2501-5500 Ft. Elev. (Incl.(29)Gas Jets w/#55 Drill Dia Hole)	065949	7b	Main Burner Assy 2501-5500 Ft. Elev. (Incl(29) Gas Jets w/ #69 Drill Dia Hole)	065019
7c	Main Burner Assy 5501-8500 Ft. Elev. (Incl.(29)Gas Jets w/#55 Drill Dia Hole)	091938	7c	Main Burner Assy 5501-7500 Ft. Elev. (Incl(29) Gas Jets w/ #70 Drill Dia Hole)	065478
8	Gas Valve (Standing Pilot)	077973	8	Gas Valve (Standing Pilot)	082908
For Spark Ignition (Natural Gas)			For Spark Ignition (Propane Gas)		
2	Pilot Burner Mounting Bracket	102257	2	Pilot Burner Mounting Bracket	102257
3	Pilot Burner W/ Spark Igniter-sensor	102258	3	Pilot Burner W/ Spark Igniter-sensor	104392
4	Shield for Pilot Burner	102260	4	Shield for Pilot Burner	102260
8	Gas Valve (Spark Ignition)	101497	8	Gas Valve (Spark Ignition)	104391
9	Spark Ignition Module (Used with Gas Valve P/n 101497)	085153	9	Spark Ignition Module (Used with Gas Valve P/n 104391)	085153
10	Ignition Cable	085154	10	Ignition Cable	085154
--	Kit, Conversion-standing Pilot to Spark Ignition	102295			

Parts List NGB/3 Boiler

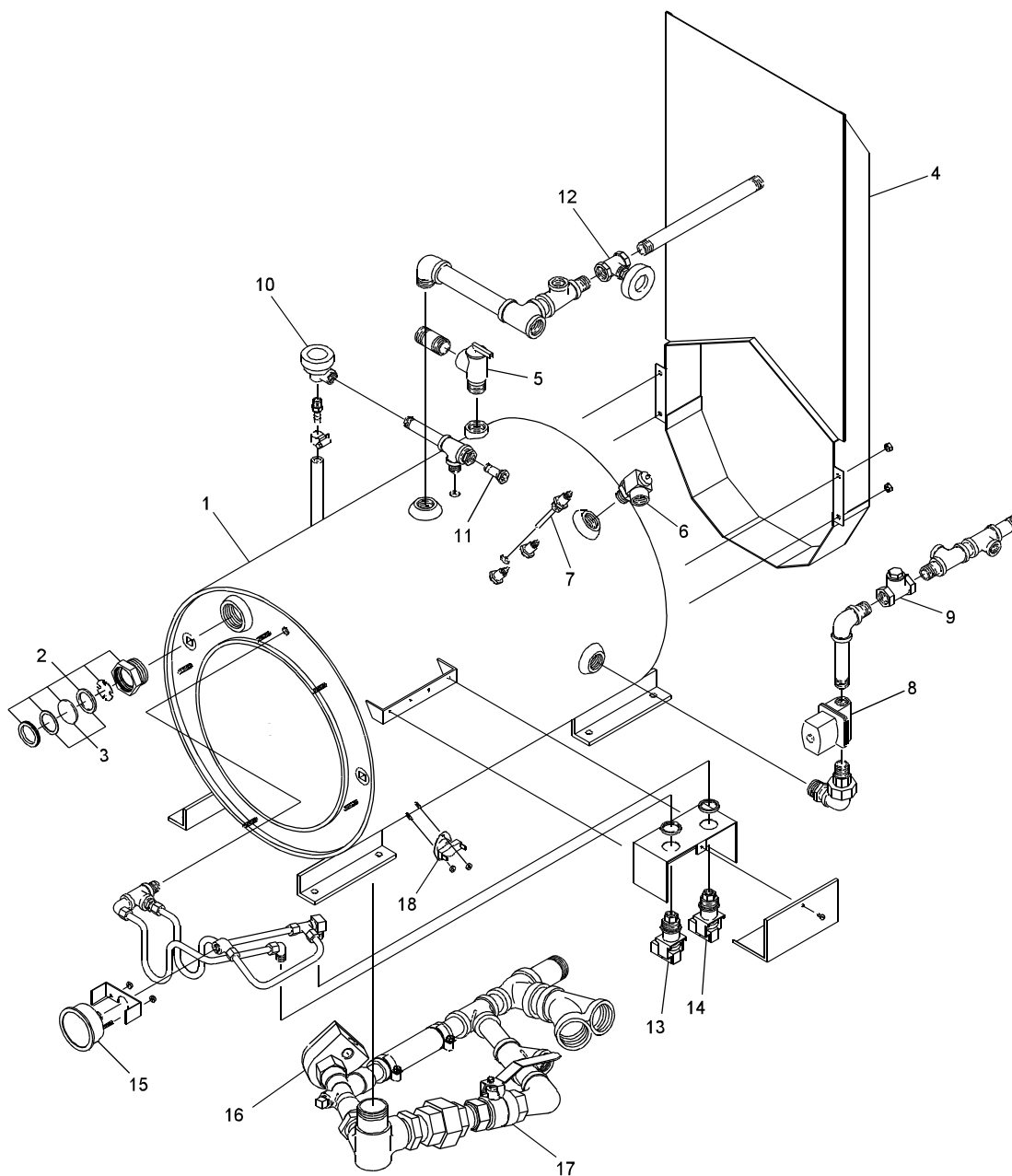

Key	Description	Part No.	Key	Description	Part No.
1	Boiler Weldment	MS98221	10	Air Vent	084098
2	Sight Glass Assembly	071534	11	Vacuum Breaker	090787
3	Kit, Repair - Sight Glass	097099	12	Globe Valve 1/2"NPT	099255
4	Flue	099217	13	Operating Pressure Switch-9½ PSI	099222
5	Safety Valve (15PSI)	102297	14	Hi-limit Pressure Switch-14½ PSI	099223
6	Pressure Relief Valve (12PSI)	099228	15	Pressure Gauge	078000
7	Water Level Probes (lo, med, hi)	076526	16	Solenoid Valve (Drain)	074594
8	Solenoid Valve (Water-in)	099220	17	Ball Valve (3/4" NPT)	009883
9	Check Valve	004187	18	Thermostatic Switch	077985

Parts List NGB/3 Electrical Controls

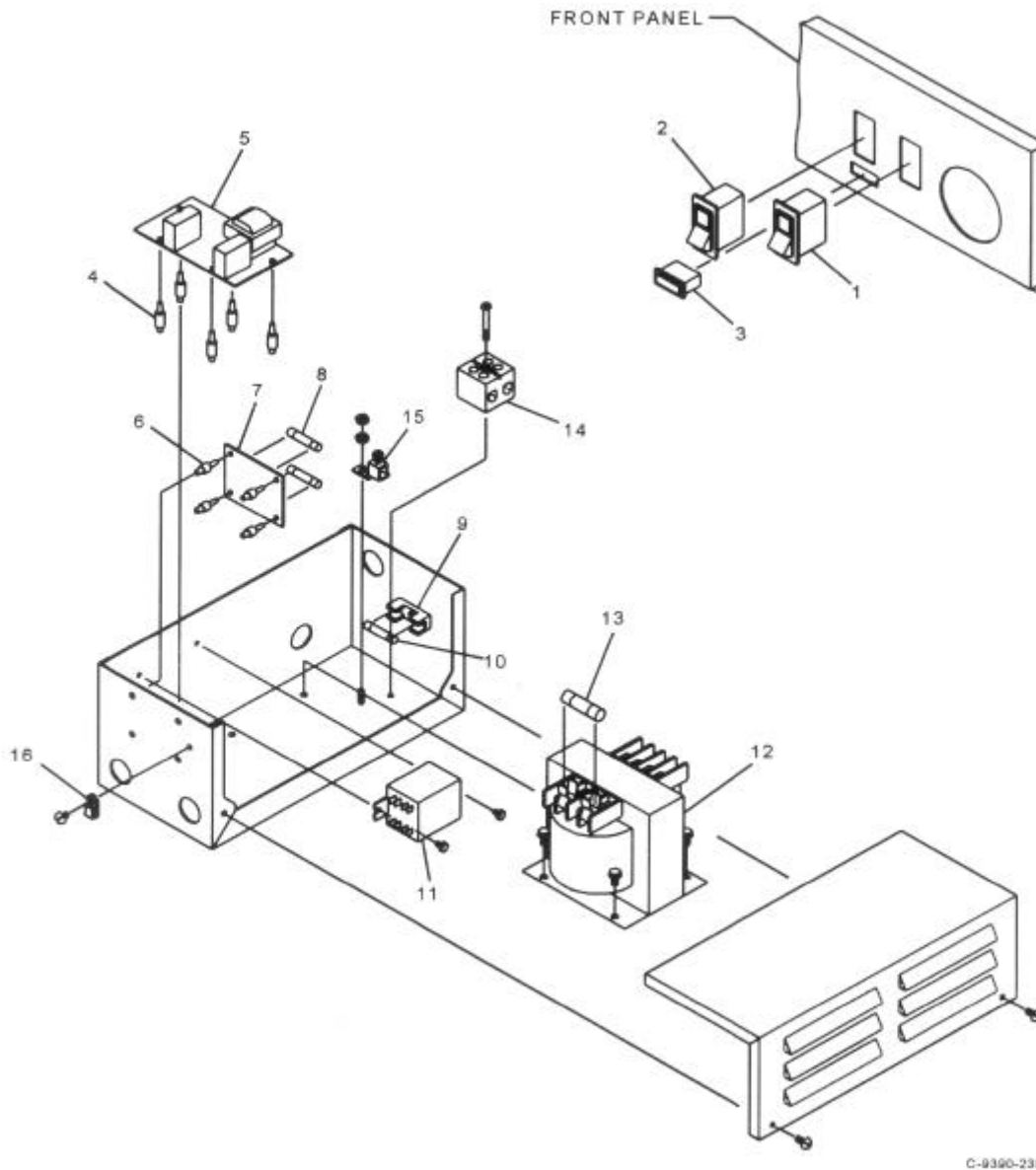

Key	Description	Part No.
1	Switch "On/off"	088876
2	Switch "Start" (Momentary)	099290
3	Indicator Light "Reset"	099289
4	Circuit Board Supports (1/2" High)	099292
5	Liquid Level Control Board	099246
6	Circuit Board Supports (1/4" High)	102228
7	Fuse Board	102220
8	Fuse, 3 Amp (Fast-blow)	077853
9	Fuse Holder	077854

Key	Description	Part No.
10	Fuse, 15 AMP (250VAC)	087946
11	Relay 24VAC Coil	074842
12	Transformer 120/208/240V Pri-24V Sec.	094164
13	Fuse, 7 AMP	096798
14	Terminal Block 2-Pole	003887
15	Ground Lug	002863
16	Tie Anchor	102231
17	Wire Harness (Not Shown)	102212

Electrical Schematic NGB/3 (Standing Pilot)

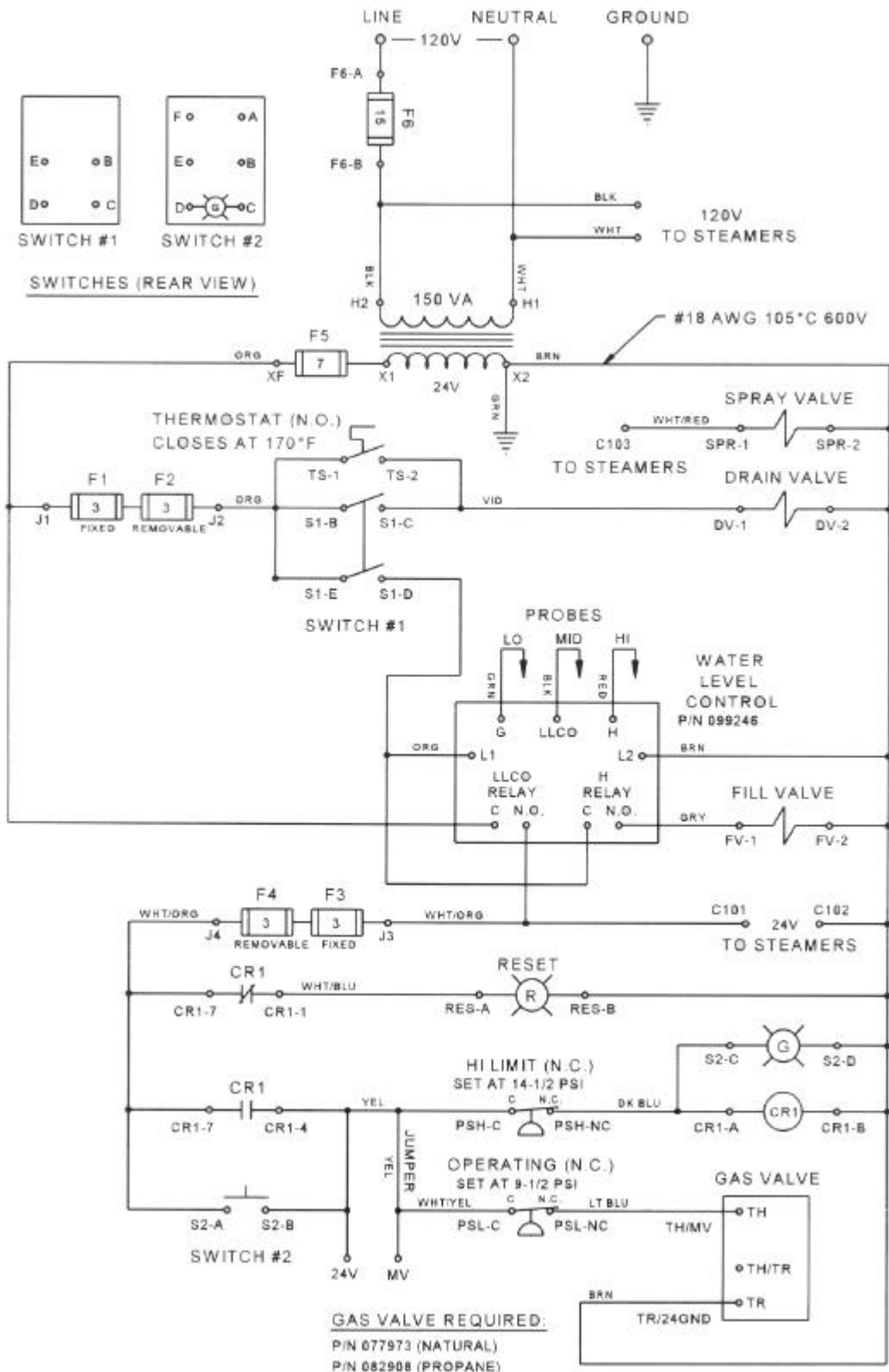

Electrical Schematic NGB/3/E (Spark Ignition)

