

Pasta Cook Kettle

- N-50P [50 Gal.]
- N-100P [100 Gal.]
- N-150P [150 Gal.]
- N-200P [200 Gal.]

General Description:

CapKold Model N-___P (specify capacity) hemispheric bottom steam jacketed pasta kettle, with integrated water wash system and overflow drains, for the rapid cooking, washing, starch removal and cooling of pasta. Pasta cook kettle may be operated manually without a control panel.

Kettle Construction:

- Hemispheric bottom jacket is designed for operation up to 90 PSI maximum pressure and built to ASME code, and National Board registered. Kettle will operate dependably between 15 PSI and 90 PSI
- 316 stainless steel interior, type 304 elsewhere
- Spiral baffle for efficient cold water jacket cooling
- Two side mounted overflow drains mounted at kettle rim and provided with stainless vertical drain piping
- Manual 3/4" cold water inlet in kettle for rapid introduction of water for product cooling and starch rinse
- Interior and exterior of kettle finished to No. 4 Sanitary Finish
- 3" manual sanitary ball valve outlet
- Stainless steel legs with adjustable stainless steel floor mounting flanges
- 3/4" swing spout water fill faucet
- Manufactured to latest sanitary standards and HACCP compliant
- Steam valve and condensate trap supplied for manual operation
- NSF listed

Control Systems:

- All kettle control valves necessary for manual kettle operation
- Factory mounted safety relief valve supplied



Options:

- Attached prepiped control valve box
- Gallon Master automatic water metering system
- Hot water to faucet
- 3" air operated drop down valve
- Flush mounted temperature sensor (Control panel required)
- Prison Package
- Kettle control panel (See Specification CKCP) requires kettle valve box

Accessories:

- Pasta Baskets
- Hoists and rail systems
(See Specifications CKH and CKPB)

Notes:

- Recommend 50-90 PSI steam for optimal cooking

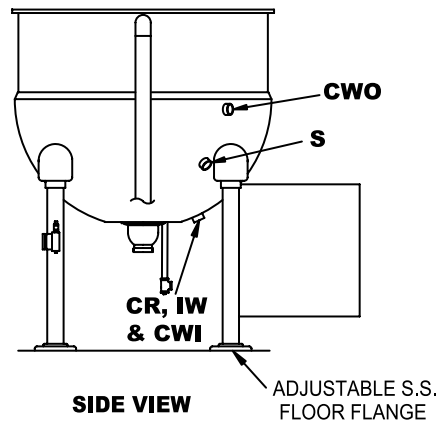
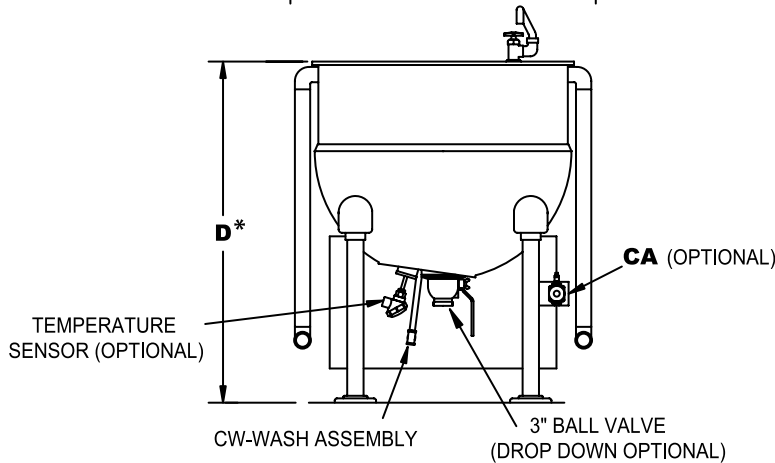
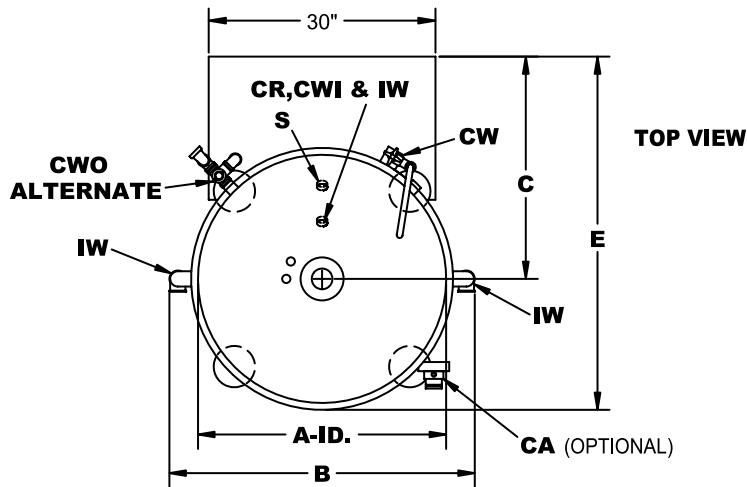

PHYSICAL DIMENSIONS

MODEL	A	B	C	D*	E	RECOMMENDED CLEARANCES		
						RIGHT	LEFT	REAR
N-50	30"	40"	35"	44.5"	51"	12"	12"	12"
N-100	36"	46"	38"	49.5"	57"	12"	12"	12"
N-150	42"	52"	41"	52.5"	63"	12"	12"	12"
N-200	48"	58"	44"	55.5"	69"	12"	12"	12"

* Additional heights available, contact factory.

UTILITY CONNECTIONS (ALL MODELS)

SYMBOL	CA (OPTIONAL)	HW	CW	COOLING	COOLING	CR	IW	S
DESCRIPTION	COMPRESSED AIR INLET	HOT POTABLE WATER INLET	COLD POTABLE WATER INLET	ICE WATER INLET	ICE WATER OUTLET	CONDENSATE RETURN	INDIRECT WASTE	STEAM INLET
CONNECTION	1/4" NPT	3/4" NPT	3/4" NPT	3/4" NPT	3/4" NPT	3/4" NPT	3/4" NPT	1" NPT

UTILITY REQUIREMENTS

MODEL	COMPRESSED AIR 90 PSI MIN.	POTABLE WATER	COOLING WATER	INDIRECT WASTE	STEAM 15-90 PSI MAX	WEIGHTS (lbs.)			
						SHIPPING	OPERATING	W / PIPING BOX OPTION	
								SHIPPING	OPERATING
N-50	1 CFM @ 80-90 PSI	10 GPM	15 GPM	1 GAL/BATCH	430 lbs/hr @ 90 PSI	550	835	750	985
N-100	1 CFM @ 80-90 PSI	10 GPM	15 GPM	2 GAL/BATCH	700 lbs/hr @ 90 PSI	625	1345	825	1500
N-150	1 CFM @ 80-90 PSI	10 GPM	15 GPM	3 GAL/BATCH	1200 lbs/hr @ 90 PSI	685	1820	885	700
N-200	1 CFM @ 80-90 PSI	10 GPM	15 GPM	3 GAL/BATCH	1400 lbs/hr @ 90 PSI	885	2400	1005	2550



Pasta Kettle Accessories

- CKPB [Pasta Basket]
- CKPBD [Pasta Basket Dolly]

Basket General Description:

CapKold Model CKPB-_____ (Specify for 50, 100, 150 or 200 gallon kettle) stainless steel cone bottom cook basket with latching slide dump gate, designed to facilitate the bulk cooking of pasta and other products into the CapKold Model N Series Pasta Kettle.

Basket Construction:

- Type 316 stainless steel construction with 3/32" perforated upper cylinder and cone bottom mesh
- Four heavy duty support lugs rest on kettle rim and protect kettle cook surface from contact and wear
- Heavy bar rim maintains round shape of basket
- Hand actuated latching bottom slide dump gate provides 12" diameter opening for rapid and complete product unloading
- Heavy duty lifting bar with yoke simplifies hoist connection and centering of load

Basket Notes:

- A minimum 1 ton electric or manually operated hoist and rail system must be provided for safe and easy kettle loading. See CKH Hoist and Rail System Spec. Sheet
- Use of Basket Dolly (See below) recommended for sanitation, safe floor movement, staging and convenient storage when not in use

Dolly General Description:

CapKold Model CKCBD-____ (Specify for 50, 100, 150 or 200 gallon kettle) stainless steel staging, loading and transfer dolly.

Dolly Construction:

- Type 304 heavy 2" tubular stainless steel construction
- Support ring height accepts basket loading lugs and maintains basket off floor and at convenient work height for loading and cleaning
- Three 4" diameter heavy duty swivel casters allow easy movement of empty basket/dolly over most floor surfaces



**CKPB
PASTA COOK BASKET**

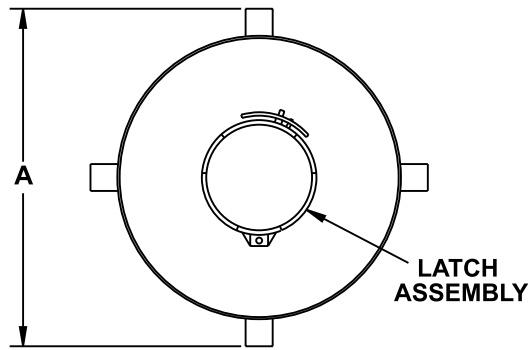

**CKPBD
TRANSPORT DOLLY**

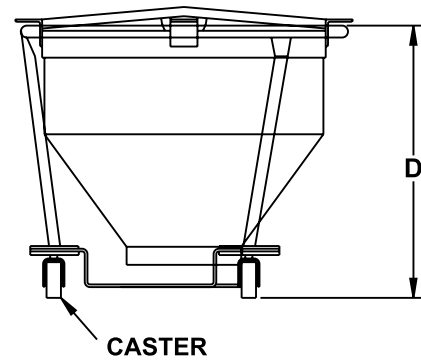
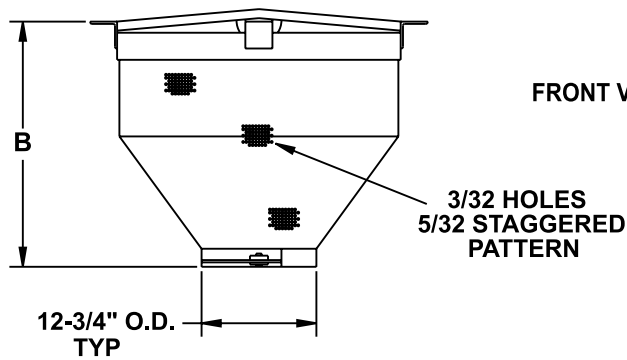
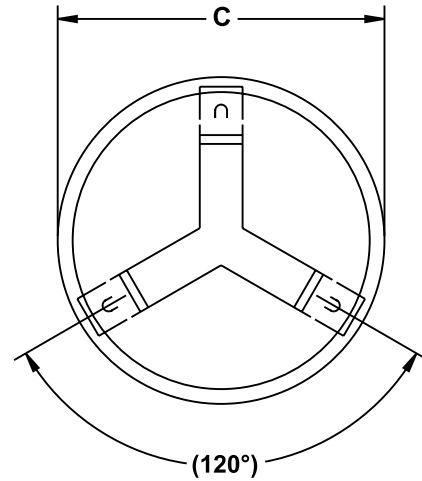

MODEL	A	B	MODEL	C	D
CKPB - 50	33-3/4"	19	CKPD - 50	34"	34"
CKPB - 100	39-3/4"	28"	CKPD - 100	40"	36-1/2"
CKPB - 150	45-3/4"	30"	CKPD - 150	46"	39"
CKPB - 200	52-1/2"	32"	CKPD - 200	52"	40-1/2"