

Cook-Chill Kettle with Tilt-Out Inclined Agitator

- INA/3-50/TO [50 Gal.]
- INA/3-100/TO [100 Gal.]
- INA/3-150/TO [150 Gal.]
- INA/3-200/TO [200 Gal.]
- INA/3-300/TO [300 Gal.]

General Description:

CapKold Model INA/3-____/TO (specify capacity) hemispheric bottom steam jacketed kettle, 2/3 jacket, with patented tilt-out inclined agitator. 100 PSI maximum jacket pressure, 3" air operated drop down product discharge valve and variable speed agitator drive.

Kettle Construction:

- Hemispherical bottom jacket is designed for operation up to 100 PSI maximum pressure and built to ASME code and National Board registered. Kettle will operate dependably at any steam-pressure between 15 PSI and 100 PSI
- Capacities are working output gallons
- Type 316 stainless steel inner hemisphere and all wetted parts. Type 304 elsewhere
- Interior and exterior of kettle finished to a No. 4 Sanitary Finish
- Spiral baffle within jacket for more efficient circulation of cooling water
- 3" air-operated, drop down, stainless steel outlet valve mounted flush to kettle bottom
- Stainless steel legs with adjustable stainless steel floor mounting flanges
- 3/4" rim-mounted swing spout water fill faucet
- Manufactured to latest sanitary standards and HACCP compliant
- NSF listed

Agitator Design:

- Tiltable inclined entry type, with easily removable agitator and breaker bar
- Water hydraulic tilt mechanism
- Replaceable nylon edge scraping blades contact entire heat exchange surface
- Variable speed gear motor drive with 7-36 RPM operating range
- Heavy duty T.E.F.C motor



Control Systems:

- Flush mounted temperature sensor at bottom of kettle
- Emergency stop switch mounted near kettle rim
- Manually controlled hydraulic agitator tilt mechanism
- Kettle-mounted control valve box pre-piped for single point utility connections

Options:

- Agitator located $\pm 45^\circ$, $\pm 90^\circ$ of rear centerline
- Remote control valve boxes
- 3" manual ball valve with 90° elbow
- Prison package

Accessories:

- 2 piece hinged cover (1/3 solid, 2/3 open grate)
- 2 piece solid cover

Notes:

- Recommend 50-75 PSI (min) steam for rapid cooking
- Larger Sizes (Consult factory for specifications)
- Single or dual kettle control panel required to operate (Consult factory for specifications)

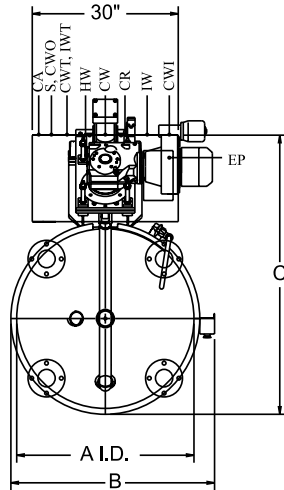

TOP VIEW

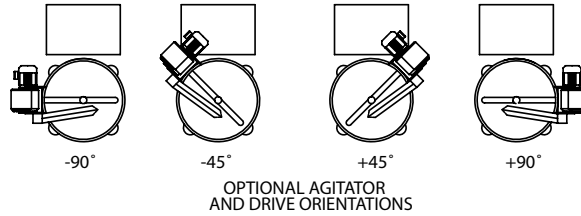
RECOMMENDED CLEARANCES

RIGHT	LEFT	REAR
12"	12"	12"
12"	12"	12"
12"	12"	12"

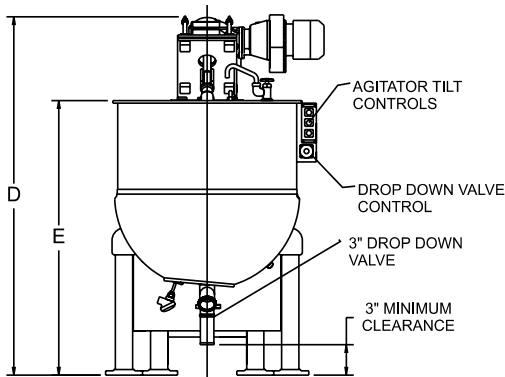

FRONT VIEW

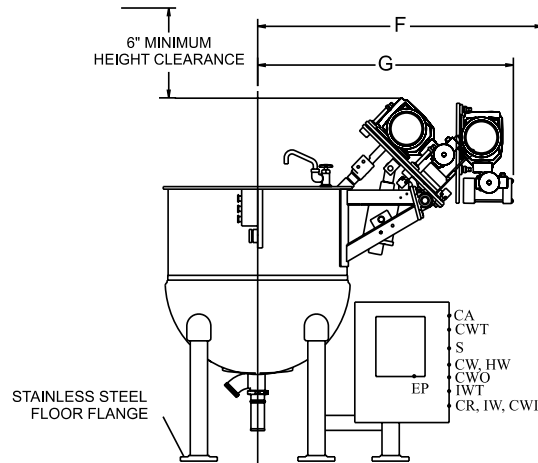

SIDE VIEW

PHYSICAL DIMENSIONS

MODEL	A	B	C	D*	E*	F	G
INA/3-100 TO	36"	41-1/4"	56"	74"	55"	57-3/4"	52"
INA/3-150 TO	42"	47-1/4"	62"	79"	62"	63-3/4"	58"
INA/3-200 TO	48"	53-1/4"	68"	84"	65-1/2"	69-3/4"	64"
INA/3-300 TO	54"	59-1/4"	74"	89"	70"	75-3/4"	70"

* OTHER HEIGHTS AVAILABLE, CONSULT FACTORY.

UTILITY CONNECTIONS (ALL MODELS)

SYMBOL	CA	CW	HW	CWI	CWO	IW	CR	S	EP
DESCRIPTION	COMPRESSED AIR INLET	COLD POTABLE WATER INLET	HOT POTABLE WATER INLET	COOLING WATER INLET	COOLING WATER OUTLET	INDIRECT WASTE	CONDENSATE RETURN	STEAM INLET	POWER SUPPLY
CONNECTION	1/4" NPT	3/4" NPT	3/4" NPT	3/4" NPT	3/4" NPT	3/4" NPT	3/4" NPT	1" NPT	3/4"

UTILITY REQUIREMENTS

MODEL	COMPRESSED AIR INLET	POTABLE WATER	COLD WATER TILT	COOLING WATER	INDIRECT WASTE	STEAM 15-100 PSI	ELECTRICAL	SHIPPING WEIGHT	OPERATING WEIGHT
INA/3-100 TO	1 CFM @ 80-90 PSI	10 GPM	60 PSI MIN.	15 GPM	10 GPM	980 LBS/HR @ 100 PSI	208/3/60 @ 7.8A 240/3/60 @ 6.8A 480/3/60 @ 3.4A	1,190 LBS	1,810 LBS
INA/3-150 TO	1 CFM @ 80-90 PSI	10 GPM	60 PSI MIN.	15 GPM	10 GPM	1335 LBS/HR @ 100 PSI	208/3/60 @ 7.8A 240/3/60 @ 6.8A 480/3/60 @ 3.4A	1,545 LBS	2,550 LBS
INA/3-200 TO	1 CFM @ 80-90 PSI	10 GPM	60 PSI MIN.	15 GPM	10 GPM	1743 LBS/HR @ 100 PSI	208/3/60 @ 11A 240/3/60 @ 9.6A 480/3/60 @ 4.8A	1,795 LBS	3,030 LBS
INA/3-300 TO	1 CFM @ 80-90 PSI	10 GPM	60 PSI MIN.	15 GPM	10 GPM	2206 LBS/HR @ 100 PSI	208/3/60 @ 11A 240/3/60 @ 9.6A 480/3/60 @ 4.8A	1,945 LBS	3,700 LBS

