

Cook-Chill Kettle with Non Tilt-Out Inclined Agitator

- INA/2-50 [50 Gal.]
- INA/2-100 [100 Gal.]
- INA/2-150 [150 Gal.]
- INA/2-200 [200 Gal.]
- INA/2-300 [300 Gal.]

General Description:

CapKold Model INA/2-___ (specify capacity) hemispheric bottom steam jacketed kettle, with patented inclined agitator, to ensure gentle yet thorough mixing of a broad range of products and enhanced suspension of ingredient solids during product transfer. 90 PSI maximum operating jacket pressure, 3" air operated drop down product discharge valve and variable speed agitator drive standard.

Kettle Construction:

- Hemispherical bottom jacket is designed for up to 90 PSI working pressure and built to ASME code and National Board registered. Kettle will operate dependably at any steam pressure between 15 PSI and 90 PSI
- Capacities are working output gallons
- Spiral baffle within jacket for more efficient circulation of cooling water
- Type 316 stainless steel inner hemisphere and all wetted parts. Type 304 elsewhere
- Interior and exterior of kettle finished to a No. 4 Sanitary Finish
- 3" air operated, drop down, stainless steel, product transfer valve mounted flush to kettle bottom
- Stainless steel legs with adjustable stainless steel floor mounting flanges
- 3/4" swing spout faucet mounted at kettle rim
- Manufactured to latest sanitary standards and HACCP compliant
- NSF listed

Agitator Design:

- Inclined, easily removable agitator and breaker bar, with removable nylon edge scraping blades which scrape entire heat exchange surface
- Variable speed gear motor drive with 7-36 rpm operating range
- Heavy duty T.E.F.C. motor



Control Systems:

- Flush mounted temperature sensor
- Emergency stop switch mounted near kettle rim
- Vacuum breaker and safety valve supplied and factory mounted
- Kettle-mounted control valve box pre-piped for single point utility connections

Options:

- Agitator located $\pm 45^\circ$, $\pm 90^\circ$ of rear centerline
- Pinned agitator for heavy, viscous products
- Remote control valve boxes
- 3" manual ball valve with 90° elbow
- Prison package

Accessories:

- 2 piece hinged cover (1/3 solid, 2/3 open grate)
- 2 piece solid cover

Note:

- Recommend 50-75 PSI (min) steam for rapid cooking
- Larger sizes (Consult factory for specifications)
- Single or dual kettle control panel required to operate (See Spec CKCP)

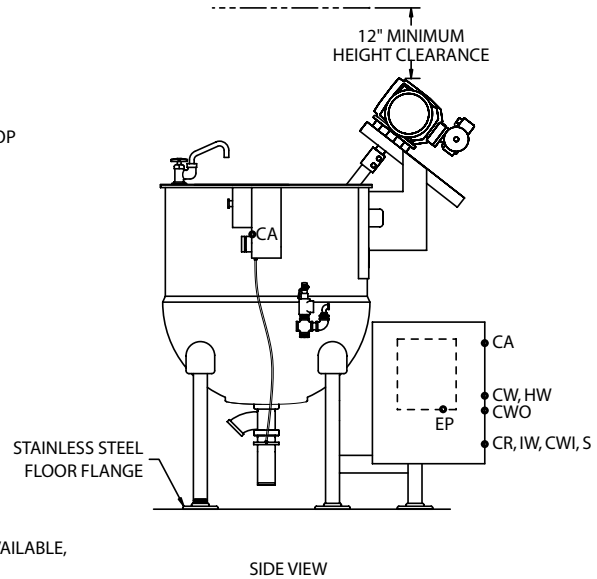
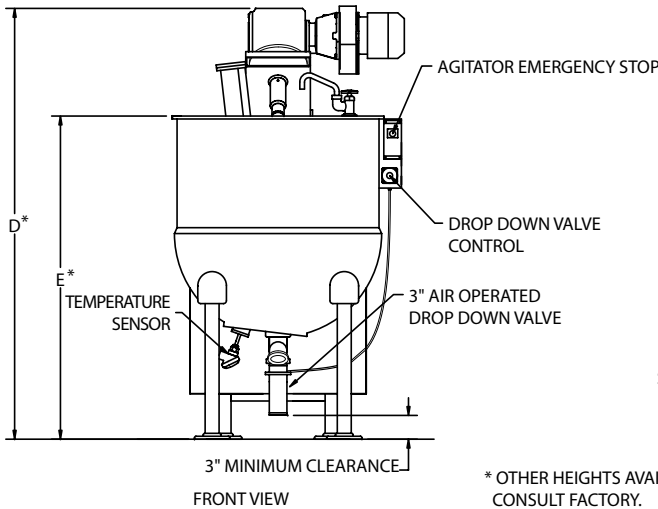
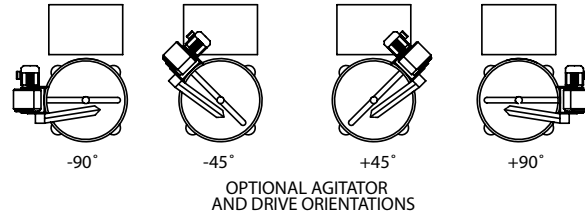
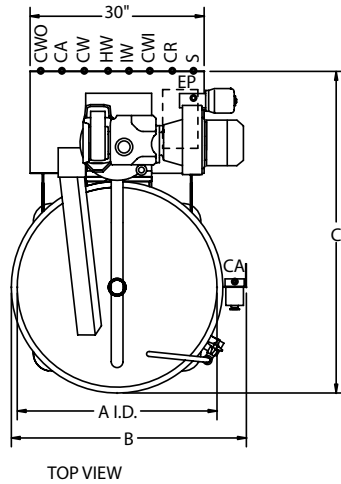

* OTHER HEIGHTS AVAILABLE, CONSULT FACTORY.

PHYSICAL DIMENSIONS

MODEL	A	B	C	D*	E*
INA/2-50	25-1/2"	31-1/2"	48-3/4"	70"	50"
INA/2-100	34"	40"	55"	74"	54"
INA/2-150	36"	42"	58"	82"	60"
INA/2-200	42"	48"	63"	84"	62"

RECOMMENDED CLEARANCES

RIGHT	LEFT	REAR
12"	12"	12"
12"	12"	12"
12"	12"	12"
12"	12"	12"

UTILITY CONNECTIONS (ALL MODELS)

* OTHER HEIGHTS AVAILABLE, CONSULT FACTORY.

SYMBOL	CA	CW	HW	CWI	CWO	IW	CR	S	EP
DESCRIPTION	COMPRESSED AIR INLET	COLD POTABLE WATER INLET	HOT POTABLE WATER INLET	COOLING WATER INLET	COOLING WATER OUTLET	INDIRECT WASTE	CONDENSATE RETURN	STEAM INLET	POWER SUPPLY
CONNECTION	1/4" NPT	3/4" NPT	3/4" NPT	3/4" NPT	3/4" NPT	3/4" NPT	3/4" NPT	1" NPT	3/4"

UTILITY REQUIREMENTS

MODEL	COMPRESSED AIR INLET	POTABLE WATER	COLD WATER TILT	COOLING WATER	INDIRECT WASTE	STEAM 15-90 PSI	ELECTRICAL	SHIPPING WEIGHT	OPERATING WEIGHT
INA/2-50	1 CFM @ 80-90 PSI	10 GPM	40 PSI MIN.	15 GPM	10 GPM	430 LBS/HR @ 90 PSI	208/3/60 @ 6A 240/3/60 @ 5.2A 480/3/60 @ 2.6A	950 LBS	1,225 LBS
INA/2-100	1 CFM @ 80-90 PSI	10 GPM	40 PSI MIN.	15 GPM	10 GPM	700 LBS/HR @ 90 PSI	208/3/60 @ 7.8A 240/3/60 @ 6.8A 480/3/60 @ 3.4A	1,190 LBS	1,810 LBS
INA/2-150	1 CFM @ 80-90 PSI	10 GPM	40 PSI MIN.	15 GPM	10 GPM	900 LBS/HR @ 90 PSI	208/3/60 @ 11A 240/3/60 @ 9.6A 480/3/60 @ 4.8A	1,545 LBS	2,550 LBS
INA/2-200	1 CFM @ 80-90 PSI	10 GPM	40 PSI MIN.	15 GPM	10 GPM	1200 LBS/HR @ 90 PSI	208/3/60 @ 11A 240/3/60 @ 9.6A 480/3/60 @ 4.8A	1,795 LBS	3,030 LBS

