



HyPerSteam Pressureless Steamer model HY-6SG

Description

Steamer shall be a Groen HyPLUS™ Model HY-6SG stainless steel twin cavity, 6-pan pressureless steamer, with cabinet-mounted 200,000 BTU gas steam boiler, per Bulletin 76Ba as follows:

Construction

Steamer cavities and cabinet base shall be all stainless steel construction. Steamer unit shall have a unitized body, with removable lift-off panels providing access to internal components. Steamer doors are all stainless steel with strong continuous hinge and are field-reversible for left or right swing. Doors shall be insulated and provided with a one-piece, replaceable seal. Easy-open handle and latch shall provide positive lock and seal when door is pushed or slammed shut.

Hidden magnetic door switch cuts power to blower and steam flow to that cavity, when the door is opened. Pan support racks shall be electro-polished stainless steel and removable for easy cleaning. Wide drip sink with condensate drain is positioned under cavity doors.

24" wide cabinet base shall have stainless steel frame with all stainless steel top deck, removable lift-off panels standard. Front and rear legs shall have adjustable bullet feet. Flanged feet are an available option.

Finish

Cabinet exterior, including doors, shall be finished to a #3 uniform finish. Cavity interiors are electro-polished stainless steel. Control panel face plates shall be smudge-resistant polyester film.

ASME Code, AGA & UL Listings

Cabinet-mounted boiler shall be ASME Code-constructed and National Board registered for operation up to 15 PSI. Gas boiler shall be design-certified by the American Gas Association and steamer unit is UL-listed.

Sanitation

Unit shall be designed and manufactured to be NSF-listed, meeting regulatory known health department and sanitation codes.

Controls

Steamer Cavity controls shall be mounted on the front panel for easy replacement or repair and include a separate ON-OFF 60-minute timer control with a constant steam setting, for each cavity. Gas boiler shall be provided with a gas control valve, power-ON switch, RESET light, start switch, low water sensor, pop safety valve, water level sight glass on front panel and outside cabinet-mounted pressure gauge.

Performance Features

Unit will shut off if water level is low or unit builds too much pressure. When power switch is turned "OFF," the boiler automatically drains to reduce sediment build-up, after water has cooled to 170°F.

Each steamer cavity shall have a powerful side-mounted blower, which increases steam velocity and provides efficient steam distribution throughout cavity and between loaded pans. Boiler delivers approximately 20,000 BTU/hr input per 2 1/2" deep steam pan capacity. Unit comes



standard with electronic ignition.

Cabinet Base Steam Source

Unit shall have twin gas-heated, cabinet-mounted pressure boiler to provide atmospheric steam to each chamber at a temperature of approximately 212° (F). The 200,000 BTU generator delivers 3.7 boiler horsepower. Unit comes standard with electronic ignition.

Pan Capacity

Pan Size	Per Cavity	Total
12 x 20 x 1"	6	12
12 x 20 x 2 1/2"	3	6
12 x 20 x 4"	2	4

Options/Accessories

- Flanged Feet
- Independent water supply for condensate spray

Installation

Unit requires gas service via 1/2" NPT pipe or approved equivalent. Specify type of gas. Unit requires 1/2" NPT cold water supply line, 1 1/4" NPT free venting drain; and 115 volt, single phase, 60 cycle 15 AMP electric service, 4 AMP maximum load.

Steam Source for Adjacent Equipment

A 1/2" NPT power take-off valve shall be standard. To ensure proper performance boiler must be properly sized to meet boiler horsepower requirements of steamer cavities and additional equipment. Appropriate steam traps and piping must be professionally installed.

Water Supply Requirements

All water boiler systems are subject to contamination and failure due to mineral content found in most water supplies. To minimize service problems, a water treatment (softening) system is recommended when water quality is found to exceed limits stated below and in operator manual. Recommended MINIMUM water quality standards are: Total dissolved solids (TDS) content should not exceed 30 parts per million; and the pH should be 7.0 or higher.

Origin of Manufacture

Steamer shall be designed and manufactured in the United States.

**6-Pan Capacity
Stainless Steel
Pressureless
Steamer**

**With Gas
Pressure Boiler
In Cabinet Base**

Short Form

Unit shall be a Groen HyperPLUS™ pressureless steamer Model HY-6SG with gas-heated pressure boiler mounted in 24" wide cabinet base. All stainless steel construction with two independent steamer chambers, each with powerful blower to circulate steam within cavity and individual 60 minute timer, with constant steam setting. Insulated, field-reversible doors have easy open latch and hidden magnetic door switch. Drip sink with condensate drain is provided under cavity doors. Three 2 1/2" deep pan capacity per chamber. Cabinet base has stainless steel frame, all stainless steel exterior with removable lift-off panels and adjustable bullet feet. Generator ASME code-constructed for 15 PSI maximum, with 200,000 BTU firing rate, 120,000 BTU output and 3.7 boiler horsepower. Power takeoff to divert steam to adjacent equipment is standard. AGA design-certified and standard with automatic boiler drain and electronic ignition. See back for water, drain, electric and gas connections. Made in USA.



Applications

- Pasta
- Rice
- Vegetables (Fresh & Frozen)
- Seafood (Fresh & Frozen)
- Poultry
- Potatoes
- Eggs
- Meats
- Reheat Cook-Chill & Prepared Foods

SERVICE CONNECTIONS:

1. DRAIN CONNECTION: 1-1/4 NPT (INCLUDING AUTOMATIC & MANUAL STEAM GENERATORS, STEAMERS, & CONDENSATE SPRAY)
2. COLD WATER SUPPLY: 1/2 NPT (FOR BOILER & CONDENSATE SPRAY)
3. OPTION: SEPARATE CONDENSATE SPRAY 3/8 NPT (ADD KIT #MS102210)
4. ELECTRICAL CONNECTION: 7/8" DIA. HOLE (REF. 1/2" CONDUIT KNOCK-OUT)
5. GAS CONNECTION: 1/2 NPT
6. STEAM POWER TAKE-OFF: 1/2 NPT
7. MINIMUM CLEARANCE REQUIRED.
8. DIMENSIONS IN BRACKETS () ARE MM.

	NATURAL GAS	PROPANE GAS
GAS OPERATING PRESSURE	3.5" W.C.	10.0" W.C.
RECOMMENDED INCOMING GAS FEED RATE	5"W.C. MIN 14"W.C. MAX	11"W.C. MIN 14"W.C. MAX
MAX. INPUT-BTU/HR	200,000	
MAX. OUTPUT-BTU/HR	120,000	
STEAM GENERATOR HORSEPOWER: 3.7		

*W.C.=WATER COLUMN

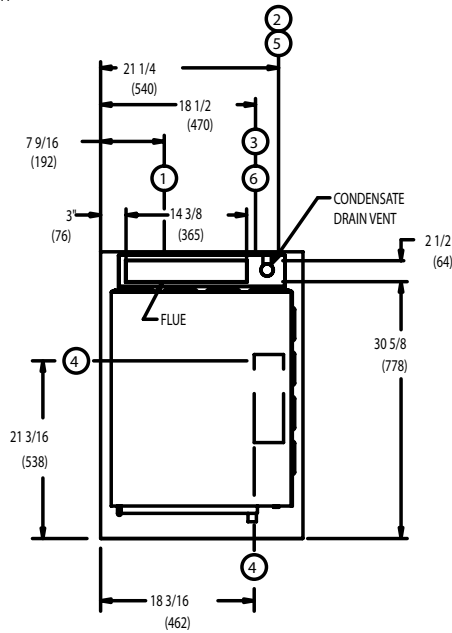

TOP VIEW

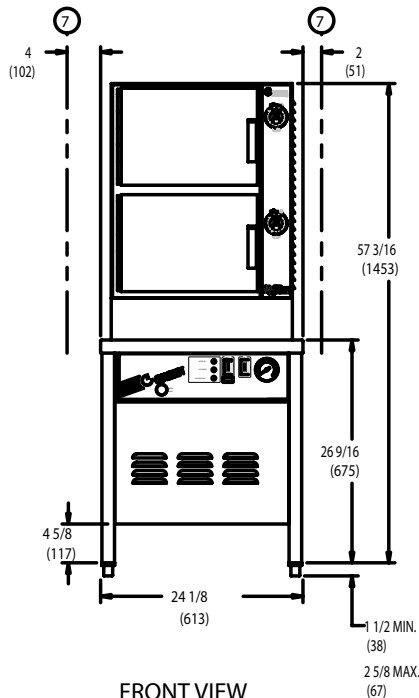
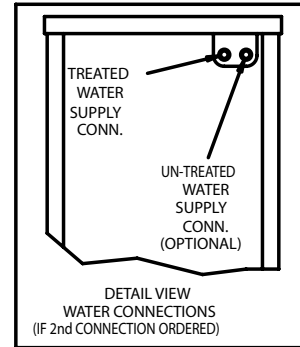

FRONT VIEW

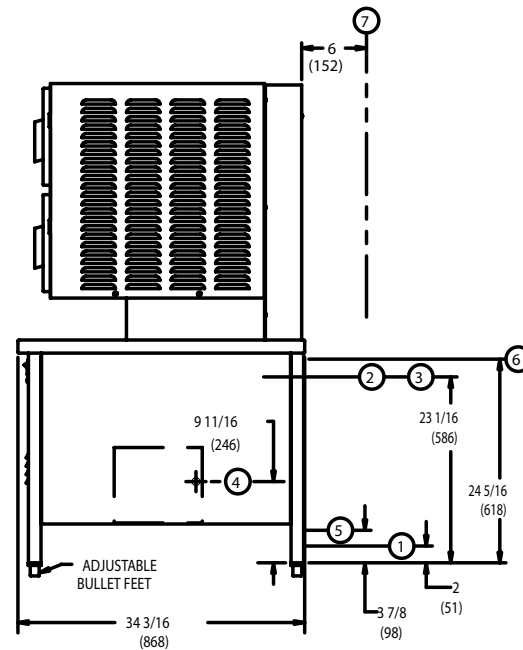

RIGHT SIDE VIEW

