



HyPerSteam Pressureless Steamer model HY-6SE

Description

Steamer shall be a Groen HyPLUS Model HY-6SE stainless steel twin cavity 6 pan pressureless steamer, with cabinet mounted (specify 24, 36, or 48 KW) electric steam boiler, per Bulletin 76Aa and as follows:

Construction

Steamer cavities and cabinet base shall be all stainless steel construction. Steamer unit shall have a unitized body, with removable right side panel providing access to internal components. Steamer doors are all stainless steel with strong continuous hinge and are field reversible for left or right swing. Doors shall be insulated and provided with a one piece, replaceable seal. Easy open handle and latch shall provide positive lock and seal when door is pushed or slammed shut.

Hidden magnetic door switch cuts power to blower and steam flow to that cavity, when the door is opened. Pan support racks shall be polished stainless steel and removable for easy cleaning. Wide drip sink with condensate drain is positioned under cavity doors.

24" wide cabinet base shall have stainless steel frame with all stainless steel top deck, with hinged front access panel and removable side and rear panels standard. Front and rear legs shall have adjustable bullet feet.

Finish

Cabinet exterior including doors shall be finished to a #3 uniform finish. Cavity interiors are polished stainless steel. Control panel face plates shall be smudge resistant polyester film, ensuring maximum ease in cleaning and maintaining a brilliant finish.

ASME Code & UL Listing

Cabinet mounted boiler shall be A.S.M.E. Code constructed and National Board registered for operation up to 15 PSI. Steamer unit and cabinet mounted boiler shall be U.L. listed.

Sanitation

Unit shall be designed and constructed to meet NSF and known health department and sanitation codes and be NSF listed.

Controls

Steamer cavity controls shall be mounted on the front panel for easy replacement or repair and will include separate ON-OFF/60 minute timer control with constant steam setting, for each cavity. Electric boiler shall be provided with a power-ON switch, RESET light, start switch, low water sensor, pop safety valve, water level sight glass and outside cabinet mounted pressure gauge.

Performance Features

Unit will shut off if water level is low or unit builds too much pressure. When power switch is turned "off" the boiler automatically drains to reduce sediment build-up, after water has cooled to 170°F. Each steamer cavity shall have a powerful side mounted blower, which increases steam velocity and provides efficient steam distribution throughout cavity and between loaded pans.

Cabinet Base Steam Source

Unit shall have an electric heated cabinet mounted pres-



sure boiler to provide atmospheric steam to each chamber at a temperature of approximately 212°F. The 24KW model delivers 2.2 boiler horsepower, the 36KW model delivers 3.5 boiler horsepower and the 48 KW model delivers 4.7 boiler horsepower.

Pan Capacity

Pan Size	Per Cavity	Total
12 x 20 x 1"	6	12
12 x 20 x 2 1/2"	3	6
12 x 20 x 4"	2	4

Installation

Specify 208, 240 or 480 Volt, 3 phase, 60 cycle electrical service. Unit requires 1/2" NPT cold water supply line and 1 1/4" NPT free venting drain.

Steam Source For Adjacent Equipment

A 1/2" NPT power take-off valve shall be standard. To ensure proper performance, boiler must be properly sized to meet boiler horsepower requirements of steamer cavities AND additional equipment. Appropriate steam traps and piping must be professionally installed.

Water Supply Requirements

All water boiler systems are subject to contamination and failure due to mineral content found in most water supplies. To minimize service problems, a water treatment (softening) system is recommended when water quality is found to exceed limits stated below and in operator manual.

Recommended MINIMUM water quality standards are: Total dissolved solids (TDS) content should not exceed 30 parts per million; and the water pH should be 7.0 to 9.0.

Options/Accessories

- Flanged mounting feet
- Second water connection for condensate spray

Origin of Manufacture

Steamer shall be designed and manufactured in the United States.

**6 Pan Capacity
Stainless Steel
Pressureless Steamer**

**With Electric
Pressure Boiler
In Cabinet Base**

Short Form

Unit shall be a Groen HyPLUS pressureless steamer Model HY-6SE, with electric heated pressure boiler mounted in 24" wide cabinet base, per Bulletin 76Aa. All stainless steel construction, with two independent steamer chambers each with powerful blower to circulate steam within cavity and individual 60 minute timer with constant steam setting. Doors are insulated, field reversible with easy open latch and hidden magnetic door switch. Drip sink with condensate drain is provided under cavity doors. Three (2 1/2" deep) pan capacity per chamber. Cabinet base has stainless steel frame, all stainless steel exterior with hinged front access panel and adjustable bullet feet. Boiler is ASME code constructed for 15 PSI maximum, with choice of 24, 36 or 48KW power input. Power takeoff to divert steam to adjacent equipment is standard. UL listed, unit comes standard with automatic boiler drain. See other side for water, drain and electric connections required. Made in USA.



Applications

- Pasta
- Rice
- Vegetables (Fresh & Frozen)
- Seafood (Fresh & Frozen)
- Poultry
- Potatoes
- Eggs
- Meats
- Reheat Cook-Chill & Prepared Foods

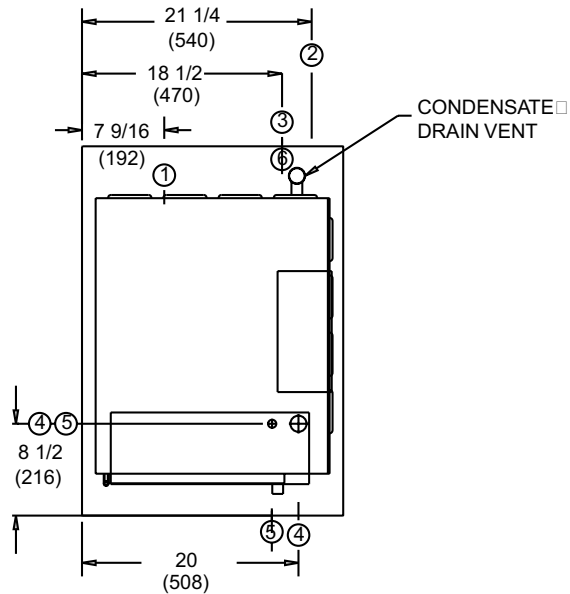

	MAXIMUM HEATER ELEMENT CURRENT*		
	208V	240V	480V
24KW	67A	58A	29A
36KW	100A	87A	44A
48KW	134A	116A	58A

* AMPS (EACH LINE), 3 PHASE

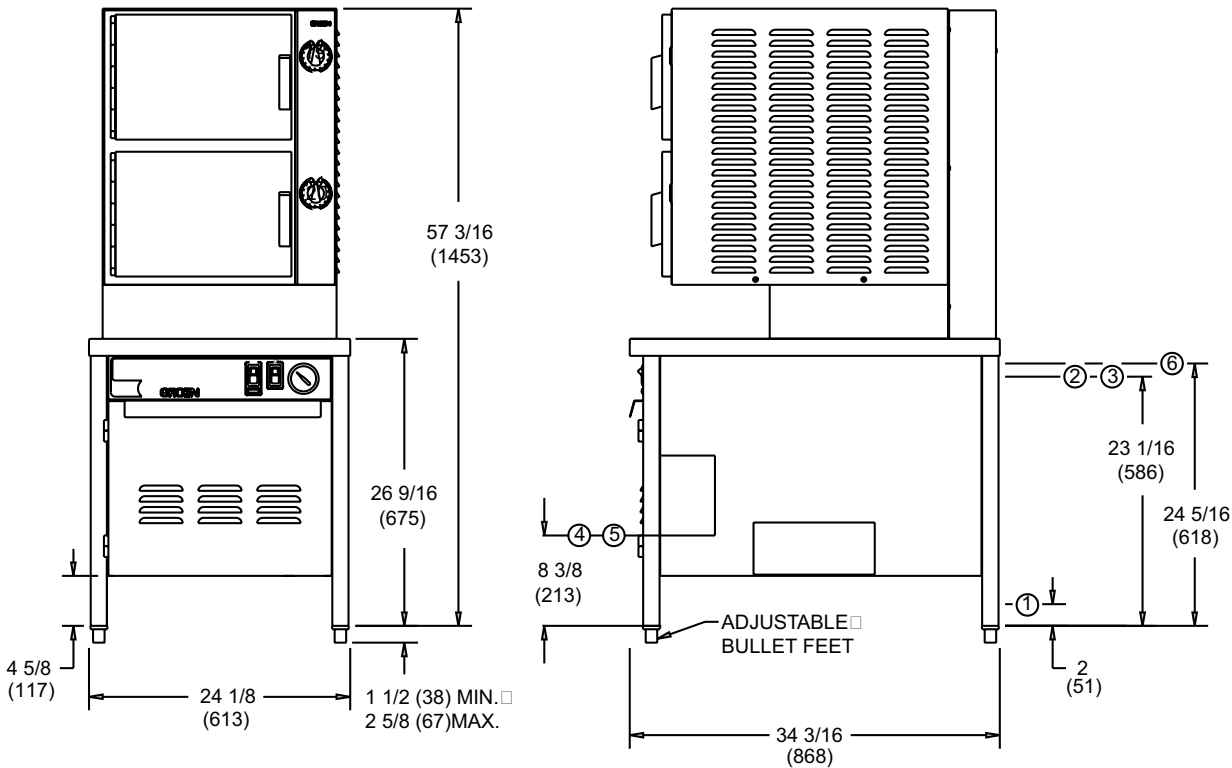
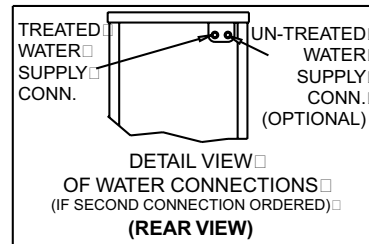
DIMENSIONS: INCHES (MILLIMETERS)
SERVICE CONNECTIONS:

- ① DRAIN CONNECTION: 1 1/4" NPT (INCLUDES AUTOMATIC & MANUAL BOILER, STEAMERS, & CONDENSATE SPRAY)
- ② COLD WATER SUPPLY: 1/2" NPT (FOR BOILER & CONDENSATE SPRAY)
- ③ OPTION: SEPARATE CONDENSATE SPRAY 3/8" NPT (ADD KIT #MS102210)
- ④ MAIN ELECTRICAL CONNECTION (ALL UNITS): 1 31/32" DIA. HOLE (REF. 1 1/2" CONDUIT KNOCK-OUT)
- ⑤ AUX. ELECTRICAL CONNECTION (208V / 240V 48KW ONLY): 1 3/32" DIA. HOLE (REF. 3/4" CONDUIT KNOCK-OUT)
- ⑥ STEAM POWER TAKE-OFF: 1/2" NPT

