



# HyPerSteam Pressureless Steamer model HY-6G

## Description

Steamer shall be a Groen Model HY-6G stainless steel pressureless steamer with twin atmospheric 45,000 BTU/hr gas steam generators, for total of 90,000 BTU maximum, per Bulletin 140797 as follows:

## Construction

Steamer cavities and cabinet base shall be all stainless steel construction with removable right side panel providing access to internal components. Steamer doors are all stainless steel, with strong continuous hinge and is field-reversible for left or right-swing. Doors shall be insulated and provided with a one piece, replaceable seal. Easy-open handle and latch shall provide positive lock and seal when door is pushed or slammed shut.

Hidden magnetic door switch cuts power to blower and cuts power to generator when the door is opened. Pan support racks shall be polished stainless steel and removable for easy cleaning. Wide drip sink with condensate drain is positioned under cavity doors.

21 5/8" wide cabinet base shall have stainless steel frame with removable front, side and back panels standard. Cabinet base shall be provided with 6" legs with adjustable bullet feet.

## Finish

Cabinet exterior including door shall be finished to a #3 uniform finish. Cavity interiors are polished stainless steel. Control panel face plates shall be smudge resistant polyester film, ensuring maximum ease in cleaning and maintaining an attractive appearance.

## C.S.A. Design Certification

Steamer shall be C.S.A. (formerly A.G.A.) design-certified to ANSI Z83.11.

## Sanitation

Unit shall be designed and manufactured to meet NSF codes and be NSF-listed. Unit shall allow operator to delime both steam generators through access ports on top of unit without tools or service call. Push button auto-DELIME is standard.

## Controls

Steamer cavity controls shall include an ON-OFF power touch pad; 60 minute mechanical timer, with continuous steam setting; and READY light which indicates when cavity is ready for steaming. Auto-DELIME button initiates deliming cycle.

## Performance Features

Each steamer cavity shall have a powerful side-mounted blower, which increases steam velocity and provides efficient steam distribution throughout cavity and between loaded pans. Steam generators deliver approximately 15,000 BTUs/hour input per 2 1/2" deep steam pan.

Heat up time to READY shall be 8-10 minutes, under normal conditions. Cavities are kept warm and ready for instant steam between loads. No cavity warm up required, after READY light comes on.

Model HY-6G Shown



DELIME indicator light warns operator of need to delime generator. Unit will shut off if water level is low. When power is turned off, unit automatically blows down the steam generator, to reduce sediment build-up.

## Cabinet Base Steam Source

Unit shall have twin gas heated cabinet mounted steam generators to provide atmospheric steam to the chambers at a temperature of approximately 212° F. Each steam generator has an electric water sensor, a 45,000 BTU/hr firing rate. Unit comes standard with standing pilot with electronic ignition system.

## Pan Capacity

Pan Size	Per Cavity	Total
12 x 20 x 1"	6	12
12 x 20 x 2 1/2"	3	6
12 x 20 x 4"	2	4

## Installation

Unit requires gas service (specify natural or propane) via 1/2" NPT pipe or approved equivalent. Unit requires 2 3/4" NH cold water supply lines; and 1 1/2" free venting drain; and 115 volt single phase, 4 AMP electric service. A second cold water connection is provided for the spray condenser.

## Water Supply Requirements

To minimize service problems a PureSteam water treatment (softening) system is recommended when water quality is found to exceed limits stated below and in operator manual.

Recommended MINIMUM water quality standards are: Total dissolved solids (TDS) content should have a value of 30 to 40 parts per million, and the water pH should be 7.0 to 9.0

## Origin of Manufacture

Steamer shall be designed and manufactured in the United States.

**6-Pan Capacity  
Stainless Steel  
Pressureless  
Steamer**

**With Twin Gas  
Atmospheric  
Steam Generators In  
Cabinet Base**

## Short Form

Unit shall be a Groen HyPerSteam pressureless steamer Model HY-6G with twin, independent electric heated steam generators mounted in 21 5/8" wide cabinet base, per Bulletin 140797. All stainless steel construction with two steam cavities, each powered by its own independent atmospheric steam generator with powerful blower to circulate steam within cavity and separate operating controls, including: 60 minute electromechanical timer with constant steam setting, ready light and DELIME cycle button to initiate deliming. Doors are field reversible, with easy open latch and hidden magnetic door switch, and wide condensate sink with drain is provided under cavity doors. The unit shall have twin atmospheric 45,000 BTU/hr gas steam generators. Unit shall come up to steam in 8-10 minutes or less from a cold start, and provide warm cavity instant steam capability. C.S.A. and N.S.F. listed. See other side for required gas, water and drain connections. Made in USA.



## Applications

- Pasta
- Rice
- Vegetables (Fresh & Frozen)
- Seafood (Fresh & Frozen)
- Poultry
- Potatoes
- Eggs
- Meats
- Reheat Cook-Chill & Prepared Foods

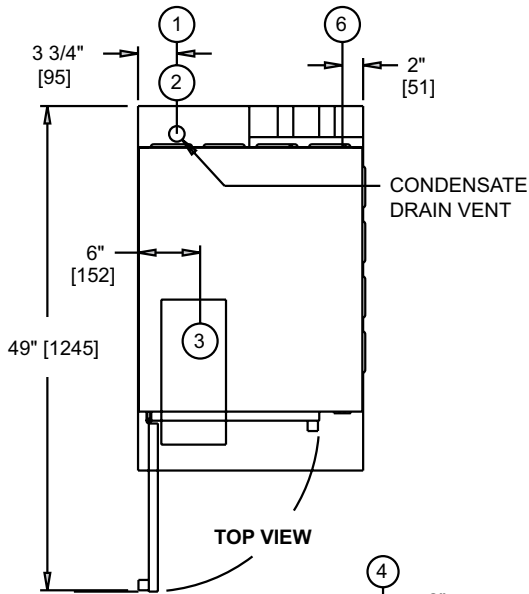
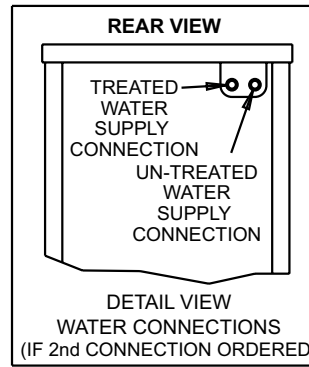

	NATURAL GAS	PROPANE GAS
GAS OPERATING PRESSURE	3.7" W.C.	10.5" W.C.
MAX.INPUT BTU/HR	90,000	90,000
RECOMMENDED INCOMING GAS FEED RATE	5" W.C. MIN	12" W.C. MIN
	14" W.C. MAX	14" W.C. MAX

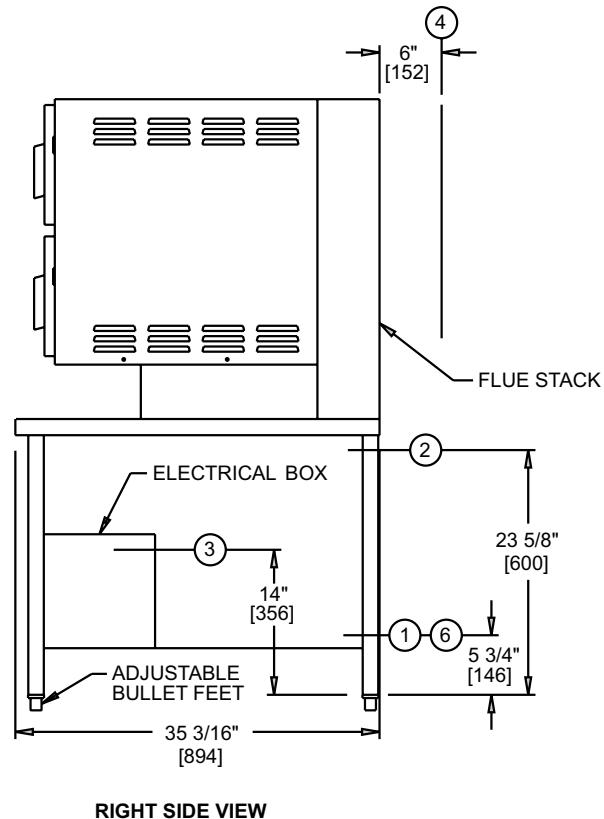
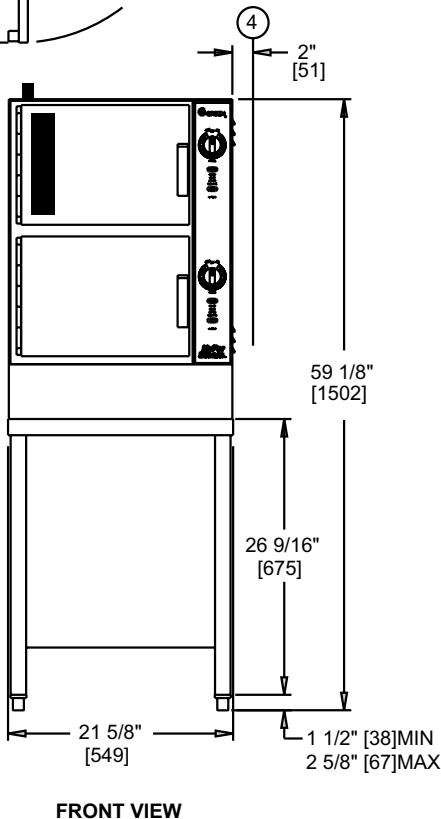
**SERVICE CONNECTIONS AND NOTES:**

1. DRAIN CONNECTION 1 1/2" TUBE (DRAIN FREE VENTING)
2. COLD WATER SUPPLY AT 30 TO 60 PSIG WITH A FLOW RATE OF 1.50 - 3.00 GPM AND WITH A 3/4" NH CONNECTION.
3. ELECTRICAL CONNECTION 1" CONDUIT. REQUIREMENTS: 108-126 V @ 2.5 AMPS, 60Hz OR 230 V @ 2 AMPS, 50/60 HZ
4. MINIMUM CLEARANCE REQUIRED: REAR = 6" [152], LEFT SIDE = 0" [0], RIGHT SIDE = 2" [51]
5. DIMENSIONS IN BRACKETS [ ] ARE MM
6. GAS CONNECTION: 1/2" NPT

