

IMPORTANT INFORMATION

KEEP FOR OPERATOR

IMPORTANT INFORMATION

OPERATOR MANUAL

Part Number 148668 Rev. C

OM-HY-6E

DOMESTIC

Model: HY-6E
HyPerSteam™
Atmospheric Convection
Steamer (Re-Designed)

Self-Contained
Electric Heated
Capacity: 6 Steamer Pans
(12" x 20" x 2 1/2")



THIS MANUAL MUST BE RETAINED FOR FUTURE REFERENCE. READ, UNDERSTAND AND FOLLOW THE INSTRUCTIONS AND WARNINGS CONTAINED IN THIS MANUAL.

FOR YOUR SAFETY
DO NOT STORE OR USE GASOLINE OR OTHER FLAMMABLE VAPORS AND LIQUIDS IN THE VICINITY OF THIS OR ANY OTHER APPLIANCE.



Packaging - Processing
Bid on Equipment
1-847-683-7720
www.bid-on-equipment.com

IMPORTANT — READ FIRST — IMPORTANT

- WARNING:** THE UNIT MUST BE INSTALLED BY PERSONNEL QUALIFIED TO WORK WITH ELECTRICITY AND PLUMBING. IMPROPER INSTALLATION CAN CAUSE INJURY TO PERSONNEL AND/OR DAMAGE TO THE EQUIPMENT. THE UNIT MUST BE INSTALLED IN ACCORDANCE WITH APPLICABLE CODES.
- NOTICE:** DO NOT BLOCK THE RIGHT SIDE VENTS, AND DO NOT INSTALL WITHIN 12 INCHES OF A HEAT SOURCE SUCH AS A BRAISING PAN, DEEP FRYER, CHAR BROILER OR KETTLE.
- NOTICE:** LEVEL THE UNIT FRONT TO BACK, OR PITCH IT SLIGHTLY TO THE REAR, TO AVOID DRAINAGE PROBLEMS.
- CAUTION:** DO NOT LOCATE THE CABINET DIRECTLY OVER A FLOOR DRAIN OR SINK. HUMIDITY OR WATER FROM A DRAIN WILL DAMAGE ELECTRICAL PARTS OF A UNIT.
- WARNING:** TO AVOID DAMAGE OR INJURY, FOLLOW THE WIRING DIAGRAM EXACTLY WHEN CONNECTING A UNIT.
- CAUTION:** DO NOT USE PLASTIC PIPE. DRAIN MUST BE RATED FOR BOILING WATER.
- WARNING:** DO NOT CONNECT THE DRAIN DIRECTLY TO A BUILDING DRAIN.
- WARNING:** BLOCKING THE STEAM GENERATOR OR CAVITY DRAIN SCREEN MAY BE HAZARDOUS.
- IMPORTANT:** IMPROPER DRAIN CONNECTION WILL VOID WARRANTY.
- WARNING:** WHEN YOU OPEN THE DOOR, STAY AWAY FROM STEAM COMING OUT OF THE UNIT. STEAM CAN CAUSE BURNS.
- WARNING:** BEFORE CLEANING THE OUTSIDE OF THE STEAMER, DISCONNECT THE ELECTRIC POWER SUPPLY. KEEP WATER AND CLEANING SOLUTIONS OUT OF CONTROLS AND ELECTRICAL COMPONENTS. NEVER HOSE OR STEAM CLEAN ANY PART OF THE UNIT.
- WARNING:** ALLOW COOKING CHAMBERS TO COOL BEFORE CLEANING.
- WARNING:** CAREFULLY READ THE WARNINGS AND FOLLOW THE DIRECTIONS ON THE LABEL OF EACH CLEANING AGENT. USE SAFETY GLASSES AND RUBBER GLOVES AS RECOMMENDED BY DELIMING AGENT MANUFACTURER.
- WARNING:** DO NOT MIX DE-LIMING AGENTS (ACID) AND DE-GREASERS (ALKALI) IN THE STEAM GENERATOR OR ON THE COOKING CHAMBER WALLS.
- WARNING:** DO NOT PUT HANDS OR TOOLS INTO THE COOKING CHAMBER UNTIL THE FAN HAS STOPPED TURNING.
- WARNING:** DO NOT OPERATE THE UNIT UNLESS THE REMOVABLE RIGHT SIDE PANELS HAVE BEEN RETURNED TO THEIR PROPER LOCATIONS.
- NOTICE:** DO NOT USE A CLEANING OR DE-LIMING AGENT THAT CONTAINS ANY SULFAMIC ACID OR ANY CHLORIDE, INCLUDING HYDROCHLORIC ACID. IF THE CHLORIDE CONTENT OF ANY PRODUCT IS UNCLEAR, CONSULT THE MANUFACTURER.
- NOTICE:** USE NO DE-GREASER THAT CONTAINS POTASSIUM HYDROXIDE OR SODIUM HYDROXIDE OR THAT IS ALKALINE.
- WARNING:** USE OF ANY REPLACEMENT PARTS OTHER THAN THOSE SUPPLIED BY GROEN OR THEIR AUTHORIZED DISTRIBUTOR voids all warranties and can cause bodily injury to the operator and damage the equipment. Service performed by other than factory-authorized personnel will void all warranties.
- WARNING:** HIGH VOLTAGE EXISTS INSIDE CONTROL COMPARTMENTS. DISCONNECT FROM BRANCH BEFORE SERVICING. FAILURE TO DO SO CAN RESULT IN SERIOUS INJURY OR DEATH.

Table of Contents

OPERATOR WARNINGS	2
EQUIPMENT DESCRIPTION	4
WATER CONDITIONING/REQUIREMENTS	4
INSPECTION AND UNPACKING	6
INSTALLATION AND START-UP INSTRUCTIONS	7
OPERATING INSTRUCTIONS	10
CLEANING PROCEDURES	12
MAINTENANCE AND TROUBLESHOOTING	14
SERVICE LOG	15
REFERENCES	16
WARRANTY PROTECTION	17

Equipment Description

Your Groen HY-6E HyPerSteam Convection Steamer is designed to give years of service. It has two stainless steel cavities (cooking chambers) which are served by twin, independent atmospheric steam generators which are electrically-heated. A powerful blower circulates the steam in each cavity to increase heating efficiency.

Each cavity holds up to three steam table pans (12" x 20" x 2½"). An 18 gauge stainless steel case encloses the cavities, the steam generators and the control compartment that houses electrical components. Door hinges are reversible (the doors may be set to open from the left or right). Operating Controls are on the front panel.

HY-6E steamers are equipped with fully electronic controls and a button-activated, preprogrammed CLEAN cycle. The On-Off switch is a touch pad control, and the distinctive symbol for steam is integrated into the panel design.

The drain system includes a spray condenser, which helps keep steam from escaping down the condensate drain.



The HY-6E has two independent cavities, each with its own base-mounted steam generator. (New model shown)

Water Conditioning

It is essential to supply the steam generator with water that will not form scale. Even though the steam generator/boiler is engineered to minimize scale formation, scale development depends on the hardness of your water and the number of hours you operate the equipment each day.

Most water supplies contain minerals which form scale. It is this scale which could lead to an early component failure.

Your local water utility can tell you about the minerals in your water. The water going to the steam generator should have between 30 and 40 parts per million (ppm) total dissolved solids (TDS) and should have a pH (acidity rating) of 7.0 to 9.0. Please follow these simple precautions:

1. The best way to prevent scale is to use a Groen PureSteam™ Water Treatment System which has been specifically designed for Groen steamers and combination ovens. **Do not rely on unproven water treatment systems** sold for scale prevention and removal. **They are not specifically designed to work with Groen steamers and combination ovens.**
2. A well-maintained water treatment system and a regular cartridge replacement schedule is essential.

3. Using a Groen PureSteam™ Water Treatment System will provide longer steam generator/boiler life, higher steam capacity, and reduce maintenance requirements.
4. If you notice a slowdown in steam production or an increase in deliming, have the steamer checked for scale build-up. This could be an indication that the water treatment cartridges need replacing. Heavy scale reduces the unit's ability to boil water, and can even cause component failure.

MINIMIZE SCALE PROBLEMS BY INSTALLING AND MAINTAINING A GROEN PureSteam™ WATER TREATMENT SYSTEM AND BY DELIMING THE STEAMER REGULARLY.

The Groen HY-6E Steamer features two separate water inlets — one for the steam generator/boiler (treated water), the other for the spray condenser (untreated water). The second intake will reduce treatment requirements resulting in significant savings.

The dual water connections are side by side on the rear of the unit. When seen from the back of the unit, the treated water intake is on the right.



Inspection and Unpacking

Your HY-6E HyPerSteam will be delivered completely assembled in a heavy shipping carton and attached to a skid. On receipt, inspect the carton carefully for exterior damage.

CAUTION
SHIPPING STRAPS ARE UNDER TENSION AND CAN SNAP BACK WHEN CUT.

Carefully cut the straps around the carton and detach the sides of the carton from the skid. Be careful to avoid personal injury. Strap edges may be very sharp, particularly where cut.

Write down the model number, serial number and installation date. Space for these entries is provided in the Service Log at the back of this manual. Keep the manual near the equipment for reference and update as needed.

CAUTION
THIS UNIT WEIGHS 550 POUNDS. GET HELP AS NEEDED AND USE MATERIAL HANDLING EQUIPMENT TO MOVE IT.

When installing, use material handling equipment to lift the unit straight up from the skid. Check packing materials for any loose parts.

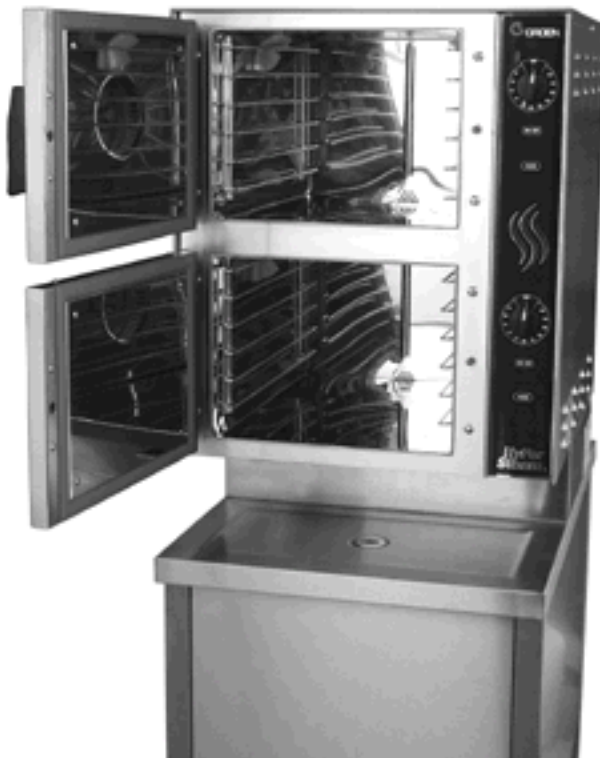

Installation and Start-Up

WARNING

THE UNIT MUST BE INSTALLED BY PERSONNEL WHO ARE QUALIFIED TO WORK WITH ELECTRICITY AND PLUMBING. IMPROPER INSTALLATION CAN CAUSE INJURY TO PERSONNEL AND/OR DAMAGE TO THE EQUIPMENT. THE UNIT MUST BE INSTALLED IN ACCORDANCE WITH APPLICABLE CODES.

CAUTION

DO NOT INSTALL THE UNIT WITH THE RIGHT SIDE VENTS BLOCKED OR WITHIN 12 INCHES OF A HEAT SOURCE (SUCH AS A BRAISING PAN, DEEP FRYER, CHAR-BROILER, OR KETTLE).

TO AVOID DRAINAGE PROBLEMS, LEVEL THE UNIT FRONT TO BACK.

1. Electrical Supply Connection

A. Access for Connection

Panel Removal

Open the wiring and control panel by removing screws from the front panel. Lift the panel, and swing its bottom toward you. Set the panel aside.

B. Supply Voltage

The unit must be operated at the rated nameplate voltage. A temporary fluctuation of plus or minus 10 percent is acceptable.

C. Phase Selection

Refer to the steamer schematic (at the back of this manual) for wiring information.

D. Terminal Block

The terminal block for incoming power is located at the back of the control compartment. The ground terminal is located in the wiring compartment next to the terminal block. **The unit must have a separate ground wire for safe operation.** Minimum size for the ground wire is 10 AWG.

E. Supply Wire

To determine the type of wire you need for the power supply, find the operating voltage and number of phases on the unit data plate. Refer to the table provided on the next page or to the label on the unit's back for the correct wire size and insulation temperature rating. The "Electrical Supply Connection" label inside the unit gives directions for proper connection of the terminal block jumpers. The wire specified has to be used, or the unit will not meet Underwriters Laboratories and National Electrical Code requirements.

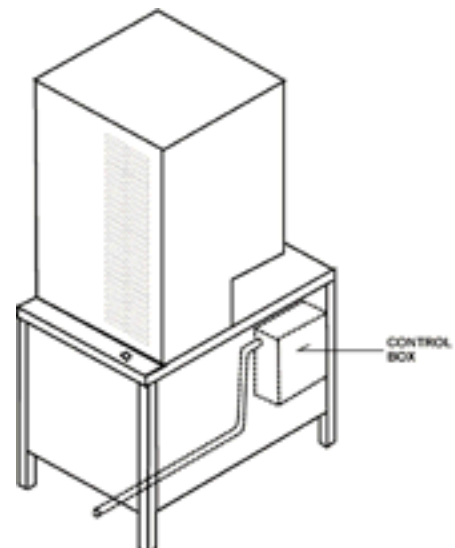

The knockout hole is sized for a one inch conduit fitting. Pass the wire up the back through this knockout hole to the front. Make the connections from the front.



WARNING
TO AVOID DAMAGE OR INJURY, FOLLOW THE ELECTRICAL SCHEMATIC EXACTLY WHEN CONNECTING THE UNIT

ELECTRICAL SUPPLY CONNECTIONS

Voltage	Phase	Wiring Required	Maximum Current	Power
208	1	#2 AWG copper only, at least 75°C #3 AWG copper only, at least 90°C	92 AMP	19 Kw
208	3	#4 AWG copper only, at least 75°C #6 AWG copper only, at least 90°C	53 AMP	19 Kw
240	1	#3 AWG copper only, at least 75°C #4 AWG copper only, at least 90°C	80 AMP	19 Kw
240	3	#6 AWG copper only, at least 75°C #8 AWG copper only, at least 90°C	46 AMP	19 Kw
480	3	#10 AWG copper only, at least 75°C #10 AWG copper only, at least 90°C	23 AMP	19 Kw
480	1	#10 AWG copper only, at least 75°C #10 AWG copper only, at least 90°C	40 AMP	19 Kw

F. Branch Circuit Protection

Each conductor must have over-current protection. Refer to the label on the back of the unit for the proper wire type and size. Connections to the unit must be watertight.

We strongly recommend that the HY-6E Steamer have its own branch circuit protection. Current and power demands for the different units are as follows:

2. Water Connection(s)

Install a check valve to prevent back flow in the incoming cold water line, as required by local plumbing codes. Water pressure in the line should be between 30 and 60 PSIG (210 and 420 kPa). If pressure is above 60 PSIG, a pressure regulator will be needed.

A 3/4 inch NH connector (garden hose type) is used to attach the water supply to the water inlet valve. The minimum water feed line diameter is 1/2 inch (13mm). Use a washer in the hose connection. Do not allow the connection to leak, no matter how slow it may be.

If you have the dual water connection option, put the treated water (softened) to the right intake (looking from the rear of the unit), and untreated water to the left. Connections for both are made as described above.

Drain Connection

The HY-6E Steamer must be leveled front to back. A 1½ inch (38mm) ID hose may be attached to the drain pipe by means of a hose.

Do NOT use plastic pipe. The drain must withstand boiling water.

Install the drain line with a constant downward pitch. **Do not allow any water traps in the line. A trap can cause pressure to build up inside the cavity during steaming, which will make the door gasket leak.**

IMPROPER CONNECTION OF THE DRAIN WILL VOID YOUR WARRANTY

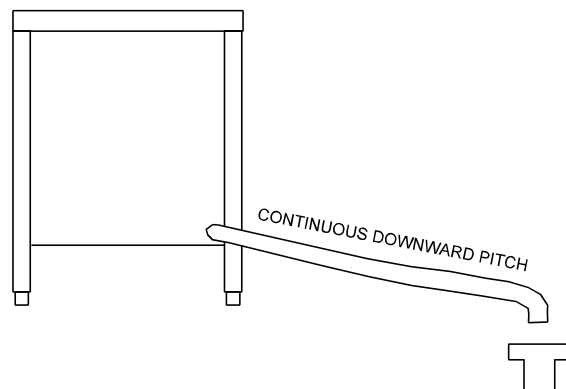
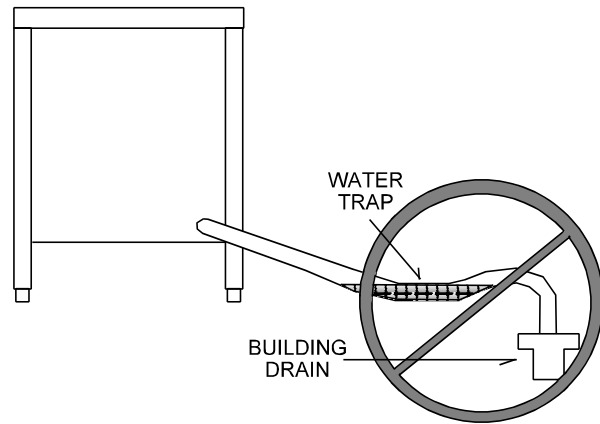

Don't allow water traps in the hose.

Operation

WARNING
ANY POTENTIAL USER OF THE EQUIPMENT SHOULD BE TRAINED IN SAFE AND CORRECT OPERATING PROCEDURES.

A. Controls

Operator controls are on the front right of the unit.

The HY-6E and HY-3E control panels has the following touch pads and indicator lights:

- ! The ON/OFF touch pad gets the HyPerSteam ready for use, or shuts it off.
- ! The READY indicator light shows that the steam generator is at standby temperature and the cavity is hot enough to begin steaming.
- ! The DELIME indicator light is lit when the unit is operating in the cleaning mode.
- ! The SERVICE indicator light shows when the water level probes have stopped working, and need to be cleaned (normally an indication of lime deposits).

When one probe fails, the SERVICE light flashes briefly every few seconds, but the unit will continue to operate. De-lime the unit as soon as possible.

*If the problem continues, both probes may fail. Then the steamer stops working, the light will flash repeatedly and the beeper will sound. **At this point you must turn off the power and contact an Authorized Groen Service Representative for repair.***

- ! The HI TEMP indicator light comes on when the steam generator is too hot.

The unit will automatically shut off, and cannot be turned on again until the steam generator cools and the HI TEMP indicator light goes out.

- ! The TIMING indicator light stays on when the timer is running.
- ! The CLEAN touch pad is used to start the automatic 50 minute cleaning cycle.

The ON/OFF pad readies the HyPerSteam for use or shuts it off. The READY light shows the steam generator is at standby temperature and the cavity is

hot enough to start steaming.

The timer is used in three ways:

- 1 In the OFF position the steam generator stays at a low boil or “holding” temperature.
- 2 When a cook time is set, the unit steams until the timer runs down to OFF. At that time steaming stops, a red light comes on and a beeper sounds.
- 3 With the timer turned to the ON position, the unit steams continuously. The green light stays lit. The steamer will **not** time down.

B. Operating Procedure

1. Press the ON/OFF touch pad for the steamer. The steam generator will fill, and heat until the READY light comes on. (Aprox. 10 minutes.)
2. Load food into pans in uniform layers. Pans should be filled to about the same levels, and should be even on top.
3. Open the door and slide the pans onto the supports. If you will only be steaming one pan, put it in the middle position.
4. Close the door. With the READY indicator lit, take one of the following steps:
 - ! If you want to steam the food for a certain length of time, set the timer for that period. The timer will automatically run the steamer for the set time and then turn it off. A red light will come on and a beeper will sound. Steam production stops.
 - ! If you want to steam continuously, turn the timer to the manual ON position. A green light will come on. The unit will continue steaming until you stop it by turning the timer to OFF. When steaming continuously YOU MUST CONTROL STEAMING TIME.



WARNING
WHEN YOU OPEN THE DOOR, STAY AWAY
FROM THE STEAM COMING OUT OF THE UNIT.
THE STEAM CAN CAUSE BURNS.

5. Open the door. Remove the pans from the steamer, using hot pads or oven mitts to protect your hands from the hot pans.
6. To shut down the unit, press the ON/OFF touch pad to OFF. The steam generator will automatically drain.



Cleaning

To keep your HY-6E Steamer in proper working condition/order, use the following procedure to clean the unit. This regular cleaning will reduce the effort required to clean the steam generators and cavities.

A. Suggested Tools

1. Mild detergent
2. Stainless steel exterior cleaner such as Zepper®
3. Steam generator de-liming agent, such as **Groen Delimer Descaler (P/N 114800)**, Lime-Away® or an equivalent. A liquid de-liming agent will be easier to use than crystals or powders. See the warning about chlorides, below
4. De-greaser, such as EncompasS®, Malone 34®, Puritan Puribrute®, or Con-Lie®
5. Cloth or sponge
6. Plastic wool or a brush with soft bristles
7. Spray bottle
8. Measuring cup
9. Nylon pad
10. Towels
11. Plastic disposable gloves
12. Funnel



B. Procedure

1. Outside

- a. Prepare a warm solution of the mild detergent as instructed by the supplier. Wet a cloth with this solution and wring it out. Use the moist cloth to clean the outside of the unit. Do not allow freely running liquid to touch the controls, the control panel, any electrical part, or any open louver.
- b. To remove material which may be stuck to the unit, use plastic wool, a fiber brush, or a plastic or rubber scraper with a detergent solution.
- c. Stainless steel surfaces may be polished with a recognized stainless steel cleaner such as Zepper®.



WARNING

DISCONNECT THE POWER SUPPLY BEFORE CLEANING THE OUTSIDE OF THE STEAMER.

KEEP WATER AND CLEANING SOLUTIONS OUT OF CONTROLS AND ELECTRICAL COMPONENTS. NEVER HOSE OR STEAM CLEAN ANY PART OF THE UNIT.

DON'T MIX DE-LIMING AGENTS (ACID) WITH DE-GREASERS (ALKALI) ANYWHERE IN THE UNIT

AVOID CONTACT WITH ANY CLEANERS, DE-LIMING AGENT OR DE-GREASER AS RECOMMENDED BY THE SUPPLIER. MANY ARE HARMFUL. READ THE WARNINGS AND FOLLOW THE DIRECTIONS!

EVEN WHEN THE UNIT HAS BEEN SHUT OFF, DON'T PUT HANDS OR TOOLS INTO THE COOKING CHAMBER UNTIL THE FAN HAS STOPPED TURNING.

DON'T OPERATE THE UNIT UNLESS THE TWO REMOVABLE INTERIOR FAN BAFFLE PARTITIONS HAVE BEEN PUT BACK IN THEIR PROPER LOCATIONS.

DON'T USE ANY CLEANING OR DE-LIMING AGENT THAT CONTAINS ANY SULFAMIC AGENT OR ANY CHLORIDE, INCLUDING HYDROCHLORIC ACID (HCl). TO CHECK FOR CHLORIDE CONTENT SEE ANY MATERIAL SAFETY DATA SHEETS PROVIDED BY THE CLEANING AGENT MANUFACTURER.

IMPORTANT

DO NOT USE ANY METAL MATERIAL (SUCH AS METAL SPONGES) OR METAL IMPLEMENT (SUCH AS A SPOON, SCRAPER OR WIRE BRUSH) THAT MIGHT SCRATCH THE SURFACE. SCRATCHES MAKE THE SURFACE HARD TO CLEAN AND PROVIDE PLACES FOR BACTERIA TO GROW. DO NOT USE STEEL WOOL, WHICH MAY LEAVE PARTICLES IMBEDDED IN THE SURFACE WHICH COULD EVENTUALLY CAUSE CORROSION AND PITTING.

2. Steam Generator and Cooking Chamber

Regular deliming, depending on your steamer usage and local water quality, must be done to enhance performance and prolong the life of your HyPerSteam™ convection steamer. Steamer must be turned off after every use to prevent lime scale buildup - do not run steamer continuously.

ALWAYS USE HOT PADS OR MITTS WHEN HANDLING HOT STEAMER PANELS OR RACKS.

RECOMMENDED TOOLS & CLEANERS:

- Groen Delimer/Descaler (Part Number 114800). **Do NOT use any product containing chlorides or sulfamic acid, including hydrochloric acid .**
- Nylon scrub pad, cloth and/or sponge

DELIMING STEPS HY-6E (Use Touch Pad):

1. Press ON/OFF to turn off. Open door(s).
2. Let cavity cool for 5 minutes or longer. While cool, wipe out cavity. Drain holes at rear of cavity must be clear of debris. Close door(s).
3. Press and hold CLEAN while turning steamer on pressing ON/OFF, until only DELIME and POWER light remain on (all lights will turn on, then off, except DELIME and POWER.
4. After 5 minutes, beeper will beep rapidly, signaling you to add Groen Delimer/Descaler. Door(s) must remain closed for entire delime cycle.
5. Pour 1 pint (2 cups) of delimer per cavity into upper and/or lower delimer ports(s). Press CLEAN. Double -stacked unit cavities may be delimed together or separately.

6. Delime cycle will start, taking about 30 minutes. When delime cycle is complete, DELIME light will appear, DONE light will flash and beeper will beep.
7. Press ON/OFF to turn steamer off. Let cavity cool for 5 minutes or longer. Open door(s), wipe out inside of cavity and wipe door gasket.
8. To use steamer, press ON/OFF. When READY light appears, steamer is ready to use.

NOTES:

- If delime light flashes rapidly (5 times per second), press DELIME to restart delime cycle.
- If power outage occurs during deliming, delime cycle must be restarted. Press DELIME.
- For best performance, do not interrupt delime cycle. If delime cycle must be stopped, press ON/OFF to turn off. Let cavity cool for 5 minutes or longer. Press ON/OFF to turn on. Set timer for 5 minutes. After beeper beeps, press ON/OFF to turn off. Let cavity cool for 5 minutes or longer, carefully open door(s) and wipe out cavity completely.

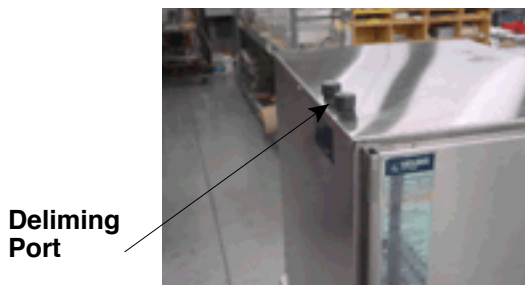

Maintenance

The HY-6E Steamer is designed for minimum maintenance, and no user adjustments should be necessary. Certain parts may need replacement after prolonged use. If there is a need for service, only Groen personnel or authorized Groen representatives should perform the work.

Always supply water with a low mineral count that meets the standards outlined in the **Water Conditioning** section of this manual.

If steam or condensate is seen leaking from around the door, take the following steps:

- a. Check the door gasket. Replace if it is cracked or split.
- b. Inspect the cooking chamber drain to be sure it is not blocked.

- c. Adjust the door latch pin to allow for changes that might occur as the gasket ages.
 - ! Loosen the lock nut at the base of the latch pin. Turn the latch pin ¼ turn clockwise, and re-tighten the lock nut.
 - ! After adjustment, run the unit to test for further steam leakage.
 - ! If there is still leakage, repeat the adjustment.
 - ! Continue adjusting the pin clockwise until the door fits tightly enough to prevent leakage.

Troubleshooting

This Groen Steamer is designed to operate smoothly and efficiently if properly maintained. However, the following is a list of checks to make in the event of a problem. Wiring diagrams are furnished inside the service panel. If an item on the check list is marked with (✕), it means that the work should be done by a factory-authorized service representative.

SYMPTOM	WHO	WHAT TO CHECK
! Steam generator does not fill with water.	User	<ul style="list-style-type: none"> a. Is the ON switch depressed? b. Is the water supply connected? c. Is the water turned on? d. Check for low water pressure (less than 30 PSI or 210 kPa). e. Is the screen at the water connection clogged? f. Has the steam generator been de-limed?
! No steam.	User	<ul style="list-style-type: none"> a. Is the ON switch depressed? b. Is the water supply connected? c. Is the water turned on? d. Are steamer doors open? e. Is the steam generator limed up?
! SERVICE indicator light comes on after four minutes.	User	<ul style="list-style-type: none"> a. Is the water supply connected? b. Is the water turned on? c. Has the unit been de-limed? (Refer to Cleaning Section)
! Excessive steam escaping from rear of unit	User	<ul style="list-style-type: none"> a. Is the condensate spray hose kinked or obstructed?
	Auth Service Rep Only	<ul style="list-style-type: none"> b. Is the water spray solenoid connected?(✕) c. Is the drain properly vented? (✕)