

OPERATOR MANUAL

Part Number 148666 Rev. C

OM-HY-5E/HY-3E

DOMESTIC

MODELS: HY-3E, (2)HY-3E,
HY-5E, (2)HY-5E
HyPerSteam™
Atmospheric Convection
Steamer (Re-Designed)

*Self-Contained
Electric Heated*

*Capacity: 5 Steamer Pans [per cavity] (HY-5E)
3 Steamer Pans [per cavity] (HY-3E)
(12" x 20" x 2 1/2")*

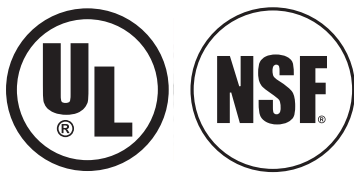

THIS MANUAL MUST BE RETAINED FOR FUTURE REFERENCE. READ, UNDERSTAND AND FOLLOW THE INSTRUCTIONS AND WARNINGS CONTAINED IN THIS MANUAL.

**FOR YOUR SAFETY
DO NOT STORE OR USE GASOLINE OR OTHER FLAMMABLE VAPORS AND LIQUIDS IN THE VICINITY OF THIS OR ANY OTHER APPLIANCE.**



IMPORTANT — READ FIRST — IMPORTANT

- WARNING:** THE UNIT MUST BE INSTALLED BY PERSONNEL QUALIFIED TO WORK WITH ELECTRICITY AND PLUMBING. IMPROPER INSTALLATION CAN CAUSE INJURY TO PERSONNEL AND/OR DAMAGE TO THE EQUIPMENT. THE UNIT MUST BE INSTALLED IN ACCORDANCE WITH APPLICABLE CODES.
- CAUTION:** SHIPPING STRAPS ARE UNDER TENSION AND CAN SNAP BACK WHEN CUT.
- CAUTION:** DO NOT INSTALL THE UNIT IN ANY WAY WHICH WILL BLOCK THE SIDE VENTS, OR WITHIN 12 INCHES OF A HEAT SOURCE SUCH AS A BRAISING PAN, DEEP FRYER, CHAR BROILER OR KETTLE.
- CAUTION:** LEVEL THE UNIT FRONT TO BACK, OR PITCH IT SLIGHTLY TO THE REAR, TO AVOID DRAINAGE PROBLEMS.
- WARNING:** FOLLOW THE WIRING DIAGRAM EXACTLY WHEN CONNECTING A UNIT TO AVOID DAMAGE OR INJURY.
- CAUTION:** DO NOT USE PLASTIC PIPE. DRAIN MUST BE RATED FOR BOILING WATER.
- WARNING:** DO NOT CONNECT THE DRAIN DIRECTLY TO A BUILDING DRAIN.
- WARNING:** BLOCKING THE DRAIN IS HAZARDOUS.
- Important:** Improper drain connection will void warranty.
- Important:** Do not allow any water traps in the line. A trap can cause pressure to build up inside the cavity during steaming, which will make the door gasket leak.
- WARNING:** WHEN YOU OPEN THE DOOR, STAY AWAY FROM STEAM COMING OUT OF THE UNIT. STEAM CAN CAUSE BURNS.
- WARNING:** BEFORE CLEANING THE OUTSIDE OF THE STEAMER, DISCONNECT THE ELECTRIC POWER SUPPLY. KEEP WATER AND CLEANING SOLUTIONS OUT OF CONTROLS AND ELECTRICAL COMPONENTS. NEVER HOSE OR STEAM CLEAN ANY PART OF THE UNIT.
- WARNING:** ALLOW COOKING CHAMBER TO COOL BEFORE CLEANING.
- WARNING:** CAREFULLY READ THE WARNINGS AND FOLLOW THE DIRECTIONS ON THE LABEL OF EACH CLEANING AGENT. USE SAFETY GLASSES AND RUBBER GLOVES AS RECOMMENDED BY DELIMING AGENT MANUFACTURER.
- WARNING:** DO NOT MIX DE-LIMING AGENTS (ACID) AND DE-GREASERS (ALKALI).
- WARNING:** DO NOT PUT HANDS OR TOOLS INTO THE COOKING CHAMBER UNTIL THE FAN HAS STOPPED TURNING.
- WARNING:** DO NOT OPERATE THE UNIT UNLESS THE REMOVABLE RIGHT SIDE PANEL HAS BEEN RETURNED TO ITS PROPER LOCATION.
- NOTICE:** DO NOT USE A CLEANING OR DE-LIMING AGENT THAT CONTAINS ANY SULFAMIC ACID OR ANY CHLORIDE, INCLUDING HYDROCHLORIC ACID. IF THE CHLORIDE CONTENT OF ANY PRODUCT IS UNCLEAR, CONSULT THE MANUFACTURER.
- NOTICE:** DO NOT USE ANY DE-GREASER THAT CONTAINS POTASSIUM HYDROXIDE OR SODIUM HYDROXIDE OR THAT IS ALKALINE.
- WARNING:** USE OF ANY REPLACEMENT PARTS OTHER THAN THOSE SUPPLIED BY GROEN OR THEIR AUTHORIZED DISTRIBUTOR VOIDS ALL WARRANTIES AND CAN RESULT IN BODILY INJURY TO THE OPERATOR AND DAMAGE THE EQUIPMENT. SERVICE BY OTHER THAN FACTORY-AUTHORIZED PERSONNEL WILL VOID ALL WARRANTIES.
- WARNING:** HIGH VOLTAGE EXISTS INSIDE CONTROL COMPARTMENTS. DISCONNECT FROM BRANCH CIRCUIT BEFORE SERVICING. FAILURE TO DO SO CAN RESULT IN SERIOUS INJURY OR DEATH.

Table of Contents

OPERATOR WARNINGS 2

REFERENCES 3

EQUIPMENT DESCRIPTION 4

INSPECTION AND UNPACKING 4

WATER CONDITIONING 5

INSTALLATION AND START-UP 6

OPERATION 9

CLEANING 11

MAINTENANCE 13

TROUBLESHOOTING 13

SERVICE LOG 14

WARRANTY PROTECTION 15

References

UNDERWRITERS LABORATORIES, INC.
333 Pfingsten Road
Northbrook, Illinois 60062

NATIONAL FIRE PROTECTION ASSOCIATION
60 Batterymarch Park
Quincy, Massachusetts 02269

NFPA/70 The National Electrical Code

NSF INTERNATIONAL
789 N. Dixboro Rd.
P.O. Box 130140
Ann Arbor, Michigan 48113-0140

Equipment Description

Your Groen HY-5E or HY-3E HyPerSteam Convection Steamer is designed to give years of service. It has a stainless steel cavity (cooking chamber) which is served by an independent atmospheric steam generator which is electrically-heated. A powerful blower circulates the steam in the cavity to increase heating efficiency.

The cavity holds up to five (HY-5E) or three (HY-3E) steam table pans (12" x 20" x 2½" deep). An 18 gauge stainless steel case encloses the cavity, the steam generator and the control compartment that houses electrical components. Door hinges are reversible (the door may be set to open from the left or right). Operating Controls are on the front panel.

HY-3E and HY-5E steamers are equipped with fully electronic controls and a button-activated, pre-programmed CLEAN cycle. These units are readily identified by their unique control panels. The On-Off switch is operated by touch pad controls, and the distinctive symbol for steam is integrated into the panel. The new models also have fewer panel louvers on the right side.

From the rear HY-3E and HY-5E units are distinguished by the addition of a fuse box, which lets operators change fuses without removing panels.

The drain system on all models includes a spray condenser, which helps keep steam from escaping from the chamber and cools drain water.



The HY-3E steamer holds three standard 12" x 20" x 2½" steamer pans.



The HY-5E holds up to five pans.

Inspection and Unpacking

The Steamer will be delivered completely assembled in a heavy shipping carton strapped to a skid. On receipt, inspect carton carefully for exterior damage.

CAUTION
SHIPPING STRAPS ARE UNDER TENSION AND CAN SNAP BACK WHEN CUT.

Carefully cut the straps and detach the sides of the carton from the skid. Pull the carton up off the unit. Be careful to avoid personal injury or equipment damage from staples which might be left in the carton walls.

CAUTION
THE HY-5E WEIGHS 230 POUNDS (104 KG).
THE THE HY-3E WEIGHS 180 POUNDS (82 KG).
YOU SHOULD GET HELP AS NEEDED TO LIFT THIS WEIGHT SAFELY.

Write down the model number, serial number and installation date. Keep this information for reference. Space for these entries is provided at the top of the Service Log in the back of this manual.

When starting installation, check packing materials to make sure loose parts such as the condensate drip tray are not discarded with this material.

Water Conditioning

It is essential to supply the steam generator with water that will not form scale. Even though the steam generator is engineered to minimize scale formation, scale development depends on the hardness of your water and the number of hours per day you operate the equipment.

Most water supplies are full of minerals which form scale. It is this scale which could lead to an early component failure.

Your water utility can tell you about the minerals in your water. The water going to the steam generator should have more than 10 to 30 parts per million (ppm) total dissolved solids (TDS) and should have a pH (acidity rating) of 7.0 or higher. Please follow these simple precautions:

1. The best way to prevent scale is to use a Groen PureSteem™ Water Treatment System which has been specifically designed for Groen steamers and combination ovens. **Do not rely on unproven water treatment systems** sold for scale prevention and removal. **They are not specifically designed to work with Groen steamers and combination ovens.**
2. A well-maintained water treatment system and a regular cartridge replacement schedule is essential.
3. Using a Groen PureSteem™ Water Treatment System will provide longer steam generator/boiler life, higher steam capacity, and reduce maintenance requirements.
4. If you notice a slowdown in steam production or an increase in deliming, have the steamer checked for scale build-up. This could be an indication that the water treatment cartridges need replacing. Heavy scale reduces the unit's ability to boil water, and can even cause component failure.

MINIMIZE SCALE PROBLEMS BY USING AND MAINTAINING A SOFTENER AND BY CLEANING (DELIMING) THE STEAMER REGULARLY.

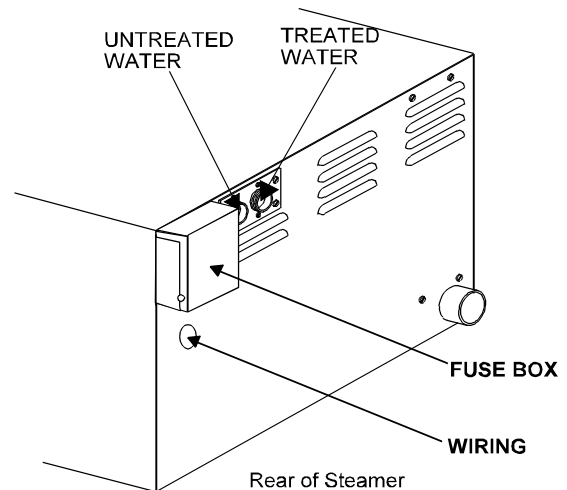

Models built since 1998 have a fuse box mounted on the rear.

On both the HY-3E and HY-5E, the dual water connections are side by side on the rear of the unit. When seen from the back of the unit, the treated (softened) water intake is on the right.

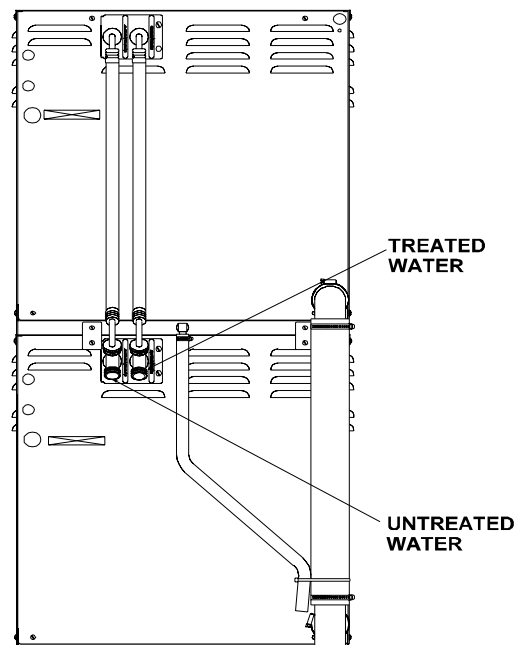

(2) HY-5E (Rear View)

Installation and Start-Up

WARNING
THE UNIT MUST BE INSTALLED BY PERSONNEL WHO ARE QUALIFIED TO WORK WITH ELECTRICITY AND PLUMBING. IMPROPER INSTALLATION CAN CAUSE INJURY TO PERSONNEL AND/OR DAMAGE TO THE EQUIPMENT. THE UNIT MUST BE INSTALLED IN ACCORDANCE WITH APPLICABLE CODES.

CAUTION
DO NOT INSTALL THE UNIT WITH THE RIGHT OR LEFT SIDE VENTS BLOCKED OR WITHIN 12 INCHES OF A HEAT SOURCE (SUCH AS A BRAISING PAN, DEEP FAT FRYER, CHARBROILER OR KETTLE).

TO AVOID DRAINAGE PROBLEMS, LEVEL THE UNIT FRONT TO BACK.

1. Electrical Supply Connection

A. Panel Removal

Open the wiring and control panel by removing screws from the right side panel. Slide the panel forward, and set it aside.

B. Supply Voltage

The unit must be operated at the rated nameplate voltage.

C. Phase Selection

Refer to steamer schematics (Pages 20-21) for wiring information.

CAUTION
EACH UNIT MUST HAVE A SEPARATE GROUND WIRE FOR SAFE OPERATION.

D. Terminal Block

The terminal block for incoming power is located at the back of the control compartment. The ground terminal is located in the wiring compartment near the terminal block.

E. Supply Wire

To determine the type of wire you need for the power supply, find the operating voltage and number of phases on the unit data plate. Refer to the table below or to the label on the unit's back for correct wire size and temperature rating. The equipment grounding wire must comply with the National Electrical Code (NEC) requirements. The schematic on the inside of the unit's right side cover gives directions for proper connection of the terminal block jumpers. The specified wire must be used, or the unit will not meet Underwriters Laboratories and NEC requirements. The knockout hole is sized for a 3/4 inch conduit fitting on the HY-3E and for a one inch conduit fitting on the HY-5E.



WARNING
TO AVOID DAMAGE OR PERSONAL INJURY, FOLLOW THE ELECTRICAL SCHEMATIC EXACTLY WHEN CONNECTING THE UNIT.

ELECTRICAL SUPPLY CONNECTIONS

FIELD WIRING TABLE - USE COPPER WIRE ONLY - INSULATION RATING THHN (90°C)

VOLTAGE (60 Hz Only)	KW		FIELD WIRING		RATED CURRENT DEMAND	
	HY-3E	HY-5E	HY-3E	HY-5E	HY-3E	HY-5E
480 3 PHASE	8.1	15.5	14 AWG	12 AWG	10 Amps	18.6 Amps
240 1 PHASE	8.1	15.5	8 AWG	4 AWG	33 Amps	64.6 Amps
240 3 PHASE	8.1	15.5	10 AWG	8 AWG	20 Amps	37.3 Amps
208 1 PHASE	8.1	15.5	8 AWG	4 AWG	39 Amps	74.5 Amps
208 3 PHASE	8.1	15.5	10 AWG	6 AWG	23 Amps	43.0 Amps

Branch Circuit Protection

Each Steamer, including individual units of stacked models, should have its own branch circuit protection and ground wire. Current and power demands for each unit are as shown on Page six.

2. Water Connection(s)

Install a check valve to prevent back flow in the incoming cold water line, as required by local plumbing codes. Water pressure in the line should be between 30 and 60 PSIG and must deliver a flow rate of 1.5 to 3.0 gallons per minute. If pressure is above 60 PSIG, a pressure regulator will be needed.

A ¾ inch female NH connector (garden hose type) is used to attach the water supply to the inlet valve. **Minimum inside diameter of the water feed line is ½ inch.** Use a washer in the hose connection. Do not allow the connection to leak, no matter how slowly. The dual water standard connection, treated (softened) water goes to the right (seen from the rear of the unit), and untreated water to the left. Connections for both are made as shown on Page Five.

3. Drain Connection

Level the steamer front to back, or pitch it slightly to the rear (maximum ¼ inch) by adjusting the bullet feet on the stand or cabinet base.

A 2 inch [HY-5E] or 1½ inch [HY-3E] ID hose may be attached to the drain pipe (supplied).

**WARNING:
DO NOT CONNECT THE DRAIN DIRECTLY TO A BUILDING DRAIN. BLOCKING THE DRAIN IS HAZARDOUS.**

There must be a free air gap between the end of the hose and the building drain. The free air gap should be as close as possible to the unit drain. There must also be no other elbows or other restrictions between the unit drain and the free air gap.

**CAUTION
DO NOT USE PLASTIC PIPE. DRAIN MUST BE RATED FOR BOILING WATER.**

Install the drain line with a constant downward pitch.

IMPORTANT: Do not allow water traps in the line. A trap can cause pressure build-up in the cavity, which may cause the door gasket to leak.

4. Factory Stacked Units

This section is applicable only if you are installing factory-stacked units. If you plan to stack steamers yourself, whether purchasing a new one for stacking or a kit to stack two units you already own, you will require **OM-HY-3E(S), RETROFIT SUPPLEMENT** (Part Number 121014). These instructions are also valid for stacking HY-5E steamers.

Installing stacked steamers is similar to installing a single unit. The steamers are stacked and assembled at the factory and delivered with the water connections and drain hoses required for a single point connection.

A. Water Connection

At the water inlet valve a ¾ inch female NH connector (garden hose type) is used for the water supply. The dual water connection has two connections to be made. Treated water (softened) is connected to the right valve fitting (looking from the rear of the unit) and untreated water to the left fitting.

B. Electrical Supply Connection

Separate, individual electrical connections will be required for each steamer in the stack. Each Steamer must have its own branch circuit protection.

C. Drain Connection

Steamers must be leveled front to back, or pitched to the rear (maximum ¼ inch) by adjusting the bullet feet on the cabinet or stand base.

For HY-3E a 1½ inch and for HY-5E a 2 inch ID hose may be attached to the unit drain. It must be rated for boiling water.

WARNING
DO NOT CONNECT THE UNIT DRAIN DIRECTLY TO THE BUILDING DRAIN.

Ensure that there is a free air gap between the end of the unit drain and the building drain. This gap should be as close as possible to the unit drain. Do not allow elbows or restrictions between the unit and the free air gap.

CAUTION
DO NOT USE PLASTIC PIPE. DRAIN MUST BE RATED FOR BOILING WATER.

Install the line with a constant downward pitch.



Rear view of (2) HY-5E — Note: Some drain parts (elbow, clamps) for single models are packed inside the steamer cavity. Stacked units are factory-assembled. Installation is the same for stacked HY-5E and HY-3E units.

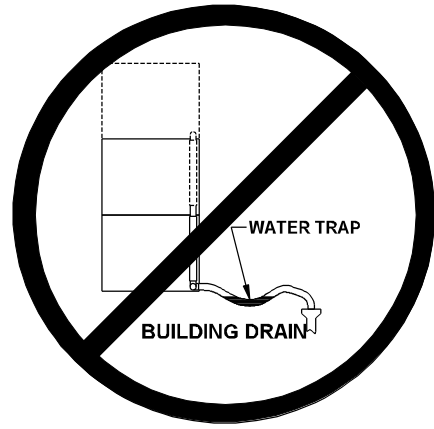

IMPROPER DRAIN LINE CONNECTION

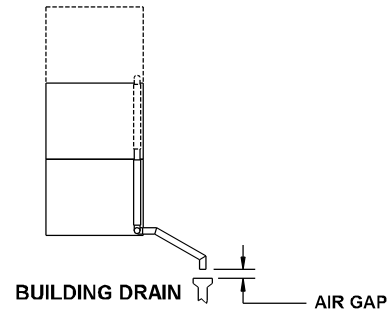

Proper Drain Line Connection — Drain Line must have a constant downward pitch of at least 1/4" per foot. (3)HY-3E shown. Connection is 1 1/2" for HY-3E, 2" for HY-5E.

Operation

WARNING
ANY POTENTIAL USER OF THE EQUIPMENT MUST BE TRAINED IN SAFE AND CORRECT OPERATING PROCEDURES.

A. Controls

Operator controls are on the front right of the unit.

The HY-5E and HY-3E control panels have the following touch pads and indicator lights:

- 1 The ON/OFF touch pad gets the HyPerSteam ready for use, or shuts it off.
- 2 The READY indicator light shows that the steam generator is at standby temperature and the cavity is hot enough to begin steaming.
- 3 When one probe is covered with lime scale or fails, the DELIME light flashes briefly every few seconds, but the unit will continue to operate. De-lime the unit as soon as possible. The DELIME light will flash until power is removed from the unit, or the unit goes through a clean cycle.
- 4 If the problem continues, both probes may fail. Then the steamer stops working, and the

SERVICE light is lit. If **DELIMING/CLEANING does not correct, turn off the power and contact an Authorized Groen Service Representative for repair.**

- 5 The DELIME indicator light is lit when the unit is operating in the cleaning mode.
- 6 The HI TEMP indicator light comes on when the steam generator is too hot.
The unit will automatically shut off, and cannot be turned on again until the steam generator cools and the HI TEMP indicator light goes out.
- 8 The TIMING indicator light stays on when the timer is running.
- 9 The CLEAN touch pad is used to start the automatic 50 minute cleaning cycle.

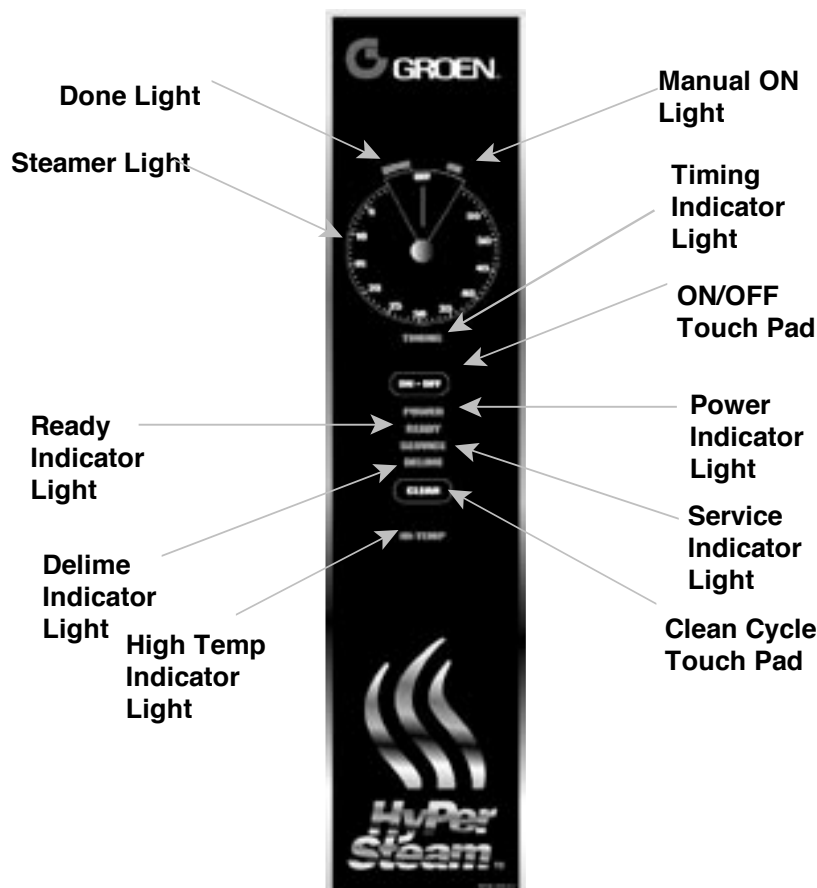

The timer is used in three ways:

- 1 In the OFF position the steam generator stays at a low boil or “holding” temperature.
- 2 When a cook time is set, the unit steams until the timer runs down to OFF. At that time steaming stops, a red light comes on and a beeper sounds.
- 3 With the timer turned to the ON position, the unit steams continuously. The green light stays lit. The steamer will **not** time down.

B. Operating Procedure

1. Press the ON/OFF touch pad for the steamer. The steam generator will fill, and heat until the READY light comes on. (About 10 minutes.)
2. Load food into pans in uniform layers. Pans should be filled to about the same levels, and should be even on top.
3. Open the door and slide the pans onto the supports. If you will only be steaming one pan, put it in the middle position.
4. Close the door. With the READY indicator lit, take one of the following steps:
 - If you want to steam the food for a certain length of time, set the timer for that period. The timer will automatically run the steamer for the set time and then turn it off. A red light will come on and a beeper will sound. Steam production stops.
5. Open the door. Remove the pans from the steamer, using hot pads or oven mitts to protect your hands from the hot pans.
6. To shut down the unit, press the ON/OFF touch pad to OFF. The steam generator will automatically drain.

- If you want to steam continuously, turn the timer to the manual ON position. A green light will come on. The unit will continue steaming until you stop it by turning the timer to OFF. When steaming continuously YOU MUST CONTROL STEAMING TIME.



WARNING
WHEN YOU OPEN THE DOOR, STAY AWAY
FROM THE STEAM COMING OUT OF THE UNIT.
THE STEAM CAN CAUSE BURNS.

Cleaning

To keep your HY-3E or HY-5E Steamer in proper working condition, use the following procedure to clean the unit. This regular cleaning will reduce the effort required to clean the steam generator and cavity.

A. Suggested Tools

1. Mild detergent
2. Stainless steel exterior cleaner such as Zepper®
3. Steam generator de-liming agent, such as **Groen Delimer Descaler (Part Number 114800)**, Lime-Away® or an equivalent. A liquid de-liming agent will be easier to use than crystals or powders. **Do NOT use any product containing chlorides or sulfamic acid, including hydrochloric acid.**
4. Groen Spray De-Greaser (Part Number 140830WS)
5. Cloth or sponge
6. Plastic wool or a brush with soft bristles
7. Spray bottle
8. Measuring cup
9. Nylon pad
10. Towels
11. Plastic disposable gloves
12. Funnel



B. Procedure

1. Exterior Cleaning

- a. Prepare a warm solution of the mild detergent as instructed by the supplier. Wet a cloth with this solution and wring it out. Use the moist cloth to clean the outside of the unit. Do not allow freely running liquid to touch the controls, the control panel, any electrical part, or any louver on the side or rear panels.
- b. To remove material which may be stuck to the unit, use plastic wool, a fiber brush, or a plastic or rubber scraper with a detergent solution.
- c. Stainless steel surfaces may be polished with a recognized stainless steel cleaner such as Zepper®.



WARNING

DISCONNECT THE POWER SUPPLY BEFORE CLEANING THE OUTSIDE OF THE STEAMER.

KEEP WATER AND CLEANING SOLUTIONS OUT OF CONTROLS AND ELECTRICAL COMPONENTS. NEVER HOSE OR STEAM CLEAN ANY PART OF THE UNIT.

DON'T MIX DE-LIMING AGENTS (ACID) WITH DE-GREASERS (ALKALI) ANYWHERE IN THE UNIT.

AVOID CONTACT WITH ANY CLEANERS, DE-LIMING AGENT OR DE-GREASER AS RECOMMENDED BY THE SUPPLIER. MANY ARE HARMFUL. READ THE WARNINGS AND FOLLOW THE DIRECTIONS!

EVEN WHEN THE UNIT HAS BEEN SHUT OFF, DON'T PUT HANDS OR TOOLS INTO THE COOKING CHAMBER UNTIL THE FAN HAS STOPPED TURNING.

DON'T OPERATE THE UNIT UNLESS THE REMOVABLE PARTITION HAS BEEN PUT BACK IN ITS PROPER LOCATION.

DON'T USE ANY CLEANING OR DE-LIMING AGENT THAT CONTAINS ANY SULFAMIC AGENT OR ANY CHLORIDE, INCLUDING HYDROCHLORIC ACID (HCl). TO CHECK FOR CHLORIDE CONTENT SEE ANY MATERIAL SAFETY DATA SHEETS PROVIDED BY THE CLEANING AGENT MANUFACTURER.

IMPORTANT

DO NOT USE ANY METAL MATERIAL (SUCH AS METAL SPONGES) OR METAL IMPLEMENTS (SUCH AS A SPOON, SCRAPER OR WIRE BRUSH) THAT MIGHT SCRATCH ANY STAINLESS STEEL SURFACE. SCRATCHES MAKE THE SURFACE HARD TO CLEAN AND PROVIDE PLACES FOR BACTERIA TO GROW. DO NOT USE STEEL WOOL, WHICH MAY LEAVE PARTICLES IMBEDDED IN THE SURFACE WHICH COULD EVENTUALLY CAUSE CORROSION AND PITTING.

OM-HY-5E/HY-3E

2. Steam Generator and Cooking Chamber

Regular deliming, depending on your steamer usage and local water quality, must be done to enhance performance and prolong the life of your HyPerSteam™ convection steamer. Steamer must be turned off after every use to prevent lime scale buildup - do not run steamer continuously.

ALWAYS USE HOT PADS OR MITTS WHEN HANDLING HOT STEAMER PANELS OR RACKS.

RECOMMENDED TOOLS & CLEANERS:

- Groen Delimer/Descaler (Part Number 114800). **Do NOT use any product containing chlorides or sulfamic acid, including hydrochloric acid .**
- Nylon scrub pad, cloth and/or sponge

DELIMING STEPS HY-3E/5E (Use Touch Pad):

- STEP 1 - Press ON/OFF to turn steamer off. Open door.
- STEP 2 - **Let cavity cool for 5 minutes or longer.** While cool, wipe out cavity. Close door.
- STEP 3 - Press and hold CLEAN while also turning steamer on by pressing ON/OFF, until only DELIME and POWER lights remain on (all lights will turn on, then off, except DELIME and POWER).
- STEP 4- After 5 minutes, beeper will beep rapidly, signaling you to add Groen Delimer/Descaler. Door(s) must remain closed for entire delime cycle.
- STEP 5- Pour 1 pint (2 cups) of delimer PER CAVITY into upper and /or lower delimiting port(s) and then close port(s). Press CLEAN. Double-stacked unit cavities may be delimed together or seperately.

Delimiting Port



STEP 6- Delime cycle will start, taking about 30 minutes. When delime cycle is complete, DELIME light will appear, DONE light will flash and beeper will beep.

STEP 7- Press ON/OFF to turn steamer off. Let cavity cool for 5 minutes or longer. Open door, wipe out inside of cavity and wipe door gasket. Close door.

STEP 8- To use steamer, press ON/OFF. When READY light appears, steamer is ready to use.

NOTES:

- If DELIME light flashes rapidly (5 times per second), press CLEAN to restart delime cycle.
- If power outage occurs during delimiting, delime cycle must be restarted. Press CLEAN.
- For best performance, do not interrupt delime cycle. If delime cycle must be stopped, press ON/OFF to turn on. Set timer for 5 minutes. After beeper beeps, press ON/OFF to turn off. **Let cavity cool for 5 minutes or longer**, carefully open door(s) and wipe out cavity completely.

Maintenance

The HY-3E and HY-5E Steamers are designed for minimum maintenance, and no user adjustments should be necessary. Certain parts may need replacement after prolonged use. If there is a need for service, only authorized Groen Service Representatives should perform the work.

Always supply water with a low mineral count that meets the standards outlined in the **Water Conditioning** section of this manual.

If steam or condensate is seen leaking from around the door, take the following steps:

1. Check the door gasket. Replace it if it is cracked or split.
2. Inspect the cooking chamber drain to be sure it is not blocked.

3. Adjust the door latch pin to allow for changes that might occur as the gasket ages.
 - a. Loosen the lock nut at the base of the latch pin, then turn the latch pin ¼ turn clockwise, and tighten the lock nut.
 - b. After adjustment, run the unit to test for further steam leakage.
 - c. If there is still leakage, repeat the adjustment.
 - d. Continue adjusting the pin clockwise until the door fits tightly enough to prevent leakage.

Troubleshooting

This Groen Steamer is designed to operate smoothly and efficiently if properly maintained. However, the following is a list of checks to make in the event of a problem. Wiring diagrams are furnished inside the service panel. If an item on the check list is marked with (x), it means that the work should be done by a factory-authorized service representative.

SYMPTOM	WHO	WHAT TO CHECK
Steam generator does not fill with water.	User	a. Is the ON switch depressed? b. Is the water supply connected? c. Is the water turned on? d. Check for low water pressure (less than 30 PSI) or low water flow (less than 1.5 gpm). e. Is the screen at the water connection clogged? f. Has the steam generator been de-limed?
No steam.	User	a. Is the ON switch depressed? b. Is the water supply connected? c. Is the water turned on? d. Are steamer doors completely closed? e. Is the steam generator blocked with lime build-up?
DELIME light comes on after four minutes.	User	a. Is the water supply connected and adequate? b. Is the water turned on? c. Has the unit been de-limed? (Refer to Cleaning Section)
Excessive steam escaping from rear of unit	User	a. Is the water spray hose kinked or obstructed?
	Auth Service Rep Only	b. Is the water spray solenoid connected?(x) c. Is the drain properly vented? (x)