



## Cooker/Mixer models DL-40 INA/2, DL-60 INA/2 & DL-80 INA/2

### Description

Cooker Mixer Kettle shall be a Groen Model DL-40, 60, 80, INA/2 (Specify 40-, 60- or 80- gallon) stainless steel, self-contained, 2/3 steam jacketed unit operated from a direct steam source and complete with console mounted tilt-out inclined agitator mixer.

### Construction

Kettle interior shall be 316 stainless steel, solid one-piece welded construction. Kettle jacket shall be 304 stainless steel solid one-piece construction. Unit provided with a heavy-duty reinforced rim with a welded-in butterfly-shaped pouring lip for maximum sanitation and durability. Unit includes 10-gallon etch markings, double pantry faucet and steam regulating system.

Kettle to be tilting type with a positive locking worm and gear tilt mechanism enclosed in a polished, drip-proof stainless steel housing. Kettle mounted on a polished, stainless steel tri-leg stand with stainless steel floor flanges.

### Agitator Assembly

Agitator assembly to be designed to thoroughly fold and blend with gentle lifting action provided by the agitator, entering kettle body at an angle. Inclined agitator to be stainless steel tubular frame, complete with finger-type or shovel-type scrapers. Agitator to be readily removable for ease of cleaning and maximum sanitation.

Unit driven by a gear motor through an electronic variable-speed control. Motor is completely enclosed-type with a cast iron housing, helical bevel gearing and right angle shaft down. Motor drive is mounted on a stainless steel channel that manually hinges out to the back of kettle. Unit to be equipped with a spring assist for agitator tilt-out. A positive quick-acting lock and latch mechanism to be provided to secure the agitator when it is in the kettle.

### Finish

Kettle interior shall be polished to a 180 emery grit finish. Kettle exterior shall be finished to a bright semi-deluxe buff finish, ensuring maximum ease in cleaning and maintaining brilliant appearance.

### ASME Code

Unit shall be ASME shop-inspected, stamped and registered with the National Board for operation up to a maximum working pressure of 50 PSIG.

### Sanitation

Unit shall be designed and constructed to be NSF listed meeting NSF requirements.

### Drawoff

Bottom outlet to be 2" flush-mounted, sanitary quick opening ball valve.

Model DL-60, INA/2 shown



### Steam Pressure

Kettle shall operate dependably at any steam pressure of 50 PSIG or below (to a minimum of 5 PSIG). Higher working pressure available. The steam supply shall be injected directly into the jacket through the trunnion, and the condensate shall be removed through a tube contained in the jacket and connected to the opposite trunnion. No exposed steam piping or obstructions shall be on the kettle body.

### Controls

Agitator to be electronic, variable speed control-type capable of operating at any RPM between minimum and maximum settings.

### Installation

3/4" NPT steam inlet and condensate connection are provided. A remote steam source is required. A steam trap assembly with check valve and globe valve is provided as standard.

Unit requires agitator power connection, specify 208 Volt, (1 or 3-phase is standard). Other voltages are available.

### Options/Accessories

- 240, 480 Volt Power Supply (For agitator motor)
- Kettle Brush Kit
- Pan Carrier
- Wall Mount With In Wall Carrier
- Gallon Master
- Basket Insert
- Cold Water Cooling
- Working Pressure (higher or lower than 50 PSIG)
- Lip strainers
- Contour measuring strips

### Origin of Manufacture

Kettle, agitator assembly and motor shall be designed and manufactured in the United States.

## Stainless Steel 2/3 Steam Jacketed Cooker/Mixer

Floor-Mounted,  
Tilting,  
Direct Steam  
40, 60 or 80-  
Gallon Capacity  
with Inclined Agitator

### Short Form

GROEN Model DL-40, 60, 80 INA/2 (Specify gallons) stainless steel, tilting, steam jacketed cooker/mixer with tilt out inclined agitator. Kettle tilt mechanism to be positive locking worm and gear enclosed in drip-proof stainless steel housing. Patented agitator shaft assembly enters kettle at angle which causes scraper blades to lift product and uniformly blend and fold. Equipped with mechanically assisted tilt-out mechanism and positive, quick- action rim lock and latch. 316 stainless steel kettle interior has solid, one-piece, welded construction with heavy-duty reinforced rim and butterfly-shaped pouring lip. Unit standard with 2" flush-mounted ball valve, and etch marks. Kettle mounted on stainless steel tri-leg stand. ASME code-constructed and National Board-registered for operation up to 50 PSI and NSF listed. Specify 208 Volt (3 or 1-phase ) for agitator assembly electric connection. Made in USA.



### Applications

- Wet roasting meats
- Soups
- Stews
- Stocks
- Poultry
- Sauces
- Pie Fillings
- Vegetables
- Pasta
- Rice
- Gravies

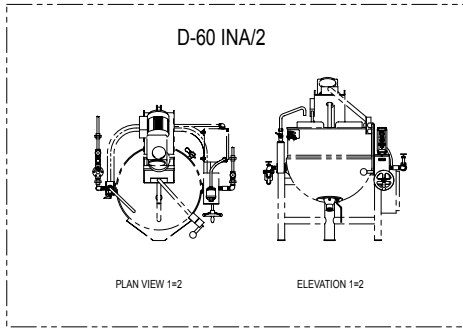

**NOTES:**

(DIM) ARE IN MM.

STEAM PIPING SHOWN ON PRINT ARE FOR REFERENCE ONLY. UNIT WILL BE SHIPPED WITHOUT PIPING INSTALLED.

**SERVICE CONNECTIONS:**

- 1: STEAM INLET 3/4" NPT
- 2: STEAM OUTLET 3/4" NPT
- 3: ELECTRICAL CONNECTION: (AGITATOR SUPPLY)  
1-1/8" DIA. HOLE  
(REF. 3/4" CONDUIT KNOCKOUT)  
208/60/1PH  
5.1 FULL LOAD AMPS
4. ALL PIPING TO BE INSTALLED BY PURCHASER.
5. COLD & HOT WATER SUPPLY.

| TABLE OF DIMENSIONS |            |      |            |      |            |
|---------------------|------------|------|------------|------|------------|
| MODEL               | D-40 INA/2 |      | D-60 INA/2 |      | D-80 INA/2 |
| CAPACITY            | 40 GAL.    |      | 60 GAL.    |      | 80 GAL.    |
| DIM.                | INCH       | MM   | INCH       | MM   | INCH       |
| A                   | 26         | 660  | 30         | 762  | 34         |
| B                   | 22         | 559  | 25         | 635  | 27         |
| C                   | 38         | 965  | 41         | 1041 | 43         |
| D                   | 25-1/2     | 648  | 26-1/2     | 673  | 27-1/2     |
| E                   | 12-1/2     | 318  | 11-1/2     | 292  | 10-1/2     |
| F                   | 9-1/2      | 241  | 8          | 203  | 7          |
| G                   | 56-1/2     | 1435 | 59-1/2     | 1511 | 61-1/2     |
| H                   | 69         | 1753 | 72         | 1829 | 74         |
| J                   | 45-1/16    | 1145 | 48-15/16   | 1243 | 52-13/16   |
| K                   | 20         | 508  | 22         | 559  | 24         |
| L                   | 17-1/16    | 433  | 18-15/16   | 481  | 20-13/16   |
| M                   | 18-5/8     | 473  | 20-5/8     | 524  | 22-5/8     |
| N                   | 22-3/8     | 568  | 24-3/8     | 619  | 26-3/8     |
| P                   | 41         | 1041 | 45         | 102  | 49         |
| Q                   | 15-3/8     | 391  | 17-3/8     | 441  | 19-3/8     |
| R                   | 30-3/4     | 781  | 34-3/4     | 883  | 38-3/4     |
| S                   | 12-1/2     | 318  | 14-3/4     | 375  | 16-3/4     |
| T                   | 38         | 965  | 40         | 1016 | 46         |
| APPROX. WEIGHT      |            | 615  |            | 670  | 740        |

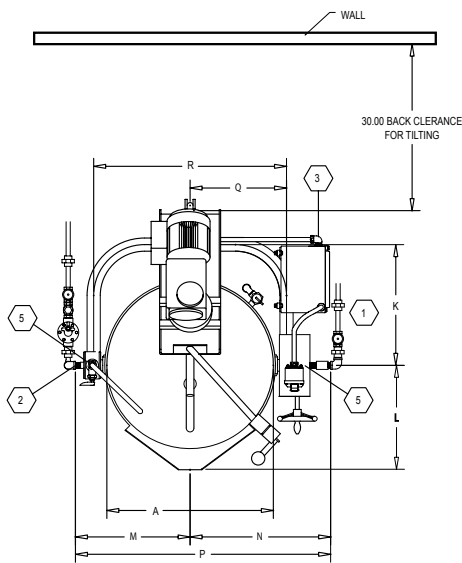

|        | AGITATOR MOTOR DATA SPECIFICATIONS |          |               | ELEC. LOAD RATING |          |          |        |
|--------|------------------------------------|----------|---------------|-------------------|----------|----------|--------|
|        | H.P.                               | RPM MAIN | RPM SECONDARY | 208V 3PH          | 240V 3PH | 480V 3PH |        |
| 40 GAL | MAXIMUM                            | 1-1/2    | 54            | 150               | 5 A      | 4.55 A   | 2.28 A |
|        | MINIMUM                            | 3/4      | 27            | 75                | 6.3 A    | 5.7 A    | 2.83 A |
| 60 GAL | MAXIMUM                            | 2        | 46            | 120               | 6.8 A    | 6 A      | 3 A    |
|        | MINIMUM                            | 1        | 23            | 60                | 4.7 A    | 4 A      | 2 A    |
| 80 GAL | MAXIMUM                            | 2        | 46            | 120               | 6.8 A    | 6 A      | 3 A    |
|        | MINIMUM                            | 1        | 23            | 60                | 4.7 A    | 4 A      | 2 A    |

