

OPERATOR MANUAL

Part Number 137920 Rev. B

OM-DHS

DOMESTIC

MODEL: DHS
Low Height Steam
Jacketed Kettle
[with Standard Electronic Ignition]

Self-Contained
Stainless Steel
Gas Heated
Floor Mounted
Tilting



THIS MANUAL MUST BE RETAINED FOR FUTURE REFERENCE. READ, UNDERSTAND AND FOLLOW THE INSTRUCTIONS AND WARNINGS CONTAINED IN THIS MANUAL.

FOR YOUR SAFETY

DO NOT STORE OR USE GASOLINE OR OTHER FLAMMABLE VAPORS AND LIQUIDS IN THE VICINITY OF THIS OR ANY OTHER APPLIANCE.

POST IN A PROMINENT LOCATION

INSTRUCTIONS TO BE FOLLOWED IN THE EVENT USER SMELLS GAS. THIS INFORMATION SHALL BE OBTAINED BY CONSULTING YOUR LOCAL GAS SUPPLIER. AS A MINIMUM, TURN OFF THE GAS AND CALL YOUR GAS COMPANY AND YOUR AUTHORIZED SERVICE AGENT. EVACUATE ALL PERSONNEL FROM THE AREA.

WARNING

IMPROPER INSTALLATION, ADJUSTMENT, ALTERATION, SERVICE OR MAINTENANCE CAN CAUSE PROPERTY DAMAGE, INJURY OR DEATH. READ THE INSTALLATION, OPERATING AND MAINTENANCE INSTRUCTIONS THOROUGHLY BEFORE INSTALLING OR SERVICING THIS EQUIPMENT.

IMPORTANT — READ FIRST — IMPORTANT

- WARNING:** FAILURE TO DISCONNECT POWER BEFORE SERVICING COULD RESULT IN ELECTROCUTION AND DEATH.
- WARNING:** IMPROPER INSTALLATION, ADJUSTMENT, ALTERATION, SERVICE OR MAINTENANCE CAN CAUSE PROPERTY DAMAGE, INJURY OR DEATH. READ THE INSTALLATION, OPERATING AND MAINTENANCE INSTRUCTIONS THOROUGHLY BEFORE INSTALLING OR SERVICING THIS EQUIPMENT.
- WARNING:** THE UNIT MUST BE INSTALLED BY PERSONNEL QUALIFIED TO WORK WITH GAS, ELECTRICITY AND PLUMBING. UNIT MUST BE INSTALLED IN ACCORDANCE WITH ALL APPLICABLE CODES.
- WARNING:** DO NOT ATTACH THE UNIT TO A TYPE "B" VENT. IT COULD CAUSE FIRE OR PROPERTY DAMAGE.
- WARNING:** DO NOT CONNECT ANY PIPING TO THE PRESSURE RELIEF VALVE. IT MUST BE FREE TO VENT STEAM AS NEEDED. TO AVOID BURNS FROM THE VENTED STEAM THE VALVE DISCHARGE SHOULD POINT DOWNWARD. IMPROPER INSTALLATION WILL VOID WARRANTY.
- DANGER:** ELECTRICALLY GROUND THE UNIT AT THE TERMINAL PROVIDED. FAILURE TO GROUND THE UNIT COULD RESULT IN ELECTROCUTION AND DEATH.
- CAUTION:** BE SURE ALL OPERATORS READ, UNDERSTAND AND FOLLOW THE OPERATING INSTRUCTIONS, CAUTIONS AND SAFETY INSTRUCTIONS CONTAINED IN THIS MANUAL.
- CAUTION:** DO NOT OVERFILL THE KETTLE WHEN COOKING, HOLDING OR CLEANING. KEEP LIQUIDS A MINIMUM OF 2-3" (5-8 CM) BELOW THE KETTLE BODY RIM TO ALLOW CLEARANCE FOR STIRRING, BOILING AND SAFE TRANSFER OF PRODUCT.
- CAUTION:** KEEP FLOORS IN FRONT OF KETTLE WORK AREA CLEAN AND DRY. IF SPILLS OCCUR, CLEAN IMMEDIATELY TO AVOID SLIPS OR FALLS.
- WARNING:** KEEP WATER AND SOLUTIONS OUT OF CONTROLS AND BURNERS. NEVER USE A HIGH PRESSURE HOSE TO CLEAN KETTLE SURFACES.
- CAUTION:** MOST CLEANERS ARE HARMFUL TO THE SKIN, EYES, MUCOUS MEMBRANES AND CLOTHING. TAKE PRECAUTIONS: WEAR RUBBER GLOVES, GOGGLES OR FACE SHIELD AND PROTECTIVE CLOTHING. CAREFULLY READ WARNINGS AND FOLLOW DIRECTIONS ON CLEANER LABELS .
- WARNING:** DO NOT STAND ON OR APPLY UNNECESSARY WEIGHT OR PRESSURE ON THE KETTLE FRONT OR POURING LIP. THIS COULD RESULT IN THE OVERLOAD AND FAILURE OF THE TILT MECHANISM, AND POSSIBLE SERIOUS INJURY AND BURNS TO THE OPERATOR AND OTHERS.
- NOTICE:** NEVER LEAVE A SANITIZER IN CONTACT WITH STAINLESS STEEL SURFACES LONGER THAN 10 MINUTES. LONGER CONTACT CAN CAUSE CORROSION.
- WARNING:** FAILURE TO PERIODICALLY CHECK PRESSURE RELIEF VALVE OPERATION COULD RESULT IN PERSONAL INJURY AND/OR DAMAGE TO EQUIPMENT.
- WARNING:** WHEN TESTING, AVOID EXPOSURE TO THE STEAM BLOWING OUT OF THE PRESSURE RELIEF VALVE. DIRECT CONTACT COULD RESULT IN SEVERE BURNS.
- WARNING:** TO AVOID INJURY, READ AND FOLLOW ALL PRECAUTIONS STATED ON THE LABEL OF THE WATER TREATMENT COMPOUND.
- WARNING:** BEFORE REPLACING ANY PARTS, DISCONNECT THE UNIT FROM THE ELECTRIC POWER SUPPLY AND CLOSE THE MAIN GAS VALVE. ALLOW FIVE MINUTES FOR GAS TO VENT.
- CAUTION:** USE OF ANY REPLACEMENT PARTS OTHER THAN THOSE SUPPLIED BY GROEN OR AUTHORIZED DISTRIBUTORS CAN CAUSE INJURY TO THE OPERATOR AND DAMAGE TO THE EQUIPMENT AND WILL VOID ALL WARRANTIES.
- WARNING:** KEEP AREA AROUND KETTLE FREE AND CLEAR OF ALL COMBUSTIBLE MATERIALS. FAILURE TO DO SO COULD RESULT IN FIRE OR PROPERTY DAMAGE.
- CAUTION:** HEATING AN EMPTY KETTLE MAY CAUSE THE RELEASE OF STEAM FROM THE PRESSURE RELIEF VALVE.
- IMPORTANT:** SERVICE PERFORMED BY OTHER THAN FACTORY AUTHORIZED PERSONNEL WILL VOID ALL WARRANTIES.

WARNING: THIS UNIT IS INTENDED FOR USE IN THE COMMERCIAL HEATING, COOKING AND HOLDING OF WATER AND FOOD PRODUCTS, PER THE INSTRUCTIONS CONTAINED IN THIS MANUAL. ANY OTHER USE COULD RESULT IN SERIOUS PERSONAL INJURY OR DAMAGE TO THE EQUIPMENT AND WILL VOID WARRANTY.

WARNING: AVOID ALL DIRECT CONTACT WITH HOT EQUIPMENT SURFACES. DIRECT SKIN CONTACT COULD RESULT IN SEVERE BURNS.

WARNING: AVOID ALL DIRECT CONTACT WITH HOT FOOD OR WATER IN THE KETTLE. DIRECT CONTACT COULD RESULT IN SEVERE BURNS.

WARNING: WHEN TILTING KETTLE FOR PRODUCT TRANSFER:

- 1) USE CONTAINER DEEP ENOUGH TO CONTAIN AND MINIMIZE SPLASHING.**
- 2) PLACE CONTAINER ON STABLE, FLAT SURFACE, AS CLOSE TO KETTLE AS POSSIBLE.**
- 3) DO NOT OVER FILL CONTAINER. AVOID DIRECT SKIN CONTACT WITH HOT CONTAINER AND ITS CONTENTS.**

Table of Contents

IMPORTANT OPERATOR WARNINGS 2

REFERENCES 4

EQUIPMENT DESCRIPTION 5

INSPECTION & UNPACKING 6

INSTALLATION & INITIAL START UP 7

OPERATION 9

SEQUENCE OF OPERATION 11

MAINTENANCE 12

CLEANING 15

TROUBLESHOOTING 17

PARTS LIST 19

ELECTRICAL SCHEMATIC 27

SERVICE LOG 28

WARRANTY 29

REFERENCES

CSA INTERNATIONAL
 8501 East Pleasant Valley Road
 Cleveland, Ohio 44131

AMERICAN NATIONAL STANDARDS INST.,INC
 1430 Broadway
 New York, New York 10018

NSF INTERNATIONAL
 789 N. Dixboro Rd.
 P.O. Box 130140
 Ann Arbor, Michigan 48113-0140

Z223.1-1984-National Fuel Gas Code
Z21.30 - Installation Gas Appliances & Piping

KLENZADE SALES CENTER ECOLAB, Inc.
 370 Wabasha
 St. Paul, Minnesota 55102

NATIONAL FIRE PROTECTION ASSOCIATION
 60 Battery March Park
 Quincy, Massachusetts 02269

ZEP MANUFACTURING COMPANY
 1310-T Seaboard Industrial Boulevard
 Atlanta, Georgia 30318

NFPA/54-Installation Gas Appliances & Piping
NFPA/70-The National Electric Code

Equipment Description

The Groen DHS is a floor-mounted, tilting, steam jacketed kettle with a thermostatically controlled, self-contained, gas-heated steam source and appropriate controls, mounted on a sturdy base. The Model DHS is available in 40 gallon capacities.

The body of the DHS Kettle is constructed of stainless steel, welded into one solid piece. The kettle is furnished with a reinforced rim and a butterfly shaped pouring lip. It has a steam jacket which is ASME shop inspected and registered with the national board for working pressures up to 50 PSI. Kettle finish is 180 emery grit on the inside and bright high buff polish on the outside.

The kettle is tilted with a hand crank to pour out its contents. Stainless steel panels enclose the controls and the base. Four stainless steel tubular legs support the unit. Bullet feet on

each of the legs can be adjusted to level the kettle. Standard DHT units include a two inch tangent draw-off valve.

The self-contained steam source is heated by propane or natural gas. Electronic spark to pilot ignition is standard for all units.

The kettle is filled at the factory with water which contains rust inhibitors. The steam source provides kettle temperatures of 150° to approximately 295°F (65 to 150°C). Unit controls include a thermostat, pressure gauge, safety valve, pressure limit control, low water cut-off, power switch and gas regulator valve. The gas supply shuts off automatically when the kettle is tilted.

The unit must be specified for use with natural or propane gas. Service connections for gas and electricity are required. Standard power supply is 115 Volt.

KETTLE CHARACTERISTICS		
	DHS-40	DHS/T-40
Kettle Capacity	40 gal. (150 ltr)	40 gal. (150 ltr)
Tangent drawoff	No	Yes
Jacket Capacity	14 gal. (53 ltr)	14 gal. (53 ltr)
Kettle Body Diameter	30 in. (762 mcm)	30 in. (762 mm)
Base Width	47 in. (1194 mm)	47 in. (1194 mm)
Base Front to Back	29 (736 mm)	29 (736 mm)
Firing Rate - per hour	150,000 BTU	150,000 BTU
Energy into Product per hr.	82,000 BTU	82,000 BTU

Options available with listed models are:

1. Two inch tangent drawoff*
2. Strainers, solid disk (P/N 013783), ¼" (P/N 009944) or C" perforations (P/N 13785).
3. No. 31 lift-off cover(P/N 001116)
4. No. 51 counterbalanced cover w/actuator*
5. Basket Inserts (Tri-BC)
6. Water fill faucets with swing spout (P/N 009054)
7. Kettle Brush Kit (P/N 104278)
8. 316 Stainless steel interior* (Must be indicated on initial order)
9. Gallon etch marks*
10. Automatic, metered water filler.
11. Powerd agitators (TA/3 or INA/2)*

* Factory-installed options

Inspection & Unpacking

The unit will arrive in a heavy shipping carton and will be bolted or banded to a skid. Immediately upon receipt, inspect the carton carefully for exterior damage.

CAUTION
SHIPPING STRAPS ARE UNDER TENSION AND CAN SNAP BACK WHEN CUT. TAKE CARE TO AVOID PERSONAL INJURY OR DAMAGE TO THE UNIT BY STAPLES LEFT IN THE WALLS OF THE CARTON.

Carefully cut any polyester straps around the carton and detach the sides of the box from the skid. Pull the carton up off the unit.

Thoroughly inspect the unit for hidden damage. Report any shipping damage or incorrect shipments to the delivery agent.

Write down the model number, serial number, and installation date, and retain this information for future reference. Space for these entries is provided at the top of the Service Log at the back of this manual. Keep this manual on file and available for operators to use.

CAUTION
THIS UNIT WEIGHS BETWEEN 535 AND 880 POUNDS (245 TO 400 Kg) DEPENDING ON SIZE. INSTALLER SHOULD USE PROPER EQUIPMENT TO LIFT SAFELY.

When installation is to begin, carefully cut any straps which hold the unit on the skid. Lift the unit straight up off the skid. Examine packing materials to be sure loose parts are not discarded with the materials.



Installation & Initial Start-Up

For efficient performance the DH kettle must be installed in a well-ventilated area. Items which might restrict or obstruct the flow of air for combustion and ventilation must be removed. The area directly around the appliance must be free of combustible materials.

WARNING
THE KETTLE MUST BE INSTALLED BY PERSONNEL QUALIFIED TO WORK WITH ELECTRICITY AND PLUMBING. IMPROPER INSTALLATION CAN RESULT IN INJURY TO PERSONNEL AND/OR DAMAGE TO EQUIPMENT.

1. Installation on combustible floors is allowed. Rear clearance of 10 inches and two inches at both sides is required for both combustible and non-combustible construction. A 10" clearance or access on the right side is recommended for service.
2. The installation must conform with local codes or the American National Standards Z223.1- (current edition) National Fuel Gas Code. The kettle should be installed in an adequately ventilated room with provision for adequate air supply. The ventilation employ must employ a vent hood and exhaust fan with no direct connection between the vent duct and the kettle flue. Do not obstruct the flue or vent duct after installation.
3. Set the kettle in place and level it using a spirit level on the bar rim, by turning the bullet feet to adjust leg length. Allow clearance around the unit for cleaning, maintenance and service.

Clearances For DHS-40

	Required	Recommended
Left Side	6"	6"
Right Side	6"	10" (for service)
Rear	10"	10" (for tilting)

4. Complete the piping to the gas service main with ½" line or approved equivalent.
5. For standard units, provide 115 vac, 60 Hz, single phase 5 AMP electrical service. Local codes and/or The National Electrical Code should be observed in accordance with ANSI/NFPA 70 - (current edition). Use the wiring diagram inside the service panel and in this manual.
6. Bring electrical service through the entrance at the rear of the support housing with a ½ inch

conduit connector. Make a watertight connection with the incoming lines, utilizing the water resistant conduit fitting provided on the unit.

DANGER
ELECTRICALLY GROUND THE UNIT AT THE TERMINAL PROVIDED. FAILURE TO GROUND UNIT COULD RESULT IN ELECTROCUTION AND DEATH.

7. Electrically ground the unit at the terminal provided.



The open end of the pop safety valve elbow must face downward.

8. After the kettle has been connected to the gas supply, check all gas joints for leaks. **DO NOT USE FLAME TO CHECK FOR LEAKS.** A thick soap solution or electronic gas leak detector should be employed.
9. **PRESSURE TEST WARNING**
 - a) Test pressure exceeding ½ PSIG (3.45kPa). During pressure testing of the gas supply piping system at pressures exceeding ½ , the appliance and its individual shutoff valve Must be disconnected from the gas supply
 - b) Test pressure equal to or less than ½ PSIG (3.45kPa.) During pressure testing of the gas supply piping system at pressures equal to or less than ½ PSIG, the kettle must be isolated from the gas supply piping system by closing its individual manual shutoff valve.
10. Make sure the water level is correct in the jacket, by confirming that the level is near the middle of the sight glass. If the water level is low, follow the instructions in Jacket Filling and Water Treatment in the maintenance section of this manual.

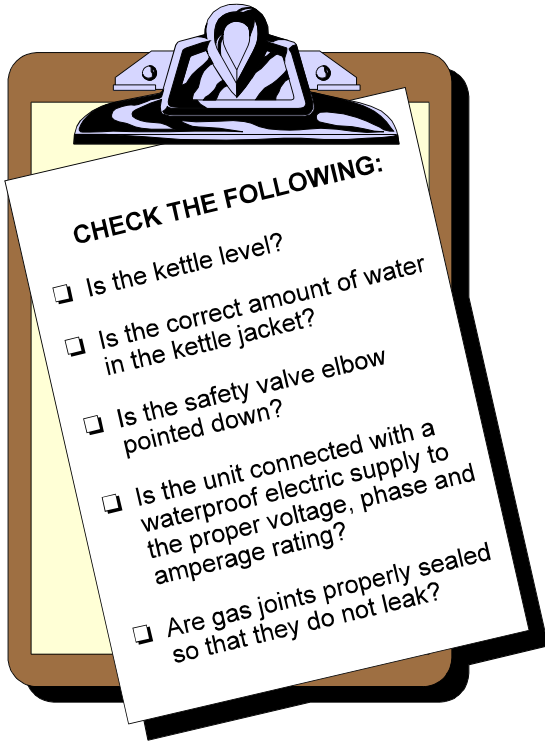

Now that the kettle has been installed, you should test to ensure that it is operating correctly.

1. Remove literature and packing materials from inside and outside of the unit.
2. If the unit is equipped with a draw-off valve (product outlet), clean out any material which might clog or damage the draw-off.
3. Confirm that the tilting mechanism is operating properly by tilting the kettle through its full range. Then return the kettle to the upright position.
4. Turn on the electrical service to the unit.
5. Pour 1-2 quarts of water into the kettle.
6. Following "To Start Kettle" instructions in the "Operation" section (Page 9), begin heating the water at the highest thermostat setting. The heat indicator light should come on, and heating should continue until the water boils.

11. The open end of the elbow on the outlet of the pressure relief valve must face downward. If it does not, turn it to the correct position.

If the unit functions as described it is ready for use. If it does not function as described, contact your local Groen Certified Service Agency.

WARNING

DO NOT CONNECT ANY PIPING TO THE PRESSURE RELIEF VALVE. THE VALVE MUST BE FREE TO VENT STEAM AS NEEDED. IMPROPER INSTALLATION WILL VOID THE WARRANTY! THE ELBOW ATTACHED TO THE SAFETY VALVE MUST POINT TO THE FLOOR.

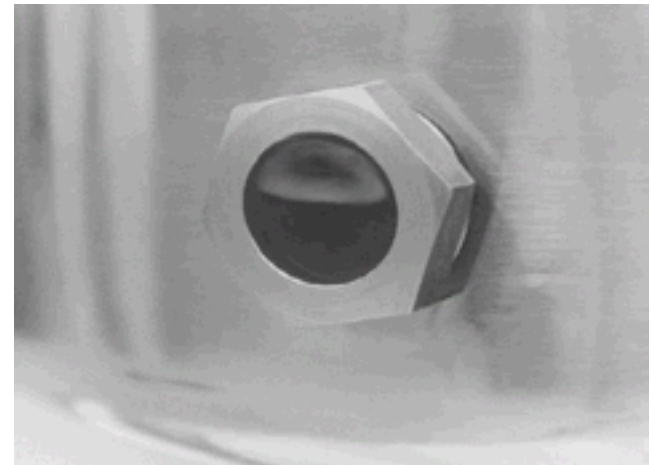

Correct Water Level

12. (For units with optional tangent draw-off). Assemble the tangent draw-off by placing the large nut over the draw-off valve and inserting it into the draw-off tube. ONLY HAND-TIGHTEN THE NUT to complete installation.



When attaching the draw-off valve hand-tighten the nut.

WARNING

DO NOT STAND ON OR APPLY UNNECESSARY WEIGHT OR PRESSURE ON THE KETTLE FRONT OR POURING LIP. THIS COULD RESULT IN THE OVERLOAD AND FAILURE OF THE TILT MECHANISM, AND POSSIBLE SERIOUS INJURY AND BURNS TO THE OPERATOR AND OTHERS.

Operation

A. Controls

Operator controls for the DHS kettle are:

1. Manual gas valve (on gas line behind the unit), which controls the supply of gas from the main to the unit.
2. On-Off (Toggle) Switch. This controls the supply of electric power to the control circuits.
3. Thermostat dial, which turns the thermostat on or off, and sets the kettle temperature.
4. Tilting crank, used to tilt the kettle body.
5. Indicator Lights to alert operator of unit conditions:
 - a. Power On Indicator - shows that the unit is turned on
 - b. Heat Indicator - indicates that main gas is on to produce steam in the kettle jacket.
 - c. Low Water indicator - shows that jacket water is low
6. Unit gas pressure regulator adjustment - located behind the access door in the kettle skirt.



- f. Turn thermostat to desired setting. The main gas burner will ignite, and will cycle to maintain the set temperature. The heat indicator light will come on.
- g. If the unit does not light, turn it off and wait five minutes. Then follow the instructions again.

B. Operating Instructions

1. To Start Kettle Heating:

- a. EVERY DAY make sure that the jacket water level in the middle of the sight glass. If the level is too low, see "Jacket Filling and Water Treatment" on page 13.
- b. Check the pressure/vacuum gauge. If the gauge does not show 20 to 30 inches of mercury (Hg) vacuum (that is a reading of 20 to 30 below 0 atmospheric pressure), see "Jacket Vacuum" on page 13.
- c. Do not attempt to light any burner with a flame.
- d. Turn the manual gas valve ON (align handle with gas line).
- e. Turn toggle (on-off) switch ON. The electronic ignition will attempt to light the pilot for 90 seconds, or until it is lit. Once lit proceed to step two.

2. To Empty Kettle Or To Transfer Product:

- a. To tilt the body of the kettle forward, turn the hand crank on the front of the cabinet counter-clockwise. The body will stay in the position it holds when you stop cranking. To return the kettle body to its upright position, turn the crank clockwise.
- b. Product may also be transferred by means of the optional draw-off valve, if the kettle is so equipped.

3. To Stop Kettle Heating:

- a. Turn thermostat dial to OFF.
- b. Turn toggle switch to OFF.
- c. For a prolonged shut-down:
 1. Follow the procedure above.
 2. Turn the manual gas valve off (handle at right angles to gas line).

OM-DHS

3. Disconnect electric power from the unit.



WARNING

WHEN TILTING KETTLE:

- 1) WEAR PROTECTIVE OVEN MITT AND PROTECTIVE APRON.
- 2) USE DEEP CONTAINER TO CONTAIN AND MINIMIZE PRODUCT SPLASHING.
- 3) PLACE CONTAINER ON STABLE, FLAT SURFACE, AS CLOSE TO KETTLE AS POSSIBLE.
- 4) STAND TO RIGHT OF KETTLE WHILE POURING — NOT DIRECTLY IN POUR PATH OF HOT CONTENTS.
- 5) POUR SLOWLY, MAINTAINING CONTROL OF KETTLE, AND RETURN KETTLE BODY TO UPRIGHT POSITION AFTER CONTAINER IS FILLED OR TRANSFER IS COMPLETE.
- 6) DO NOT OVERFILL CONTAINER. AVOID SKIN CONTACT WITH HOT CONTAINER AND ITS CONTENTS.

4. To Relight Kettle

- a. Close main gas supply valve.
- b. Set on-off switch to OFF.
- c. Set thermostat to OFF.
- d. Wait five minutes, then proceed as directed under To Start Kettle Heating.

5. If Power Fails:

- a. Do not attempt to operate the unit until electric power is restored.
- b. When power comes back on, follow directions "To Start Kettle," above.

C. Use of Common Accessories

1. Lift-Off or Counterbalanced Cover

As with stock pot cooking, an optional cover can speed up the heating of water and food products. It helps retain heat and reduces the heat and humidity in the kitchen. A cover can reduce some product cook times and help maintain the

temperature, color and texture of products held or simmered for longer periods.

Be sure the handle is secure on the lift-off cover before using. ALWAYS use the handle to place or remove cover from the kettle. Wear protective oven mitts and apron

When putting a lift-off cover on the kettle, position it on top of kettle rim, with its flat edge facing the pouring lip.

WARNING

AVOID ALL DIRECT CONTACT WITH HOT SURFACES AND HOT FOOD OR WATER IN THE KETTLE. DIRECT CONTACT COULD RESULT IN SEVERE BURNS.

When removing a lift-off cover:

- a. Firmly grasp the handle, and lift the rear edge (farthest from operator) 1-2" (3-5 cm) to allow steam and water vapor to escape. Wait 2-3 seconds.
- b. Tilt cover to 45-60° angle to allow any hot condensate or product to roll off cover back into kettle.
- c. Remove cover, ensuring that remaining hot condensate or product does not drip on operator, floor or work surfaces.
- d. Place cover on safe, flat, sanitary, out-of-the-way surface, or return to kettle.

CAUTION

DO NOT TILT KETTLE WITH LIFT-OFF COVER IN PLACE. COVER MAY SLIDE OFF, CAUSING INJURY TO OPERATOR.

2. Basket Insert

An optional kettle basket insert set (Tri-BC) will assist in cooking water-boiled products including eggs, potatoes, vegetables, shell fish, pasta and rice. The nylon mesh liner must be used for products smaller than the basket mesh size, (approx. ¼" (6 mm)). This includes rice and small pasta shapes.

- a. Allow for displacement of the three baskets and product. This may mean only half filling the kettle. Test baskets and product displacement with the kettle OFF, and with cold water in the kettle.

CAUTION
DO NOT OVERFILL THE KETTLE WHEN COOKING, HOLDING OR CLEANING. KEEP LIQUIDS AT LEAST 2-3" (5-8 cm) BELOW THE KETTLE RIM TO ALLOW CLEARANCE FOR STIRRING, BOILING AND SAFE PRODUCT TRANSFER.

WARNING
AVOID ALL DIRECT CONTACT WITH HOT FOOD OR WATER IN THE KETTLE. DIRECT CONTACT COULD RESULT IN SEVERE BURNS.

- b. Load baskets on a level, stable work surface.
- c. Lift loaded baskets with both hands. Get help from another person if the basket is too heavy for safe handling.
- d. Slowly lower product into kettle and securely hook basket to the "Y" frame.
- e. When removing baskets with cooked product, lift straight up, ensuring basket bottoms clear the kettle rim and pouring lip. Wear protective oven mitts and protective apron.
- f. Allow hot water to fully drain from product, before moving basket away from the kettle. Do not rest baskets on kettle rim or pouring lip. If baskets are too heavy for individual to lift and safely move, get help. Remove product immediately from basket into another container, being sure to avoid contact with hot product and hot basket or...
- g. Place baskets with food on a stable, flat surface, inside a solid steamer or bake pan, to catch any remaining hot water draining from product.

Sequence of Operation

The following "action-reaction" outline is provided to help understand how the DHS kettle works.

1. When the power switch is turned on, it starts the spark igniter and opens the automatic valve for the pilot burner. The spark ignites a pilot flame, which heats the sensor. The sensor then sends a signal to turn off the spark. The flame

thereafter acts as a standing pilot until the power is turned off.

2. If the pilot flame is not sensed within 90 seconds after spark begins, a timer shuts down the entire operation. To attempt a second trial for ignition, turn off the power switch. Check the gas supply valves and wait five minutes before trying again by switching power on. If you cannot establish a pilot flame in four tries, close all valves, turn off the power, and contact an authorized Groen Service Agency.
3. When the operator sets a temperature on the thermostat, it causes the automatic valve to admit gas to the main burner, where it is ignited by the pilot flame. When the kettle reaches the set temperature, the thermostat switch opens. This stops the signal to the gas control valve and shuts off gas to the main burner. The pilot flame remains lit. When the kettle cools below the set temperature, the thermostat switch closes and starts another cycle. On and off cycling continues and maintains the kettle at the desired temperature. This action is indicated by the Heat indicator light.

The kettle has the following safety features in addition to the 90-second ignition timer:

1. Low water cutoff relay that will shut off gas supplies to all burners until the jacket water level is corrected.
2. High limit pressure switch, set to open at about 46 PSI and to shut down the burners until jacket pressure is decreased.
3. Pressure relief valve, which will release steam if jacket pressure exceeds 50 PSI.
4. Tilt switch, which shuts off all burners when the kettle is tilted.
5. Gas pressure regulator built into the gas control valve.

Maintenance

NOTICE: Contact Groen or an authorized Groen Service Agent when repairs are required.

1. Periodic Maintenance

A service Log is provided at the back of this manual with the warranty information. Each time maintenance is performed on your Groen kettle, enter the date on which the work was done, what was done, and who did it. Keep this manual on file and available for operators to use.

Periodic inspection will minimize equipment down time and increase the efficiency of operation. The following points should be checked:



The pressure gauge should show a vacuum of 20 to 30 inches when the kettle is cold.

- a. Check the pressure/vacuum gauge every day. The gauge should show a vacuum of 20 to 30 inches mercury (Hg), when the kettle is cold. If it does not, see “Jacket Vacuum” on page 13.
- b. Also check the jacket water level every day. It should be in the middle of the sight glass. If the level is low, see “Jacket Filling and Water Treatment” on page 13.
- c. Carefully test the pressure relief valve at least twice each month. With the kettle operating at five psi (105 kPa), pull the test lever and let it snap back to its closed position. If there is little discharge (mostly air), and the pressure gauge drops back to zero PSI, allow the pressure to build back to five PSI and repeat the procedure. (**Tip:** Using a screwdriver or other implement to pull the ring will help you avoid contact with the steam.)
- d. If the valve does not activate, or there is no evidence of discharge, or the valve leaks, stop

using the kettle and contact a qualified Groen service representative.



WARNING
WHEN TESTING, AVOID ANY EXPOSURE TO THE STEAM BLOWING OUT OF THE SAFETY VALVE. DIRECT CONTACT COULD RESULT IN SEVERE BURNS.

- e. Keep the primary burner gas jet air inlets free of dust and lint.
- f. The pilot flame should be blue. It should envelop about ½ inch (12 mm) of the flame sensor tip.
- g. The gear housing has fittings for lubrication of moving parts. The gears do not run in oil, so periodic lubrication with grease is necessary.
- h. Frequency of lubrication depends on operating conditions, but it should be done at least once every six months.
- i. Use a #2 grade LGI lithium grease to add grease through Zerk fittings on gear housing until it flows out of the bearings around the trunnion shaft.

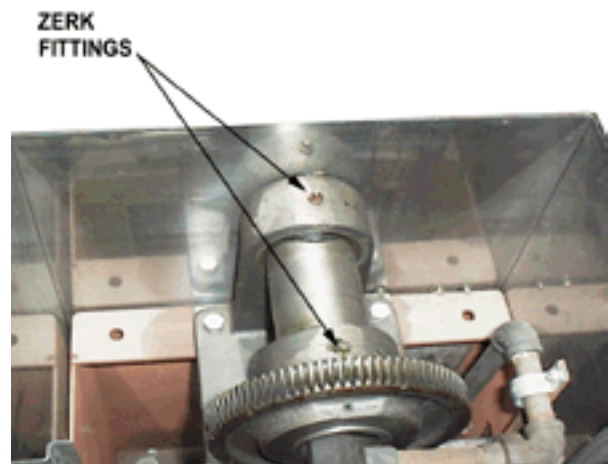

Add grease through Zerk Fittings.

- j. Place liberal amounts of grease on the gear to cover the arc that is in contact with the worm gear.

Packaging - Processing
Bid on Equipment
 1-847-683-7720
 www.bid-on-equipment.com

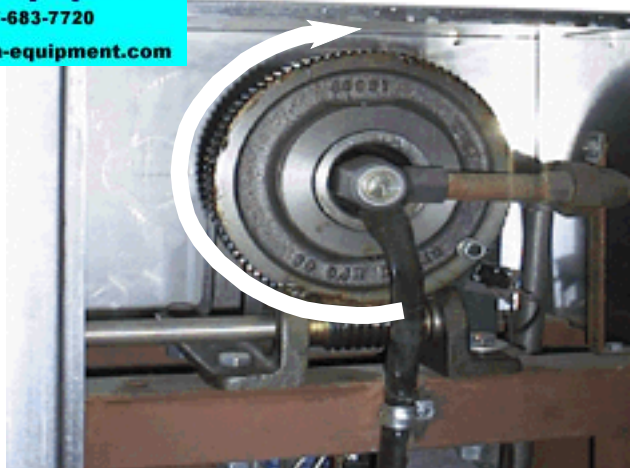

Liberal grease the wheel where it contacts the worm gear.

- k. Keep electrical wiring and connections in good condition.
- l. Keep the inside of the control console clean and dry.
- m. Keep burner slots clean.

2. Jacket Vacuum/Removing Air from Jacket

When the kettle is cold, a positive pressure reading on the pressure/vacuum gauge or a reading near zero indicates that there is air in the jacket. Air in the jacket acts as an insulator, and slows kettle heating.

To remove air:

- Start the unit. (Be sure there is water or product in the kettle when heating).
- When the pressure/vacuum gauge reaches a positive pressure reading of five PSI, release the trapped air and steam by pulling up the safety valve ring for about five seconds. Repeat this step three or four times. Then let the pull ring snap back into the closed position.
- If there is little discharge (mostly air), and the pressure gauge drops back to zero PSI, allow the pressure to build back to five PSI and repeat the procedure.
- Once steam has been vented from the jacket as described in b, above, remove the hot water from the kettle and replace it with cold. This will condense steam in the kettle jacket,

and the pressure gauge should show a reading of 20 to 30 inches mercury (Hg) below zero. If it does not, or if the vacuum is leaking down, contact a Groen authorized service agency to correct the problem.

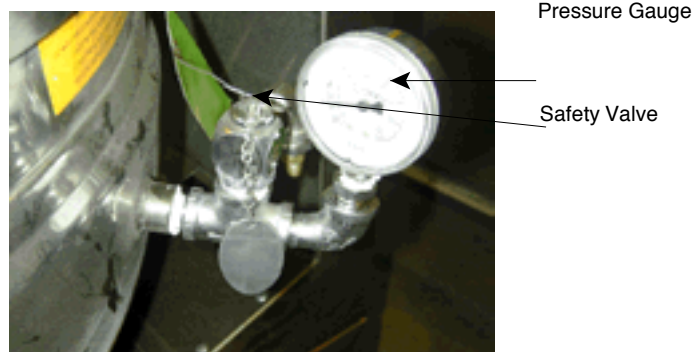

3. Jacket Filling and Water Treatment

The jacket was charged at the factory with the proper amount of treated water. You may need to restore this water, either because it was lost as venting steam or by draining. If you are replacing water lost as steam, use distilled water. If you are replacing treated water that ran out of the jacket, prepare more treated water as directed in "Water Treatment Procedure," below.

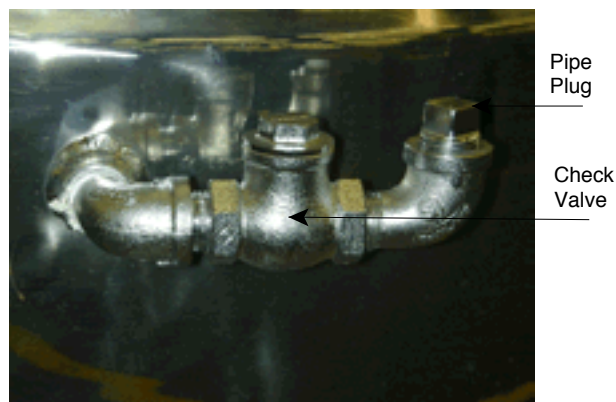

Test the safety valve at least twice monthly.

- Allow the kettle to cool completely. The procedure will be easier with the kettle under vacuum (pressure gauge reading below zero).
- Remove the pipe plug from the jacket fill assembly. Pour in the distilled or treated water. Using a funnel will help you in this process. Hold the pressure relief valve open while you pour, to let air escape from the jacket. Continue adding water until the water level rises to the center of the round sight glass.

OM-DHS

- c. Position a funnel in the opening and fill it with properly treated water.
- d. Air that gets into the jacket during the filling operation must be removed, because it will make heating less efficient. Follow the procedure in **Jacket Vacuum/Removing Air From Jacket** above, to restore a negative pressure reading.

4. Water Treatment Procedure

- a. Obtain water treatment compound and a pH test kit from your Groen Service Agent.

WARNING
TO AVOID INJURY, READ AND FOLLOW ALL PRECAUTIONS ON THE LABEL OF THE WATER TREATMENT COMPOUND.

- b. Fill a mixing container with the measured amount of water required. (See table). Distilled water is recommended.

Kettle Model	Approximate Jacket Capacity
DHS-40, DHS/T-40	4 Gallons

- c. Hang a strip of pH test paper on the rim of the container, with about 1 inch of the strip below the surface of the water.
- d. Measure the water treatment compound. One way to do this is to add the compound from a measuring cup.
- e. Stir the water continuously, while you slowly add treatment compound, until the water has a pH between 10.5 and 11.5. Judge the pH by frequently comparing the test strip color with the color chart provided in the test kit.
Caution: Do not add excess amount of treatment compound. Excess amount could cause extensive corrosion.
- f. As you add water to the jacket, check water level to ensure that it is in the middle of the sight glass
- g. Record the exact amounts of water and treatment compound needed. These amounts may be used again, if the same water sources and compound are used. However, it is best to check the pH each time treated water is prepared.

5. Component Replacement

WARNING
BEFORE REPLACING ANY PARTS, DISCONNECT THE UNIT FROM THE ELECTRIC POWER SUPPLY AND CLOSE THE MAIN GAS VALVE. ALLOW FIVE MINUTES FOR UNBURNED GAS TO VENT.

When component replacement involves breaking a gas pipe connection, check the new connection with soap solution or an appropriate leak detector. **DO NOT USE A FLAME TO TEST FOR LEAKS.**

Internal wiring is marked as shown on the circuit schematic drawings (inside control housing and in this manual). Be sure that new components are wired in the same manner as old components. An examination of the circuit schematic shows that the safety components are wired in series. In most cases, a faulty component may be isolated with a jumper wire to verify that the component is faulty. If this determination is made, contact a certified Groen Service Agency for assistance.

Cleaning

1. Suggested Cleaning Supplies:

- Cleaner, such as Klenzade HC-10 or HC-32 from ECOLAB, Inc.
- Kettle brushes in good condition
- Sanitizer such as Klenzade XY-12.
- Film remover such as Klenzade LC-30.
- Groen Sray Degreaser (P/N 114801)
- Groen Delimer/Descaler (P/N 114800)

2. Precautions

Before cleaning, shut off the kettle by turning the thermostat dial to "OFF," and shut off all electric power to the unit at a remote switch, such as the circuit breaker.

WARNING
KEEP WATER AND SOLUTIONS AWAY FROM CONTROLS AND ELECTRICAL EQUIPMENT. NEVER SPRAY THE SUPPORT HOUSING OR ELECTRICAL CONNECTIONS.



CAUTION
MOST CLEANERS ARE HARMFUL TO THE SKIN, EYES, MUCOUS MEMBRANES, AND CLOTHING. PRECAUTIONS SHOULD BE TAKEN. WEAR RUBBER GLOVES, GOGGLES OR FACE SHIELD, AND PROTECTIVE CLOTHING. READ THE WARNINGS AND FOLLOW THE DIRECTIONS ON THE LABEL OF THE CLEANER CAREFULLY

3. Procedure

- Clean food-contact surfaces as soon as possible after use. If the unit is in continuous use, thoroughly clean and sanitize the interior and exterior at least once every 12 hours.
- Scrape and flush out food residues. Be careful not to scratch the kettle with metal implements. (For DHS/T models only: After flushing the kettle, close the draw-off valve.)

CAUTION
NEVER LEAVE A SANITIZER IN CONTACT WITH STAINLESS STEEL SURFACES LONGER THAN 30 MINUTES. LONGER CONTACT CAN CAUSE CORROSION.

- Prepare a hot solution of the detergent/cleaning compound as instructed by the supplier. Clean the unit thoroughly. A cloth moistened with cleaning solution can be used to clean controls, housings, and electrical conduits.
- Model DHT only: Disassemble the tangent draw-off valve. Clean the draw-off port and each valve part with a brush.

CAUTION
DO NOT MIX PARTS OF DIFFERENT DRAW-OFF VALVE ASSEMBLIES. THE PARTS ARE NOT INTERCHANGEABLE.

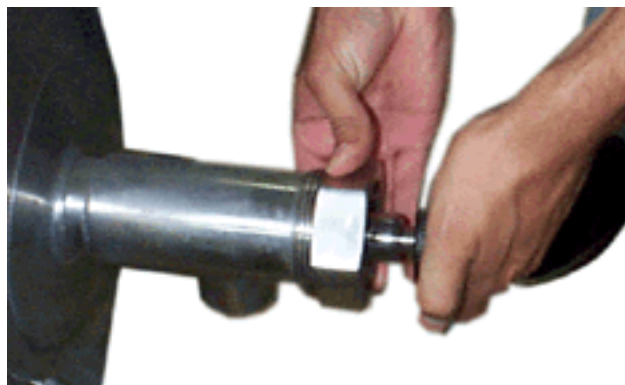

When attaching the draw-off valve, just hand-tighten the nut.

- Rinse the kettle and draw-off valve parts thoroughly with hot water, then drain completely.
- When you reassemble the draw-off valve, hand-tighten the nut which holds it in place.
- As part of the daily cleaning program, clean soiled external and internal surfaces. Remember to check the sides of the unit and control housing, underside of cover, etc.
- To remove burnt on foods, use a brush, sponge, cloth, plastic or rubber scraper, or plastic wool with the cleaning solution. To reduce effort required in washing, let the detergent solution sit in the kettle and soak into the residue. Do NOT use abrasive materials or metal tools that might scratch the surface. Scratches make the surface harder to clean and provide places for bacteria to grow.

Do NOT use steel wool, which may leave particles in the surface and cause eventual corrosion and pitting.

OM-DHS

- i. The outside of the unit may be polished with a stainless steel cleaner such as “Zepper” from Zep Manufacturing Co.
- j. When equipment needs to be sanitized, use a solution equivalent to one that supplies 200 parts per million available chlorine. Obtain advice on sanitizing agents from your supplier of sanitizing products.
- k. Following the supplier’s instructions, apply the agent after the unit has been cleaned and drained. Rinse off the sanitizer thoroughly.

NOTICE
NEVER LEAVE A CHLORINE SANITIZER IN CONTACT WITH STAINLESS STEEL SURFACES LONGER THAN 30 MINUTES. LONGER CONTACT CAN CAUSE STAINING AND CORROSION.

- k. It is recommended that each piece of equipment be sanitized just before use.
- l. If there is difficulty removing mineral deposits or a film left by hard water or food residues, clean the kettle thoroughly and then use a deliming agent, like Groen Delimer/Descaler (Part Number 114800) or Lime-Away from Ecolab, in accordance with the manufacturer’s directions. Rinse and drain the unit before further use.
- m. If cleaning problems persist, contact your cleaning product representative for assistance. The supplier has a trained technical staff with laboratory facilities to serve you.

Troubleshooting

Your Groen kettle is designed to operate smoothly and efficiently if properly maintained. However, the following is a list of checks to make in the event of a problem. Wiring diagrams are furnished inside the service panel and in this manual. **If an item on the list is followed by ✕, the work should be done by a qualified service representative.**

WARNING		
BEFORE REPLACING ANY PARTS, DISCONNECT THE UNIT FROM THE ELECTRIC POWER SUPPLY AND CLOSE THE MAIN GAS VALVE. ALLOW FIVE MINUTES FOR UNBURNED GAS TO VENT.		
CAUTION		
USEING REPLACEMENT PARTS OTHER THAN THOSE SUPPLIED BY GROEN OR THEIR AUTHORIZED DISTRIBUTOR CAN CAUSE OPERATOR INJURY AND EQUIPMENT DAMAGE AND WILL VOID ALL WARRANTIES.		
SYMPTOM	WHO	WHAT TO CHECK ✕ indicates items which must be performed by an authorized technician.
Kettle is hard to tilt.	User	a. Gears for foreign materials, and lubrication.
	Auth Service Rep Only	b. Gears for alignment. ✕ c. Worm gears or broken gears. ✕
Kettle continues heating after it reaches desired temperature.	User	a. Thermostat dial setting.
	Auth Service Rep Only	b. Thermostat calibration. ✕ c. Thermostat operation. The thermostat should click when the dial is rotated to settings above and below the temperature of the kettle. ✕
Kettle stops heating before it reaches the desired temperature.	User	a. Thermostat dial setting.
	Auth Service Rep Only	b. Thermostat calibration. ✕ c. Thermostat operation. The thermostat should click when the dial is rotated to settings above and below the temperature of the kettle. ✕
Pressure relief valve pops open	User	a. For air in the jacket. See "Jacket Vacuum" in the Maintenance section. b. Thermostat dial setting.
	Auth Service Rep Only	c. For defective thermostat. The thermostat should click when the dial is rotated to settings above and below the temperature of the kettle. If defective, replace. ✕ d. For defective pressure relief valve. If the valve pops at pressures below 49 PSI, replace. ✕
Burners will not light.	User	a. That the main gas supply valve is open. (handle is in line with gas pipe). b. Gas supply to the building. c. That the kettle body is not tilted.
	Auth Service Rep Only	d. Thermostat operation. The thermostat should click when the dial is rotated to settings above and below the temperature of the kettle. ✕ f. That tilt limit switch is closed when body is not tilted. ✕
System does not produce a spark	Auth Service Rep Only	a. Thermostat, and close the contacts if they are open ✕ b. AC voltage between terminals on secondary side of transformer. If it is not 24 Volt, replace the transformer ✕ c. That the high tension cable is firmly attached and in good condition. If cracked or brittle, replace. ✕ d. Pilot electric ceramic for crack or break. ✕ e. Pilot spark gap. Regap. ✕
Pressure relief valve leaks a small amount of steam when the kettle is operating.	User	a. For contamination that prevents seating of valve. With full pressure in the jacket, pull the lever all the way briefly to blow the valve clean, then let the lever snap back to seat the valve.
	Auth Service Rep Only	b. Pressure relief valve for defects. Replace any defective valve with an identical valve. ✕
Kettle is hard to tilt.	Auth Service Rep Only	a. Tilting gear and worm for contamination and for proper alignment and lubrication. ✕

OM-DHS

SYMPTOM	WHO	WHAT TO CHECK ✘ indicates items which must be performed by an authorized technician.
Spark is present but the pilot will not light.	Auth Service Rep Only	<ul style="list-style-type: none"> a. That the pilot valve is securely connected to terminals.✘ b. For 24 VAC at terminals PV and PV/MV. If 24V is not present, replace the ignition control module.✘ b. That gas pressure is at least 3.5" W.C.(8.7818 μb).✘ c. For gas at the pilot. If it is not flowing: <ul style="list-style-type: none"> (1) Check the pilot gas line for kinks and obstructions.✘ (2) Clean orifice, if necessary.✘ (3) Check magnetic operator for pilot valve on gas valve. Repair or replace as necessary.✘ d. That the pilot spark gap is located in the pilot gas stream. If not, adjust or replace the pilot burner.✘ e. For drafts. Shield the pilot burner, if necessary.✘
Pilot lights, but main burner will not come on and spark does not stay on.	Auth Service Rep Only	<ul style="list-style-type: none"> a. For 24 V between terminals PV and PV/MV. If 24V is not present, replace the ignition control module.✘ b. That gas pressure is at least 3.5" W.C.(8.7818 μb).✘ c. Electrical connections of the main valve to terminals, to assure that they are securely attached. Check magnetic operator for pilot valve on gas valve. Repair or replace as necessary.✘
Pilot lights, but main burner will not come on, the spark stays on.	Auth Service Rep Only	<ul style="list-style-type: none"> a. Check for bad burner ground. If necessary, repair with high temperature wire.✘ b. Pilot burner ceramic insulator for cracks.✘ c. That cable is not grounded out. If it is, correct the ground-out condition or replace cable.✘ d. For proper gas pressure.✘ e. Clean pilot assembly, or replace if necessary.✘ f. Tighten all mechanical and electrical connections.✘ g. If the pilot flame is weak, increase pilot orifice size.✘ h. Replace ignition control module.✘
Main burner comes on but will not stay on.	Auth Service Rep Only	<ul style="list-style-type: none"> a. Check burner ground for bad wire or connection. Replace if necessary with high temperature wire.✘ b. Check for low gas supply pressure. If necessary, replace ignition control module.✘

Parts List

To order parts, contact your Groen Certified Service Agency. Supply the model designation, part description, part number, quantity, and, where applicable, voltage and phase.

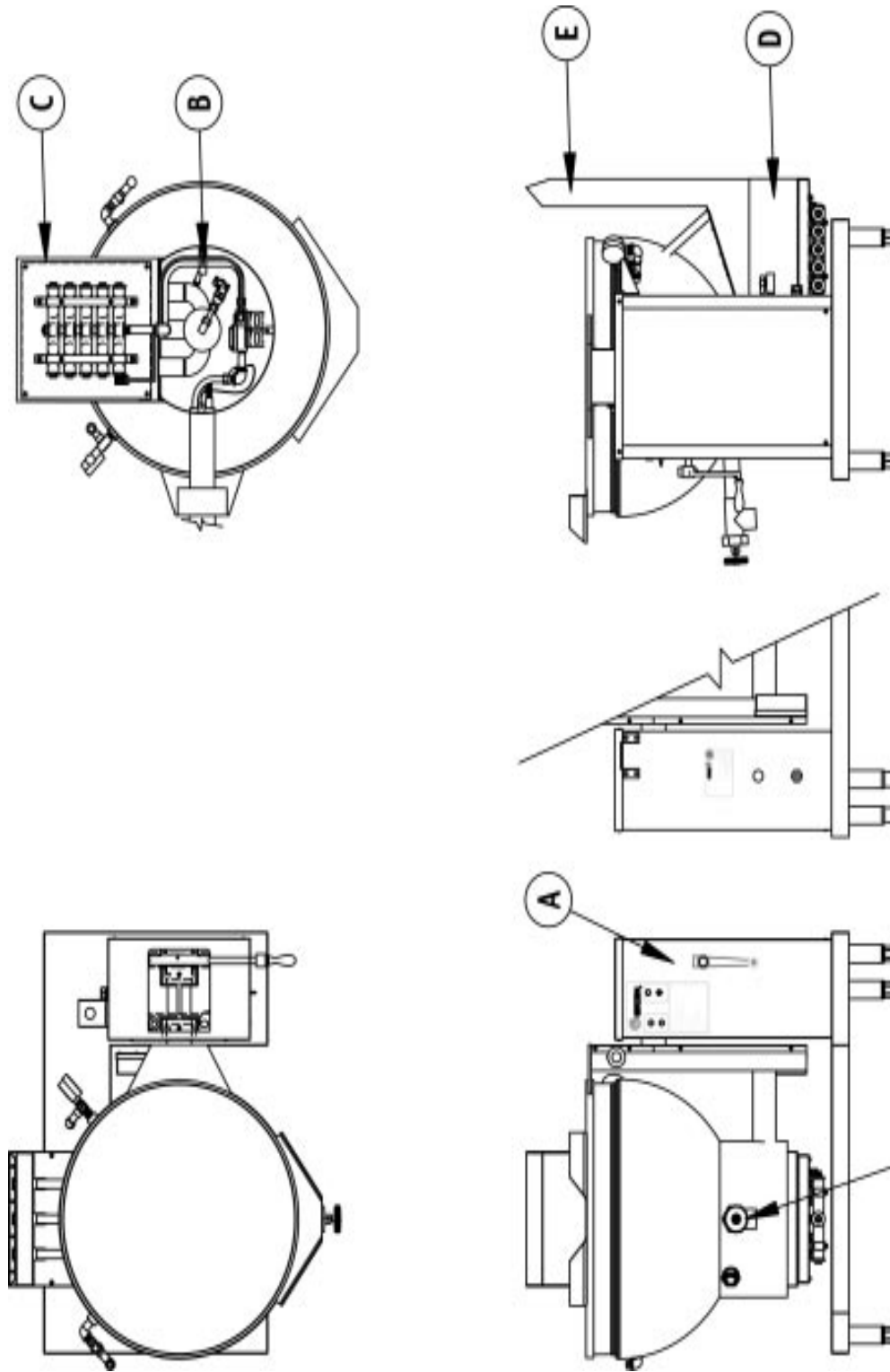

TANGENT DRAW OFF
TDO OPTIONAL

Parts List

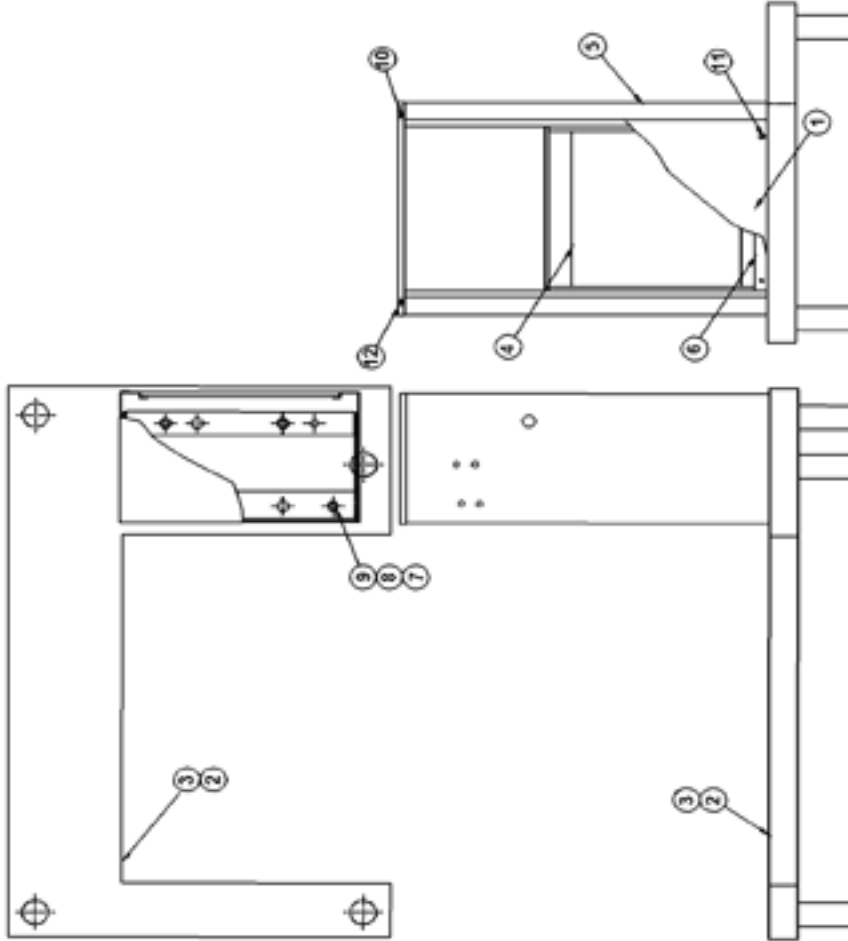

Stand and Housing Assembly

Key	Description	Part No.	Key	Description	Part No.	Key	Description	Part No.
A	Stand and Housing Assembly	139053	5	Housing Cladding, DHS -40	139179	10	Screw Truss #8-32 x 3/8	005764
1	Cabinet Side Panel	047882	6	Tray Liner	001475	11	Screw Truss #8-32 x 1-3/8 Lg.	081698
2	Stand Cladding	139056	7	Nut Hexagon 1/2-13 Heavy Duty	005603	12	Top Cover	138114
3	Base Assembly	137950	8	Screw Hex Head Cap 1/2-13 x1-1/2	008679	13	1/2" Plain Washer	005049
4	Pedestal Weldment Assembly	138101	9	1/2" Lock Washer	005657			

Parts List

To order parts, contact your Groen Certified Service Agency. Supply the model designation, part description, part number, quantity, and, where applicable, voltage and phase.

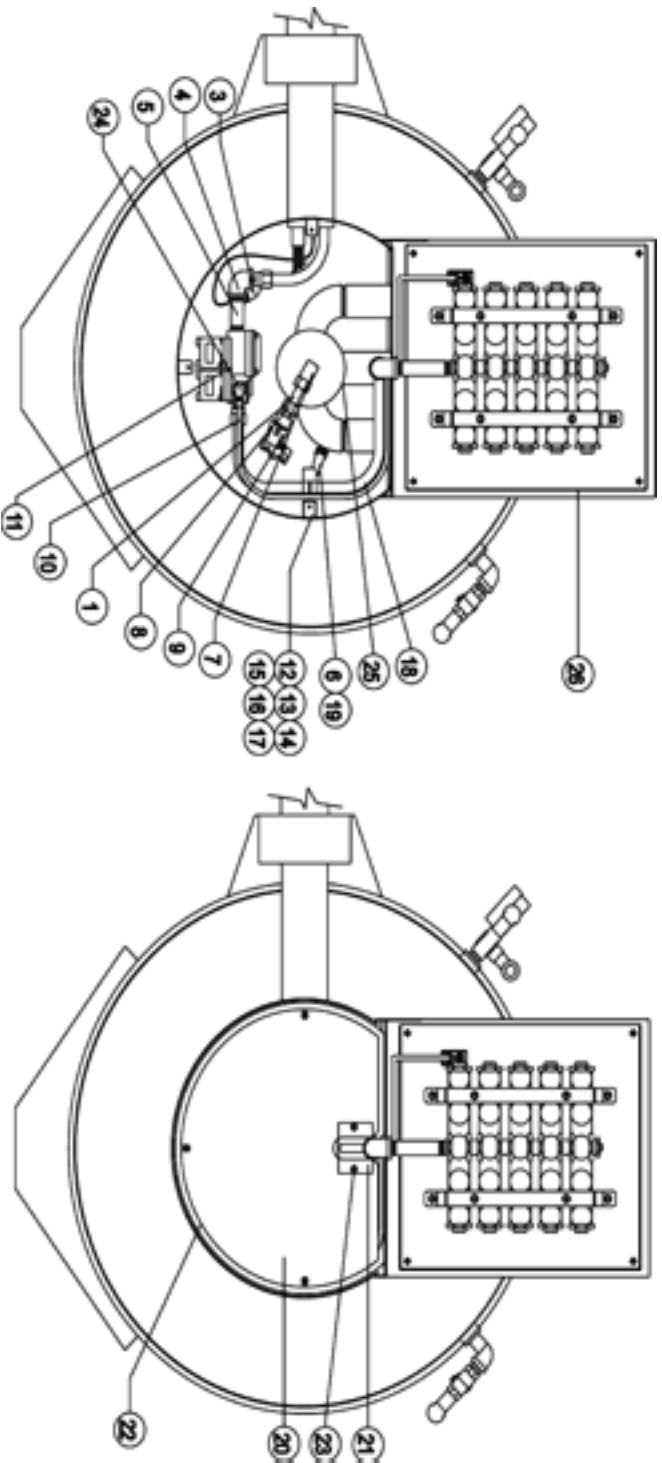

Gas Valve Piping and Bottom Components Assembly

Key	Description	Part No.	Key	Description	Part No.	Key	Description	Part No.
B	Gas Valve Piping&Bottom Comps.	139863	9	Pressure Switch 1/4"	096963	18	Tube, Aluminum 5/8" OD	063015
1	Tube, Copper, 1/2"	007334	10	Connector 1/2 NPT Male	049093	19	Boot Probe	101143
3	Thermostat, electric	009730	11	Gas Valve	123815	20	Cover, Bottom	090630
4	Elbow, 90 Deg 1/2 NPT	008747	12	Bracket Support	065382	21	Cap Bottom Cover Plate	049803
5	Nipple, 1/2 NPT x 2-1/2" Long	005552	13	Screw, Pan Head #8-32 x 3/8"	005764	22	Gasket, Bottom Plate	007937
6	Electrode, Water Level	002170	14	Nut, Hexagon Kep 1/4	012940	23	Screw, 10-32x3/8, Hex	069773
7	Elbow, 1/2" Tube x 3/8 " NPT	90737	15	Weld Stud	011028	24	Elbow, 1/8" NPT Male x 1/4" Tube	004584
8	Connector 1/4" NPT Female	097074	16	Bar, DHS-40 & 60	005440	25	Tube, Aluminum 1/4" OD x 32"	006796
			17	Clamp, Rigid Conduit, 1/2: NFPC	068687	26	Burner and Flame Sensor Assy.	123737

Electrical Schematic

Parts List

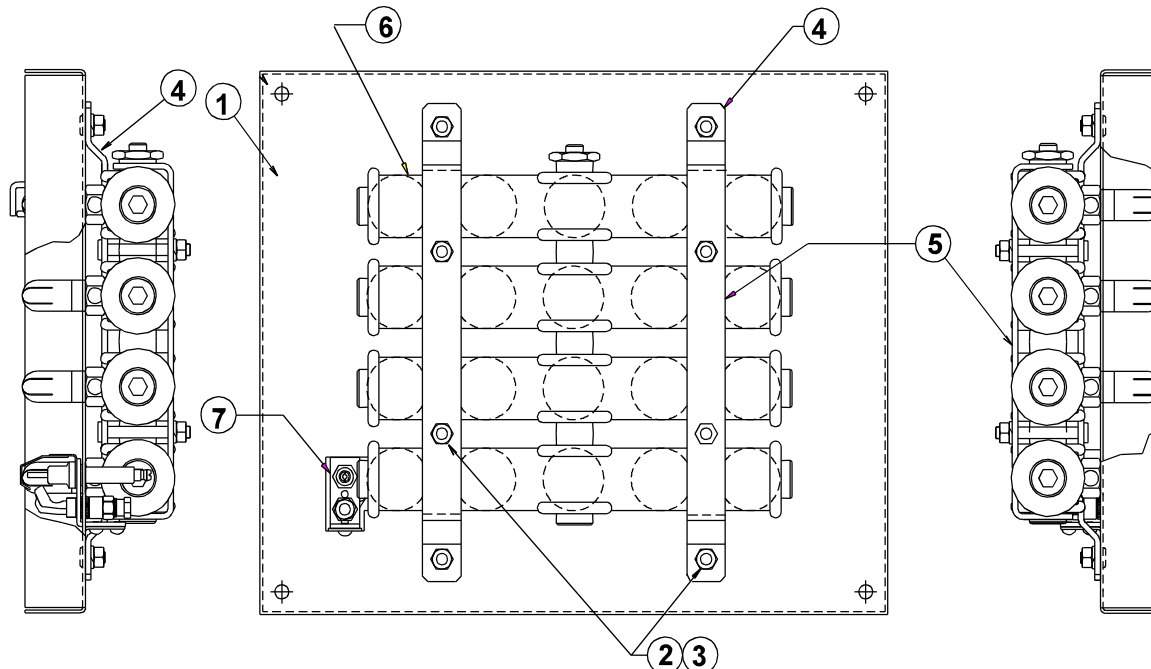

Burner and Flame Sensor Assembly

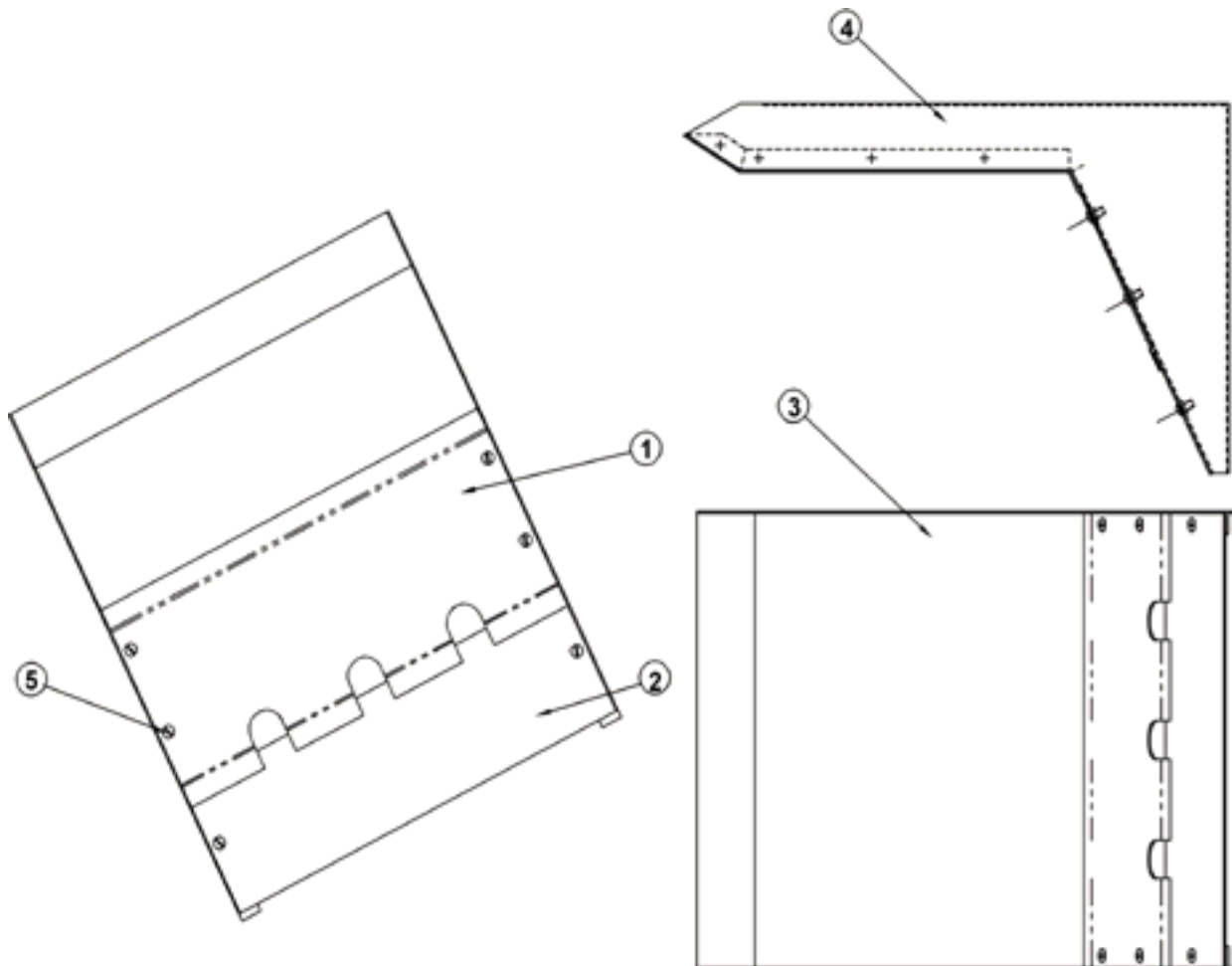

Flue Stack Assembly

OM-DHS

Parts List

To order parts, contact your Groen Certified Service Agency. Supply the model designation, part description, part number, quantity, and, where applicable, voltage and phase.

Key	Description	Part No.	Key	Description	Part No.
C	Burner and Flame Sensor Assy		E	Flue Stack Assembly	137871
	(Natural Gas)	123814	1	Flue, Top Section of Top Plate	
	(Propane)	139871	2	Flue, Bottom Section of Top Plate	
1	Baffle Plate	123498	3	Flue, Front Section	
2	Washer Lock	005655	4	Flue, Main Body	
3	Nut Hex	005601	5	Screw, Truss Head	
4	Burner Bracket Support	1017010			
5	Burner Bracket	117013			
6	Burner Assembly (Natural Gas)	090644			
	Burner Assembly (Propane)	139866			
7	Pilot Burner Assembly (Natural Gas)	123580			
	Pilot Burner Assembly (Propane)	128351			

Electrical Schematic

Parts List

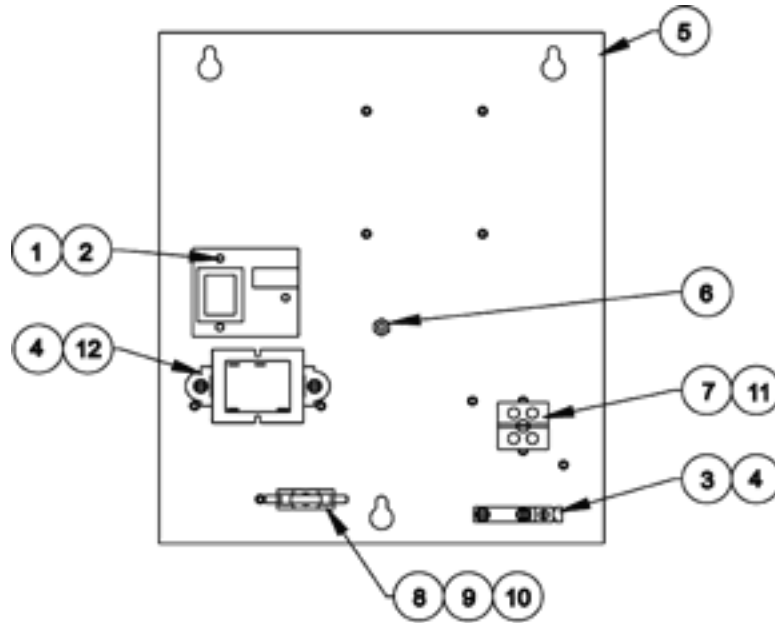

Electrical Panel

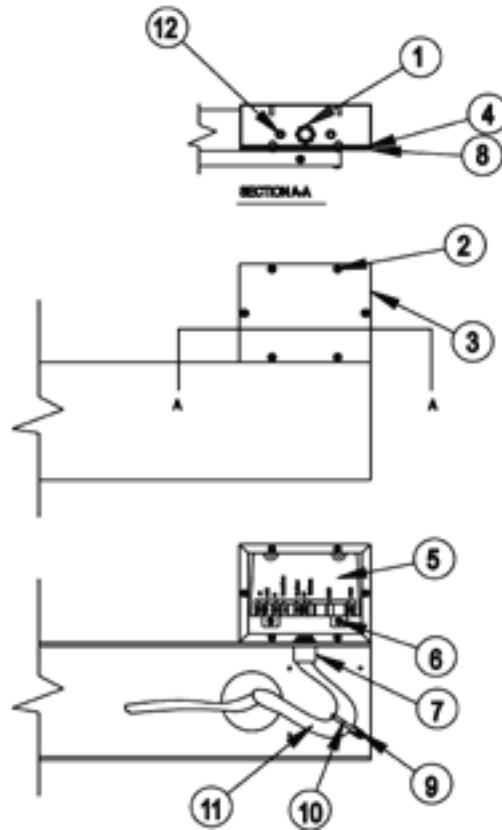

Arm and Module Box Assembly

OM-DHS

Parts List

To order parts, contact your Groen Certified Service Agency. Supply the model designation, part description, part number, quantity, and, where applicable, voltage and phase.

Key	Description	Part No.	Key	Description	Part No.
Electrical Mounting Assembly			Arm and Module Box Assembly		
1	Water Level Control Board	122192	1	Conduit Nut, 1/2"	005487
2	PC Board Mounting Post	099901	2	Screw #8-32 x 3/8"	005764
3	Lug Ground #14 -#6 AWG	129714	3	Box, Spark Ignition Module	123775
4	Screw #8-32 x 3/8" Hex Hd Cap	069789	4	Gasket, Ignition Module Box	104941
5	Electrical Panel Weldment	138123	5	Spark Ignition Module	085153
6	Nut #10-32 Hex Head w/shakeproof washer	071256	6	Hex Nut w/shakeproof washer	071289
7	Terminal Block	003887	7	Conduit, Plastic, male adapter 1/2"	123733
8	Fuse Holder Type 3AG	077854	8	Cover, Ignition Module Box	104948
9	Fuse 3.0 Amp Type 3Ag	077853	9	Hex Nut w/shakeproof washer	069784
10	Screw #6-32 x 3/8" Rd Hd Machine	009697	10	Tie Anchor - Screw Mounted	102231
11	Screw #8-32 x 1 1/4" Rd Hd Machine	005056	11	Cable Tie, 0.140 Wide Locking	086426
12	Transformer, 20 VA, 120V PRI, 24V Sec	137487	12	Screw #10=32 x 0.375 long	069773
	Transformer 208/240 PRI, 24V sec	137441			
13	Wiring Harness ASM.,	123582			
14	Wiring Harness ASM.,	123779			
15	Strap Cable Ty-Rap	011093			

Electrical Schematic

