



Floor Kettles model DEE/4

Description

Kettle shall be a Groen Model DEE/4 (Specify 20, 40, or 60 gallon) stainless steel steam jacketed unit, operating with an electric heated steam source contained within unit, per Bulletin 144241 and as follows:

Construction

Kettle interior shall be of type 316 stainless steel with solid one-piece welded construction. The console and all exposed surfaces shall be stainless steel.

The kettle body shall be mounted in a heavy-duty stainless steel combination kettle support tilt trunnion, which in turn is supported by the polished stainless steel enclosed base. The base shall be provided with stainless steel tubular legs with adjustable bullet feet. The enclosed support base shall contain a smooth operating, self-locking tilt mechanism, and shall be of sanitary, drip-proof construction with interior readily accessible for installation or maintenance.

The unit shall be furnished with a heavy reinforced bar rim with a welded-in butterfly shaped pouring lip for pouring control and durability.

All electrical components to be contained within the kettle and console. Designed for single point electrical connection.

Finish

Kettle interior shall be polished to a 180 emery grit finish. Exterior of kettle shall be finished to a bright high buff finish, ensuring maximum ease in cleaning and maintaining brilliant appearance.

ASME Code, UL Listed

Unit shall be ASME shop inspected, stamped and registered with the National Board for operation up to a maximum working pressure of 50 PSI. Unit shall be UL listed.

Sanitation

Unit shall be designed and constructed to meet NSF and known health department and sanitation codes, and be NSF listed.

Drawoff

A 2" tangent drawoff is optional. (Add "T" to model designation - DEE/4T). If drawoff is specified, outlet shall be equipped with removable 1/4" perforated stainless steel strainer.

Self-Contained Steam Source

Kettle shall have an electrically heated self-contained steam source to provide kettle temperatures of 150°F to approximately 295°F. Unit shall be factory charged with chemically pure water and rust inhibitors to ensure long life and minimum maintenance.

Controls

Controls shall include a thermostat, built-in contactor, safety tilt cut-off, safety valve, pressure gauge, water sight glass, heat indicator light and low water cutoff.

Model DEE/4T shown with optional 2" tangent draw-off



Performance Features

Unit shall be thermostatically controlled to automatically shut off when the desired temperature setting is reached and turn on when product temperature drops below setting. Smooth action manual tilt allows for easy pouring and transfer of kettle contents.

Installation

Specify 208, 240, or 480 Volt, single or three phase, 50 or 60 cycle electric service.

Options/Accessories

- 2" tangent draw-off valve with 1/4" perforated disk strainer
- Basket inserts (TRI-BC)
- Lift-off cover (#31)
- Hinged cover kit (#51)
- Pan carrier (40 and 60-gallon)
- Kettle brush kit
- Double and single pantry faucets
- Lip strainers
- 1/8" perforated disk strainer
- 1/4" perforated disk strainer
- Solid disk strainer
- Contour measuring strips
- Gallon etch marks

Origin of Manufacture

Kettle shall be designed and manufactured in the United States.

**Stainless Steel
2/3 Steam Jacketed
Kettle**

**Floor Mounted
Tilting
Self-Contained
Electric Heated
20, 40, or 60-
Gallon Capacity**

Short Form

Groen Model DEE/4 (Specify gallons), self-contained, tilting, electric heated, stainless steel steam jacketed kettle per Bulletin 144241. All stainless steel construction with reinforced bar rim, butterfly shaped pouring lip and smooth action mechanical tilt. Kettle body shall be mounted in heavy duty stainless steel combination kettle support tilt trunnion, which is supported by stainless steel enclosed base. NSF listed, ASME code constructed for 50 PSI and UL listed. Specify 208, 240, or 480 Volt, single or three phase 50 or 60 cycle. Made in U.S.A.



Applications

- Meat Dishes
- Vegetables
- Soups
- Sauces
- Pasta
- Rice
- Pie Fillings
- Gravies
- Poultry
- Seafood

CAP GALL.	TABLE OF DIMENSIONS											
	20		40		60		20		40		60	
	INCH	MM	INCH	MM	INCH	MM	INCH	MM	INCH	MM	INCH	MM
A	20	508	26	660	30	762						
B	35	889	47	1194	47	1194						
C	26	660	29	737	31	787						
D	30 3/4	781	34 1/2	876	36 3/8	924						
E	18 1/2	470	15 1/4	387	13 1/4	337						
F	39 3/8	1000	40 3/8	1026	44 1/8	1121						
G	16	406	12 1/4	31	10 3/8	264						
H	28	711	29 1/2	749	31 1/2	800						
J	28 1/4	718	29 1/2	749	29 1/2	749						
K	55	1397	57 1/2	1460	61 1/2	1562						
L	18 1/2	470	22	559	25	635						

KETTLE POWER ELECTRICAL TABLE			
MODEL	DEE/4-20	DEE/4-40	DEE/4-60
208V	10.8KW	21 KW	21 KW
1PH	52 AMP	101 AMP	101 AMP
3PH	30 AMP	59 AMP	59 AMP
240V	12 KW	24 KW	24 KW
1PH	53 AMP	105 AMP	105 AMP
3PH	31 AMP	61 AMP	61 AMP
480V	12 KW	24 KW	24 KW
1PH	25 AMP	50 AMP	50 AMP
3PH	15 AMP	29 AMP	29 AMP

OPTIONAL EXTRA COST FEATURES:

1. 2" TANGENT SANITARY DRAW-OFF
2. LIFTOFF COVER MODEL #31 FOR DEE/4-20 & DEE/4-40 KETTLES
3. HINGED COVER MODEL #51 FOR DEE/4-40 & DEE/4-60 KETTLES
4. OPTIONAL FAUCET WITH SWING SPOUT
5. DIMENSIONS IN BRACKETS [] ARE MM

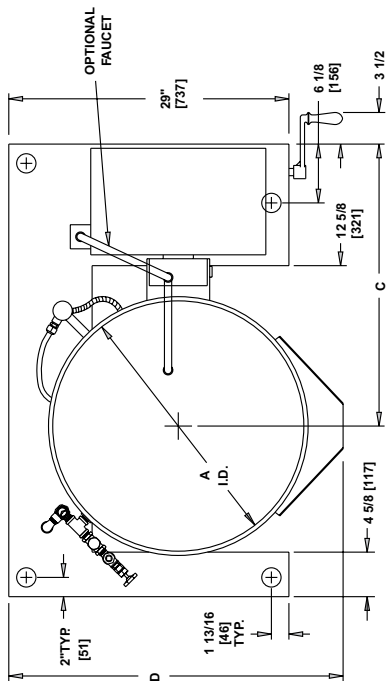

TOP VIEW

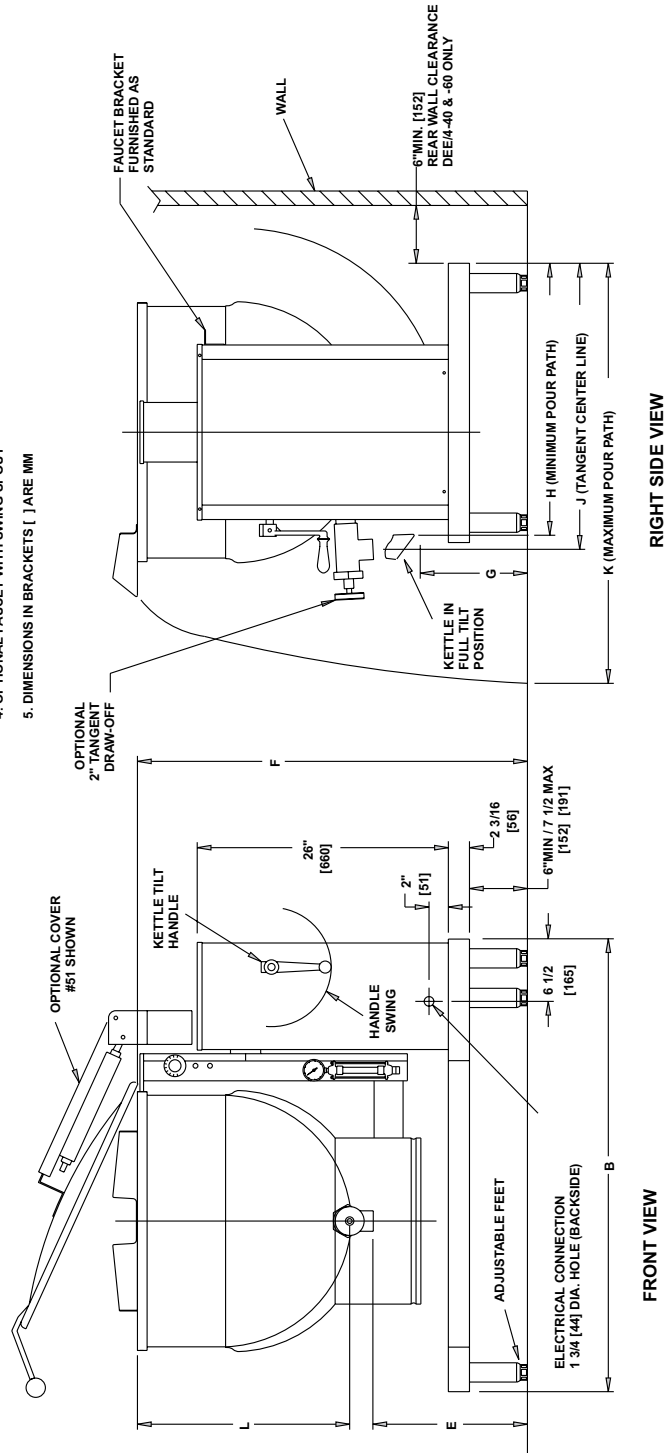

FRONT VIEW

RIGHT SIDE VIEW

