

**IMPORTANT INFORMATION ☆ KEEP FOR OPERATOR ☆ IMPORTANT INFORMATION**

# OPERATOR MANUAL

Part Number 121007 Rev. C

# OM-D

DOMESTIC

**MODELS: D, DT, DL, DLT,  
MW/D, MW/DT  
Steam Jacketed Kettles**

*Stainless Steel  
Direct steam heated  
Tilting*



Model DL

Model D

**THIS MANUAL MUST BE RETAINED FOR FUTURE REFERENCE.  
READ, UNDERSTAND AND FOLLOW THE INSTRUCTIONS AND  
WARNINGS CONTAINED IN THIS MANUAL.**

**WARNING**  
**DO NOT STORE OR USE GASOLINE OR OTHER FLAMMABLE  
VAPORS AND LIQUIDS IN THE VICINITY OF THIS OR ANY OTHER  
APPLIANCE.**



## IMPORTANT — READ FIRST — IMPORTANT

- CAUTION:** BE SURE ALL OPERATORS READ, UNDERSTAND AND FOLLOW THE OPERATING INSTRUCTIONS, CAUTIONS, AND SAFETY INSTRUCTIONS CONTAINED IN THIS MANUAL.
- WARNING:** THIS UNIT IS INTENDED FOR USE IN THE COMMERCIAL HEATING, COOKING AND HOLDING OF WATER AND FOOD PRODUCTS, PER THE INSTRUCTIONS CONTAINED IN THIS MANUAL. ANY OTHER USE COULD RESULT IN SERIOUS PERSONAL INJURY OR DAMAGE TO THE EQUIPMENT AND WILL VOID WARRANTY.
- CAUTION:** SHIPPING STRAPS ARE UNDER TENSION AND CAN SNAP BACK WHEN CUT.
- CAUTION:** UNIT WEIGHS 190 TO 270 LBS (85 TO 125 KG). FOR SAFE HANDLING, INSTALLER SHOULD GET HELP AS NEEDED, OR USE MATERIALS HANDLING EQUIPMENT (E.G., FORK LIFT, DOLLY OR PALLET JACK) TO REMOVE THE UNIT FROM THE SKID AND MOVE IT TO THE PLACE OF INSTALLATION.
- WARNING:** KETTLES MUST BE INSTALLED BY PERSONNEL QUALIFIED TO WORK WITH PLUMBING. IMPROPER INSTALLATION CAN RESULT IN INJURY TO PERSONNEL AND/OR DAMAGE TO EQUIPMENT.
- WARNING:** AVOID ANY EXPOSURE TO ESCAPING STEAM. STEAM CAN CAUSE SEVERE BURNS.
- WARNING:** TAKE EXTREME CARE TO KEEP HOT CONTENTS FROM SPILLING OR SPLASHING ON ANYONE. DO NOT STAND DIRECTLY IN FRONT OF KETTLE BODIES WHEN THEY ARE BEING TILTED.
- WARNING:** AVOID ALL DIRECT CONTACT WITH HOT EQUIPMENT SURFACES. DIRECT SKIN CONTACT COULD RESULT IN SEVERE BURNS.
- WARNING:** AVOID ALL DIRECT CONTACT WITH HOT FOOD OR WATER IN KETTLES. DIRECT CONTACT COULD RESULT IN SEVERE BURNS.
- CAUTION:** DO NOT OVER FILL THE KETTLE WHEN COOKING, HOLDING OR CLEANING. KEEP LIQUIDS A MINIMUM OF 2-3" (5-8 cm) BELOW THE KETTLE BODY RIM TO ALLOW CLEARANCE FOR STIRRING, BOILING AND SAFE PRODUCT TRANSFER.
- WARNING:** TAKE SPECIAL CARE TO AVOID CONTACT WITH HOT KETTLE BODY OR HOT PRODUCT WHEN ADDING INGREDIENTS, STIRRING OR TRANSFERRING PRODUCT TO ANOTHER CONTAINER.
- WARNING:** WHEN TILTING KETTLE FOR PRODUCT TRANSFER:
- 1) WEAR PROTECTIVE OVEN MITT AND PROTECTIVE APRON.
  - 2) USE CONTAINER DEEP ENOUGH TO CONTAIN AND MINIMIZE PRODUCT SPLASHING.
  - 3) PLACE CONTAINER ON STABLE, FLAT SURFACE, AS CLOSE TO KETTLE AS POSSIBLE.
  - 4) STAND TO LEFT OR RIGHT SIDE OF KETTLE (DEPENDING ON TILTING HANDLE PLACEMENT) WHILE POURING. DO NOT STAND DIRECTLY IN POUR PATH OF HOT CONTENTS.

**IMPORTANT — READ FIRST — IMPORTANT**

- 5) POUR SLOWLY, MAINTAIN CONTROL OF KETTLE BODY HANDLE AT ALL TIMES, AND RETURN KETTLE BODY TO UPRIGHT POSITION AFTER CONTAINER IS FILLED OR TRANSFER IS COMPLETE.
- 6) DO NOT OVERFILL CONTAINER. AVOID DIRECT SKIN CONTACT WITH HOT CONTAINER AND ITS CONTENTS.

- CAUTION:** KEEP FLOORS IN FRONT OF KETTLE WORK AREA CLEAN AND DRY. IF SPILLS OCCUR, CLEAN IMMEDIATELY, TO AVOID SLIPS OR FALLS.
- WARNING:** FAILURE TO CHECK SAFETY VALVE OPERATION PERIODICALLY COULD RESULT IN PERSONAL INJURY AND/OR DAMAGE TO EQUIPMENT.
- WARNING:** WHEN TESTING, AVOID ANY EXPOSURE TO THE STEAM BLOWING OUT OF THE SAFETY VALVE. DIRECT CONTACT COULD RESULT IN SEVERE BURNS.
- WARNING:** TO AVOID INJURY, READ AND FOLLOW ALL PRECAUTIONS STATED ON THE LABEL OF THE WATER TREATMENT COMPOUND.
- CAUTION:** MOST CLEANERS ARE HARMFUL TO THE SKIN, EYES, MUCOUS MEMBRANES AND CLOTHING. PRECAUTIONS SHOULD BE TAKEN. WEAR RUBBER GLOVES, GOGGLES OR FACE SHIELD AND PROTECTIVE CLOTHING. CAREFULLY READ THE WARNINGS AND FOLLOW THE DIRECTIONS ON THE LABEL OF THE CLEANER TO BE USED.
- CAUTION:** USE OF ANY REPLACEMENT PARTS OTHER THAN THOSE SUPPLIED BY GROEN OR ITS AUTHORIZED DISTRIBUTORS CAN CAUSE OPERATOR INJURY AND DAMAGE TO THE EQUIPMENT, AND WILL VOID ALL WARRANTIES.
- IMPORTANT:** SERVICE PERFORMED BY OTHER THAN FACTORY AUTHORIZED PERSONNEL WILL VOID WARRANTIES.

## Table of Contents

IMPORTANT OPERATOR WARNINGS .....	2
EQUIPMENT DESCRIPTION .....	5
INSPECTION AND UNPACKING .....	6
INSTALLATION .....	6
INITIAL START-UP .....	7
OPERATION .....	8
CLEANING .....	9
MAINTENANCE .....	11
SEQUENCE OF OPERATION .....	11
TROUBLESHOOTING .....	12
PARTS LISTS .....	13
DIAGRAMS & SCHEMATICS .....	21
REFERENCES .....	23
MAINTENANCE LOG .....	24
WARRANTY .....	26

## Equipment Description

### A. All Models

The Groen D Series are deep type, tilting kettles with direct steam-heated 2/3 jackets. The stainless steel kettles have welded, reinforced rims and butterfly shaped pouring lips. The liner and pouring lip of all kettles are 316 stainless steel. They are ASME shop-inspected, and are registered with the National Board. The kettles have a 180 emery grit interior finish and a bright semi-deluxe exterior finish.

Every unit requires a remote steam source. The steam supply is controlled by an inlet valve, and enters the jacket through one trunnion directly into the jacket. Steam pressure forces condensate out a dip tube through the other trunnion. Both steam and condensate lines are concealed within the support structures of the various models. The table at bottom right shows the standard kettle sizes for each model.

These kettles operate safely and efficiently at various steam pressures above five PSI, with upper pressure limits assured by the provided safety valve. Operation also requires a globe valve on the steam inlet and a strainer, steam trap, and check valve on the condensate outlet. These may be ordered from Groen as optional equipment.

D Series kettles are emptied by tilting, but optional tangent draw-offs are available. The standard draw-off is two inch outer diameter stainless steel, with compression disc valve and a removable stainless steel strainer that has 1/4 inch perforations. Strainers with 1/8 inch or no perforations are also available. The table on the bottom right shows the sizes of draw-offs which can be furnished with each model. When equipped with a tangent draw-off the designation "T" is added to the model designation.

The kettles in this series employ a worm and gear tilting mechanism, which is completely enclosed.

D Series kettles are mounted in three ways. Model D is suspended in a stainless steel yoke on a pedestal base. The outer circumference of the base is flanged down for proper sealing to the floor. Model DL is supported by a tubular, stainless steel tri-leg frame with adjustable floor flanges. The wall-mounted model MW/D has a supporting frame enclosed in a stainless steel, drip-proof housing. The frame must hang on an in-wall carrier which may be purchased as an option.

Other options include:

1. No. 31 lift-off cover (for kettles smaller than 60 gallons)
2. No. 51 cover with counter-balancing actuator (for 40 gallon and larger kettles)
3. Fill faucets with swing spout
4. Gallon Master water meter
5. TRI-BC basket cooking system
6. Kettle brush kit
7. Operating pressures up to 90 PSIG

Standard Capacities, Gallons					
Model	20	40	60	80	100
D	✓	✓	✓		
DT	✓	✓			
DL, DLT	✓	✓	✓	✓	
MW/D, MW/DT	✓	✓	✓	✓	✓

Optional Draw-Offs Available*			
Model	1½"	2"	3"
DT: 20 or 40 Gallon	✓	✓	
DLT: All Sizes	✓	✓	
MW/DT: All Sizes	✓	✓	✓

\*2" or 3" only provided on current production

## Inspection and Unpacking

The kettle will arrive completely assembled and wrapped in protective plastic, strapped and bolted on a heavy skid, enclosed in a three-wall cardboard crate. (80 gallon and larger kettles are in wooden crates.) Immediately on receipt remove the box and plastic wrap, and inspect the unit for damage. Report any damage or an incorrect shipment to the delivery agent.

Write down the model number, serial number and installation date, and keep this information for future reference. Space for these entries is provided at the top of the Service Log in the back of this manual.

**CAUTION**

**SHIPPING STRAPS ARE UNDER TENSION AND CAN SNAP BACK WHEN CUT.**

**CAUTION**

**AVOID NAILS AND SPLINTERS WHEN REMOVING KETTLES FROM WOODEN CRATES. WEAR SAFETY GLASSES.**

**CAUTION**

**UNIT WEIGHS 215 TO 295 LBS (98 TO 134 KG). FOR SAFE HANDLING, INSTALLER SHOULD GET HELP AS NEEDED, OR USE MATERIALS HANDLING EQUIPMENT (e.g., FORK LIFT, DOLLY OR PALLET JACK) TO REMOVE THE UNIT FROM THE SKID AND PLACE IT FOR INSTALLATION.**

When installation is to begin, cut the straps holding the unit on the skid. Lift the unit straight up off of the skid.

## Installation

**WARNING**

**THIS UNIT MUST BE INSTALLED BY PERSONNEL QUALIFIED TO WORK WITH PLUMBING. IMPROPER INSTALLATION CAN CAUSE INJURY TO PERSONNEL AND/OR DAMAGE TO EQUIPMENT.**

### A. All Models

1. Installation under a ventilation hood is recommended. Consult local codes.
2. Install and anchor the kettle on a level surface.
3. If the steam supply pressure is greater than the maximum working pressure stamped on the nameplate, you **must** install a pressure reducing valve in the steam supply line near the kettle.
4. Connect the steam supply line to the steam inlet fitting. Include a steam control valve and an appropriate safety valve. To obtain the full heating capability of the kettle, the steam supply line must be as large as the steam inlet fitting.
5. The safety valve is preset to relieve jacket pressure that exceeds its rated limit. Do not try to adjust the valve setting, and do not

allow the valve outlet or lever to be blocked.

6. Connect the kettle condensate return line to the boiler return line, or to a drain. A suitable steam trap, strainer, and check valve must be installed. (See piping diagram, Page 18).
7. Any mechanical change must be approved by the Groen Food Service Engineering Department.

### B. Floor Mounted Models

1. Install the unit on a level surface. Ensure that there is adequate clearance at the sides and rear, as required by the specification drawings. **Anchor** the pedestal or legs securely to the floor.
2. Apply a continuous bead of clear silicone sealant (No. 732 or equivalent) to the junction between the pedestal or leg flange and the surface, as shown in the illustration

below. Fill all cracks and crevices, and wipe excess away.

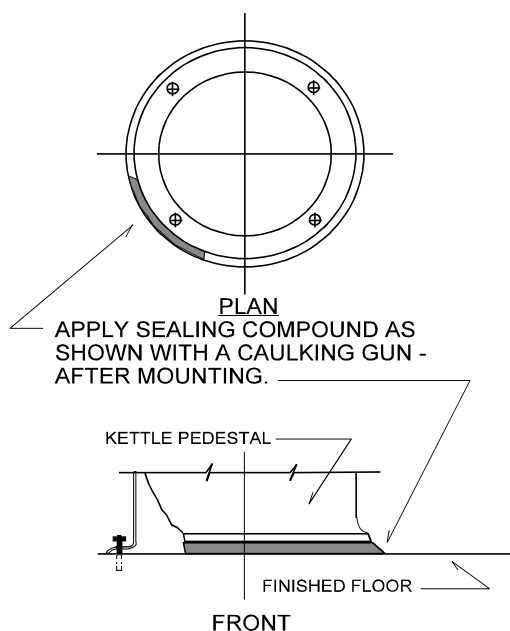

**For proper sanitation, continuous seal is required between pedestals or flanges and the mounting surface.**

### C. Cold Water Cooling Option

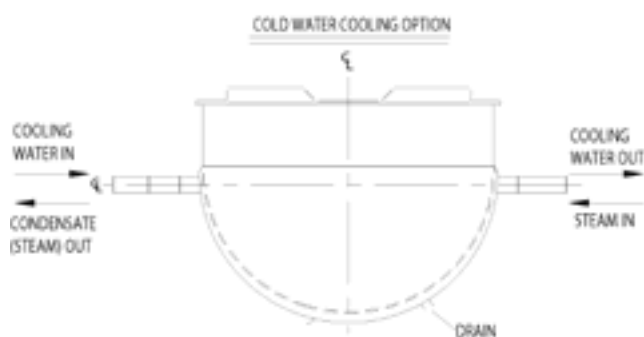

### D. Wall Mounted Models

1. Install a “chair carrier” in the wall to which the unit will be attached, following the instructions pertaining to anchoring and location. See diagram on page 19.
2. Stub in the steam supply line and condensate return line so that they will be aligned with the appropriate fittings when the unit is mounted.
3. Mount the unit on the protruding studs of the

chair carrier.

4. Apply a continuous bead of clear silicone sealant (No. 732 or equivalent) to the junction between the frame housing and the wall. Fill all cracks and crevices, and wipe away the excess.

## Initial Start-Up

### IMPORTANT

**BE SURE ALL OPERATORS READ, UNDERSTAND AND FOLLOW THE OPERATING INSTRUCTIONS, CAUTIONS, AND SAFETY INSTRUCTIONS CONTAINED IN THIS MANUAL.**

Now that the kettle has been installed, you should test it to ensure that it is operating correctly.

1. Remove all literature and packing materials from inside and outside of the unit. Clean out any material that might clog the tangent draw-off valve, if present.
2. Pour a small amount of water into the kettle.
3. Open the steam inlet valve.
4. When the water begins to boil, inspect all of the fittings to ensure that there are no leaks.
5. Check the safety valve by lifting its lever far enough to let steam escape. Then let it snap back into place to reseat the valve so that it will not leak.
6. Shut down the unit by closing the steam inlet valve.
7. Operate the tilting mechanism and draw-off valve to confirm that they function through the whole range of normal operation.

If the unit functions as described above, it is ready for use. If the unit does not function as intended, contact your local Groen Certified Service Agency.



### WARNING

**AVOID ANY EXPOSURE TO ESCAPING STEAM, WHICH CAN CAUSE SEVERE BURNS.**

## Operation

Before operating a **cold kettle**, open the petcock at the bottom of the jacket to drain any water left by condensing steam. Close the petcock before you open the steam inlet valve. Draining this water decreases the “hammering” you hear when steam enters a cold jacket.

To heat the kettle, open the steam inlet valve. Adjusting the inlet valve allows the operator to control the heating rate. Opening the valve more allows steam to flow into the jacket faster, and thereby heats the product faster.

The kettle operates efficiently with steam pressures from five PSI to the maximum working pressure for which the kettle was designed. The maximum allowable pressure is stamped on the kettle nameplate. It is 25 PSI for standard units.



**WARNING**

**AVOID EXPOSURE TO ESCAPING STEAM, WHICH CAN CAUSE SEVERE BURNS.**

Once a day, while there is still steam pressure in the jacket, bleed off any entrapped air and double check the operation of the safety valve. Pull out on its chain, or lift the lever far enough to let steam escape. Then let it snap back into place to reset the valve so that it will not leak.

### Tilting the Kettle

To transfer product or empty the kettle: turn the handwheel counterclockwise. The kettle will hold its position when you stop turning the wheel.

If the tilting mechanism seems to be locked, do **not** use force to free the kettle. Call for assistance from your Groen Certified Service Agency, or refer to the Troubleshooting section of this manual.



**WARNING**

**AVOID ALL DIRECT CONTACT WITH HOT FOOD OR WATER IN THE KETTLE. DIRECT CONTACT COULD RESULT IN SEVERE BURNS.**

**TAKE SPECIAL CARE TO AVOID CONTACT WITH HOT KETTLE BODY OR HOT PRODUCT, WHEN ADDING INGREDIENTS, STIRRING OR TRANSFERRING PRODUCT TO ANOTHER CONTAINER.**

**CAUTION**

**DO NOT OVERFILL THE KETTLE WHEN COOKING, HOLDING OR CLEANING. KEEP LIQUIDS AT LEAST 2-3" (5-8 cm) BELOW THE KETTLE BODY RIM TO ALLOW CLEARANCE FOR STIRRING, BOILING PRODUCT AND SAFE TRANSFER.**

**WARNING**

**WHEN TILTING KETTLE FOR PRODUCT FOR PRODUCT TRANSFER:**

- 1) WEAR PROTECTIVE OVEN MITT AND PROTECTIVE APRON.**
- 2) USE CONTAINER DEEP ENOUGH TO CONTAIN AND MINIMIZE PRODUCT SPLASHING.**
- 3) PLACE CONTAINER ON STABLE, FLAT SURFACE, AS CLOSE TO KETTLE AS POSSIBLE.**
- 4) STAND TO LEFT OR RIGHT SIDE OF KETTLE WHILE POURING – NOT DIRECTLY IN POUR PATH OF HOT CONTENTS.**
- 5) POUR SLOWLY, MAINTAIN CONTROL OF KETTLE AT ALL TIMES, AND RETURN KETTLE BODY TO UPRIGHT POSITION AFTER CONTAINER IS FILLED OR TRANSFER IS COMPLETE.**
- 6) DO NOT OVERFILL CONTAINER. AVOID DIRECT SKIN CONTACT WITH HOT CONTAINER AND ITS CONTENTS.**

## Operation Instructions for Optional Cold Water Cooling

(Reference Typical Piping Arrangement Drawings)

### Sequence of Operation for Heating

1. Close Water Inlet Valve, Kettle Drain Valve, and Water Outlet Valve
2. Open Condensate Outlet Valve
3. Open Steam Inlet Valve

### Sequence of Operation for Cooling

1. Close Steam Inlet Valve and Condensate Outlet Valve
2. Open Water Outlet Valve
3. Open Water Inlet Valve

### Sequence of Operation for Heating after Cooling

1. Close Water Inlet Valve and Water Outlet Valve
2. Open Kettle Drain Valve until jacket is empty
3. Open Condensate Outlet Valve
4. Open Steam Inlet Valve

## Cleaning

### 1. Suggested Tools

- a. Use a good cleaner
- b. Kettle brushes (long-and short-handled) in good condition.
- c. Brush suitable for cleaning the tangent draw-off port (if kettle has optional tangent).
- d. Use a good sanitizer
- e. Film remover



### CAUTION

**MOST CLEANERS ARE HARMFUL TO THE SKIN, EYES, MUCOUS MEMBRANES, AND CLOTHING. PRECAUTIONS SHOULD BE TAKEN. WEAR RUBBER GLOVES, GOGGLES OR FACE SHIELD, AND PROTECTIVE CLOTHING. READ THE WARNINGS AND FOLLOW THE DIRECTIONS ON THE LABEL OF THE CLEANER CAREFULLY.**

### 2. Procedure

- a. Clean food-contact surfaces as soon as possible after use. If the unit is in continuous use, thoroughly clean and sanitize the interior and exterior at least once every 12 hours.
- b. Scrape and flush out food residues. Be careful not to scratch the kettle with metal implements.
- c. Prepare a hot solution of the detergent/cleaning compound as instructed by the supplier.
- d. Clean the unit thoroughly, inside and outside.
- e. Rinse the kettle thoroughly with hot water, then drain completely.
- f. As part of the daily cleaning program, clean soiled external and internal surfaces.
- g. To remove stuck materials, use a brush, sponge, cloth, plastic or rubber scraper, or plastic wool with the cleaning solution. To reduce effort required in washing, let the detergent solution sit in the kettle and soak into the residue. **Do not use abrasive materials or metal tools that might scratch the surface.** Scratches make the surface harder to clean and provide places for bacteria to grow. **Do not use steel wool**, which may leave particles in the surface and cause eventual corrosion and pitting.



**Use only a sponge, cloth or plastic brush to clean the kettle.**



**Use only a sponge, cloth or plastic brush to clean the kettle.**

- h. The outside of the unit maybe polished with a stainless steel cleaner such as “Zepper” from Zep Manufacturing Co.
- i. When equipment needs to be sanitized, use a solution equivalent to one that supplies 200 parts per million available chlorine. Obtain advice on sanitizing agents from your supplier of sanitizing products. Following the supplier’s instructions, apply the agent after the unit has been cleaned and drained. Drain and thoroughly rinse off the sanitizer.

**CAUTION**

**NEVER LEAVE A CHLORINE SANITIZER IN CONTACT WITH STAINLESS STEEL SURFACES LONGER THAN 30 MINUTES. LONGER CONTACT CAN CAUSE STAINING AND CORROSION.**

- j. It is recommended that each piece of equipment be sanitized just before use.
- k. If there is difficulty removing mineral deposits or a film left by hard water or food residues, clean the kettle thoroughly and use a deliming agent, like Groen Delimer/Descaler (Part Number 114800) or Lime-Away® from Ecolab, in accordance with the manufacturer’s directions. Rinse and drain the unit thoroughly before further use.
- i. If cleaning problems persist, contact your cleaning product representative for assistance. The supplier has a trained technical staff with laboratory facilities to serve you.
- m. If your unit is equipped with a tangent draw-off valve, disassemble it and clean the draw-off port and each valve part with a brush.

**NOTICE: DO NOT MIX THE PARTS OF DIFFERENT DRAW-OFF ASSEMBLIES WHEN CLEANING. THE PARTS ARE NOT INTERCHANGEABLE.**

## Maintenance

**NOTICE:** Contact Groen or an authorized Groen representative when repairs are required.

### Periodic Maintenance

A Maintenance & Service Log is provided at the back of this manual with the warranty information. Each time maintenance is performed on your Groen kettle, enter the date on which the work was done, what was done, and who did it. File the log with the warranty.

Periodic inspection will minimize equipment down time and increase the efficiency of operation. The following points should be checked:.

1. Once a day, with pressure in the jacket, check the operation of the safety valve. Lift the lever of the safety valve until steam is released. Then release the lever and let the valve snap shut. If the lever does not activate, or there is no evidence of discharge, or the valve leaks, immediately discontinue use of the kettle and contact a qualified Groen service representative.



### WARNING

**WHEN TESTING, AVOID ANY EXPOSURE TO THE STEAM BLOWING OUT OF THE SAFETY VALVE. DIRECT CONTACT COULD RESULT IN SEVERE BURNS.**

2. At least once every 90 days, inspect fittings and valves for signs of damage or wear. Regularly examine trunnion packings and valve seats for wear, and replace them when necessary.

### CAUTION

**USE OF ANY REPLACEMENT PARTS OTHER THAN THOSE SUPPLIED BY GROEN OR AN AUTHORIZED SUPPLIER WILL VOID ALL WARRANTIES AND COULD INJURE THE OPERATOR OR DAMAGE THE EQUIPMENT.**

**NOTE:** Service performed by other than factory-authorized personnel will void all warranties.

3. Lubricate trunnions and gears with a good grade of high temperature grease. Grease trunnions at least once every 60 days, and grease gears when inspection shows that they are dry.
4. If the kettle cover has an actuator, lubricate it every 90 days.

**NOTE:** Use only Calcium Complex Nr. 2 Grease, which is available from Groen (Part No. 093703).

## Sequence of Operation

The following “action-reaction” outline is provided to help the user understand the function of the equipment.

When the steam inlet valve is opened, steam flows into the jacket at a pressure determined by the boiler system or by the pressure reducing valve that serves the kettle.

In the jacket, steam transfers heat to the kettle as it condenses into water. The steam trap allows condensate (water) to leave the jacket, while it holds steam in. When the steam is shut off, condensation produces a vacuum in the jacket, but the check valve in the condensate return line keeps water from flowing back into the jacket.

## Troubleshooting

Your Groen kettle will operate smoothly and efficiently if properly maintained. However, the following is a list of checks to make in the event of a problem. If the actions suggested do not solve the problem, call your qualified Groen Service Representative. For the phone number of the nearest agency, call your area Groen representative or the Groen Parts and Service Department. If an item on the list is followed by **✘**, the work should be done by a qualified service representative.

**WARNING**  
**USE OF ANY REPLACEMENT PARTS OTHER THAN THOSE SUPPLIED BY GROEN OR THEIR AUTHORIZED DISTRIBUTORS CAN CAUSE INJURY TO THE OPERATOR AND DAMAGE TO THE EQUIPMENT AND WILL VOID ALL WARRANTIES.**

SYMPTOM	WHO	WHAT TO CHECK
✘ indicates items which must be performed by an authorized technician.		
Kettle will not heat.	User	a. That the steam inlet valve is open. b. That the steam supply line is turned on. c. That the condensate return valve is open. d. That the boiler is operating properly. Steam should be supplied at a pressure greater than five PSI.
	Auth Service Rep Only	e. Steam supply line for blockage.✘ f. Condensate return line for blockage.✘ g. Steam trap operation.✘
Safety valve leaks a small amount of steam.	User	a. For contamination that prevents seating the valve. With substantial pressure in the jacket, lift the valve lever briefly all the way up, to blow the valve clean then let it snap back down to seat the valve.
	Auth Service Rep Only	b. Safety valve for defects. Defective valve MUST be replaced with an identical valve.✘
Safety valve leaks a large amount of steam.	Auth Service Rep Only	a. Steam supply pressure.✘ b. Safety valve for defects. Defective valve MUST be replaced with an identical valve.✘
Pipe fitting leaks	User	a. Is the fitting tight?
	Auth Service Rep Only	b. If the leak is at a trunnion, and tightening the packing gland does not stop the leak, replace the packing.✘
Kettle is hard to tilt	Auth Service Rep Only	a. Tilting gear and worm for the presence of any contamination and for proper alignment and lubrication.✘
Kettle makes a banging noise when steam is turned on.	User	Drain water from the jacket by opening the petcock at the bottom of the kettle before admitting steam into the jacket. Close the petcock before opening the steam valve.

**WARNING**  
**TO AVOID INJURY FROM SPLASHING OR SPILLING HOT CONTENTS, EMPTY THE KETTLE THROUGH THE DRAW-OFF OR BY BAILING BEFORE ANY WORK IS DONE ON THE TILTING MECHANISM.**

## Parts List

To order parts, contact your Groen Certified Service Agency. Supply the model designation, part description, part number and quantity desired.

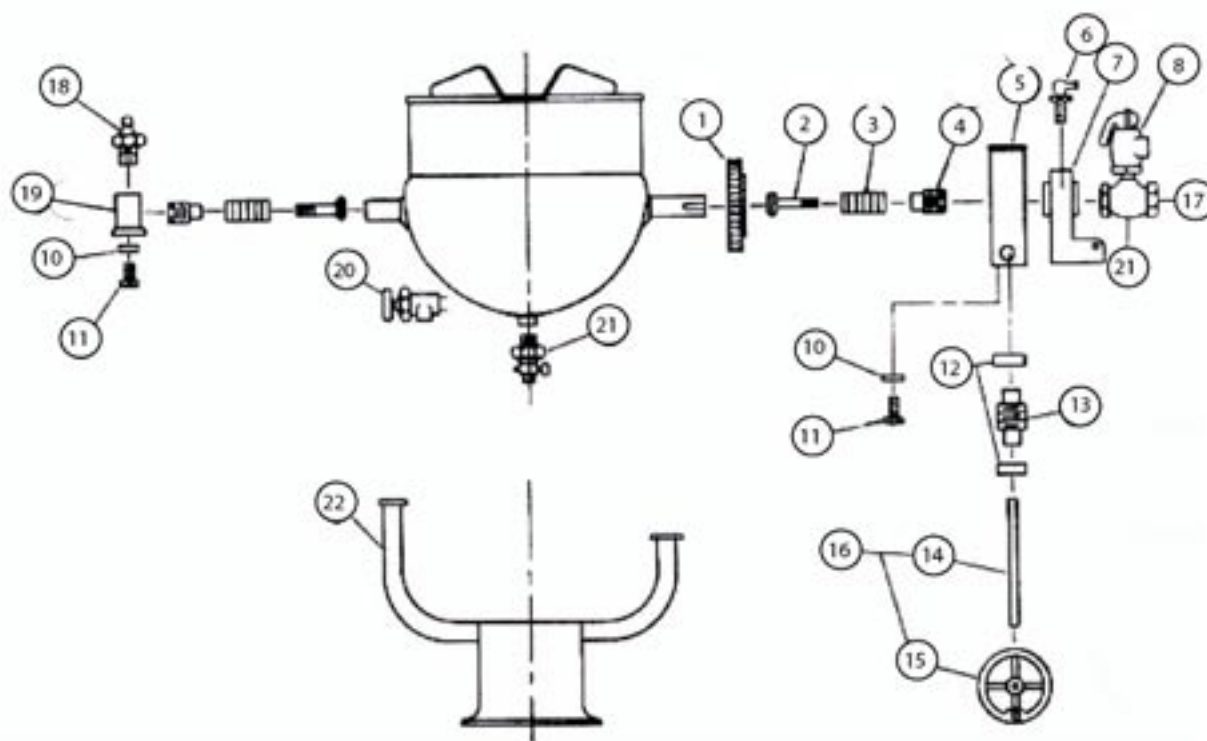

Models D, DT DL and DLT (after May 2002)

### Parts Lists

To order parts, contact your Groen Certified Service Agency. Supply the model designation, part description, part number and quantity desired.

Key	Description	Part No.	Key	Description	Part No.
1	Gear, Worm - D-20-40-60-80	012022	17	Collar	137246
2	Steam Gland - D-20-40-60-80	012120	18	Grease Fitting, 45 Deg	012099
3	Packing, 10 ring - D-20-40-60-80	114824	19	Casting Trunnion Race-20-40-60-80	012113
4	Nut, Packing - D-20-40-60-80	012122	20	Draw-Off Valve, 2" (Complete)	009046
5	Enclos. Tilt Mech. D-20-40-60-80	139043		Draw-Off Valve, 3" (Complete)	012262
6	Grease Fitting, 90 Deg.	012195		Handle for 2" TDO Valve	009029
7	Carrier Assy Gear D-20-40-60-80	137880		Handle for 3" TDO Valve	012209
8	Safety Valve <b>CAUTION: Pressure and flow rate of replacement valve must be the same as originally provided.</b>	-----		Stem for 2" Valve	009048
	3/4" Safety Valve (50 PSIG)	005587		Stem for 3" Valve	001908
	1/2" Safety Valve (50 PSIG)	097005			
9	Tee, Chrome Plated, 3/4 NPT	012075		Wing Nut for 2" Valves	009028
10	Lockwasher, 3/8	005618			
11	Screw Cap Hex 3/8-16x3/4	005611		Bonnet for 2"	009047
12	Bearing, Roller	002790		Bonnet for 3"	003925
13	Worm	12026		Hex Nut for 2"	009354
14	Shaft	003129		Hex Nut for 3"	003927
15	Handwheel with Handle	139152	21	Petcock, Jacket Drain	012070
16	Handwheel Shaft	003130	22	Stand Assembly (call GROEN for part numbers)	-----

### Parts Lists

To order parts, contact your Groen Certified Service Agency. Supply the model designation, part description, part number and quantity desired.

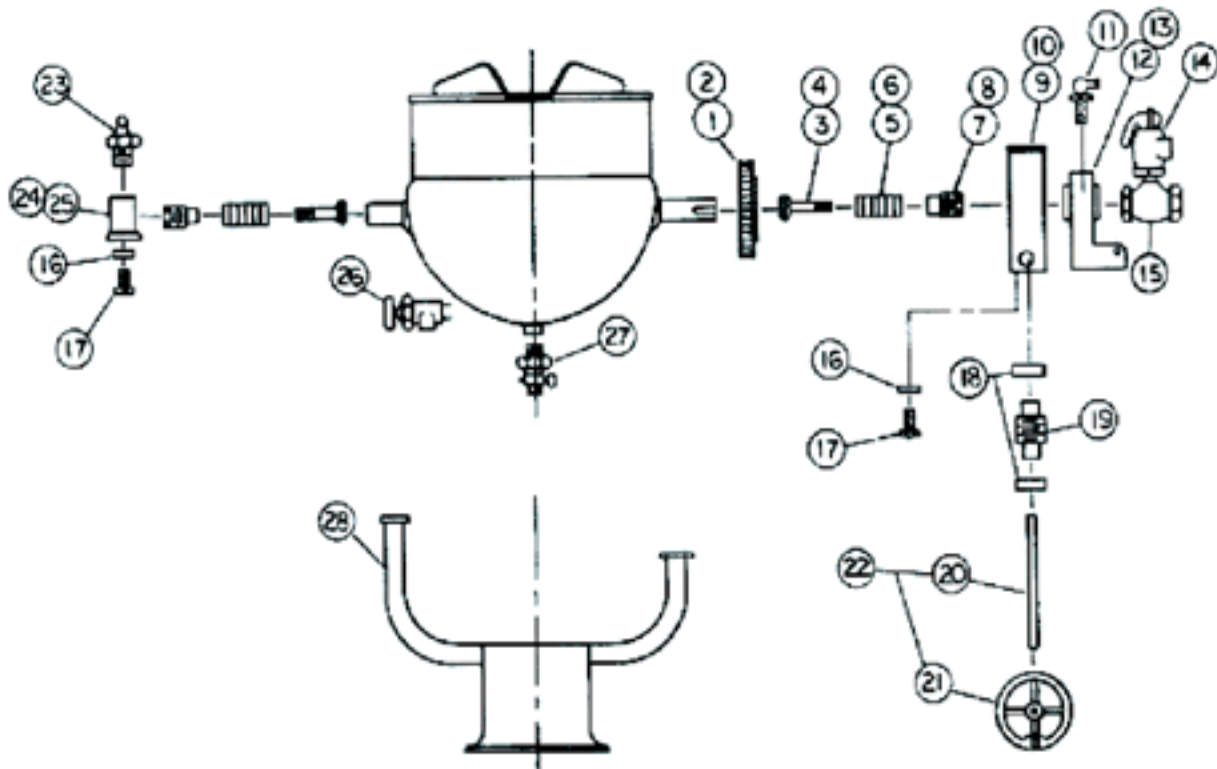

Models D, DT, DL and DLT (January 1974 - May 2002)

## Parts Lists

To order parts, contact your Groen Certified Service Agency. Supply the model designation, part description, part number and quantity desired.

Key	Description	Part No.	Key	Description	Part No.
1	Gear, Worm - D-10 -20 -30	012023	23	Grease Fitting, 45 Deg	012099
2	Gear, Worm - D-40 -60 -80	012022	24	Casting Trunnion Race- D-10 -20 -30	012109
3	Steam Gland - D-10 -20 -30	012227	25	Casting Trunnion Race - D-40 -60 -80	012113
4	Steam Gland - D-40 -60 -80	012120	26	Draw-Off Valve, Dairy 1½" (complete)	009000
5	Packing, 6 ring - D-10 -20 -30	012230		Draw-Off Valve, Dairy, 2" (Complete)	009046
6	Packing, 6 ring - D-40 -60 -80	114824		Draw-Off Valve, Dairy, 3" (Complete)	012262
7	Nut, Packing - D-10 -20 -30	012228		Handle for 1½" or 2" Dairy Valve	009029
8	Nut, Packing - D-40 -60 -80	012122		Handle for 3" Dairy Valve	012209
9	Enclos. Tilt Mech. D-10 -20 -30	014075		Stem for 1½" Valve	009027
10	Enclos. Tilt Mech. D-40 -60 -80	014076		Stem for 2" Valve	009048
11	Grease Fitting, 90 Deg.	012195		Stem for 3" Valve	001908
12	Carrier Assy, Gear D-10 -20 -30	014077		Wing Nut (with 001908)	
13	Carrier Assy Gear D-40 -60 -80	014079		Wing Nut for 1½" and 2" Valves	009028
14	Safety Valve	—		Draw-Off Valve, Plug, New Style, 1½"	009737
	<b>CAUTION: Pressure and flow rate of replacement valve must be the same as originally provided.</b>				
	¾" Safety Valve	005587		Draw-Off Valve, Plug, Old Style, 1½"	009734
	½" Safety Valve	097005		Draw-Off Valve, Plug, Old Style, 2"	009735
15	Tee, Chrome Plated, ¾ NPT	012075	27	Petcock, Jacket Drain	012070
16	Lockwasher, ⅜	005618		Bonnet for 1½"	009024
17	Screw Cap Hex Head ⅜-16 x ¾	005611		Bonnet for 2"	009047
18	Bearing, Roller	002790		Bonnet for 3"	003925
19	Worm	012026		Hex Nut for 1½"	008911
20	Shaft	003129		Hex Nut for 2"	009354
21	Handwheel with Handle	012061		Hex Nut for 3"	003927
22	Handwheel & Shaft (complete)	003130	28	Stand Assembly	—
				(Call GROEN for part numbers)	

### Parts List

To order parts, contact your Groen Certified Service Agency. Supply the model designation, part description, part number and quantity desired.

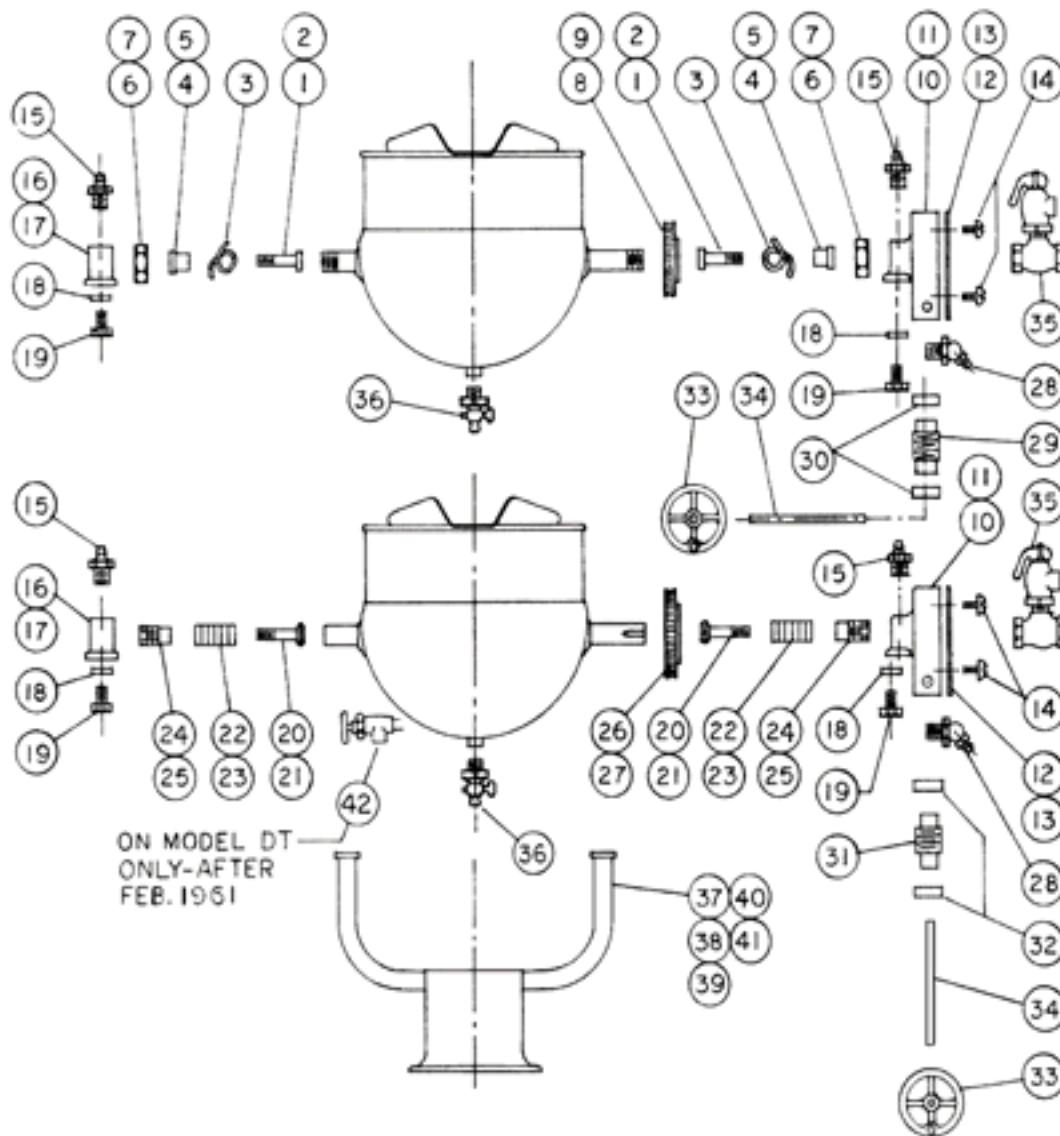

Models D, DT, DL, and DLT (before January 1974)

## Parts List

To order parts, contact your Groen Certified Service Agency. Supply the model designation, part description, part number and quantity desired.

Key	Description	Part No.	Key	Description	Part No.
1	Steam Gland 10-20-30 pre-Feb 1961	001235	30	Thrust Bearing	006052
2	Steam Gland 40-60-80 pre-Feb 1961	001211	31	Steel Worm Single RH	012026
3	Packing	001234	32	Thrust Bearing	012045
4	Packing Gland 10-20-30 pre-Feb 1961	001231	33	Handwheel	012061
5	Packing Gland 40-60-80 pre-Feb 1961	001236	34	Shaft	012004
6	Trunnion Nut 10-20-30 pre-Feb 1961	001232	35	Safety Valve	011004
7	Trunnion Nut 40-60-80 pre-Feb 1961	001237	36	Jacket Drain Petcock	012070
8	7½" D. Worm Gear 1⅝" Bore 1947-51	012064	37	Stand Assembly for D-10	011210
9	7½" D. Worm Gear 2" Bore 1947-51	012063	38	Stand Assembly for D-20	011220
10	Gear Housing 1⅝" hole - special order	012107	39	Stand Assembly for D-30	011230
11	Gear Housing 2" hole - special order	012111	40	Stand Assembly for D-40	011240
12	Gear Housing Cover (1¾" hole)	012050	41	Stand Assembly for D-60	011250
13	Gear Housing Cover (2⅛" hole)	012051		Draw-Off Valve 1½" (complete)	009000
14	No. 10-24x½" Round Head SS Screw	012065	42	Draw-Off Valve 2" (complete)	009046
15	Alemite Grease Fitting (Straight)	012100		Draw-Off Valve 3" (complete)	012262
16	Trunnion Race (1⅝" hole)	012109		Handle for 1½" or 2" TDO Valve	009029
17	Trunnion Race (2" hole)	012113		Stem for 1½" Valve	009027
18	⅜" Lockwasher	005618		Stem for 2" Valve	009048
19	⅜ - 16 N.C. x ¾" Long Hex Cap Screw	005611		Stem for 3" Valve	001908
20	Steam Gland (1⅝" Trunnion)	012227		Wing Nut for 1½" and 2" Valves	009028
21	Steam Gland (2" Trunnion)	012120		Bucket Trap ½"	004183
22	Packing (7-Ring)(1⅝" Trunnion)	012230		Bucket Trap ¾"	004050
23	Packing (7-Ring)(2" Trunnion)	002424		Low Water Cut-Off 115V	010412
24	1-5/16" O.D. Packing Nut	012228		Low Water Cut-Off 220V	010410
25	1⅝" O.D. Packing Nut	012122		Snap Bushing	000453
26	8½" Dia. Worm Gear (1⅝" Bore)	012023		Draw-Off Valve Plug 1½"	009737
27	8½" Dia. Worm Gear (2" Bore)	012022		Draw-Off Valve Plug 2"	009735
28	45° Alemite Grease Fitting	012099			
29	Steel Worm Single RH	012062			

### Parts List

To order parts, contact your Groen Certified Service Agency. Supply the model designation, part description, part number and quantity desired.

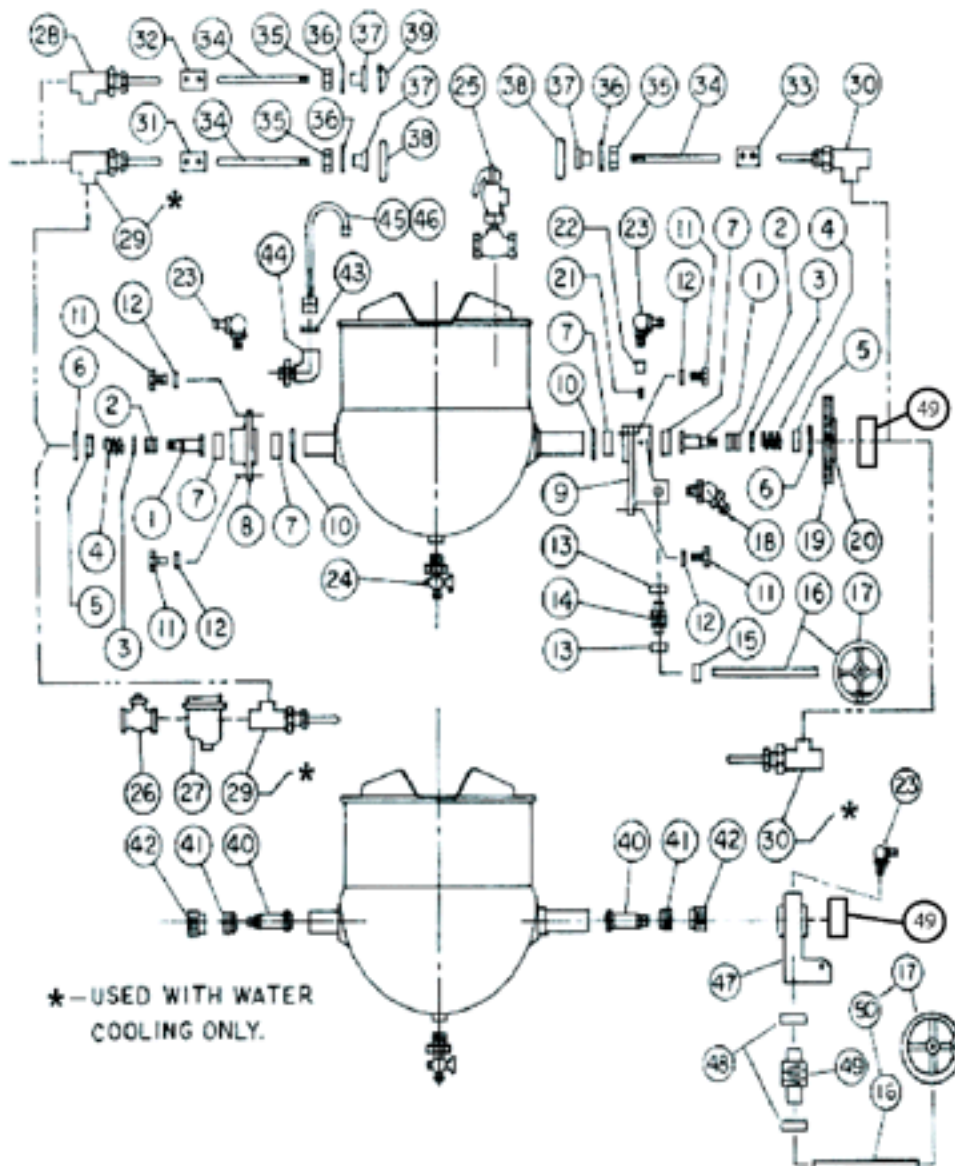

Models MW/D and MW/DT

## Parts List

To order parts, contact your Groen Certified Service Agency. Supply the model designation, part description, part number and quantity desired.

Key	Description	Part No.	Key	Description	Part No.
1	Steam Gland	009585	31	Coupler, 1/2" Valve Stem	012723
2	Ring Set, Packing (4-Ring)	009588	32	Coupler, 3/8" Valve Stem	012683
3	Washer, Packing	009567	33	Coupler, 3/4" Valve Stem	012724
4	Spring, Trunnion	012403	34	Extension, Valve Stem	012722
5	Retainer, Spring	009587	35	Hex Nut, 5/8-11 NC	007272
6	Ring, Tru-Arc	009586	36	Plain Washer, 5/8"	007273
7	Bearing, Oilite	009569	37	Sleeve, Valve Stem	002976
8	Race, Trunnion	009570	38	Handle, Black, 3 Dia	009029
9	Casting (not avail. - call Service Dept. for Conversion Kit)	—	39	Handwheel, Valve, with Insert	001148
10	"O" Ring, 2.5 ID x 2.875 OD	012304	40	Steam Gland for 2" Trunnion	012020
11	Screw, Hex Head Cap (prior to January 1974)	005699	41	Ring Set, Packing	002424
12	Washer, lock 3/8" (pre-January 1974)	005702	42	Nut, Packing for 2" Trunnion	012122
13	Bearing, Thrust (pre-January 1974)	012045	43	"O" Ring	010887
14	Worm, 3/4" Bore	012026	44	Body/Nut, Swivel Outlet	009860
15	Rubber Grommet	007245	45	Spout Gooseneck Swivel 20	009861
16	Handwheel/Shaft Assembly	012006	46	Spout Gooseneck Swivel 40-80.	009862
17	Handwheel Assembly	012061	47	Carrier Assembly Gear	014079
18	Fitting, Grease (pre-January 1974)	012099	48	Bearing, Roller	002790
19	Gear, 92 Teeth	012022		Draw-Off Valve 2" (complete)	009046
20	Screw, Hex Socket Set	012060		Draw-Off Valve 3" (complete)	012262
21	Close Nipple (prior to January 1974)	013206		Handle for 2" Valve	009029
22	Full Coupling (prior to January 1974)	004250		Handle for 3" Valve	012209
23	Fitting, 90 Degree, Grease	012195		Stem for 2" Valve	009048
24	Petcock, Jacket Drain	012070		Stem for 3" Valve	001908
25	Safety Valve-duplicate provided valve	—		Wing Nut (with 001908 )	
26	Valve, Swing Check 1/2 NPT	004187	49	Y-Strainer, 1/2"	004181
27	Trap, Bucket with Strainer 1/2"	004183		Collar	137246
28	Valve, Angle 3/8 IPS	012848			
29	Valve, Angle 1/2 IPS	012849			
30	Valve, Angle 3/4 IPS	012850			

## Bucket Steam Trap

STEAM INLET SIZE	STEAM OUTLET SIZE	USED ON
3/4" I.P.S.	3/4" I.P.S.	Models D, DT - 20, 40, 60 Models DL, DLT - 20, 40, 60, 80

KEY	DESCRIPTION	QNTY	Part No.
1	Gate Valve	1	004180
2	90° Reducing Street Elbow	1	010666
3	Close Nipple	3	008877
4	Female Union	1	004186
5	Bucket Steam Trap*	1	004183
6	Swing Check Valve	1	004187
7	Globe Valve	1	004222
8	Close Nipple	2	008238
9	Female Union	1	005516
10	90° Street Elbow	1	008347

\*NOTE: For Thermostatic Steam Trap use Part # 010250



Condensate Outlet Piping

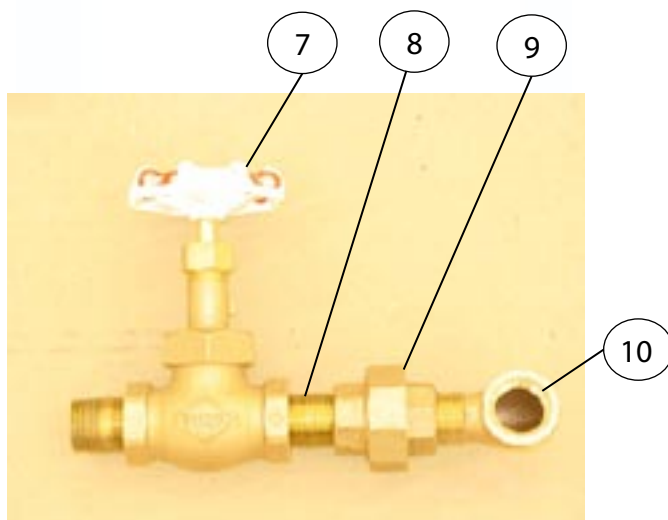

Steam Inlet Piping

## Installation Diagram Chair Carrier for Wall Mounted Kettles

MW/D AND MW/FT					
GAL CAP	20	40	60	80	
Liter	75	150	230	305	
A	25 1/2"	31 1/2"	35 1/2"	39 1/2"	
MM	647	800	901	1003	
B	23 1/2"	29 1/2"	33 1/2"	37 1/4"	
MM	597	749	851	946	

**NOTES:**

1. 6" -13 Lb. Channel
2. Spacer sleeves should be cut to proper length on installation to suit finished wall thickness
3. 7/8" diameter hole for anchor bolts on center line
4. Finished floor
5. Dimensions for kettles with 2" TDO only.
6. Due to continued product improvement, designs are subject to change without notice. Check with factory for current design.

