

Eclipse Braising Pan model BPM-30E/40E Marine Package

Description

Braising pan shall be a Groen Marine Package Eclipse™ Ergonomic Tilting Braising Pan Model BPM-30E or BPM-40E, electric- heated, manual tilting (specify 30 gallon) model BPM-30E or (specify 40 gallon) model BPM-40E with 10" deep pan on a rounded leg stand. Four flanged feet for attachment to deck.

Construction

The pan body shall be of type 304 stainless steel, solid one-piece welded heavy-duty construction, with 10" pan depth. All exposed surfaces shall be of stainless steel, except for the cover lift mechanism (aluminum) and the underside of the clad plate (mild steel), protected by a 304 stainless steel cover.

The cooking surface is a heavy 5/8" thick stainless steel clad plate fitted with clamped-on flat bar electric heating elements, ensuring efficient heat transfer over the entire cooking surface. The heavy plate prevents warping or distortion. (see operator's manual for proper warm up settings).

Controls and tilt mechanism are mounted in stainless steel housings, on the right pan body side. Braising pan shall come standard with mounting bracket for either right-side, left-side or rear faucet mounting.

Etch marks included.

Finish

Interior of braising pan shall be polished to a 100 emery grit finish. Exterior of braising pan shall be built to a #3 finish, ensuring maximum ease in cleaning and maintaining appearance.

Sanitation and NSF Listing

Braising pan shall be designed and constructed to be NSF-listed meeting all known health department and sanitation codes. True rounded leg tubular stand design and 3" radius pan interiors make cleaning easier. All exposed fasteners are 304 stainless steel box-head.

UL Listing

Braising pan shall be UL- and cUL- listed.

Manual Tilt

The braising pan shall have a smooth-action, quick-tilting body with manual crank tilt mechanism, which provides precise control during pouring of pan contents for easy operation. Pan body shall tilt past vertical to assist in cleaning.

Vented Cover

A heavy-gauge, fully adjustable one-piece cover is standard with torsion bar type counterbalance designed to maintain selected cover position. A vent is provided in the cover top to regulate condensate buildup and a rear

Model BPM-30E shown



condensate drip shield is located under the cover to prevent condensate from dripping on floor when cover is opened.

Controls

Operating controls include console mounted ON power switch, ON power indicator light, HEAT indicator light and temperature control. Protective cover supplied over controls.

Performance/Features

Braising pan shall be equipped with controls that allow operation at 7-degree angle to facilitate griddling. Braising pan shall be thermostatically-controlled for automatic shut-off when desired temperature is reached and temperature falls below desired setting. Braising pan to have High Limit thermostat as safety feature.

Installation

One electrical connection required. All marine units are available in 208, 240, 440 or 480 Volt, three-phase, 60Hz electrical service.

Options/Accessories

- Steamer Pan inserts
- Single pantry water faucet
- Double pantry water faucet
- Steamer pan carrier (Model BPC)
- 2" tangent drawoff (option: must be ordered with unit)
- Pouring lip strainer
- Strainer for tangent drawoff valve
- Single or Double pantry faucet with spray hose assembly (48" or 60")

Origin of Manufacture

Braising pan shall be designed and manufactured in the United States.

**Narrow Width
Stainless Steel
Manual Tilting
Braising Pan
Marine Package**

**Rounded Leg
Electric-Heated
30- and 40-Gallon
Capacity**

Short Form

Braising Pan shall be Groen Marine Package Eclipse™ Ergonomic Tilting Braising Pan stainless steel, electric-heated, thermostatically controlled, Model BPM-30E or BPM-40E, on a rounded tubular leg stand. Heavy 5/8" thick stainless steel clad pan bottom with clamped-on flat bar-type electric heating elements. 30 gallon pan is 39" wide and 40 gallon pan is 48" wide both with a 10" deep pan. Smooth-action quick-tilting pan body with manual crank tilt mechanism, heavy-duty fully adjustable counterbalanced cover with condensate drip shield and cover vent. Single electric connection required; for service specify voltage (208, 240, 440 or 480 Volt), three-phase, 60Hz. UL- and NSF- listed. Made in USA.



Applications

Braising meat
Pan frying chicken
Asian stir-fry
Steaming vegetables
Frying short order items
Sauteing
Sauces/Roux
Roasting turkeys
Boiling
Simmering
Thawing
Reheating prepared foods

ELECTRICAL REQUIREMENTS		BPM-30E		BPM-40E		
REQD VOLTAGE	PHASE	AMPS	Kw	AMPS	PHASE	Kw
240	1	48	11.5	64	1	15.3
440	3	28	10.5	37	3	14.0
480	3	14	11.5	19	3	15.3

TABLE OF DIMENSIONS		BPM-30E		BPM-40E	
MODEL	DIMS.	INCH	MM	INCH	MM
A	26.25	667	357.5	908	
B	32.00	813	41.5	1054	
C	38.50	984	48.00	1226	
D	8.75	222	13.50	343	

NOTES:

1. DIMENSIONS IN BRACKETS [] ARE MM.
2. FLANGED FEET SUPPLIED FRONT & REAR
3. ELECTRICAL CONNECTION: 1.75" DIA. [44] HOLE
4. OTHER VOLTAGES AND PHASES ARE AVAILABLE.
5. FAUCET BRACKET MAY BE INSTALLED ON LEFT OR RIGHT SIDE.
6. FAUCET MAY BE INSTALLED ON FAUCET BRACKET OR ON REAR AS SHOWN.
7. PROTECTIVE COVER OVER CONTROLS

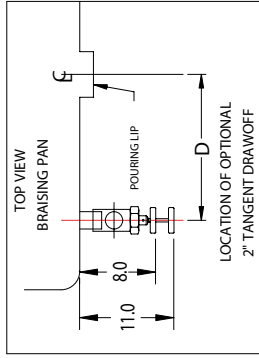
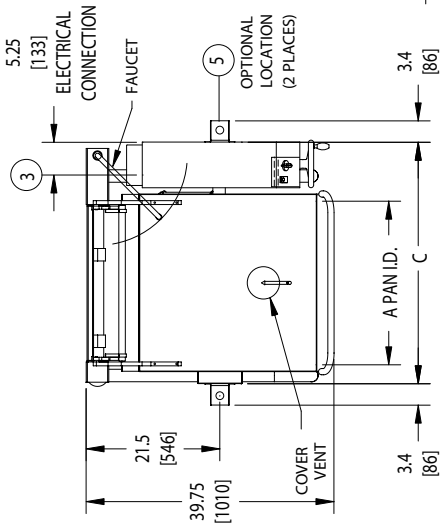

TOP VIEW

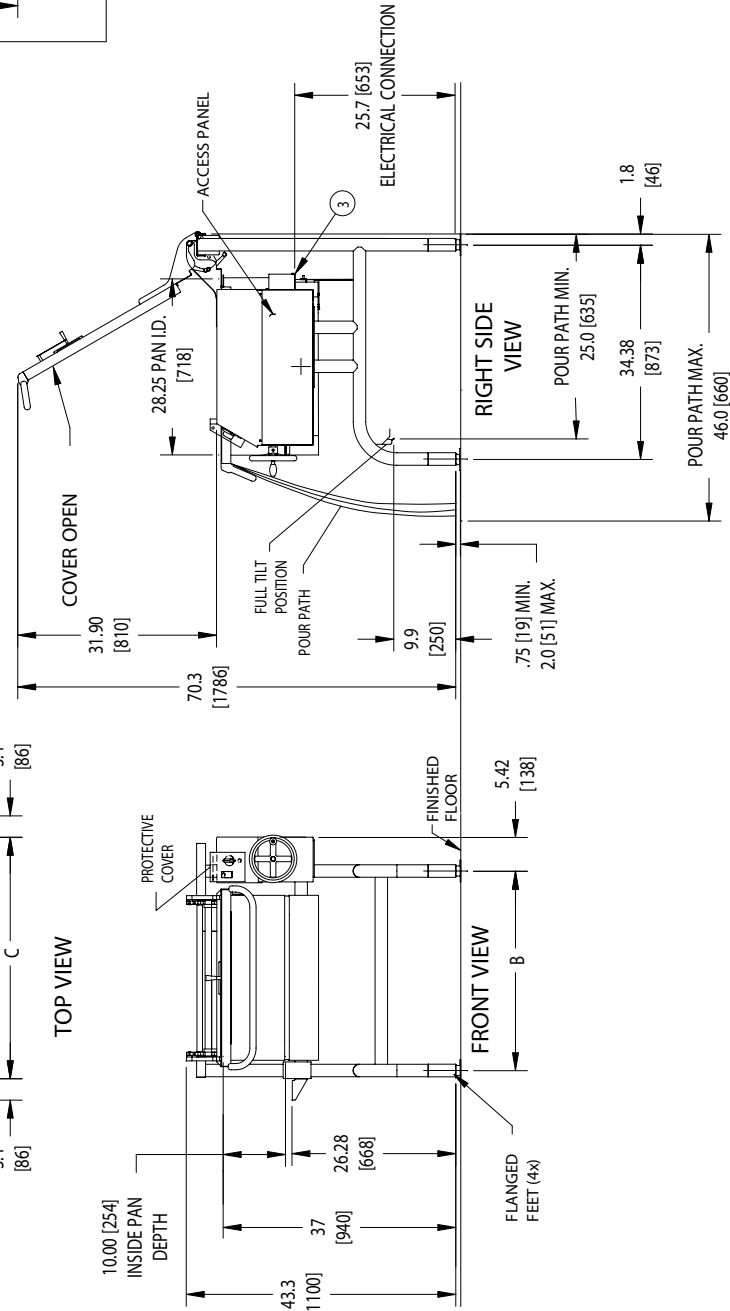

FRONT VIEW

