



HyPerSteam Pressureless Steamer models (2)HY-3E/EF/EC

Description

Steamer shall be Groen Model (2)HY-3E stainless steel stacked pressureless steamers, each with a self-contained atmospheric 8KW electric steam generator, per bulletin 140803 as follows:

Construction

Each steamer cavity and cabinet shall have all stainless steel construction with removable right side and left side panels providing access to internal components. Inter-unit water catch pan with rear drain shall separate units.

Steamer doors are all stainless steel with strong continuous hinge and are field reversible for left or right swing, doors shall be insulated and provided with a one piece, replaceable seal. Easy open handle and latch shall provide positive lock and seal when door is pushed or slammed shut.

Hidden magnetic door switch cuts power to blower and shuts down power to that generator when that door is opened. Pan support racks shall be polished stainless steel and removable for easy cleaning. A stainless steel condensate collection tray is positioned under each cavity door.

Finish

Cabinet exterior including doors shall be finished to a #3 uniform finish. Cavity interiors are polished stainless steel. Control panel face plates shall be smudge resistant polyester film, ensuring maximum ease in cleaning and maintaining an attractive appearance.

UL & CUL Listing

Steamers shall be UL and Canadian UL listed.

Sanitation

Unit shall be designed and manufactured to meet NSF codes and be NSF listed. Unit shall allow operator to delime each steam generator through delimiting ports on top, without tools or service call. Push button auto-clean feature is standard.

Controls

Steamer controls for each unit shall include an ON/OFF power button; 60 minute mechanical timer, with continuous steam setting; and READY light which indicates when cavity is ready for steaming. Auto-CLEAN button initiates delimiting cycle.

Performance Features

Each steamer shall have a powerful side-mounted blower, which increases steam velocity and provides efficient steam distribution throughout cavity and between loaded pans. Steam generator delivers 2.6 KW power input per 2 1/2" deep steam pan.

Heat up time to READY shall be 10 minutes or less under normal conditions. Cavity is kept warm and ready for instant steam between loads. No cavity warm up required, after READY light comes on.

delime indicator light warns operator of need to delime steam generator. Unit will shut off if water level is low. When power is turned "off", unit automatically drains that steam generator, to reduce sediment build-up.

Model (2)HY-3E shown



Atmospheric Steam Generators

Each unit shall have an electric heated rear mounted steam generator, to provide atmospheric steam to the chamber at a temperature of approximately 212°F. Each steam generator has an electric water sensor and 8KW electric heating element which is replaceable from the side.

Pan Capacity

Pan Size	Per Cavity	Total
12 x 20 x 1"	6	12
12 x 20 x 2 1/2"	3	6
12 x 20 x 4"	2	4

Installation

Unit requires two 208, 240 or 480 volt, single or three phase electrical service connections. Unit requires two 3/4" NH cold water supply lines and 1-1/2" free venting drain.

Water Supply Requirements

To minimize service problems, a PureSteam water treatment (softening) system is recommended when water quality is found to exceed limits stated below and in operator manual.

Recommended MINIMUM water quality standards are: Total dissolved solids (TDS) content should have a value of 30 to 40 parts per million; and the water pH should be 7.0 to 9.0

Options/Accessories

- Stainless steel support stand
- Pan racks for support stand
- 4" adjustable legs
- Optional second water connection for spray condensers

Origin of Manufacture

Steamer shall be designed and manufactured in the United States.

**6 Pan Total Capacity
Stainless Steel Stacked
Pressureless Steamers**

**Table Top or Stand
Mounted
Self-Contained
Electric Heated**

Short Form

Unit shall be Groen double stacked HyPerSteam pressureless steamers Model (2)HY-3E, each with self-contained, atmospheric electric heated steam generator, per Bulletin 140803. All stainless steel construction with a powerful blower to circulate steam within each cavity. Standard operating controls including: 60 minute mechanical timer, constant steam setting, ready light and CLEAN cycle button to initiate delimiting. Simple generator delimiting through delimiting ports on top. Doors are field reversible, with easy open latch and hidden magnetic door switch. Atmospheric steam generators require no pressure gauge or switches, have automatic water drain and 8KW power input. Units shall come up to steam in 10 minutes or less from a cold start, and provide warm cavity-instant steam capability. See other side for electric, water and drain connections required. Made in the U.S.A.



Applications

- Pasta
- Rice
- Vegetables (Fresh & Frozen)
- Seafood (Fresh & Frozen)
- Poultry
- Potatoes
- Eggs
- Meats
- Reheat Cook-Chill & Prepared Foods

SERVICE CONNECTIONS & NOTES:

- ① ONE DRAIN CONNECTION: 1-1/2" TUBE (DRAIN FREE VENTING).
- ② COLD WATER SUPPLY AT 30 TO 60 PSIG WITH A FLOW RATE OF 1.50 - 3.00 GPM PER CAVITY (3.00 - 6.00 GPM TOTAL) AND WITH A 3/4" NH CONNECTION.
- ③ TWO ELECTRICAL CONNECTIONS: 3/4" CONDUIT FITTING. [SEE ELECTRICAL REQUIREMENT TABLE]
- ④ MINIMUM SIDE AND REAR CLEARANCE.
- ⑤ DIMENSIONS IN BRACKETS [] ARE MM.

ELECTRICAL REQUIREMENTS - EACH UNIT			
VOLTAGE	PHASE	AMPS	MAX. KW
208	1	39	8
	3	23	8
240	1	33	8
	3	20	8
480	1	17	8
	3	10	8

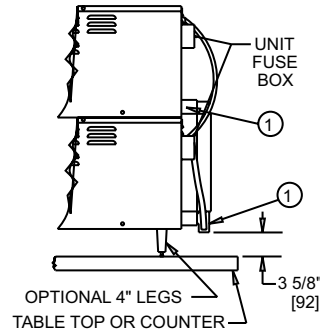
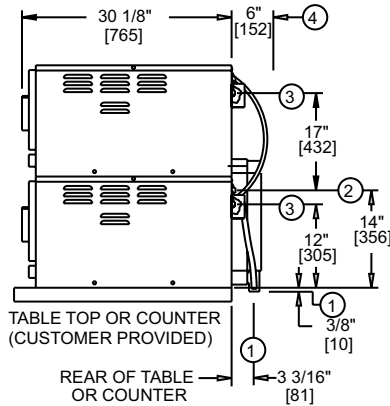
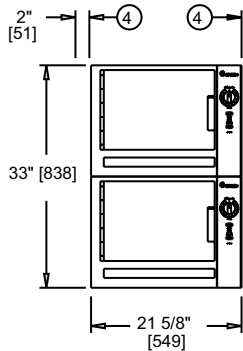
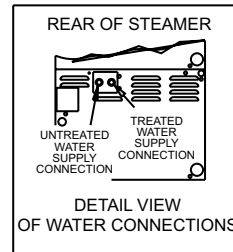
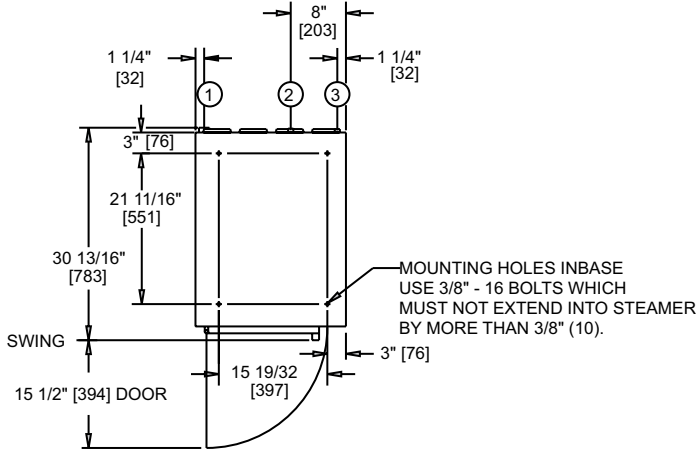

OPTIONAL SUPPORT STANDS (FRONT VIEWS)

