



Modular Equipment model (2)CTDC/3-20-SM

Description

Unit shall be a Groen Model (2)CTDC/3-20-SM, with two 20 quart stainless steel tilting steam jacketed kettles mounted on cabinet base, per bulletin 341c and as follows:

Construction

Kettles shall be Type 304 stainless steel with solid one-piece welded construction, with tubular stainless steel support arms. Rim shall be triple reinforced to resist abuse, with a welded "Butterfly" shaped lip, for easy pouring. Kettles shall have two operating handle lugs so that handle can be attached on right or left side.

36" wide cabinet base shall have stainless steel frame, top deck, double panel access doors, side and rear panels and 6" legs. Front legs shall be adjustable bullet feet while back legs shall have adjustable flanged feet. Cabinet design and trim shall match other HyPLUS™ modular equipment.

Finish

Cabinet base shall be finished to a #3 uniform finish. Kettle exteriors shall be polished to a bright high buff finish. Accent strip shall be matt finish polyester film ensuring maximum ease in cleaning and maintaining an attractive appearance.

ASME Code

Kettles shall be ASME Code constructed and National Board registered for operation up to 55 PSI.

Sanitation

Unit shall be designed and manufactured to meet NSF known health department and sanitation codes and be NSF listed.

Sinks/Faucet

Unit shall have one large flush mounted pouring sink positioned within pour path of each kettle. Sink shall be piped to common drain and provided with a removable anti-splash screen. Unit comes standard with hot and cold water faucet with swing spout.

Controls

Each kettle shall have a front mounted steam control valve. Hot and cold water faucet handles shall be front mounted and protected by deck overhang and full width door pulls.



Performance Features

Kettles shall operate dependably at any steam pressure between 5 and 55 PSI. Higher working pressures available as an option.

Installation

Unit requires 3/8" NPT hot and cold water supply lines. Requires single 1 1/2" NPT drain for kettles and sink. Unit requires 1/2" NPT steam connection that delivers a minimum of 54 lbs./hr. at 55 PSI maximum.

Options

- Lift-off covers for kettles
- Basket inserts for kettles
- Kettle brush kit

Origin of Manufacture

Kettle and cabinet mounted electric steam boiler shall be made in the United States.

**Stainless Steel
2/3 Steam Jacketed
Tilting Kettles**

**Cabinet Mounted
Direct Steam**

Short Form

Unit shall be a Groen HyPLUS™ style cabinet base with two 20 quart tilting steam jacketed kettles per bulletin 341c. Kettles have one piece welded construction of Type 304 stainless steel with reinforced bar rim and butterfly shaped pouring lip. Stainless steel support arms, and two lugs for right or left hand tilt standard. Cabinet base has stainless steel frame and exterior, removable double panel doors, single pouring sink positioned in front of kettles, hot and cold water fill faucet, and 6" adjustable legs. Hot and cold water, condensate drain and steam connection required, (See reverse side). Made in USA.



Applications

- Fresh and Frozen
- Vegetables
- Gravies
- Sauces
- Soup
- Puddings
- Pie Fillings
- Pasta
- Open Kitchen Display
- Cooking

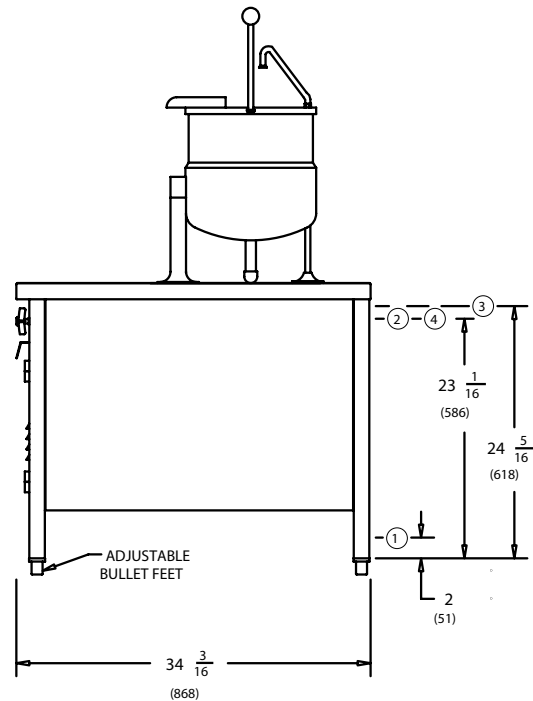
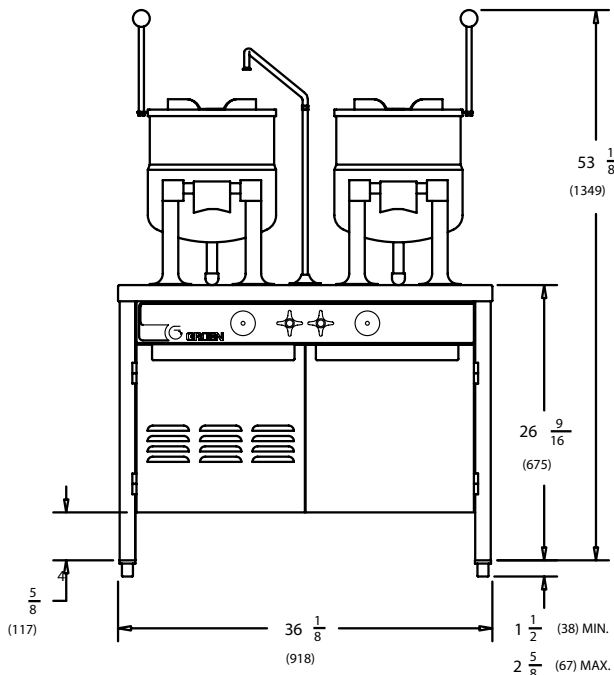
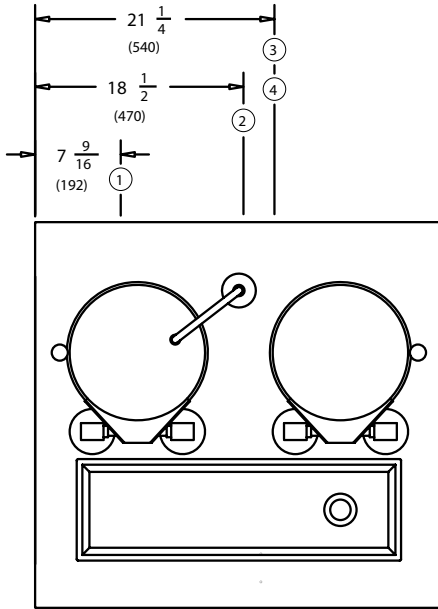

DIMENSIONS: INCHES (MILLIMETERS)

SERVICE CONNECTIONS:

- ① DRAIN CONNECTION: 1-1/4"(32) NPT (INCLUDES KETTLES & SINK)
- ② COLD WATER SUPPLY: 3/8"(9) NPT (FOR FAUCET)
- ③ HOT WATER SUPPLY: 3/8"(9) NPT (FOR FAUCET)
- ④ STEAM CONNECTION: 1/2"(13) NPT - 54 LBS/HR (MIN.) @ 55 PSI (MAX.)

