



# INDUSTRIAL LUBRICATION EQUIPMENT

Innovative Product Solutions for Mining  
and Industrial In-Plant Applications



LUBRICATION

PROVEN QUALITY. LEADING TECHNOLOGY.

# Graco Inc.



## More Than 75 Years in the Lubrication Business

Since 1926, Graco has been a leading manufacturer of equipment for the lubrication professional. Our oil and grease pumps; dispense valves and meters; hose reels; used-oil equipment and fluid management systems are the industry standard and the first choice for the most demanding applications.

Our Lubrication Equipment Division is at the heart of a corporation now with annual revenue in excess of \$500 million.

### *What makes our lubrication equipment so special?*

- Reliable performance day after day in the most demanding environments
- Our ability to meet job requirements with high-quality equipment
- Industry leading customer support and product availability

## LARGE DISTRIBUTION NETWORK

As partners in the lubrication business for over 75 years, our knowledgeable world-wide distribution network provides easy access to professionals who understand the unique needs of your business and who are able to recommend the equipment that best fits your application.

## STATE-OF-THE-ART FACILITIES

Graco's 590,000 sq ft of manufacturing, filled with state-of-the-art equipment and over 240,000 sq ft Distribution Center, provide quality products second-to-none and ensure you'll get the equipment you need when you need it.

## RESEARCH & DEVELOPMENT

Graco is dedicated to 'finding the future' in products and services. Graco invests \$15 – \$20 million in product research and development each year – giving you product with a competitive edge.

## ISO-9001 CERTIFICATION

Graco's excellence in manufacturing is enhanced by ISO-9001 Certification.

## CUSTOMER SERVICE

Leading the industry with total customer support, the Graco Lubrication Equipment Division offers you a dedicated Customer Support Team throughout the world.

## The Leader in Lubrication Equipment Technology

Dedicated to providing you with the most reliable and cost-effective equipment available, Graco offers a complete line of grease and oil pumps, hose reels, dispense valves and accessories.

Our packaged solutions deliver the highest quality results in all areas of manufacturing; including marine, automotive assembly, truck, construction, mining and machine tool markets. Installation expertise is available through an experienced and dedicated sales force.

### **FIRE-BALL®**

*The Graco Fire-Ball is a premier Graco pump and is an industry standard for industrial and vehicle lubrication.*



## Graco offers:

### **BULK OIL AND GREASE TRANSFER, UNLOADING AND EVACUATION**

- Bulk grease totes, drums and pails
- Efficiently transfers lubricants to point of application
- Reduces costs over non-bulk methods

### **PORTABLE IN-PLANT GREASE DISPENSE**

- Maintains production machinery
- Mobile equipment maintenance
- Reservoir fill

### **OIL EVACUATION**

- Removes used oils from production machines
- Use in mobile equipment shops
- Pumps oils from storage tanks

### **GREASE AND OIL METERING**

- Metered dispense on production assembly lines
- Applications include:
- Crankcase and transmission fill
  - Filling of machine tool reservoirs
  - Precision bearing lubrication and fill

### **HOSE REELS**

- Improves workflow and tool placement
- Maintenance and production applications
- Cleans and maintains safe storage of air, water and lubricant hose

### **HAND-HELD LUBRICATION**

- Bearing lubrication
- Applications where access is difficult

# Oil and Grease Pumps



## Reliability You Can Trust

When you use a Graco pump, you're looking forward to years of reliable service from the leader in pumping technology.

### **KING®**

Graco's King pumps are designed to handle the demanding production requirements for manufacturing and match your ultra high volume and heavy-duty application needs. Available in ratios ranging from 20:1 to 65:1.

### **BULLDOG®**

Graco Bulldog pumps come with high pressure and high volume pump technology to maximize performance and durability. Available in ratios of 3:1, 5:1, 10:1, 12:1, 14:1, 31:1 and 55:1.

### **FIRE-BALL 425**

With a robust design, the Fire-Ball is the pump of choice for your most demanding high volume applications. Available in ratios of 3:1, 6:1, 10:1, 50:1 and 75:1.

### **FIRE-BALL 300**

Perfect for medium volume applications, the Fire-Ball 300 set the industry standard for years of reliable service. Available in ratios of 5:1, 15:1 and 50:1.

### **MINI FIRE-BALL 225**

Ideal for low to medium volume applications, the Mini Fire-Ball 225 is the latest edition to Graco's classic Fire-Ball design in a new 3:1 package!

### **FAST-BALL®**

Ideal for lower volume short run transfer of oils, the 1:1 Fast-Ball has an in-line design that has fewer parts for minimal pump wear.



King



Bulldog



Fire-Ball 425



Fire-Ball 300



Mini Fire-Ball 225



Fast-Ball

# Portable Grease Systems

## Minimize Your Downtime

Ensure many years of reliable service by keeping your equipment properly lubricated. Without regular lubrication of your plant's equipment, costly downtime and repairs are often the result. Graco can help. Our complete line of portable grease packages offer fast, easy and cost-effective equipment maintenance.



*Portable 35 - 70 lb (16 kg - 32 kg) Pail Cart-Mounted 2-Wheel Metered Dispense Unit.*



*Portable 35 lb (16 kg) Pail Dispense Unit with Carry Handle.*



*Portable 120 lb (55 kg) Package with 2-Wheel Metered Dispense Unit.*



*Portable 120 lb (55 kg) Cart Package With Caster Base.*

*Both metered and unmetered versions of the above packages are available.*



### METERED PACKAGES WITH ACCU-SHOT ELECTRONIC GREASE METER

- Measurement and control of grease delivery
- Oval gear-metering technology
- Advanced electronic controls
- Lightweight aluminum construction
- Easy-to-read and operate



### GREASE DISPENSE PACKAGES WITH THE PRO-SHOT GREASE VALVE

- Pressure-assisted trigger for easy operation
- Simple adjustment for maximum flow capability
- Rugged, ergonomic design with adjustment guard
- Offers years of reliable service

# Metering and Dispense



## Superior Accuracy and Control for Rugged Environments

Graco manufactures a wide range of meters that are ideal for in plant production and maintenance applications where rigorous daily routines demand rugged, accurate dispensing of fluids.

### TYPICAL FLUIDS DISPENSED:

- Motor oils
- Gear oil
- Hydraulic fluid
- ATF
- Grease
- Anti-freeze



*EM5™  
Electronic  
Oil Meter*



*PM5™  
Pre-Set  
Electronic  
Oil Meter*



*EM6™ and EM12™  
Weather-Resistant  
Electronic Oil Meters*



*Accu-Shot™  
Electronic Grease Meter*

### OIL METERS

### GREASE METER

## Fluid Management

Graco's fluid management equipment is perfect for bulk-dispensing of lubricants to production or maintenance areas of the plant. Our systems can be configured for a variety of applications, and will put efficiency in the palm of your hand!

The ProDispense™ electronic preset dispense system quickly dispenses pre-set amounts of oil, grease or water in production environments where accurate dispensing is essential.

The Horizon™ Fluid Management System records fluid dispense, work order numbers, vehicle IDs and mileage to create valuable reports – streamlining your accounting process and maximizing technician efficiency.



# Hose Reels

## The Critical Connection

The right reel is essential for maximizing pump and meter efficiency. That's why we put the same level of craftsmanship into our hose reels as we do in our other lubrication equipment.

We offer a wide range of hose reels capable of handling lubricant oils, grease, air/water, windshield wash or anti-freeze.

**250 SERIES HOSE REEL:** Holds up to 25 ft (7.62 m) of 1/2 in (1.27 cm) hose and can be used in open or enclosed configurations. Heavy-duty springs, bearings and latch bolster reel life. Factory-installed hose stays flexible, even under pressure.

**350 SERIES HOSE REEL:** Handles up to 50 ft (15.24 m) of 1/2 in (1.27 cm) hose to extend coverage area. Includes multi-position hose guide for overhead mounting applications.

**500 SERIES HOSE REEL:** Dual-arm design handles up to 50 ft (15.24 m) of 1/2 in (1.27 cm) hose and includes permanently lubricated bearings for positive recoil and long life. Multi-position roller guide offers superior service in any mounting position.

**700 SERIES HOSE REEL:** Dual-arm design handles up to 75 ft (22.86 m) of 3/4 in (1.91 cm) hose. Equipped with heavy-duty ball bearings for longer life than sleeved-type bearings.

**750 SERIES HOSE REEL:** Heavy-duty, high volume reel handles up to 50 ft (15.2 m) of 1.25 in (3.17 cm) hose that is ideal for fuel dispense. Maintains desired length of hose and assures positive latch and rewind.



250 Series



350 Series



700 Series



500 Series



750 Series

# Transfer Pumps



## Air-Operated Double Diaphragm Pumps

Husky™ Air-Operated Double Diaphragm pumps feature a simple, extremely reliable air valve design that makes the Husky line among the most reliable transfer pumps in a variety of applications.

The unique, patented air valve design has a three-way pilot valve for true non-sticking operation.

### FEATURES:

- Simple, reliable air valves for dependable performance
- No air-line lubrication required, low cost of ownership
- Air valve is serviceable without removing wetted parts

## Air-Operated Piston Pumps

Fast-Ball and Fast-Flo™ 1:1 transfer pumps are designed to operate at air input pressures up to 180 psi (1.2 MPa, 12 bar) and deliver a smooth, reliable flow. Drum length and stubby models are available for either drum transfer or wall mount siphon feed applications.

### FEATURES:

- Air-powered for high reliability and low cost
- Stainless steel and carbon steel options
- Various seal configurations allow a variety of non-corrosive and light corrosive materials to be pumped
- Ball checks or flat check pump configurations are available to accommodate different viscosity materials
- Immersed inlets hold prime better than non-immersed



*Fast-Ball*



*Fast-Flo 1:1*

# Fluid Evacuation

## Quick and Clean Solutions for Your Evacuation Needs

Evacuation and disposal of used oil and related fluids can be a messy and time-consuming job. Fortunately, Graco oil evacuation and used oil equipment provides the perfect solution.

Choose from one of Graco's portable evacuation systems or air-operated double diaphragm pump evacuation packages for draining in-plant machinery.

### TYPICAL FLUIDS EVACUATED:

- Oils
- Coolants
- ATF
- Anti-freeze

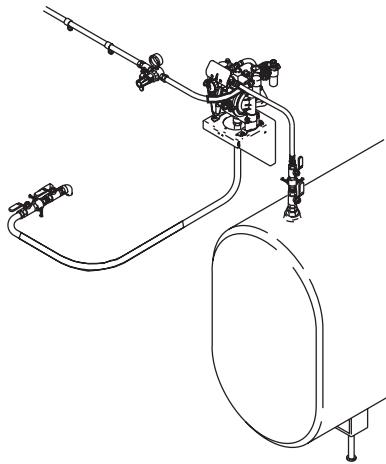
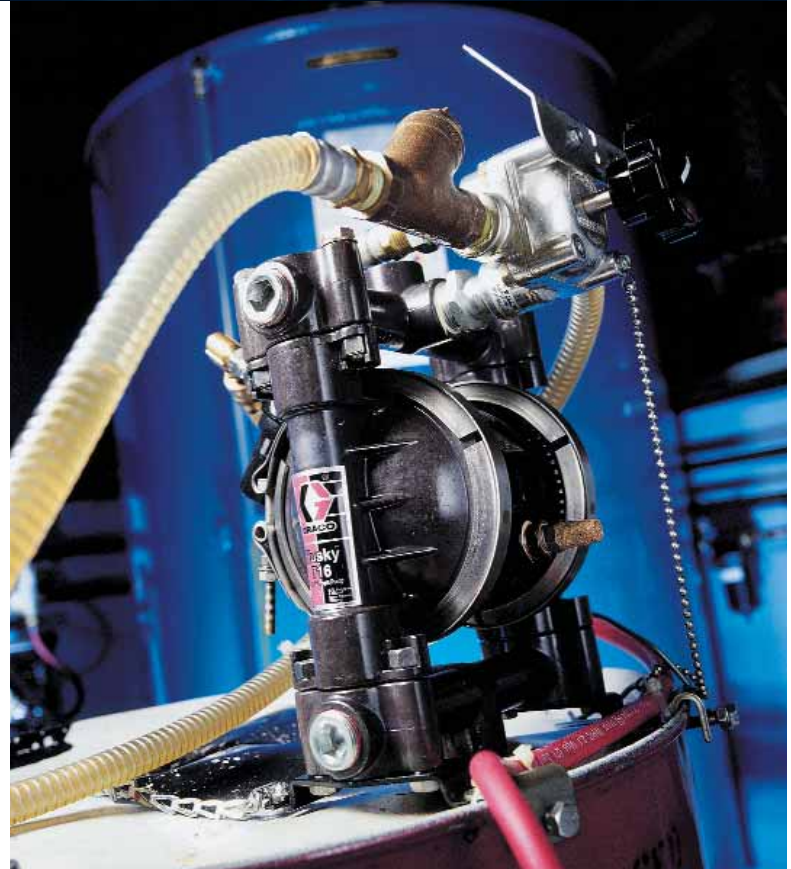

### PACKAGES FOR USED OIL EVACUATION WITH AIR-OPERATED DIAPHRAGM PUMPS:

Includes choice of 1040 or 716 diaphragm pumps, wall bracket, air installation kits, fluid installation kits and drum style adapter kits.

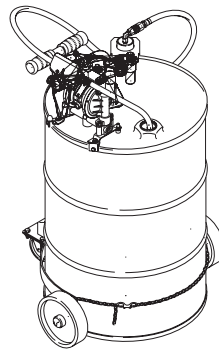

### PORTABLE FAST-VAC EVACUATION SYSTEMS:

Portable 16-gallon system with 16-gallon drum or 55-gallon system without drum. Offers fast and clean withdrawal of fluids. Complete with suction wands to reach the most difficult areas.



### PORT-EVAC PUMP:

Allows fast, clean withdrawal of gear lube, ATF, anti-freeze, and related fluids. Complete with wands to reach even the most difficult areas. Versatile unit can mount on portable tanks and drums.

# Bulk Tanks and Transfer Pumps

## Air-Operated Pumping Systems for Bulk Tanks

Graco caters its in-plant lubrication equipment to the specific configuration of your plant and existing equipment. That's why we offer numerous set-up and installation options in many of our bulk oil or grease packaged solutions.

### MOUNTING AND CONFIGURATION OPTIONS

#### BULK GREASE TOTES

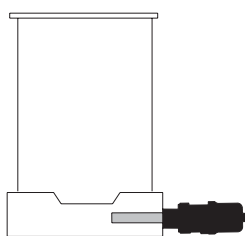

#### HORIZONTAL MOUNT FOR:

Fire-Ball 300, 50:1  
 Fire-Ball 425, 75:1

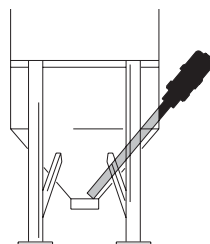

#### SIDE POCKET MOUNT FOR:

Fire-Ball 425, 50:1  
 Fire-Ball 425, 75:1  
 Fire-Ball 300, 50:1

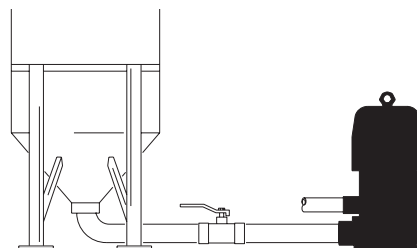

#### FLOOR STANDPIPE MOUNT

Bulldog 3:1	King 24:1
Bulldog 12:1	King 55:1
Bulldog 31:1	King 65:1
Bulldog 55:1	

#### BULK OIL

#### FOR WALL MOUNT, TOP MOUNT OR STAND MOUNT

Fire-Ball 300, 5:1

Fire-Ball 425, 3:1

Bulldog 4:1

Fire-Ball 425, 6:1

Bulldog 10:1

Fire-Ball 425, 10:1

Bulldog 14:1

## Additional Packaged Solutions

The Graco line of Air-Operated pumps are the heart of any lubrication system. Graco pumps provide a wide variety of pressure ratios and tube lengths to fit any application from small portable dispensers to stationary, high-flow, multiple dispense systems.

Consult your local Graco distributor for information and literature on specific mounting and configuration options.



## Hydraulic Pumping Systems for Bulk Tanks

For over 25 years Graco has recommended hydraulic pumps as a more efficient power source. Hydraulics are cleaner to operate while air supply systems can develop rust scale and contaminants from condensed moisture – potentially damaging the pump.

The Dyna-Star™ and the Power-Star hydraulic-operated lubricant pumps are perfect for bulk lubricant transfer.

Choose from wall, tank or bung mount systems.

### FEATURES:

- Continuous and efficient delivery of lubricants
- Long lasting pumps are designed to keep from freezing up in cold weather
- High flow rates over full pressure range
- Self-lubricating for long life and reliability
- Quiet to run with no exhaust noise



# Hand-Held Lubrication



## Putting it All Together

Though often over-looked, systems and accessories are essential when it comes to maximizing pump and meter efficiency. That's why Graco manufactures these components with the same attention to detail as our other lubrication equipment.

### HAND-OPERATED PUMPS

Graco's manually-operated pumps are designed for transferring lubricants out of 5 gallon (20 l), 16 gallon (60 l) or 55 gallon (200 l) drums, or for manually-dispensing grease from 35 lb (15.8 kg) to 120 lb (54 kg) containers to the point of application.

These pumps are perfect for applications where access is often difficult.

### GREASE FITTINGS

Graco offers a wide variety of grease fittings to meet your needs; including styles both with and without ball checks. All fittings are available in either a straight or angled design and include standard threaded, drive-type or button-head fittings. Shank sizes range from 1/8" npt to 9/16" npt.

### GREASE ADAPTERS

All adapters have a lock-sleeve connector for quick connection to any grease nozzle with a tapered-nose coupler. Choose from Hydraulic-to-Push, Hydraulic-to-Steel, Hydraulic-to-Needle, Lock Sleeve Connectors, Easy-Fill Valves and Grease Loader Valves. And, if you're looking for an assortment of adapters, Graco also offers a Hydraulic Adapter Package.



## Easy to Use

### EZ-SHOT™ BATTERY-POWERED GREASE GUN

The EZ-Shot battery-powered grease gun offers measured shot dispense for fast, accurate and verifiable grease dispense. It is ideal for applications in production and maintenance.

#### FEATURES:

- Measured shot (1 cc) grease dispense
- Patented power drive gear
- Lightweight, ergonomic design
- Quick-charge battery
- Unique piston action prevents cavitation and grease contamination
- High-impact, non-corrosive handle and trigger



## Grease Guns

Graco supplies a wide range of durable, hand held grease guns ideal for all your lubrication needs.

### STANDARD PISTOL ACTION GREASE GUN

- 6000 psi (400 bar, 40 MPa) working pressure and 1.8 oz (51 g) per 40 strokes

#### GREASE CONTROL VALVES

- Pro-Shot™ grease dispense valve, max. working pressure 8000 psi (552 bar, 55.2 MPa)
- Power-Shot™ booster gun boosts incoming pressure up to 18,000 psi (1260 bar, 126 MPa)
- Hot-Shot™ portable booster gun has single handle squeeze operation and offers pressures up to 10,000 psi (666 bar, 66.6 MPa)

### STANDARD LEVER-ACTION GREASE GUN

- 6000 psi (400 bar) working pressure and 1.8 oz (51 g) per 40 strokes

### HEAVY-DUTY LEVER-ACTION GREASE GUN

- 2000 to 10,000 psi (138 to 689 bar) working pressure and 1.8 oz (51 g) per 40 strokes

### SUCTION GUN

- For evacuating and filling fluids into gear housings, differential, transmissions and related applications



*Piston Action*



*Standard Lever-Action Grease Gun*



*Heavy-Duty Lever-Action Grease Gun*



*Suction Gun*

# Automatic Lubrication Equipment for Mobile Mining



*GL-1 Series Injector*

## Increase Productivity

Graco has built its reputation on the superior performance of its lubrication equipment, knowledgeable distributor base and solid customer support – increasing productivity and setting a standard in the mining industry.

## GL-1 Series Injector

Designed for single line, parallel automatic lubrication systems, these high pressure injectors are completely interchangeable with competitive injectors of similar size.

### FEATURES:

- Indicator pin offers visual monitoring of operation while cover caps offer protection from external contamination
- Injector outlet adapters for combining the output of additional injectors into a single point of lubrication



*Lubrication Controller*

## Lubrication Controller, 24 Volt

Compact in size and designed with complete monitoring capabilities, the controller has simple menus for programming lubrication equipment at precise time intervals.

### FEATURES:

- Ability to time cycles
- Pressure switch for control and monitoring of system operation
- Alarm indicator light provides system malfunction warning



## Fire-Ball Pump and Reservoir

The Graco 50:1 Fire-Ball grease pump has earned the reputation as the most durable, reliable and highest performing pump of its size in the industry. This high performance assures maximum flow rate capability when dispensing heavy, thick, tacky greases in cold operating conditions.

### FEATURES:

- Long term reliability
- Thick cast aluminum air motor housing
- Lightweight, tough and corrosion-resistant
- Designed to handle wet, dirty air
- Polyurethane u-cup throat-packing with hardened steel displacement rod to minimize wear
- Holds up to 90 lb (40.8 kg) of bulk grease



*Fire-Ball Pump and Reservoir*

## Vent Valve Assembly

All of the necessary components of Graco's air-operated vent valve assembly are preassembled, making it easy to install on a customized bulk grease tank.

### FEATURES:

- Standard vent valve with a 1/2 npsm(f) swivel adapter outlet
- Pressure relief valve
- Pump-mountable air coupler, air line hose, and adapter
- Lubricant vent hose and fitting for return of lubricant to tank
- Mounting bracket for secure and durable installation

Since the Vent Valve Assembly uses standard quality components used on Graco's 90 lb Fire-Ball Pump Module, service and repair kits are readily available.



*Vent Valve Assembly*

# Technical Specifications and Ordering Information

## Meters and Valves

### EM5™ Electronic Meter Specifications

Flow range	0.26 to 5 gpm (1 to 18.9 lpm)
Operating pressure range	
For gear lube units	20 to 1000 psi (1.4 to 70 bar; 0.14 to 7 MPa)
For motor oil units	45 to 1000 psi (3.1 to 70 bar; 0.31 to 7 MPa)
Weight	2.5 lb (1.14 kg)
Units of measurement	quarts, liters, gallons or pints
Inlet	1/2 npt
Outlet	3/8 npt
Operating temperature range	32 to 120°F (0 to 48.8°C)
Battery	9 volt alkaline
Wetted parts	zinc, 304 SST, Zenite®, carbon steel, polyurethane, nitrile rubber
Accuracy	±0.5%

### EM5 Ordering Information

238461	EM5 electronic meter with rigid extension, U.S. measure
238457	EM5 electronic meter with rigid extension, Canadian Weights & Measures Approved (available in Canada only)
238462	EM5 electronic meter with flexible extension, U.S. measure
238458	EM5 electronic meter with flexible extension, Canadian Weights & Measures Approved (available in Canada only)
238463	EM5 electronic meter with gear lube extension, U.S. measure
238459	EM5 electronic meter with gear lube extension, Canadian Weights & Measures Approved (available in Canada only)

### PM5™ Electronic Pre-Set Meter Specifications

Flow range	0.26 to 5 gpm (1 to 18.9 lpm)
Operating pressure range	45 to 1000 psi (2.9 to 70 bar; 0.29 to 7 MPa)
Weight	3 lb (1.36 kg)
Units of measurement	quarts, liters, gallons or pints
Inlet	1/2 npt
Outlet	3/8 npt
Battery	9-volt alkaline
Wetted parts	zinc, 304 SST, Zenite, CS, polyurethane, nitrile rubber
Fluid compatibility	lubricating oils, anti-freeze mixtures
Meter valve assembly pressure loss	17 psi (1.1 bar; 0.11 MPa) [@ 1.5 gpm (5.7 lpm) with 30 wt. oil @ 70°F (21°C)]
Accuracy	±0.5%

### PM5 Ordering Information

238511	PM5 electronic pre-set meter, rigid extension, U.S. measure
238512	PM5 electronic pre-set meter, flexible extension, U.S. measure
238515	PM5 electronic pre-set meter, off-set extension (15° bend with 90° elbow), U.S. measure

### EM6™ Electronic Meter Specifications

Maximum recommended flow rate	.6 gpm (23 lpm)
Maximum operating pressure	1500 psi (103 bar; 10.3 MPa)
Operating temperature range	-4° to 130°F (-20° to 55°C)
Inlet	1/2 npt
Outlet	1/2 npt
Wetted parts	aluminum, SST, CS, acetal, nitrile rubber, Geolast™

### EM6 Ordering Information

243599	EM6 electronic meter with rigid extension, U.S. measure
243600	EM6 electronic meter with gear lube extension, U.S. measure
243601	EM6 electronic meter with flexible extension, U.S. measure
243602	EM6 electronic meter with rigid extension, Metric measure
243603	EM6 electronic meter with gear lube extension, Metric measure
243604	EM6 electronic meter with flexible extension, Metric measure
243992	EM6 electronic meter without locking trigger, 1/2 in (12.7 mm) bare valve

# Technical Specifications and Ordering Information

## Meters and Valves (continued)

### EM12™ Electronic Meter Specifications

Maximum recommended flow rate	12 gpm (45.4 lpm)
Maximum operating pressure	1500 psi (103 bar; 10.3 MPa)
Operating temperature range	-40° to 180°F (-40° to 82°C)
Inlet	1/2 npt and 3/4 npt
Outlet	1/2 npt
Wetted parts	aluminum, SST, CS, acetal, nitrile rubber, Geolast™

### EM12 Electronic Meter Ordering Information

238636	3/4 npt(f) swivel inlet with 1/2 in (12.7 mm) rigid extension, U.S. measure
238637	3/4 npt(f) swivel inlet with 1/2 in (12.7 mm) flexible extension, U.S. measure
238638	3/4 npt(f) swivel inlet with 1/2 in (12.7 mm) rigid extension, Metric measure
238639	3/4 npt(f) swivel inlet with 1/2 in (12.7 mm) flexible extension, Metric measure
238640	1/2 npt(f) swivel inlet with 1/2 in (12.7 mm) rigid extension, U.S. measure
238641	1/2 npt(f) swivel inlet with 1/2 in (12.7 mm) flexible extension, U.S. measure
238642	1/2 npt(f) swivel inlet with 1/2 in (12.7 mm) rigid extension, Metric measure
238643	1/2 npt(f) swivel inlet with 1/2 in (12.7 mm) flexible extension, Metric measure
238647	Bare Valves (No meter or extension) with locking trigger and inline flow-through, 1/2 npt(f) swivel inlet; 1/2 npt(f) outlet
238646	Bare Valves (No meter or extension) with locking trigger and inline flow-through, 3/4 npt(f) swivel inlet; 1/2 npt(f) outlet

### Accu-Shot Electronic Meter Specifications

Dimensions	8.72 in L x 4.43 in H x 1.83 in W (221.5 mm L x 112.5 mm H x 46.5 mm W)
Weight	2.2 lbs (1 kg)
Inlet	1/4 npt(f)
Outlet	1/8 npt(f)
Maximum working pressure	5000 psi (345 bar, 34.5 MPa)
Max working temperature	140°F (60°C)
Flow rate	up to 35.3 oz/min (1000 g/min)
Accuracy	±3
Battery	2 x 1.5 v AA Alkaline (standard alkaline batteries)
Manual	309454

### Accu-Shot Electronic Grease Meter Ordering Information

233807	With battery and rigid extension
245694	With 50:1 Fire-Ball, portable pail dispenser, 35 lbs (15.88 kg)
245695	With 50:1 Fire-Ball, cart-mounted pail dispenser, 35 or 70 lbs (15.88 or 31.76 kg)
245696	With 50:1 Fire-Ball, portable package with two wheel cart, 120 lbs (54.43 kg)

### EZ-Shot Grease Gun Specifications

Dimensions	21.6 in L x 17.0 in H x 2.8 in W (54.9 mm L x 43.2 mm H x 7.1 mm W)
Weight	2.2 lbs (1 kg)
Inlet	1/4 npt(f)
Outlet	1/8 npt(f)
Maximum working pressure	2900 psi (200 bar, 20 MPa)
Max working temperature	32°F to 122°F (0°C to 50°C)
Dispense quantity	1 cc grease per stroke
Grease capacity	400 g (14 oz) standard cartridge 500 g (16 oz) bulk grease
Battery	7.2 V Ni-Cd
Manual	309446

### EZ-Shot Grease Gun Ordering Information

233808	With 20 in (50.8 cm) flexible extension, rechargeable battery and battery charger
--------	---

### Pro-Shot Grease Dispense Valve

242056	1/4 npt(f) inlet with coupler and extension #200389
242055	1/4 npt(f) inlet without coupler or extension
242058	3/8 npt(f) inlet with coupler and extension #200389
242057	3/8 npt(f) inlet without coupler or extension

### Z-Swivel

202577	1/4 npt(m) x 1/4 npt(f)
224569	3/8 npt(m) x 3/8 npt(f)
207948	1/2 npt(m) x 1/2 npt(f)

# Technical Specifications and Ordering Information

## Hose Reels

### 250 Series Technical Specifications

	Low-Pressure	Medium-Pressure	High-Pressure
Inlet	1/2 npsm(m)	1/2 npsm(m)	3/8 npsm(m)
Outlet	1/2 npsm(f)	1/2 npsm(f)	3/8 npsm(f)
Maximum Pressure (bare reel)	1800 psi (124 bar; 12.4 MPa)	1800 psi (124 bar; 12.4 MPa)	8000 psi (552 bar; 55.2 MPa)
Bearings	brass	brass	brass
Wetted Parts	SST, brass, nitrile rubber	CS, brass, nitrile rubber	CS, brass, leather

### 250 Series Ordering Information

#### Low-Pressure Hose Reels (for air or water)

240956\* With 1/2 in x 25 ft (12.7 mm x 7.6 m) hose

240958\* With 1/4 in x 40 ft (6.4 mm x 12.2 m) hose

240959\* With 3/8 in x 40 ft (9.5 mm x 12.2 m) hose

#### Medium-Pressure Hose Reels (for motor oil and light lubricants)

240963\* With 1/2 in x 25 ft (12.7 mm x 7.6 m) hose

#### High-Pressure Hose Reels (for grease)

240967\* With 1/4 in x 35 ft (6.4 mm x 10.6 m) hose

*\*hose inlet kit included*

### 350 Series Technical Specifications

	Low-Pressure	Medium-Pressure	High-Pressure
Inlet	1/2 npt(f)	1/2 npt(f)	1/2 npt(f)
Outlet	1/2 npts(f)	1/2 npsm(f)	3/8 npsm(f)
Maximum pressure (bare reel)	180 psi (12.6 bar; 1.26 MPa)	1800 psi (126 bar; 12.6 MPa)	8000 psi (550 bar; 55 MPa)
Bearings	brass	brass	brass
Wetted parts	SST, nitrile rubber, brass	carbon steel, nitrile rubber, brass	carbon steel, leather, brass

### 350 Series Ordering Information

#### Low-Pressure Hose Reels with Universal Hose Guide (for air or water)

238213 Hose reel with 3/8 in x 60 ft (9.5 mm x 18.3 m)

243983 Hose reel with 1/2 in x 50 ft (12.7 mm x 15.3 m)

#### Medium-Pressure Hose Reels with Universal Hose Guide (for motor oil and light lubricants)

237020 Bare Hose Reel

237021 With 1/2 in x 40 ft (12.7 mm x 12.2 m)

237022 With 1/2 in x 50 ft (12.7 mm x 15.3 m)

#### High-Pressure Hose Reels (for grease)

237030 Bare Hose Reel

237032 With 1/4 in x 50 ft (6.4 mm x 15.3 m)

237034 With 3/8 in x 50 ft (9.5 mm x 15.3 m)

# Technical Specifications and Ordering Information

## Hose Reels

### 500 Series Technical Specifications

	Low- and Medium-Pressure	High-Pressure
Inlet	1/2 npsm(m)	3/8 npsm(m)
Outlet	1/2 npsm(f)	3/8 npsm(f)
Maximum pressure (bare reel)	(124 bar; 12.4 MPa)	1800 psi (552 bar; 55.2 MPa) 8000 psi
Bearings	oil-impregnated bronze	oil-impregnated bronze
Wetted Parts	carbon steel, nitrile rubber, polyester elastomer	carbon steel, nitrile rubber, polyester elastomer

### 500 Series Ordering Information

#### Low-Pressure Hose Reels (for air or water)

- 224050 Bare Hose Reel
- 224051 With 3/8 in x 60 ft (9.5 mm x 18.3 m) hose
- 243982 With 1/2 in x 50 ft (12.7 mm x 15.3 m) hose

#### Medium-Pressure Hose Reels (for motor oil and light lubricants)

- 224050 Bare Hose Reel
- 206941 Dual Hose Reel (Bare Reel)
- 224058 With 1/2 in x 50 ft (12.7 mm x 15.3 m) hose

#### High-Pressure Hose Reels (for grease)

- 224060 Bare Hose Reel
- 224055 With 1/4 in x 50 ft (6.4 mm x 15.3 m) hose
- 224056 With 3/8 in x 50 ft (9.5 mm x 15.3 m) hose

### 700 Series Technical Specifications

	Medium-Pressure
Inlet	1 npsm(f)
Outlet	1 npsm(f)
Max. pressure (bare reel)	1500 psi (103 bar; 10.3 MPa)
Bearings	self-aligning, sealed ball bearings (steel alloy)
Wetted Parts	carbon steel, Viton®

### 700 Series Ordering Information

#### Medium-Pressure Oil Dispense Reels rated to 1500 psi (103 bar; 10.3 MPa)

- 237728 Bare hose reel
- 237875 With 1/2 in x 75 ft (12.7 mm x 23 m) hose
- 237881 With 3/4 in x 50 ft (19.1 mm x 15 m) hose
- 237879 With 3/4 in x 75 ft (19.1 mm x 23 m) hose

#### Medium-Pressure Oil Evacuation and Dispense Reels rated to 212 psi (14.6 bar; 1.46 MPa)

- 241909 Hose reel with 1 in x 30 ft (25.4 mm x 9 m) hose; 24 in (0.3 m) Hg vacuum
- 241910 Hose reel with 1 in x 50 ft (25.4 mm x 15 m) hose; 24 in (0.3 m) Hg vacuum

#### Medium-Pressure Fuel Dispense Reels rated to 125 psi (8.6 bar; 0.86 MPa)

- 237884 Hose reel with 1 in x 50 ft (25.4 mm x 15 m) hose

### 750 Series Technical Specifications

	Medium-Pressure
Inlet	1-1/2 npt(f)
Outlet	1-1/2 npt(f)
Max. pressure (bare reel)	375 psi (26 bar; 2.6 MPa)
Working temperature	150°F (65°C)
Weight	125 lbs (57 kg)
Hose capacity (not included)	50 ft (15.2 m) x 1.25 in ID Hose

### 750 Series Ordering Information

#### Medium-Pressure Hose Reels (for high volume applications)

- 245410 Bare Hose Reel

# Technical Specifications and Ordering Information

## Diaphragm Pumps Quick Reference Chart

Body/Diaphragm Description	Part Number	Ratio	Max Air psi (bar; MPa)	Free Flow Rate gpm (lpm)	Air Consumption SCFM	Fluid Inlet/Outlet NPT
307 3/8 in (9.52 mm) Acetal/Hytrel	D31255	1:1	100 (7; 0.7)	7 (31.8)	7	3/8
515/716 3/4 in (19.05 mm) Aluminum/Buna-N	241906	1:1	100 (7; 0.7)	16 (60.6)	28	3/4
Acetal/Buna Dual Inlet	243669	1:1	100 (7; 0.7)	16 (60.6)	28	3/4
1040 1 in (25.4 mm) Aluminum/Hytrel	D73525	1:1	120 (8.3; 0.8)	40 (151.4)	40	1
Aluminum/Hytrel (UL)	236265	1:1	120 (8.3; 0.8)	40 (151.4)	40	1
(1) Aluminum/Hytrel (UL)	236267	1:1	50 (3.4; 0.3)	20 (75.7)	20	1
1590 1-1/2 in (38.1 mm) Aluminum/Hytrel	DB3525	1:1	120 (8.3; 0.8)	90 (341.0)	90	1-1/2
2150 2 in (50.8 mm) Aluminum/Hytrel	DF3525	1:1	120 (8.3; 0.8)	150 (567.6)	175	2
3275 3 in (76.2 mm) Aluminum/Hytrel	DK3525	1:1	120 (8.3; 0.8)	275 (1,041.0)	325	3

(1) For use with leaded fuel

## Transfer Pumps Quick Reference Chart

Model	55 gal (200 l) Bung Mt.	275 gal (1040 l) Bung Mt.	Max Fluid Outlet Pressure psi (bar)	Continuous Flow Rate gpm (lpm)	Air Consumption @ 100 psi (7 bar, 0.7 MPa)	Maximum Line Length ft (m)
Fast-Ball® 1:1	222051	222103	22104	180 (12.4)	4 to 5 (18.2 to 22.7)	7 cfm (30.5)
Fast-Flo® UL-Approved 1:1	226944	226941	N/A	180 (12.4)	4 to 5 (18.2 to 22.7)	7 cfm (30.5)
Fast-Flo Stainless Steel; UL-Approved 1:1	226945	226942	N/A	180 (12.4)	4 to 5 (18.2 to 22.7)	7 cfm (30.5)

## **OIL** Fire-Ball OIL Pump Family Specifications

Note: Data measured with 10 weight oil @ 70°F (21°C).

Model Name	Mini Fire-Ball 225	Fire-Ball 300	Fire-Ball 425	Fire-Ball 425	Fire-Ball 425
Ratio	3:1	5:1	3:1	6:1	10:1
Cycles/Gallon (cycles/liter)	43.5 (11.4)	28.4 (8.6)	6 (1.6)	12 (3.2)	19.6 (5.2)
Fluid Flow @ 80 cpm (gpm/lpm)	1.84 gpm (7.0 lpm)	2.8 gpm (9.3 lpm)	13.4 gpm (50.6 lpm)	6.6 gpm (25.3 lpm)	4.1 gpm (15.4 lpm)
Pumping Distance Guideline	Up to 250 ft (76.2 m)	Up to 500 ft (152.5 m)	Up to 250 ft (76.2 m)	Up to 500 ft (152.5 m)	Up to 750 ft (228.6 m)
Maximum Fluid Pressure	540 (37 bar, 3.7 MPa)	900 (62 bar, 6.2 MPa)	540 (37 bar, 3.7 MPa)	1100 (76 bar, 7.6 MPa)	1800 (124 bar, 12.4 MPa)
Air Motor Diameter	2.25 in (57.2 mm)	3.0 in (76.2 mm)	4.25 in (107.9 mm)	4.25 in (107.9 mm)	4.25 in (107.9 mm)
Air Operating Range	40–180 psi (2.8–12 bar, 0.3–1.2 MPa)	40–180 psi (2.8–12 bar, 0.3–1.2 MPa)	40–180 psi (2.8–12 bar, 0.3–1.2 MPa)	40–180 psi (2.8–12 bar, 0.3–1.2 MPa)	40–180 psi (2.8–12 bar, 0.3–1.2 MPa)
Air Consumption and Fluid Flow @ 100 psi air and 80 cpm (scfm-gpm and m3/liter-lpm)	8.5 scfm @ 2.1 gpm (.24m3/min@7.9 lpm)	27.0 scfm @ 3 gpm (.77m3/min@11.5 lpm)	58.0 scfm @ 13.4 gpm (1.64m3/min@50.6 lpm)	49.5 scfm @ 6.8 gpm (.33m3/min@25.7 lpm)	32 scfm @ 4.1 gpm (.56m3/min@15.4 lpm)
Dry Suction Lift (inches of 10 weight oil)	23	26	26	23	26
Wetted Materials	Steel, Polyurethane, Aluminum, Buna-N, Rulon™	Steel, Polyurethane, Aluminum, Nitrile Chrome	Steel, Polyurethane, Aluminum, Nitrile	Steel, Polyurethane, Aluminum, Nitrile	Steel, Polyurethane, Aluminum, Nitrile
Air Inlet Port Size, npt (f)	3/8"	3/8"	1/2"	1/2"	1/2"
Fluid Inlet Port Size, npt (f)	1-1/2"	1-1/2"	1-1/2"	1-1/2"	1-1/2"
Fluid Outlet Port Size, npt (f)	1/2"	1/2"	3/4"	3/4"	3/4"
Sound Pressure, measured at 1 meter from unit (dB)	77.8	77.8	80.85	80.85	80.85
Sound Power, tested in accordance with ISO 9614-2 (dB)	85.6	85.6	94.62	94.62	94.62
Typical Oil Volume Pumped Per Year	6,500 gal (24,602 l)	30,000 gal (113,550 l)	30,000 gal or more (113,550 l)	30,000 gal or more (113,550 l)	30,000 gal or more (113,550 l)

# Technical Specifications and Ordering Information

## Fire-Ball 225 Packages

	Portable Package	Cover-Mounted Package	Cover-Mounted Package	Bung-Mounted Package	Bung-Mounted Package	Universal Package
Ratio	3:1	3:1	3:1	3:1	3:1	3:1
Container Size	16 gal (60 l)	16 gal (60 l)	55 gal (200 l)	55 gal (200 l)	275 gal (1040 l)	Universal
Fire-Ball 225 Package No.	<b>246903†</b>	<b>246904†</b>	<b>246906†</b>	<b>246907*†</b>	<b>246907*†</b>	<b>248230*†</b>
Fire-Ball 225 Bare Pump	248097	248097	248097	248097	248097	246775
Dispense/Hose Fitting Kit	237075	222063	222063	222063	222063	222062
Fluid Hose	6 ft x 1/2 in (1.8 m x 12.7 mm)	6 ft x 1/2 in (1.8 m x 12.7 mm)	6 ft x 1/2 in (1.8 m x 12.7 mm)	6 ft x 1/2 in (1.8 m x 12.7 mm)	6 ft x 1/2 in (1.8 m x 12.7 mm)	1.5 ft x 1/2 in (0.5 m x 12.7 mm)
Air Hose	—	6 ft x 3/8 in (1.8 m x 9.5 mm)	6 ft x 3/8 in (1.8 m x 9.5 mm)	6 ft x 3/8 in (1.8 m x 9.5 mm)	6 ft x 3/8 in (1.8 m x 9.5 mm)	1.5 ft x 3/8 in (0.5 m x 9.5 mm)
Air Regulator	224512	224512	224512	—	—	—
Cover	204574	204574	200326	—	—	—
Bung Adapter	—	—	—	222308	222308	—
Caster Base	203622	—	—	—	—	—
Instruction Manual	309868	309868	309868	309868	309868	309868

\* Use 3/8 in (9.5 mm) air regulator 109075 as required; must be ordered separately

† Order low-level cut-off 203688 separately for metered dispense systems

## Fire-Ball 300 Packages

	Portable Package	Cover-Mounted Package	Cover-Mounted Package	Bung-Mounted Package	Bung-Mounted Package	Universal Package
Ratio	5:1	5:1	5:1	5:1	5:1	5:1
Container Size	16 gal (60 l)	16 gal (60 l)	55 gal (200 l)	55 gal (200 l)	275 gal (1040 l)	Universal
Fire-Ball 300 Package No.	<b>225728†</b>	<b>225094†</b>	<b>225642†</b>	<b>225640*†</b>	<b>225931*†</b>	<b>225852*†</b>
Fire-Ball 300 Bare Pump	203872	203872	203857	204254	222087	203876
Dispense/Hose Fitting Kit	237075	222063	222063	222063	222063	222062
Fluid Hose	6 ft x 1/2 in (1.8 m x 12.7 mm)	6 ft x 1/2 in (1.8 m x 12.7 mm)	6 ft x 1/2 in (1.8 m x 12.7 mm)	6 ft x 1/2 in (1.8 m x 12.7 mm)	6 ft x 1/2 in (1.8 m x 12.7 mm)	1.5 ft x 1/2 in (0.5 m x 12.7 mm)
Air Hose	—	6 ft x 3/8 in (1.8 m x 9.5 mm)	6 ft x 3/8 in (1.8 m x 9.5 mm)	6 ft x 3/8 in (1.8 m x 9.5 mm)	6 ft x 3/8 in (1.8 m x 9.5 mm)	1.5 ft x 3/8 in (0.5 m x 9.5 mm)
Air Regulator	224512	224512	224512	—	—	—
Cover	204574	204574	200326	—	—	—
Bung Adapter	—	—	—	222308	222308	—
Caster Base	203622	—	—	—	—	—
Instruction Manual	307884	307883	307883	307883	307883	306520

\* Use 3/8 in (9.5 mm) air regulator 109075 as required; must be ordered separately

† Order low-level cut-off 203688 separately for metered dispense systems

## Fire-Ball 425 Packages

	Wall Mount Package	Wall Mount Package	Wall Mount Package	Cover-Mounted Package	Bung-Mounted Package	Universal Supply Package
Ratio	3:1	6:1	10:1	10:1	10:1	10:1
Container Size	—	—	Universal	55 gal (200 l)	55 gal (200 l)	Universal
Package No.	<b>244846</b>	<b>244628</b>	<b>244847</b>	<b>225782*†</b>	<b>225786*†</b>	<b>225853*†</b>
Pump No.	237526	238108	205626	222065	222095	205626
Hose/Fitting Kit	222068	222068	222068	222066	222066	222068
Fluid Hose	1.5 ft x 3/4 in (0.5 m x 19.05 mm)	1.5 ft x 3/4 in (0.5 m x 19.05 mm)	1.5 ft x 3/4 in (0.5 m x 19.05 mm)	6 ft x 3/4 in (1.8 m x 19.05 mm)	6 ft x 3/4 in (1.8 m x 19.05 mm)	1.5 ft x 3/4 in (0.5 m x 19.05 mm)
Air Hose	1.5 ft x 1/2 in (0.5 m x 12.7 mm)	1.5 ft x 1/2 in (0.5 m x 12.7 mm)	1.5 ft x 1/2 in (0.5 m x 12.7 mm)	6 ft x 1/2 in (1.8 m x 12.7 mm)	6 ft x 1/2 in (1.8 m x 12.7 mm)	1.5 ft x 1/2 in (0.5 m x 12.7 mm)
Cover	—	—	—	200326	—	—
Air Filter/Regulator	217072	217072	217072	—	—	—
Air Shutoff Valve	110225	110225	110225	—	—	—
Fluid Shutoff Valve	108537	108537	108537	—	—	—
Wall Mount Bracket	238245	238245	238245	—	—	—
Instruction Manual	309351	309351	309351	307883	307883	306520

\* Use 1/2 in (12.7 mm) air regulator/gauge 244844 as required; must be ordered separately

† Order low-level cut-off 203688 separately for metered dispense systems

# Technical Specifications and Ordering Information

## Fire-Ball 300 and 425 Lube Truck packages

	Fire-Ball 300 Cover-Mounted Package	Fire-Ball 300 Cover-Mounted Package	Fire-Ball 300 Bung-Mounted Package	Fire-Ball 425 Cover-Mounted Package	Fire-Ball 425 Bung-Mounted Package
Ratio	5:1	5:1	5:1	10:1	10:1
Container Size	16 gal (60 l)	55 gal (200 l)	55 gal (200 l)	55 gal (200 l)	55 gal (200 l)
	Open-head	Open-head	Closed-head †	Open-head	Closed-head †
Package No.	<b>222086</b>	<b>206655</b>	<b>204264</b>	<b>206656</b>	<b>222067</b>
Bare Pump No.	203872	203857	204254	222065	222095
Hose/Fitting Kit	222063	222063	222063	222066	222066
Hose Length	6 ft (1.8 m)	6 ft (1.8 m)	6 ft (1.8 m)	6 ft (1.8 m)	6 ft (1.8 m)
Air Regulator	*	*	*	**	**
Hold-Down Kit	222061	207361	207361	207361	207361
Drum Cover	222060	207367	–	207367	–
Bung Adapter	–	–	204076	–	224579
Pump Clamp	–	–	204095	–	204095
Instruction Manual	307883	307883	307883	307883	307883

† For closed-head drums, pump mounts off-center on drum cover. Pump draws through standard 2 npt bung opening and is equipped with grommet for rain-tight seal to the drum cover

\* Use 3/8 in (9.5 mm) air regulator 109075; must be ordered separately

\*\* Use 1/2 in (12.7 mm) air regulator 244844; must be ordered separately

## GREASE

### Fire-Ball GREASE Pump Family Specifications

Note: Tested in NLGI #1 grease @ 70°F (21°C)

Model Name	Fire-Ball 300	Fire-Ball 300	Fire-Ball 425	Fire-Ball 425	Fire-Ball 425
Ratio	15:1	50:1	50:1	75:1	10:1
Dispense Points	1-2	1-2	4 or more	4 or more	Grease Transfer
Cycles/Pound (cycles/kilogram)	12.4 (27.3)	43.5 (100.0)	15.0 (33.4)	23.8 (52.3)	3.4 (7.4)
Cycles/Gallon (cycles/liter)	90.0 (23.8)	345.0 (91.0)	119.0 (72.5)	23.5 (6.2)	3.4 (7.4)
Air Motor Effective Diameter	3.0 in (76.2 mm)	3.0 in (76.2 mm)	4.25 in (107.9 mm)	4.25 in (107.9 mm)	4.25 in (107.9 mm)
Air Operating Range	40-180 psi (2.8–12 bar, 0.3–1.2 MPa)	30–140 psi (2–9.6 bar, 0.2–0.9 MPa)	40–150 psi (2.8–12 bar, 0.3–1.2 MPa)	40–100 psi (2.8–7 bar, 0.3–0.7 MPa)	40-180 (2.8–12 bar, 0.3–1.2 MPa)
Maximum Fluid Pressure	2700 psi (186 bar, 18.6 MPa)	8400 psi (578 bar, 57.8 MPa)	7500 psi (517 bar, 51.7 MPa)	7500 psi (517 bar, 51.7 MPa)	1800 psi (124 bar, 12.4 MPa)
Wetted Materials	Steel, Brass, Copper, Aluminum, Leather, PTFE, Nitrile Rubber	Steel, Brass, Aluminum, Delrin, Nitrile, Rubber Polyurethane	Steel, Brass, Aluminum, Leather	Steel, Brass, Aluminum, Leather	Steel, Brass, Aluminum, Leather, Buna-N
Approximate Air Consumption (scfm, m3/min)	17 (0.48) @ 1 gpm (7.3 lb/min – .45 kg/min) @ 100 psi (7 bar, 0.7 MPa) air pressure	22.8 (0.65) @ .25 gpm (1.8 lb/min – .83 kg/min) @ 100 psi (7 bar, 0.7 MPa) air pressure	19 (0.54) @ 1 gpm (7.3 lb/min – .45 kg/min) @ 70 psi (4.8 bar, 0.5 MPa) air pressure	26 (0.74) @ 1 gpm (7.3 lb/min – .45 kg/min) @ 70 psi (4.8 bar, 0.5 MPa) air pressure	13 (0.39) @ 1 gpm (7.3 lb/min – .45 kg/min) @ 70 psi (4.8 bar, 0.5 MPa) air pressure
Air Inlet Port Size, npt(f)	3/8"	3/8"	1/2"	1/2"	1/2"
Fluid Outlet Port Size, npt(f)	1/4"	1/4"	3/8"	3/8"	3/8"
Sound Pressure, measured at 1 meter from unit (dB)	77.8	77.8	80.85	80.85	80.85
Sound Power, tested in accordance with ISO 9614-2 (dB)	85.6	85.6	94.62	94.62	94.62
Annual Grease Usage	up to 10,000 lb (4,535 kg)	up to 10,000 lb (4,535 kg)	10,000 lb or more (4,535 kg)	10,000 lb or more (4,535 kg)	Transfer

# Technical Specifications and Ordering Information

## Fire-Ball 300 packages – For 35-70 lb (16 kg) Containers

	Portable Pail Dispenser	Stationary Pail Dispenser	Cart-Mounted Pail Dispenser	Cart-Mounted Pail Topper
Ratio	50:1	50:1	50:1	50:1
Container Size	35 lb (16 kg)	35 lb or 70 lb (16 kg or 32 kg)	35 lb or 70 lb (16 kg or 32 kg)	35 lb (16 kg)
Fire-Ball 300 Package No.	<b>222069*</b>	<b>225827*</b>	<b>225773*</b>	<b>226012*</b>
Metered Package**	<b>245694</b>	–	<b>245695</b>	–
Pump No.	239877	239877	239877	239877
Dispense Kit	222070	222070	222070	222070
Fluid Hose	12 ft x 1/4 in (3.7 m x 6.4 mm)	12 ft x 1/4 in (3.7 m x 6.4 mm)	12 ft x 1/4 in (3.7 m x 6.4 mm)	12 ft x 1/4 in (3.7 m x 6.4 mm)
Air Hose	–	–	–	–
Follower Plate	220653	†	†	–
Cover	222059	204574	204574	–
Holster	–	203976	203976	203976
Container	–	204134	204134	–
Cart	–	–	203650	203650
Elevator	–	–	–	203664
Inductor Plate	–	–	–	204351
Instruction Manual	307878	307878	307878	307878

\* Use 3/8 in (9.5 mm) air regulator 109075; must be ordered separately

\*\* Metered grease package includes 233807 Accu-Shot instead of 242056 Pro-Shot

† Order follower plate 220653 for 35 lb (16 kg) containers, and follower plate 220654 for 70 lb (32 kg) containers; must be ordered separately

## Fire-Ball 300 packages – For 120 lb (55 kg) Containers

	Portable Package w/Caster Base	Portable Package w/Two-Wheel Cart	Portable Package w/Heavy-Duty Cart	Stationary Supply Package	Stationary Supply Topper-Inductor Package
Ratio	50:1	50:1	50:1	50:1	50:1
Container Size	120 lb (55 kg)	120 lb (55 kg)	120 lb (55 kg)	120 lb (55 kg)	120 lb (55 kg)
Fire-Ball 300 Package No.	<b>225006*</b>	<b>225026*</b>	<b>222245*</b>	<b>225014*</b>	<b>222073*</b>
Metered Package	–	<b>245696**</b>	–	–	–
Pump No.	239887	239887	239887	239887	239887
Hose Kit	222070	222070	222383	222072	–
Fluid Hose	12 ft x 1/4 in (3.7 m x 6.4 mm)	12 ft x 1/4 in (3.7 m x 6.4 mm)	25 ft x 1/4 in (7.6 m x 6.4 mm)	6 ft x 1/4 in (1.8 m x 6.4 mm)	6 ft x 1/4 in (1.8 m x 6.4 mm)
Air Hose	–	–	–	6 ft x 3/8 in (1.8 m x 9.5 mm)	6 ft x 3/8 in (1.8 m x 9.5 mm)
Follower Plate	220654	220654	220654	220654	–
Cover	204574	204574	222060	204574	–
Holster	203976	203976	–	–	–
Caster Base	203622	–	–	–	–
Cart	–	203650	222243	–	–
Elevator	–	–	–	–	204121
Pump Support	–	–	–	–	222074†
Hold Down Kit	–	–	222061	–	–
Instruction Manual	307878	307878	307878	307880	306523

\* Use 3/8 in (9.5 mm) air regulator 109075; must be ordered separately

\*\* Metered grease package includes 233807 Accu-Shot instead of 242056 Pro-Shot

† Pump support assembly includes dust cover, base, indicator plate plate and 6 ft (1.8 m) fluid and air hose

## Technical Specifications and Ordering Information

### Fire-Ball 300 Packages – For pourable GREASE

	Stationary Pail Dispenser	Stationary Drum Dispenser	Cover-Mounted Drum Dispenser
Ratio	15:1	15:1	15:1
Drum Size	35 lb (16 kg)	120 lb (55 kg)	400 lb (180 kg)
Package No.	<b>222078</b>	<b>220170</b>	<b>220171</b>
Pump No.	206405	206699	206700
Dispense Kit	222080	222081	222081
Fluid Hose	15 ft x 3/8 in (4.6 m x 9.5 mm)	25 ft x 3/8 in (7.6 m x 9.5 mm)	25 ft x 3/8 in (7.6 m x 9.5 mm)
Drum Cover	222058	204574	200326
Instruction Manual	307882	307882	307882

### Fire-Ball 300 Packages – for 400 lb (180 kg) Containers

	Stationary Package	Topper-Inductor Package
Ratio	50:1	50:1
Container Size	400 lb (180 kg)	400 lb (180 kg)
Fire-Ball 300 Package No.	<b>225016*</b>	<b>226013*</b>
Pump No.	239888	239888
Hose & Fitting Kit	222072	204467
Fluid Hose	6 ft (1.8 m) x 1/4 in (6.4 mm)	6 ft (1.8m) x 1/4 in (6.4 mm)
Air Hose	6 ft (1.8 m) x 3/8 in (9.5 mm)	6 ft (1.8m) x 3/8 in (9.5 mm)
Follower Plate	223845	–
Cover	200326	–
Carriage	–	204461
Elevator	–	204385
Inductor Plate	–	204353
Base	–	205339
Instruction Manual	307880	306556

\* Use 3/8 in (9.5 mm) air regulator 109075; must be ordered separately

### Fire-Ball 425 Packages

	Stationary Supply Package	Stationary Supply Package	Stationary Topper-Inductor Package	Ram Package
Ratio	50:1	50:1	50:1	50:1
Container Size	120 lb (55 kg)	400 lb (180 kg)	400 lb (180 kg)	400 lb (180 kg)
Package No.	<b>223108*</b>	<b>225781*</b>	<b>226018*</b>	<b>244905</b>
Pump No.	205394	205395	205395	205395
Hose Kit	222076	222076	205102	222076
Fluid Hose	6 ft x 3/8 in (1.8 m x 9.5 mm)	6 ft x 3/8 in (1.8 m x 9.5 mm)	6 ft x 3/8 in (1.8 m x 9.5 mm)	6 ft x 3/8 in (1.8 m x 9.5 mm)
Air Hose	6 ft x 1/2 in (1.8 m x 12.7 mm)	6 ft x 1/2 in (1.8 m x 12.7 mm)	6 ft x 1/2 in (1.8 m x 12.7 mm)	6 ft x 1/2 in (1.8 m x 12.7 mm)
Cover	204574	200326	–	–
Follower Plate	223344	223846	–	–
Carriage	–	–	204461	–
Elevator	–	–	204385	–
Inductor Plate	–	–	205699	–
Base	–	–	205339	–
Ram	–	–	–	207279
Air Regulator	–	–	–	244844
Adapter Plate	–	–	–	162225
Adapter Kit	–	–	–	224266
Pump Mounting Kit	–	–	–	224829
Instruction Manual	307880	307880	306556	309345

\* Use 1/2 in (12.7 mm) air regulator/gauge 244844; must be ordered separately

# Technical Specifications and Ordering Information

## Fire-Ball 425 Packages

	Cover-Mounted Package	Cover-Mounted Package	Inductor Package	Ram Package	Pail Length 35/70 lb	400 lb (180 kg) Bung or Cover
Ratio	75:1	75:1	75:1	75:1	75:1	10:1
Container Size	120 lb (55 kg)	400 lb (180 kg)	400 lb (180 kg)	400 lb (180 kg)	Pail Length	400 lb (180 kg)
Package	<b>244635*</b>	<b>244636*</b>	<b>244637*</b>	<b>244906</b>	<b>NA</b>	<b>NA</b>
Bare pump no.	239729	239730	239730	239730	239731	965129
Hose and Fitting Kit	222076	222076	205102	222076	–	–
Drum Cover	204574	200326	–	–	204574	–
Follower Plate	223344	223846	–	–	**	–
Carriage	–	–	204461	–	–	–
Elevator	–	–	204385	–	–	–
Base	–	–	205339	–	–	–
Inductor	–	–	205699	–	–	–
Ram	–	–	–	207279	–	–
Air Regulator	–	–	–	244844	–	–
Adapter Plate	–	–	–	162225	–	–
Adapter Kit	–	–	–	224266	–	–
Pump Mounting Kit	–	–	–	224829	–	–
Instruction Manual	307880	307880	306556	309345	–	–

\* Use 1/2 in (12.7 mm) air regulator and gauge 244844; must be ordered separately

\*\* 35 lb: 200653 / 70 lb: 223344

## Fire-Ball 300 and 425 Lube Truck packages

	Fire-Ball 300 Cover-Mounted Package	Fire-Ball 300 Cover-Mounted Package	Fire-Ball 425 Cover-Mounted Package	Fire-Ball 425 Cover-Mounted Package	Fire-Ball 425 Cover-Mounted Package	Fire-Ball 425 Cover-Mounted Package
Ratio	50:1	50:1	50:1	50:1	75:1	75:1
Container Size	120 lb (55 kg)	400 lb (180kg)	120 lb (55 kg)	400 lb (180 kg)	120 lb (55 kg)	400 lb (180 kg)
	Open-head	Open-head	Open-head	Open-head	Open-head	Open-head
Package No.	<b>222085</b>	<b>222071</b>	<b>223107</b>	<b>222075</b>	<b>243817</b>	<b>243818</b>
Bare Pump No.	239887	239888	205394	205395	239729	239730
Hose/Fitting Kit	222072	222072	222076	222076	222076	222076
Hose Length	6 ft (1.8 m)	6 ft (1.8 m)	6 ft (1.8 m)	6 ft (1.8 m)	6 ft (1.8 m)	6 ft (1.8 m)
Air Regulator	*	*	**	**	**	**
Hold-Down Kit	222061	207361	222061	207361	222061	207361
Drum Cover	222060	207366	222060	207366	222060	207366
Follower Plate	220654	223845	223344	223846	223344	223846
Instruction Manual	307880	307880	307880	307880	307880	307880

\* Order 3/8 in (9.5 mm) air regulator and gauge separately, 109075

\*\* Order 1/2 in (12.7 mm) air regulator and gauge separately, 244844

# Technical Specifications and Ordering Information

## Bulk Transfer Quick Reference Matrix

### Air Operated Transfer Packages for Bulk Grease Totes

Description	12:1 Bulldog Stand Mount	31:1 Bulldog Stand Mount	3:1 Bulldog Stand Mount	55:1 Bulldog Stand Mount	24:1 King Stand Mount	55:1 King Stand Mount	65:1 King Stand Mount	Hydraulic Viscount II Stand Mount
Package No.	244649	244650	244651	244652	244653	244654	244655	244656

\*Package includes pump, air connect hose, fluid connect hose, air shut-off valve, air regulator kit, mounting/connection kit and floor stand.

### Air Operated Transfer Packages for Bulk Grease Totes

Description	50:1 Fire-Ball Side Pocket Mount	50:1 Fire-Ball Horizontal Mount	50:1 President Side Pocket Mount	75:1 President Side Pocket Mount	75:1 President Horizontal Mount
Package No.	244644	244645	244646	244647	244648

\*Package includes pump, air shut-off valve, fluid shut-off valve, hose and fitting kit, air regulator kit, flange adapter and flange coupler.

### Air Operated Transfer Packages for Bulk Grease Drums

Description	65:1 King Ram 400 lb. (181 kg) drum	55:1 Bulldog Ram 400 lb. (181 kg) drum	12:1 Bulldog Ram 400 lb. (181 kg) drum	3:1 Bulldog Ram 400 lb. (181 kg) drum	3:1 Bulldog Sinker 400 lb. (181 kg) drum	Hydraulic 5:1 Dyna-Star® 120 lb. (55 kg) drum	5:1 Dyna-Star 400 lb. (181 kg) drum
Package No.	244638	244639	244640	244641	244848	244642	244643

\*Package includes pump, air connect hose, fluid connect hose, hydraulic fluid controls, drum cover, follower plate/inductor or ram, air regulator kit and drum clamp.

### Air Operated Bulk Oil Transfer Packages

Description	4:1 Bulldog Floor Stand	5:1 Bulldog Wall Mount	10:1 Bulldog Floor Stand	10:1 Bulldog Wall Mount	14:1 Bulldog Floor Stand	20:1 King Wall Mount
Package No.	241360	244629	241361	244630	241362	244631

\*Package includes pump, filter, regulator, lubricator, air connect hose, fluid connect hose, air shut-off valve, fluid shut-off and wall mount bracket or floor stand.

### Hydraulic Operated Bulk Oil Transfer Packages

Description	1:1 Dyna-Star Wall Mount	1/4:1 Dyna-Star Wall Mount	1:1 Powerstar Wall Mount	1:1 Dyna-Star 55 Gal. (200 l) Bung Mount
Package No.	244632	244633	244634	244678

\*Package includes pump, fluid connect hose, fluid shut-off, hydraulic fluid controls and wall mount bracket or bung adapter.

### Air Operated Bulk Anti-Freeze and Windshield Solvent Transfer Packages

Description	1040 AAOD Dual Inlet	1040 AODD Single Inlet	716 AODD Dual Inlet	716 AODD Single Inlet
Package No.	244679	224680	244681	244682

\*Package includes pump, air regulator, fluid connect hose, air connect hose, air-shut-off valve, wall mount bracket, inlet manifold, suction kit and thermal relief kit.

\*For a list of components included with each package, refer to Buyers Guide, 303245

# Technical Specifications and Ordering Information

## Automatic Lubrication

### Fire-Ball

- 241573 Fire-Ball 50:1 Pump Module  
Includes 50:1 Fire-Ball pump #239887, 90 lb. (41 kg) reservoir assembly #241486 and vent valve assembly #241572
- 241486 Reservoir Assembly  
Includes 90 lb. (41 kg) reservoir, gasket and cover.
- 241572 Vent Valve Assembly  
Includes vent valve #115121, air pressure relief valve #115122, vent valve mounting bracket with vent valve air and fluid hose.
- Instruction manual 308955

### Dyna-Star

- 243159 Dyna-Star 5:1 Pump Module  
Includes Dyna-Star pump #224751, 90 lb. (41 kg) reservoir assembly #241486, hydraulic control assembly #243501 and vent valve assembly #243170 fully assembled.
- 241486 Reservoir Assembly  
Includes 90 lb. (41 kg) reservoir, gasket and cover.
- 243501 Hydraulic Control Assembly  
Includes hydraulic manifold with pressure gauge #802072, pressure reducing valve #115774, flow control valve #115773, 24 volt solenoid #115775 and necessary hose, fitting and connectors.
- 243170 Hydraulic Vent Valve Assembly  
Includes vent valve #242063, pressure relief valve #115122 and necessary hose, fittings and connectors.
- Instruction manual 309098.

### GL-1 Injector

Graco Part No.	GL-1 Injector Description	Mounting Hole Spacing: in. (mm)	Manifold Length in. (mm)
114901	One Point	NA (one hole)	2.48 (63.0)
114902	Two Point	NA (one hole)	3.00 (76.0)
114903	Three Point	1.25 (31.7)	4.23 (107.5)
114904	Four Point	2.50 (63.4)	5.47 (139.0)
114905	Five Point	3.75 (95.1)	6.71 (170.5)
114909	Replacement	NA	NA
114910	npt Single - 3/8 npt(m)	NA	NA

*Injector Repair Kit (241234) includes wear items.*

### Lubrication Controller

- 115123 Lubrication Controller, 24 volt  
Instruction manual 308950.

#### Accessories

- 241574 Connector Replacement Kit  
Includes two junction box connectors and six rubber grommets.
- 114488 Air Solenoid Valve  
3/8 npt (f) three-way, 24 volt has manual activation button.
- 115124 Pressure Switch  
Lubricant inlet 1/4 npt(f).

### Level Indicator

- 244023 Level Indicator  
Instruction manual 309200.

### Used Oil Equipment Quick Reference Guide

Description	Part Number	Capacity Gallons (liters)
Oil King™	238866	25 (95)
Oil Ace™	115599	24 (90)
Used Oil Receiver w/drum	239301	16 (60)
Big Hauler™	244055	26 (98)

### Used Oil Evacuation Packages with Air-Operated Diaphragm Pumps

- 222090 1 in (25.4 mm) Double Diaphragm Wall Mount Package
- 224873 3/4 in (19.05 mm) Double Diaphragm Wall Mount Package