

Instructions–Parts List



ALUMINUM

Husky™ 716 Air–operated Diaphragm Pumps

308797P

Used to evacuate and transfer fluids.

100 psi (0.7 MPa, 7 bar) Maximum Fluid Working Pressure

100 psi (0.7 MPa, 7 bar) Maximum Air Input Pressure

Part No. 241407, Series D

with two–direction manifolds

Part No. 241408, Series D

with single–direction manifolds

Patents Pending



Important Safety Instructions

Read all warnings and instructions in this manual.
Save these instructions.

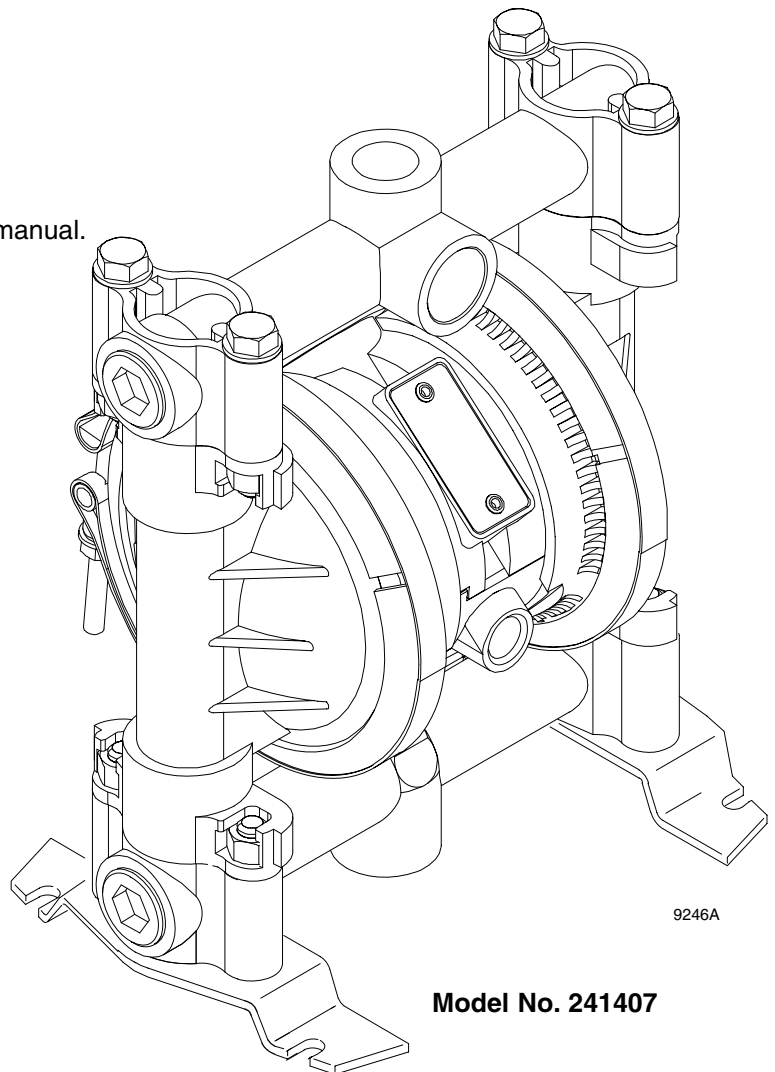

Model No. 241407



II 2 GD c IIC T4



H003

PROVEN QUALITY. LEADING TECHNOLOGY.

Table of Contents

Warnings	2
Installation	4
Operation	10
Maintenance	11
Troubleshooting	12
Service	13
Parts Drawing	18
Parts List	19
Torque Sequence	20
Technical Data	21
241407 and 241408 Repair Kits	21
Dimensions	22
Performance Charts	23
Graco Standard Warranty	26
Graco Information	26

Symbols

Warning Symbol



This symbol alerts you to the possibility of serious injury or death if you do not follow the instructions.

Caution Symbol



This symbol alerts you to the possibility of damage to or destruction of equipment if you do not follow the instructions.

! WARNING



INSTRUCTIONS

EQUIPMENT MISUSE HAZARD

Equipment misuse can cause the equipment to rupture or malfunction and result in serious injury.

- This equipment is for professional use only.
- Read all instruction manuals, tags, and labels before operating the equipment.
- Use the equipment only for its intended purpose. If you are not sure, call your Graco distributor.
- Do not alter or modify this equipment. Use only genuine Graco parts and accessories.
- Check equipment daily. Repair or replace worn or damaged parts immediately.
- Do not exceed the maximum working pressure of the lowest rated component in your system. This equipment has a **100 psi (0.7 MPa, 7 bar) maximum working pressure at 100 psi (0.7 MPa, 7 bar) maximum incoming air pressure.**
- Use fluids and solvents that are compatible with the equipment wetted parts. Refer to the **Technical Data** section of all equipment manuals. Read the fluid and solvent manufacturer's warnings.
- Route hoses away from traffic areas, sharp edges, moving parts, and hot surfaces. Do not expose Graco hoses to temperatures above 82°C (180°F) or below -40°C (-40°F).
- Wear hearing protection when operating this equipment.
- Do not lift pressurized equipment.
- Comply with all applicable local, state, and national fire, electrical, and safety regulations.
- Do not use 1.1.1-trichloroethane, methylene chloride, other halogenated hydrocarbon solvents or fluids containing such solvents in pressurized aluminum equipment. Such use could result in a chemical reaction, with the possibility of explosion.

WARNING



TOXIC FLUID HAZARD

Hazardous fluid or toxic fumes can cause serious injury or death if splashed in the eyes or on the skin, inhaled, or swallowed.

- Know the specific hazards of the fluid you are using.
- Do not lift a pump under pressure. If dropped, the fluid section may rupture. Always follow the **Pressure Relief Procedure** on page 10 before lifting the pump.
- Store hazardous fluid in an approved container. Dispose of hazardous fluid according to all local, state and national guidelines.
- Always wear protective eyewear, gloves, clothing and respirator as recommended by the fluid and solvent manufacturer.
- Pipe and dispose of the exhaust air safely, away from people, animals, and food handling areas. If the diaphragm fails, the fluid is exhausted along with the air. Read **Air Exhaust Ventilation** on page 6.
- **Never** use an acetal pump to pump acids. Take precautions to avoid acid or acid fumes from contacting the pump housing exterior. Stainless steel parts will be damaged by exposure to acid spills and fumes.



FIRE AND EXPLOSION HAZARD

Improper grounding, poor ventilation, open flames or sparks can cause a hazardous condition and result in a fire or explosion and serious injury.

- Ground the equipment. Refer to **Grounding** on page 8.
- If there is any static sparking or you feel an electric shock while using this equipment, **stop pumping immediately**. Do not use the equipment until you identify and correct the problem.
- Provide fresh air ventilation to avoid the buildup of flammable fumes from solvents or the fluid being pumped.
- Pipe and dispose of the exhaust air safely, away from all sources of ignition. If the diaphragm fails, the fluid is exhausted along with the air. Read **Air Exhaust Ventilation** on page 6.
- Keep the work area free of debris, including solvent, rags, and gasoline.
- Electrically disconnect all equipment in the work area.
- Extinguish all open flames or pilot lights in the work area.
- Do not smoke in the work area.
- Do not turn on or off any light switch in the work area while operating or if fumes are present.
- Do not operate a gasoline engine in the work area.

Installation

General Information

- The Typical Installations in Fig. 2 are only guides for selecting and installing system components. Contact your Graco distributor for assistance in planning a system to suit your needs.
- Always use Genuine Graco Parts and Accessories.
- Use a compatible, liquid thread sealant on all male threads. Tighten all connections firmly to avoid air or fluid leaks.

Tightening Threaded Fasteners Before First Use

Before using the pump for the first time, check and retorque all external fasteners. See **Torque Sequence**, page 20. After the first day of operation, retorque the fasteners. Although pump use varies, a general guideline is to retorque fasteners every two months.

Toxic Fluid Hazard



Read **Toxic Fluid Hazard** on page 3.

Use fluids and solvents that are compatible with the equipment wetted parts. Refer to the **Technical Data** section of all equipment manuals. Read the fluid and solvent manufacturer's warnings.

CAUTION

Safe Operating Temperatures

Minimum: 40° F (4° C)

Maximum: 225° F (107° C)

These temperatures are based upon mechanical stress only and may be significantly altered by pumping certain chemicals. Consult engineering guides for chemical compatibilities and temperature limits, or contact your Graco distributor.

Mountings

- These pumps can be used in a variety of installations. Be sure the mounting surface can support the weight of the pump, hoses, and accessories, as well as the stress caused during operation.
- Fig. 2 shows some installation examples. On all installations, mount the pump using screws and nuts.

Pumping High-Density Fluids

High density fluids may prevent the lighter non-metallic check valve balls from seating properly, which reduces pump performance significantly. Stainless steel balls should be used for such applications.

Installation

Air Line

WARNING

A bleed-type master air valve (B) is required in your system to relieve air trapped between this valve and the pump. See Fig. 2. Trapped air can cause the pump to cycle unexpectedly, which could result in serious injury, including splashing in the eyes or on the skin, injury from moving parts, or contamination from hazardous fluids.

CAUTION

The pump exhaust air may contain contaminants. Ventilate to a remote area if the contaminants could affect your fluid supply. Read **Air Exhaust Ventilation** on page 6.

1. Install the air line accessories as shown in Fig. 2. Mount these accessories on the wall or on a bracket. Be sure the air line supplying the accessories is electrically conductive.
 - a. The fluid pressure can be controlled in either of two ways. To control it on the air side, install an air regulator (G). To control it on the fluid side, install a fluid regulator (J) near the pump fluid outlet (see Fig. 2).
 - b. Locate one bleed-type master air valve (B) close to the pump and use it to relieve trapped air. Read the **WARNING** above. Locate the other master air valve (E) upstream from all air line accessories and use it to isolate them during cleaning and repair.
 - c. The air line filter (F) removes harmful dirt and moisture from the compressed air supply.
2. Install an electrically conductive, flexible air hose (C) between the accessories and the 1/4 npt(f) pump air inlet. Use a minimum 1/4 in. (6.3 mm) ID air hose. Screw an air line quick disconnect coupler (D) onto the end of the air hose (C), and screw the mating fitting into the pump air inlet snugly. Do not connect the coupler (D) to the fitting yet.

Fluid Suction Line

- If using a conductive (acetal) pump, use conductive hoses. If using a non-conductive pump, ground the fluid system. Read **Grounding** on page 8. The fluid inlet port is 3/4 in.
- At inlet fluid pressures greater than 15 psi (0.1 MPa, 1 bar), diaphragm life will be shortened.

Fluid Outlet Line

WARNING

A fluid drain valve (H) is required in your system to relieve pressure in the hose if it is plugged. See Fig. 2. The drain valve reduces the risk of serious injury, including splashing in the eyes or on the skin, or contamination from hazardous fluids when relieving pressure. Install the valve close to the pump fluid outlet.

1. Use electrically conductive fluid hoses (K). The pump fluid outlet is 3/4 in. Screw the fluid fitting into the pump outlet snugly. **Do not overtighten.**
2. Install a fluid regulator (J) at the pump fluid outlet to control fluid pressure, if desired (see Fig. 2). See **Air Line**, step 1a, for another method of controlling pressure.
3. Install a fluid drain valve (H) near the fluid outlet. Read the **WARNING** above.

Installation

Fluid Pressure Relief Valve

CAUTION

Some systems may require installation of a pressure relief valve at the pump outlet to prevent overpressurization and rupture of the pump or hose. See Fig. 1.

Thermal expansion of fluid in the outlet line can cause overpressurization. This can occur when using long fluid lines exposed to sunlight or ambient heat, or when pumping from a cool to a warm area (for example, from an underground tank).

Overpressurization can also occur if the Husky pump is being used to feed fluid to a piston pump, and the intake valve of the piston pump does not close, causing fluid to back up in the outlet line.

- 1 Install valve between fluid inlet and outlet ports.
- 2 Connect fluid inlet line here.
- 3 Connect fluid outlet line here.

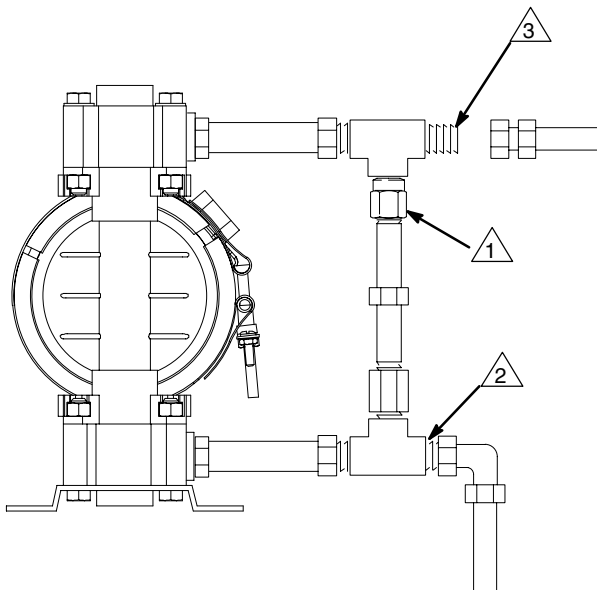

Fig. 1

9073A

Air Exhaust Ventilation



Be sure the system is properly ventilated for your type of installation. You must vent the exhaust to a safe place, away from people, animals, food handling areas, and all sources of ignition when pumping flammable or hazardous fluids.

Diaphragm failure will cause the fluid being pumped to exhaust with the air. Place an appropriate container at the end of the air exhaust line to catch the fluid. See Fig. 2 .

The air exhaust port is 3/8 npt(f). Do not restrict the air exhaust port. Excessive exhaust restriction can cause erratic pump operation.

See **Venting Exhaust Air** in Fig. 2. Exhaust to a remote location as follows:

1. Remove the muffler (W) from the pump air exhaust port.
2. Install an electrically conductive air exhaust hose (X) and connect the muffler to the other end of the hose. The minimum size for the air exhaust hose is 3/8 in. (10 mm) ID. If a hose longer than 15 ft (4.57 m) is required, use a larger diameter hose. Avoid sharp bends or kinks in the hose.
3. Place a container (Z) at the end of the air exhaust line to catch fluid in case a diaphragm ruptures. See Fig. 2.

Installation

ABOVE-GROUND TRANSFER INSTALLATION

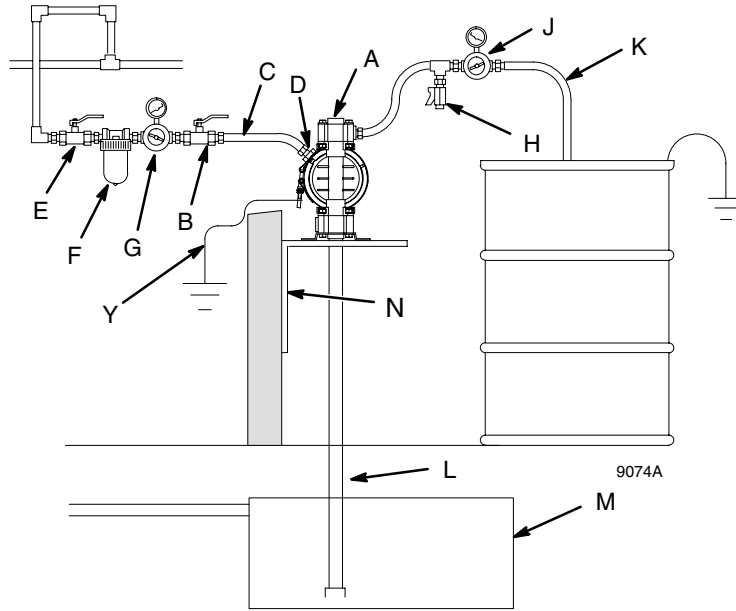

KEY

- A Pump
- B Bleed-type master air valve (required for pump)
- C Electrically conductive air supply line
- D Air line quick disconnect
- E Master air valve (for accessories)
- F Air line filter
- G Pump air regulator
- H Fluid drain valve (required)
- J Fluid regulator (optional)
- K Electrically conductive fluid supply hose
- L Fluid suction line
- M Underground storage tank
- N Wall mounting bracket
- Y Ground wire (required; see page 8 for installation instructions)

55-GALLON BUNG PUMP INSTALLATION

KEY

- A Pump
- C Electrically conductive air supply line
- D Air line quick disconnect
- H Fluid drain valve (required)
- K Electrically conductive fluid supply hose
- L Fluid suction line
- Y Ground wire (required; see page 8 for installation instructions)

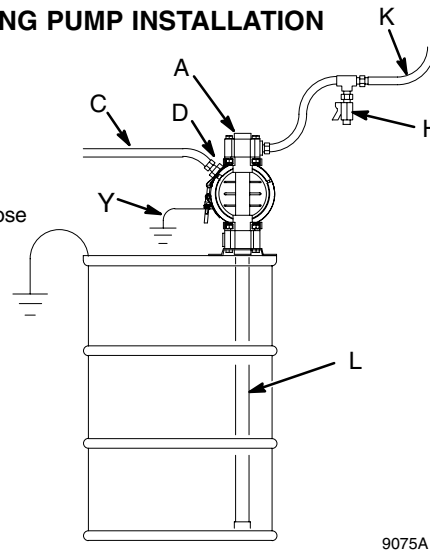

VENTING EXHAUST AIR

KEY

- W Muffler
- X Electrically Conductive Air Exhaust Hose
- Z Container for Remote Air Exhaust

All wetted and non-wetted pump parts must be compatible with the fluid being pumped.

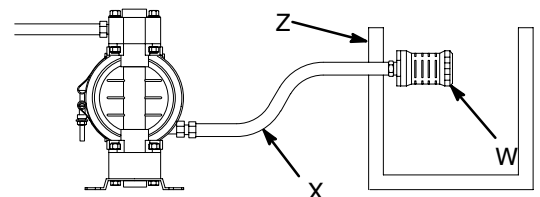

Fig. 2

04054

Installation

Grounding

WARNING



FIRE AND EXPLOSION HAZARD

This pump must be grounded. Before operating the pump, ground the system as explained below. Also read the section **Fire and Explosion Hazard** on page 3.

The metal Husky 716 pumps have a grounding strip connecting the vee clamps (109). Attach a ground wire to the grounding strip with the screw, lockwasher, and nut as shown in the **Grounding Detail** on page 18.

When pumping conductive flammable fluids, **always** ground the entire fluid system by making sure the fluid system has an electrical path to a true earth ground (see Fig. 3).

US Code (NFPA 77 Static Electricity) recommends a conductivity greater than 50×10^{-12} Siemens/meter (mhos/meter) over your operating temperature range to reduce the hazard of fire. Consult your fluid supplier to determine the conductivity or resistivity of your fluid. The resistivity must be less than 2×10^{12} ohm-centimeters.

To reduce the risk of static sparking, ground the pump and all other equipment used or located in the pumping area. Check your local electrical code for detailed grounding instructions for your area and type of equipment.

NOTE: See the **WARNING** above. Fig. 3 shows a recommended method of grounding flammable fluid containers during filling.

Ground all of this equipment:

- **Pump:** The metal pump has a grounding strip in front of the center housing. Connect the non-clamp end of the ground wire to the grounding strip and connect the clamp end of the ground wire to a true earth ground. To order a ground wire and clamp, order Part No. 222011.
- **Air and fluid hoses:** Use only electrically conductive hoses.
- **Air compressor:** Follow the manufacturer's recommendations.
- **Solvent pails used when flushing:** Follow the local code. Use only grounded metal pails, which are conductive. Do not place the pail on a non-conductive surface, such as paper or cardboard, which interrupts the grounding continuity.
- **Fluid supply container:** Follow the local code.

GROUNDING A PUMP

KEY

- A Pump
- H Fluid drain valve (required)
- S Dispense valve
- T Fluid drain line
- Y Fluid section grounding via grounding strip or grounding screw (required for metal and acetal pumps)
- Z Container ground wire (required)

- 1 Hose must be conductive.
- 2 Dispense valve nozzle must be in contact with container.

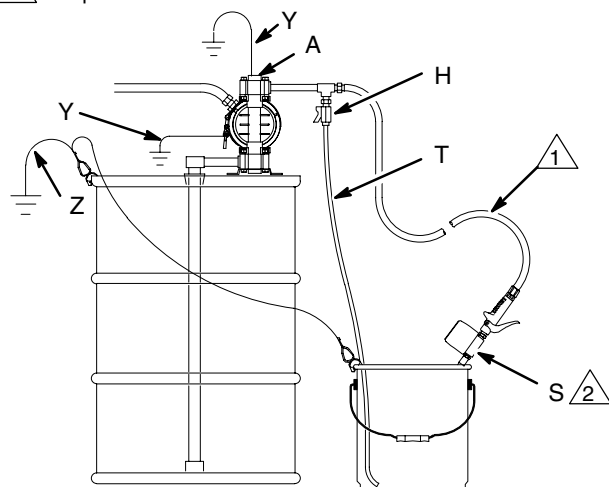



Fig. 3

9079A

Installation

Changing the Orientation of the Fluid Inlet and Outlet Ports

Fig. 4. You can change the orientation of the fluid inlet and outlet ports by repositioning the manifolds.

1.  **Relieve the pressure.** See **Pressure Relief Procedure** on page 10.
2. Remove four manifold bolts (105).
3. Turn manifold to desired position, reinstall bolts, and torque to 80 to 90 in-lb (9 to 10 N•m). See **Torque Sequence**, page 20.

NOTE: Make sure all manifold o-rings are positioned correctly before you fasten the manifold. Manifold o-rings (139) are shown in Fig. 6.

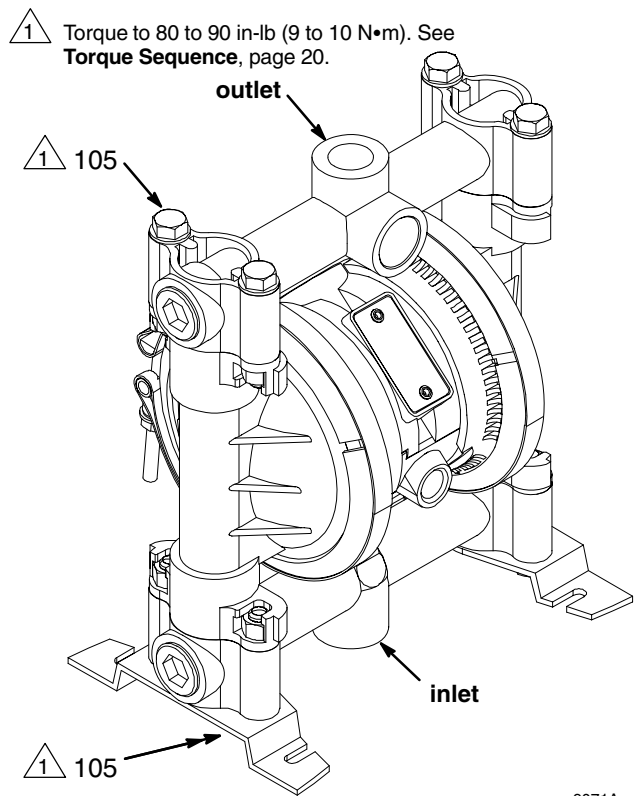

Fig. 4

9071A

Operation

Pressure Relief Procedure

WARNING

PRESSURIZED EQUIPMENT HAZARD

The equipment stays pressurized until pressure is manually relieved. To reduce the risk of serious injury from pressurized fluid, accidental spray, or splashing fluid, follow this procedure whenever you







- Are instructed to relieve pressure
- Stop pumping
- Check, clean, or service any system equipment
- Install or clean fluid nozzles

1. Shut off the air to the pump.
2. Open the dispensing valve, if used.
3. Open the fluid drain valve to relieve all fluid pressure, and have a container ready to catch the drainage.

Flush Pump Before First Use

The pump was tested with lightweight oil which is left in the fluid passages to protect parts. To avoid contaminating your fluid with oil, flush the pump with a compatible solvent before using the equipment. Follow the steps under **Starting and Adjusting Pump**.

Starting and Adjusting Pump

1.   Read **Toxic Fluid Hazard** on page 3.
2.  If lifting the pump, follow the **Pressure Relief Procedure** above.
3.    Be sure the pump is properly grounded. Read **Fire and Explosion Hazard** on page 3.
4. Check all fittings to be sure they are tight. Use a compatible liquid thread sealant on all male threads. Tighten the fluid inlet and outlet fittings snugly. Do not overtighten the fittings into the pump.
5. Place the suction tube (if used) in the fluid to be pumped.

10 308797

NOTE: If the inlet fluid pressure to the pump is more than 25% of the outlet working pressure, the ball check valves will not close fast enough, resulting in inefficient pump operation.

6. Place the end of the fluid hose (K) into an appropriate container.
7. Close the fluid drain valve (H).
8. With the pump air regulator (G) closed, open all bleed-type master air valves (B, E).
9. If the fluid hose has a dispensing device, hold it open while continuing with the following step. Slowly open the air regulator (G) until the pump starts to cycle. Allow the pump to cycle slowly until all air is pushed out of the lines and the pump is primed.

If you are flushing, run the pump long enough to thoroughly clean the pump and hoses. Close the air regulator. Remove the suction tube from the solvent and place it in the fluid to be pumped.

Operation of Remote Piloted Pumps

1. Fig. 2 and Parts Drawings. Follow preceding steps 1 through 8 of **Starting and Adjusting Pump**.
2. Open air regulator (G).

WARNING

The pump may cycle once before the external signal is applied. Injury is possible. If pump cycles, wait until end before proceeding.

3. Pump will operate when air pressure is alternately applied to push type connectors (16).

NOTE: Leaving air pressure applied to the air motor for extended periods when the pump is not running may shorten the diaphragm life. Using a 3-way solenoid valve to automatically relieve the pressure on the air motor when the metering cycle is complete prevents this from occurring.

Pump Shutdown



At the end of the work shift, **relieve the pressure** as described in **Pressure Relief Procedure** at left.

Maintenance

Lubrication

The air valve is lubricated at the factory to operate without additional lubrication. If you want to provide additional lubrication, remove the hose from the pump air inlet and add two drops of machine oil to the air inlet every 500 hours of operation or every month.

CAUTION

Do not over-lubricate the pump. Oil is exhausted through the muffler, which could contaminate your fluid supply or other equipment. Excessive lubrication can also cause the pump to malfunction.

Flushing and Storage

Flush the pump to prevent the fluid you are pumping from drying or freezing in the pump and damaging it. Use a compatible solvent.

Always flush the pump and **relieve the pressure** before you store it for any length of time.



Read **Pressure Relief Procedure** on page 10.

Tightening Threaded Connections

Before each use, check all hoses for wear or damage and replace as necessary. Check to be sure all threaded connections are tight and leak-free.

Check fasteners. Tighten or retorque as necessary. Although pump use varies, a general guideline is to retorque fasteners every two months. See **Torque Sequence**, page 20.

Preventive Maintenance Schedule

Establish a preventive maintenance schedule, based on the pump's service history. This is especially important for prevention of spills or leakage due to diaphragm failure.

Troubleshooting



Read **Pressure Relief Procedure** on page 10, and **relieve the pressure** before you check or service the equipment. Check all possible problems and causes before disassembling the pump.

PROBLEM	CAUSE	SOLUTION
Pump will not cycle, or cycles once and stops.	Air valve is stuck or dirty.	Use filtered air.
Pump cycles at stall or fails to hold pressure at stall.	Leaky check valves or o-rings.	Replace.
	Worn check balls or duckbill valves or guides.	Replace.
	Check ball wedged in guide.	Repair or replace.
	Worn diaphragm shaft seals.	Replace.
Pump operates erratically.	Clogged suction line.	Inspect; clear.
	Sticky or leaking check valve balls.	Clean or replace.
	Diaphragm ruptured.	Replace.
Air bubbles in fluid.	Suction line is loose.	Tighten.
	Diaphragm ruptured.	Replace.
	Loose manifolds or damaged manifold o-rings.	Tighten manifold bolts or nuts; replace o-rings.
	Loose fluid side diaphragm plates.	Tighten.
Fluid in exhaust air.	Diaphragm ruptured.	Replace.
	Loose fluid side diaphragm plates.	Tighten.
	Worn diaphragm shaft seals.	Replace.
Pump exhausts air from clamps (metal pumps).	Loose clamps.	Tighten clamp nuts.
	Air valve o-ring is damaged.	Inspect; replace.
Pump leaks fluid from check valves.	Worn or damaged check valve o-rings.	Inspect; replace.

Service

Air Valve

NOTE: Air Valve Repair Kit 241657 is available. Parts included in the kit are marked with a dagger (†) in Fig. 5 and in the Parts Drawings and Lists. A tube of general purpose grease 111920 is supplied in the kit. Service the air valve as follows. See Fig. 5.



1. **Relieve the pressure.** See **Pressure Relief Procedure** on page 10.

2. Remove the cover (10) and the o-ring (4).
3. Remove the carriage plungers (7), carriages (8), carriage pins (9), and valve plate (14) from the center housing (11).
4. Clean all the parts, and inspect them for wear or damage.

NOTE: If you are installing the new Air Valve Repair Kit 241657, use all the parts in the kit.

5. Grease the lapped surface of the valve plate (14), and install the valve plate with the lapped surface facing up.
6. Grease the bores of the center housing (11), install the u-cup packings (2) on the carriage plungers (7), and slide the carriage plungers into the carriage plunger bores. See the following important installation notes:

NOTES:

- When you install each u-cup packing (2) on each carriage plunger (7), make sure the lips of the u-cup packing face toward the **clip end** (the smaller end) of the carriage plunger.
 - When you slide the carriage plungers (7) into the bores, slide them in with the clip ends (the smaller ends) facing toward the center of the center housing (11).
7. Grease the carriage pins (9), and slide the carriage pins into the carriage pin bores.
 8. Install the carriages (8). Make sure the carriages engage the clip ends of the carriage plungers (7) and carriage pins (9).
 9. Grease the o-ring (4), and seat it in the groove around the cover opening of the center housing (11).
 10. Screw the cover (10) into the center housing, and torque the cover to 80 to 100 in-lb (9.0 to 13.6 N-m).

NOTE: Center housing (11) is shown separated from the air covers, but it is not necessary to remove the air covers for this service. Leave the center housing and air covers assembled for this service.

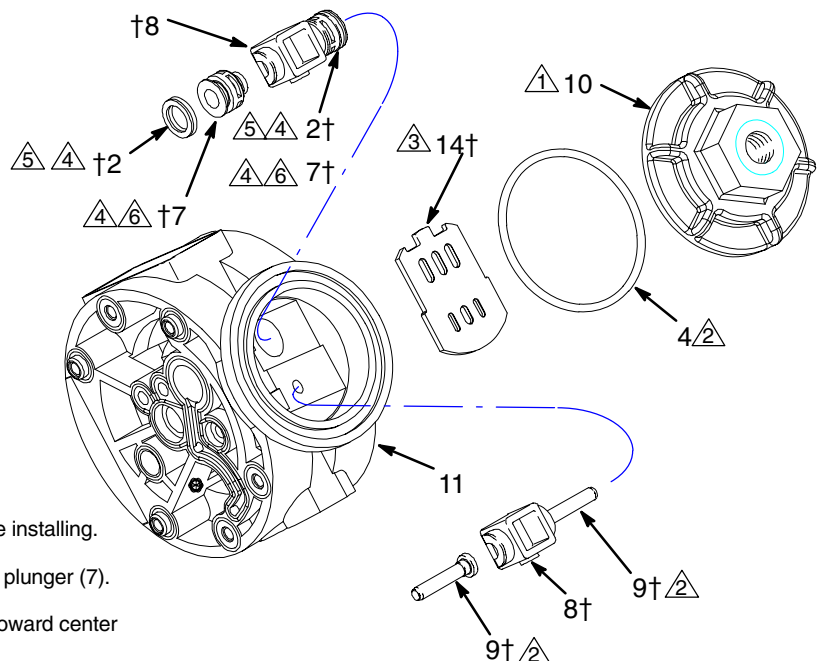

† Included in Air Valve Repair Kit 241657

- 1 Torque to 80 to 100 in-lb (9.0 to 13.6 N-m).
- 2 Apply grease.
- 3 Apply grease to lapped face.
- 4 Apply grease to bores of center housing (11) before installing.
- 5 Seal lips face clip end (the smaller end) of carriage plunger (7).
- 6 Install with the clip ends (the smaller ends) facing toward center of center housing (11).

Fig. 5

9069A

Service

Ball Check Valves

NOTE: Fluid Section Repair Kit D05977 is available. See page 21 to order the correct kit for your pump. Parts included in the kit are marked with a double dagger (‡) in Fig. 6 and in the Parts Drawings and Lists. General purpose grease 111920 and Adhesive 113500 are supplied in the kit.



1. **Relieve the pressure.** See **Pressure Relief Procedure** on page 10.

2. Remove the top and bottom manifolds (102, 103).

3. Remove all parts shown with a dagger (†) Fig. 6.
4. Clean all parts, and replace worn or damaged parts.
5. Reassemble the pump.

NOTE: Torque the manifold bolts (105) to 80 to 90 in-lb (9 to 10 N•m). See **Torque Sequence**, page 20.

Service

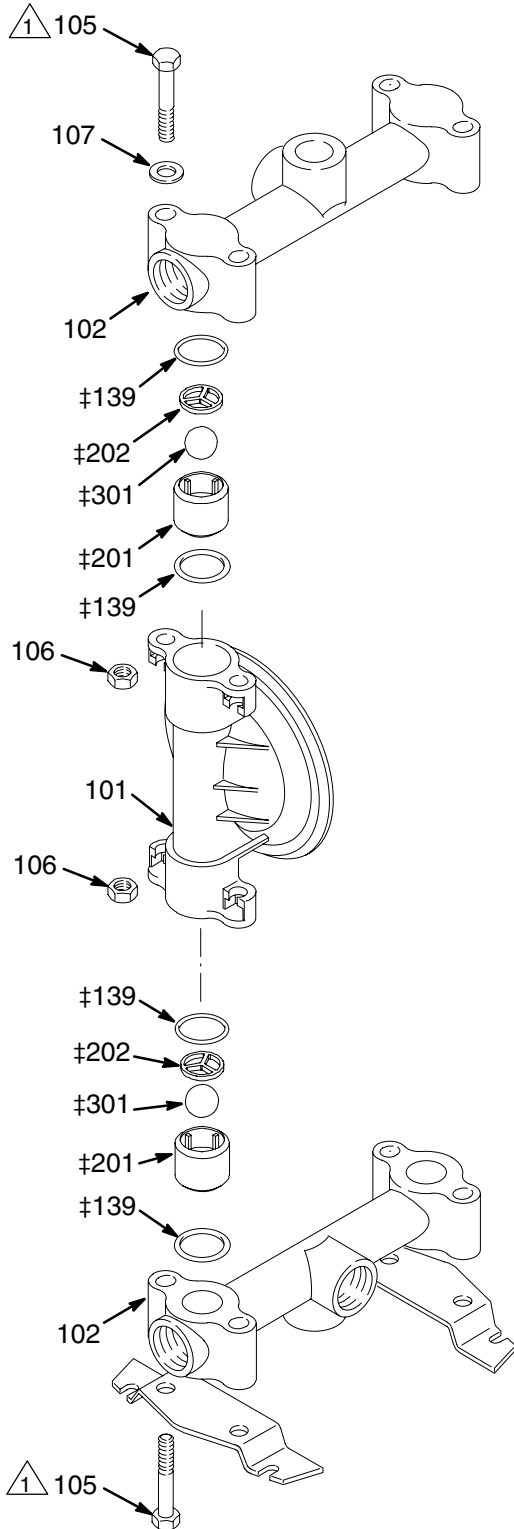

 Torque to 80 to 90 in-lb (9 to 10 N•m). See **Torque Sequence**, page 20.

9081A

Fig. 6

Service

Diaphragms

NOTE: Fluid Section Repair Kit D05977 is available. Parts included in the kit are marked with a double dagger (‡) in Fig. 7 and in the Parts Drawings and Lists. General purpose grease 111920 and Adhesive 113500 are supplied in the kit. Service the diaphragms as follows. See Fig. 7.

Disassembly



1. **Relieve the pressure.** See **Pressure Relief Procedure** on page 10.

2. Remove the manifolds (102) and fluid covers (101).

NOTE: Make sure all the check valve parts stay in place. See Fig. 6 on page 15.

3. Remove the grounding strip from the vee clamps (109), and remove the vee clamps.
4. Remove one of the fluid-side diaphragm plates (133) (whichever one comes loose first when you use a wrench on the hex of each), and pull the diaphragm shaft out of the center housing (11).
5. Use a wrench on the flats of the diaphragm shaft (15) to remove the other fluid-side diaphragm plate (133) from the diaphragm shaft.
6. Remove the screws (141) and air covers (136), and remove all old gasket (12) material from the ends of the center housing (11) and the surfaces of the air covers.
7. Remove the diaphragm shaft u-cups (16) and pilot pin o-rings (1).
8. Inspect all parts for wear or damage, and replace as necessary.

Reassembly

1. Insert a diaphragm shaft u-cup (16) and a pilot pin o-ring (1) into the end of the diaphragm shaft bore of the center housing (11).

NOTE: Make sure the lips of the u-cup face **out** of the center housing.

2. Line up the holes in the gasket (12) with the holes in the end of the center housing (11), and use six screws (141) to fasten an air cover (136) to the end of the center housing (11). Torque the screws to 35 to 45 in-lb (4.0 to 5.1 N•m).

3. Position the exhaust cover (13) and o-ring (4) on the center housing (11).
4. Repeat steps 1 and 2 for the other end of the center housing and the remaining air cover.
5. Apply medium-strength (blue) Loctite or equivalent to the threads of the screws (140). Install on one end of the diaphragm shaft (15) the following parts (see proper order in Fig. 7): air-side diaphragm plate (6), diaphragm (401), fluid-side diaphragm plate (133), o-ring (115), and screw (140).
NOTE: The words "AIR SIDE" on the diaphragm (401) and the flat side of the air-side diaphragm plate (6) must face toward the diaphragm shaft (15).
6. Put grease on the diaphragm shaft (15), and carefully (do not damage the shaft u-cups) run the diaphragm shaft (15) through the center housing (11) bore.
7. Repeat step 5 for the other end of the diaphragm shaft (15), and torque the diaphragm shaft screws (140) to 80 to 90 in-lb (9 to 10 N•m) at 100 rpm maximum.
8. Install the muffler (3).

When you install the vee clamps in step 10, orient the center housing (11) so the air inlet is approximately 45° above horizontal and the muffler (3) is approximately horizontal.

9. Apply thin, even film of grease to inside of vee clamp (109).
10. Position the fluid covers (101), install the vee clamps (109) around the fluid and air covers, install the grounding strip on the vee clamps, and torque the vee clamp nuts to 80 to 90 in-lb (9 to 10 N•m). See **Torque Sequence**, page 20.
11. Make sure all the check valve parts are in place. See Fig. 6 on page 15.
12. Install the manifolds (102), and torque the manifold bolts (105) to 80 to 90 in-lb (9 to 10 N•m). See **Torque Sequence**, page 20.

Service

Diaphragms

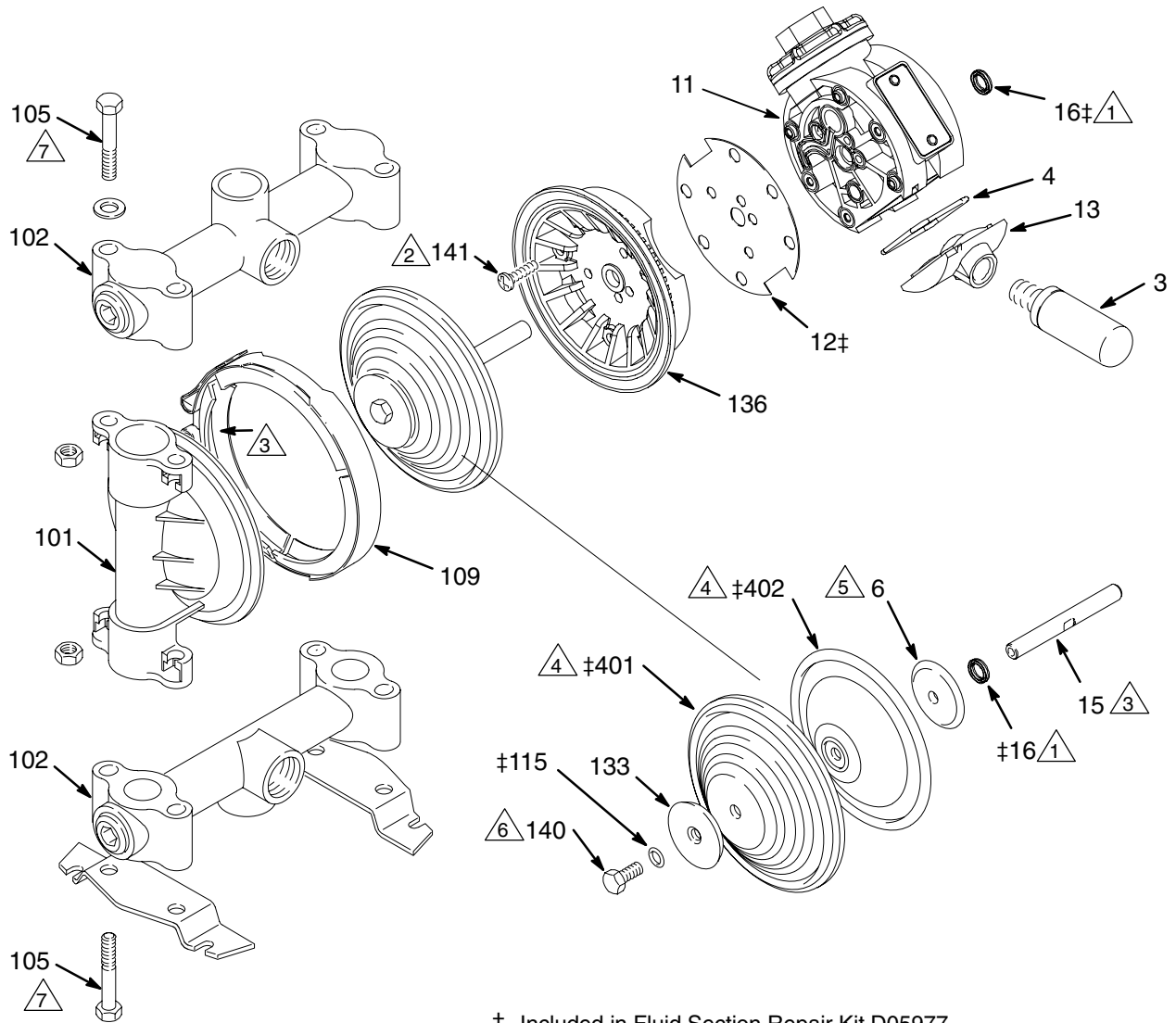

‡ Included in Fluid Section Repair Kit D05977

- ▲ 1 Install with lips facing out of center housing (11).
- ▲ 2 Torque to 35 to 45 in-lb (4.0 to 5.1 N•m).
- ▲ 3 Apply grease.
- ▲ 4 The words "AIR SIDE" on diaphragm and backup diaphragm must face toward diaphragm shaft (15).
- ▲ 5 Flat side of the air-side diaphragm plate must face toward diaphragm shaft (15).
- ▲ 6 Apply medium-strength (blue) Loctite® or equivalent to threads, and torque to 80 to 90 in-lb (9 to 10 N•m) at 100 rpm maximum.
- ▲ 7 Torque to 80 to 90 in-lb (9 to 10 N•m). See **Torque Sequence**, page 20.

Fig. 7

9072A

241407 and 241408 Parts List

Fluid Section Parts List

Ref. No.	Part No.	Description	Qty
101	185622	COVER, fluid; aluminum	2
102	185624	MANIFOLD; aluminum; NPT	2
103	189220	LABEL, warning	1
105	112912	SCREW; 3/8-16; 2.25 in. (57.2 mm)	8
106	112913	NUT, hex; 3/8-16; sst	8
107	112914	WASHER, flat; 3/8 in.; sst	4
108	186207	BASE, feet	2
109	189540	CLAMP, vee	2
110	112499	NUT, clamp; 1/4-28	2
111	191079	STRIP, grounding	1
112*	102726	PLUG, steel; NPT	2
115‡	110004	O-RING; PTFE	2
117	186205	LABEL, warning	1
121	102790	SCREW; 10-24; 0.31 in. (8 mm)	1
122	100718	LOCKWASHER; #10	1
123	100179	NUT, hex; 10-24	1
125*	100896	BUSHING, 3/4 X 1/2 npt	4
133	191837	PLATE, diaphragm, fluid side; sst	2
134	290045	PLATE, designation	1
136	194246	COVER air	2
139‡	110636	O-RING; PTFE	8
140	113747	SCREW, flange; hex head	2
141	114882	SCREW, machine, torx	12
142	111183	RIVET (for plate 134)	2

Air Motor Parts List

Ref. No.	Part No.	Description	Qty
1‡	114866	PACKING, o-ring	2
2†	108808	PACKING, u-cup	2
3	112933	MUFFLER	1
4†	162942	PACKING, o-ring	2

6	195025	PLATE, diaphragm, air side	2
7†	15Y825	PLUNGER, carriage	2
8†	192595	CARRIAGE	2
9†	192596	PIN, carriage	2
10	192597	COVER, valve chamber	1
11	192602	HOUSING, center	1
12‡	192765	GASKET	2
13	194247	COVER, exhaust	1
14†	194269	PLATE, valve	1
15	192601	SHAFT, diaphragm	1

Guide Parts List

Ref. No.	Part No.	Description	Qty
201‡	186776	GUIDE, polypropylene	4
202‡	186777	STOP, polypropylene	4

Ball Parts List

Ref. No.	Part No.	Description	Qty
301‡	108944	BALL, buna-N	4

Diaphragm Parts List

Ref. No.	Part No.	Description	Qty
16‡	108808	PACKING, u-cup	2
401‡	190148	DIAPHRAGM, buna-N	2

* Item 112, 102726 used on 241408, item 125, 100896 used on 241407

† Included in Air Valve Repair Kit 241657

‡ Included in Fluid Section Repair Kit D05977

Torque Sequence

Always follow torque sequence when instructed to torque fasteners.

1. Left/Right Fluid Covers
Torque bolts to 80–90 in-lb (9–10 N•m).

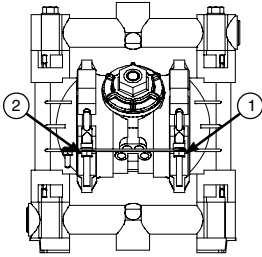

FRONT VIEW

3. Outlet Manifold
Torque bolts to 80–90 in-lb (9–10 N•m).

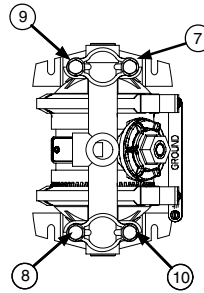

TOP VIEW

2. Inlet Manifold
Torque bolts to 80–90 in-lb (9–10 N•m).

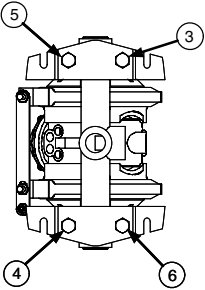

BOTTOM VIEW

Technical Data

Maximum fluid working pressure	100 psi (0.7 MPa, 7 bar)
Air pressure operating range	30 to 100 psi (0.2 to 0.7 MPa, 2.1 to 7 bar)
Maximum air consumption	28 scfm (0.672 cubic meters/min.)
Maximum free flow delivery	16 gpm (61 l/min)
Maximum pump speed	400 cpm
Gallons (Liters) per cycle	0.04(0.15)
Maximum suction lift (water w/buna balls)	15 ft (4.5 m) dry, 25 ft (7.6 m) wet
Maximum size pumpable solids	3/32 in. (2.5 mm)
Sound power level (measured per ISO standard 9614-2)	
At 70 psig (0.48 MPa, 4.8 bar) at 50 cycles per minute	77 dBa
At 100 psig (0.7 MPa, 7 bar) at maximum cycles per minute	95 dBa
Sound pressure level (measured 1 meter from pump)	
At 70 psig (0.48 MPa, 4.8 bar) at 50 cycles per minute	67 dBa
At 100 psig (0.7 MPa, 7 bar) at maximum cycles per minute	85 dBa
Air inlet size	1/4 npt(f)
Air exhaust port size	3/8 npt(f)
Fluid inlet size	3/4 npt(f)
Fluid outlet size	3/4 npt(f)
Wetted parts (in addition to ball, seat, and diaphragm materials, which vary by pump)	
Aluminum pumps	aluminum, stainless steel, PTFE, zinc-plated steel
Stainless steel pumps	316 stainless steel, PTFE
Non-wetted external parts	polypropylene, stainless steel, polyester (labels), nickel-plated brass, epoxy-coated steel (feet)
Weight (approximate)	
Aluminum pumps	8.5 lb (3.9 kg)
Stainless steel pumps	18 lb (8.2 kg)

Santoprene® is a registered trademark of the Monsanto Company.

Loctite® is a registered trademark of the Loctite Corporation.

241407 and 241408 Repair Kits

NOTE: Order Repair Kits separately.

To order the Air Valve Repair Kit, order **Part No. 241657**.

To order the Fluid Section Repair Kit, order **Part No. D05977**.

Husky 716 Dimensions

FRONT VIEW

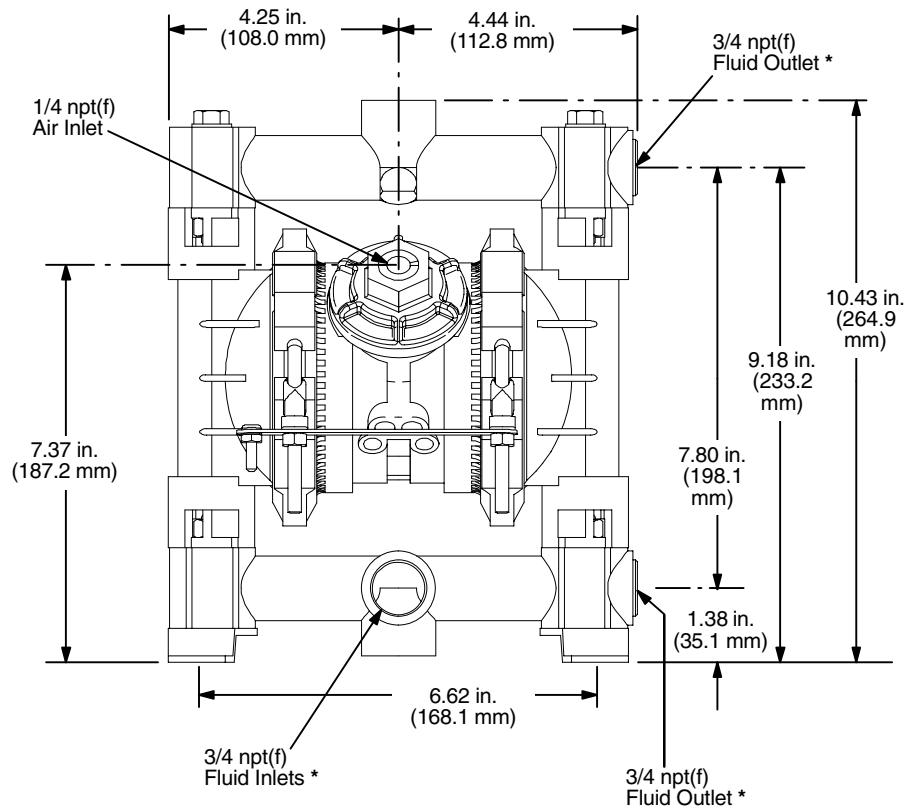

SIDE VIEW

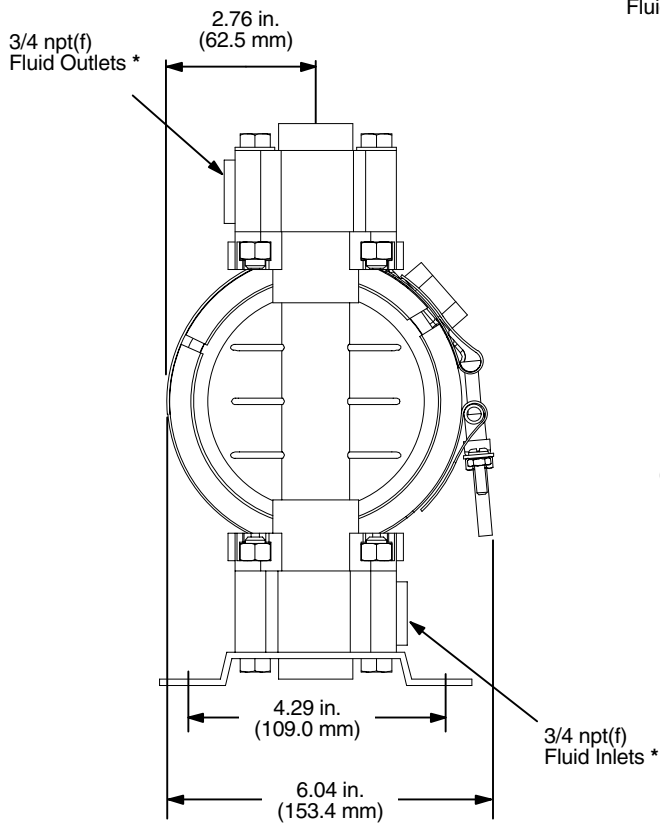

PUMP MOUNTING HOLE PATTERN

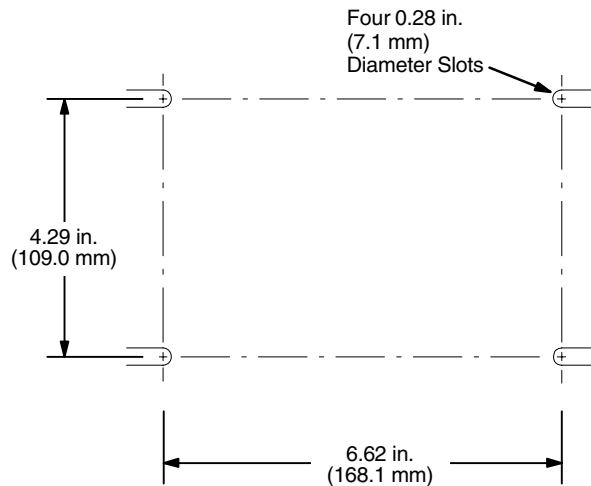

9078A

Performance Charts

Fluid Outlet Pressure

Test Conditions: Pump tested in water with inlet submerged.

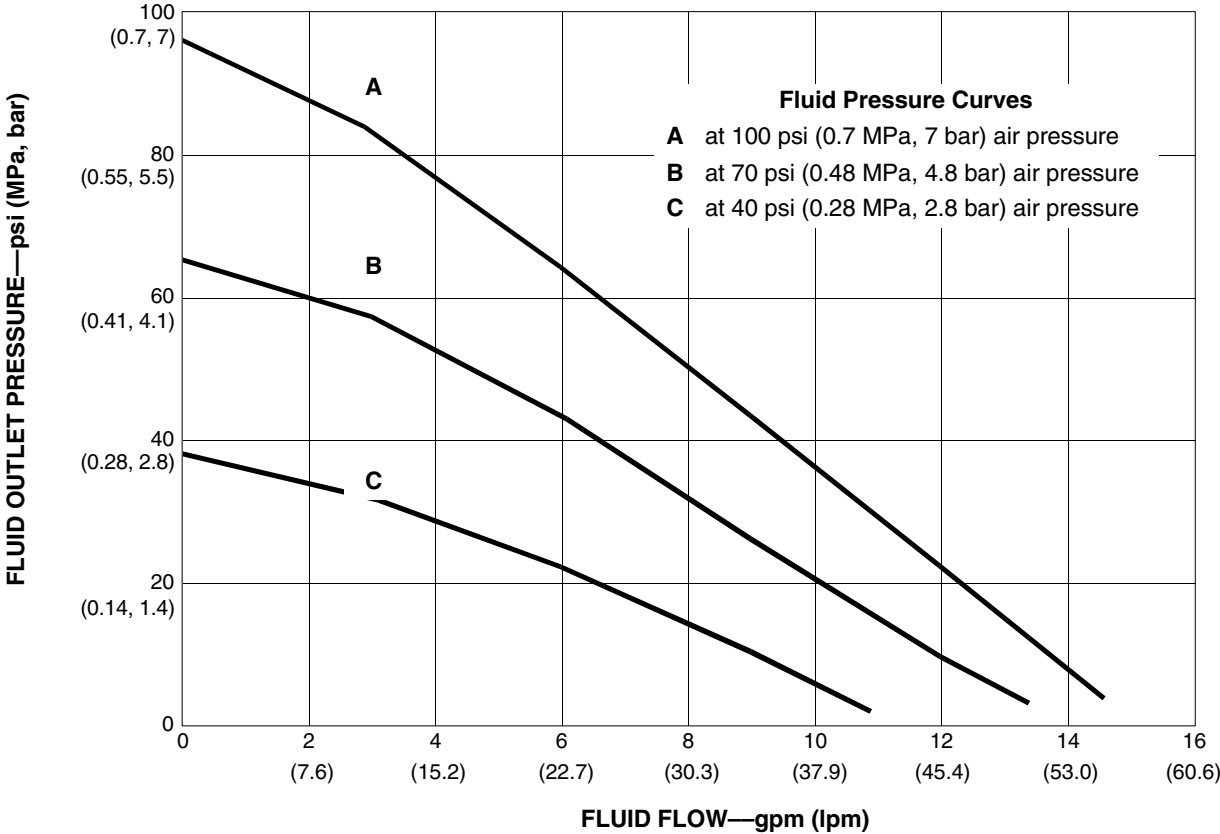

To find Fluid Outlet Pressure (psi/MPa/bar) at a specific fluid flow (gpm/lpm) and operating air pressure (psi/MPa/bar):

1. Locate fluid flow rate along bottom of chart.
2. Follow vertical line up to intersection with selected fluid outlet pressure curve.
3. Follow left to scale to read fluid outlet pressure.

Performance Charts

Air Consumption

Test Conditions: Pump tested in water with inlet submerged.

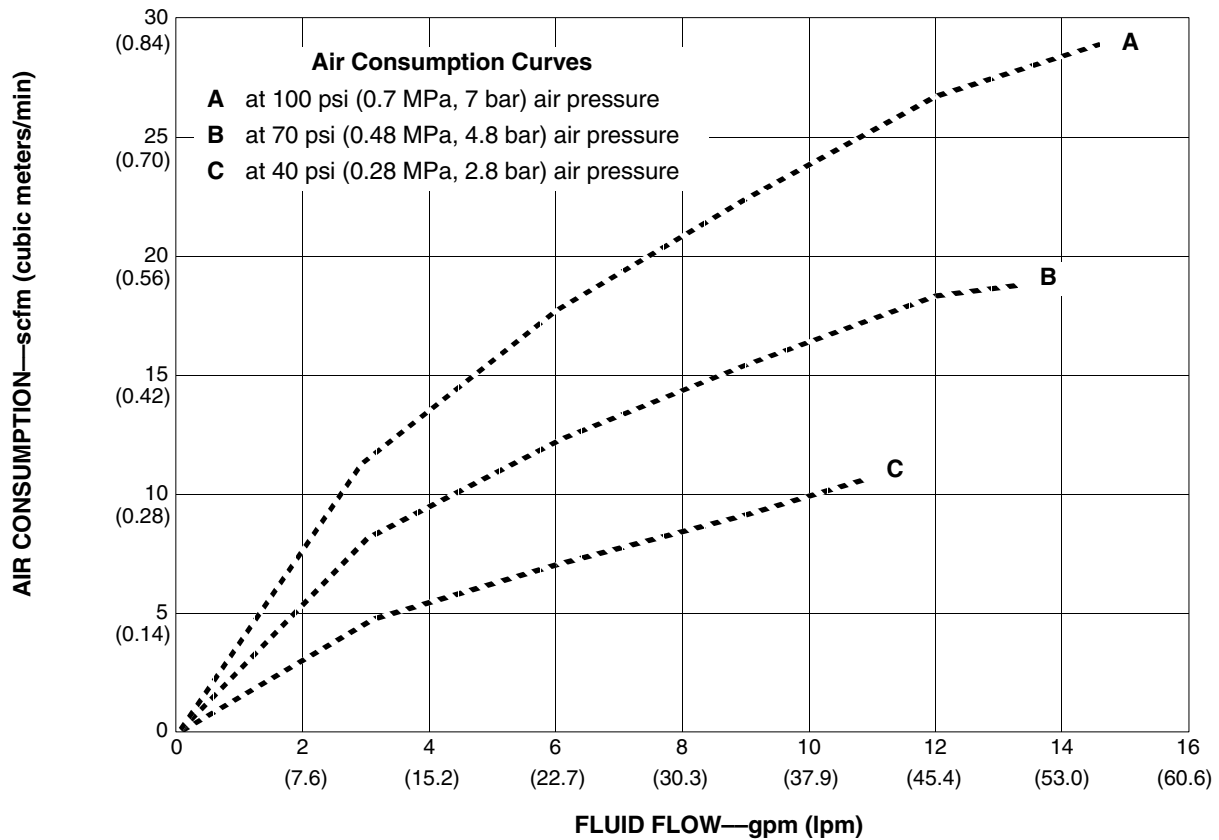

To find Pump Air Consumption (scfm or m³/min) at a specific fluid flow (gpm/lpm) and air pressure (psi/MPa/bar):

1. Locate fluid flow rate along bottom of chart.
2. Read vertical line up to intersection with selected air consumption curve.
3. Follow left to scale to read air consumption.