

Instructions–Parts List



ACETAL®

Husky™ 515 Air–Operated Dual Inlet Diaphragm Pump

309204G

Used to evacuate and transfer fluids.

100 psi (0.7 MPa, 7 bar) Maximum Fluid Working Pressure

100 psi (0.7 MPa, 7 bar) Maximum Air Input Pressure

Part No. 243669, Series B



Important Safety Instructions

Read all warnings and instructions in the manual.
Save these instructions.

Patents Pending

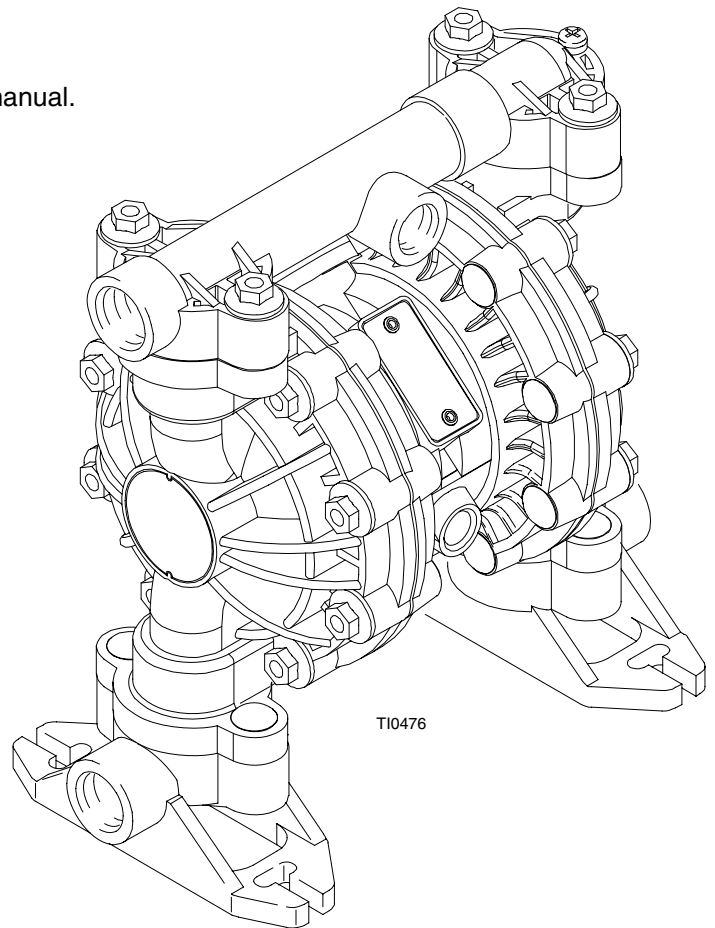

II 2 GD c IIC T4



H003

PROVEN QUALITY. LEADING TECHNOLOGY.

Table of Contents

Safety Warnings	2
Installation	4
Operation	10
Maintenance	11
Troubleshooting	12
Service	13
Parts	18
Torque Sequence	20
Technical Data	21
Dimensions	22
Husky 515 Performance Charts	23
Graco Standard Warranty	26
Graco Information	26

Symbols

Warning Symbol



This symbol alerts you to the possibility of serious injury or death if you do not follow the instructions.

Caution Symbol



This symbol alerts you to the possibility of damage to or destruction of equipment if you do not follow the instructions.

! WARNING



INSTRUCTIONS

EQUIPMENT MISUSE HAZARD

Equipment misuse can cause the equipment to rupture or malfunction and result in serious injury.

- This equipment is for professional use only.
- Read all instruction manuals, tags, and labels before operating the equipment.
- Use the equipment only for its intended purpose. If you are not sure, call your Graco distributor.
- Do not alter or modify this equipment. Use only genuine Graco parts and accessories.
- Check equipment daily. Repair or replace worn or damaged parts immediately.
- Do not exceed the maximum working pressure of the lowest rated component in your system. This equipment has a **100 psi (0.7 MPa, 7 bar) maximum working pressure at 100 psi (0.7 MPa, 7 bar) maximum incoming air pressure.**
- Use fluids and solvents that are compatible with the equipment wetted parts. Refer to the **Technical Data** section of all equipment manuals. Read the fluid and solvent manufacturer's warnings.
- Route hoses away from traffic areas, sharp edges, moving parts, and hot surfaces. Do not expose Graco hoses to temperatures above 82°C (180°F) or below -40°C (-40°F).
- Wear hearing protection when operating this equipment.
- Do not lift pressurized equipment.
- Comply with all applicable local, state, and national fire, electrical, and safety regulations.
- Do not use 1.1.1-trichloroethane, methylene chloride, other halogenated hydrocarbon solvents or fluids containing such solvents in pressurized aluminum equipment. Such use could result in a chemical reaction, with the possibility of explosion.

WARNING



TOXIC FLUID HAZARD

Hazardous fluid or toxic fumes can cause serious injury or death if splashed in the eyes or on the skin, inhaled, or swallowed.

- Know the specific hazards of the fluid you are using.
- Do not lift a pump under pressure. If dropped, the fluid section may rupture. Always follow the **Pressure Relief Procedure** on page 10 before lifting the pump.
- Store hazardous fluid in an approved container. Dispose of hazardous fluid according to all local, state and national guidelines.
- Always wear protective eyewear, gloves, clothing and respirator as recommended by the fluid and solvent manufacturer.
- Pipe and dispose of the exhaust air safely, away from people, animals, and food handling areas. If the diaphragm fails, the fluid is exhausted along with the air. Read **Air Exhaust Ventilation** on page 6.
- **Never** use an acetal pump to pump acids. Take precautions to avoid acid or acid fumes from contacting the pump housing exterior. Stainless steel parts will be damaged by exposure to acid spills and fumes.



FIRE AND EXPLOSION HAZARD

Improper grounding, poor ventilation, open flames or sparks can cause a hazardous condition and result in a fire or explosion and serious injury.

- Ground the equipment. Refer to **Grounding** on page 8.
- **Never** use a polypropylene or PVDF pump with non-conductive flammable fluids as specified by your local fire protection code. Refer to **Grounding** on page 8 for additional information. Consult your fluid supplier to determine the conductivity or resistivity of your fluid.
- If there is any static sparking or you feel an electric shock while using this equipment, **stop pumping immediately**. Do not use the equipment until you identify and correct the problem.
- Provide fresh air ventilation to avoid the buildup of flammable fumes from solvents or the fluid being pumped.
- Pipe and dispose of the exhaust air safely, away from all sources of ignition. If the diaphragm fails, the fluid is exhausted along with the air. Read **Air Exhaust Ventilation** on page 6.
- Keep the work area free of debris, including solvent, rags, and gasoline.
- Electrically disconnect all equipment in the work area.
- Extinguish all open flames or pilot lights in the work area.
- Do not smoke in the work area.
- Do not turn on or off any light switch in the work area while operating or if fumes are present.
- Do not operate a gasoline engine in the work area.

Installation

General Information

- The Typical Installations in Fig. 2 are only guides for selecting and installing system components. Contact your Graco distributor for assistance in planning a system to suit your needs.
- Always use Genuine Graco Parts and Accessories.
- Use a compatible, liquid thread sealant on all male threads. Tighten all connections firmly to avoid air or fluid leaks.

Tightening Threaded Fasteners Before First Use

Before using the pump for the first time, check and retorque all external fasteners. See **Torque Sequence**, page 20. After the first day of operation, retorque the fasteners. Although pump use varies, a general guideline is to retorque fasteners every two months.

Toxic Fluid Hazard



Read **Toxic Fluid Hazard** on page 3.

Use fluids and solvents that are compatible with the equipment wetted parts. Refer to the **Technical Data** section of all equipment manuals. Read the fluid and solvent manufacturer's warnings.

CAUTION

Safe Operating Temperatures

Minimum: 40° F (4° C)

Maximum: 180° F (82° C)

These temperatures are based upon mechanical stress only and may be significantly altered by pumping certain chemicals. Consult engineering guides for chemical compatibilities and temperature limits, or contact your Graco distributor.

Mountings

- Be sure the mounting surface can support the weight of the pump, hoses, and accessories, as well as the stress caused during operation.
- Fig. 2 shows a typical installation. Mount the pump using screws and nuts.

Installation

Air Line

WARNING

A bleed-type master air valve (B) is required in your system to relieve air trapped between this valve and the pump. See Fig. 2. Trapped air can cause the pump to cycle unexpectedly, which could result in serious injury, including splashing in the eyes or on the skin, injury from moving parts, or contamination from hazardous fluids.

CAUTION

The pump exhaust air may contain contaminants. Ventilate to a remote area if the contaminants could affect your fluid supply. Read **Air Exhaust Ventilation** on page 6.

1. Install the air line accessories as shown in Fig. 2. Mount these accessories on the wall or on a bracket. Be sure the air line supplying the accessories is electrically conductive.
 - a. The fluid pressure can be controlled by installing an air regulator (G).
 - b. Locate one bleed-type master air valve (B) close to the pump and use it to relieve trapped air. Read the **WARNING** above. Locate the other master air valves upstream from all air line accessories and use it to isolate them during cleaning and repair.
 - c. The air line filter (F) removes harmful dirt and moisture from the compressed air supply.
2. Install an electrically conductive, flexible air hose (C) between the accessories and the 1/4 npt(f) pump air inlet. Use a minimum 1/4" (6.3 mm) ID air hose. Screw an air line quick disconnect coupler (D) onto the end of the air hose (C), and screw the mating fitting into the pump air inlet snugly. Do not connect the coupler (D) to the fitting yet.

Fluid Suction Line

- If using a conductive (acetal) pump, use conductive hoses. If using a non-conductive pump, ground the fluid system. Read **Grounding** on page 8. The fluid inlet ports are 3/4 in.
- At inlet fluid pressures greater than 15 psi (0.1 MPa, 1 bar), diaphragm life will be shortened.

Fluid Outlet Line

WARNING

A fluid drain valve (H) is required in your system to relieve pressure in the hose if it is plugged. See Fig. 2. The drain valve reduces the risk of serious injury, including splashing in the eyes or on the skin, or contamination from hazardous fluids when relieving pressure. Install the valve close to the pump fluid outlet.

1. Use electrically conductive fluid hoses (K). The pump fluid outlet is 1/2 in. or 3/4 in. Screw the fluid fitting into the pump outlet snugly. **Do not overtighten.**
2. The fluid pressure can be controlled by installing an air regulator (G).
3. Install a fluid drain valve (H) near the fluid outlet. Read the **WARNING** above.

Installation

Fluid Pressure Relief Valve

CAUTION

Some systems may require installation of a pressure relief valve at the pump outlet to prevent overpressurization and rupture of the pump or hose. See Fig. 1.

Thermal expansion of fluid in the outlet line can cause overpressurization. This can occur when using long fluid lines exposed to sunlight or ambient heat, or when pumping from a cool to a warm area (for example, from an underground tank).

Overpressurization can also occur if the Husky pump is being used to feed fluid to a piston pump, and the intake valve of the piston pump does not close, causing fluid to back up in the outlet line.

- 1 Install valve between fluid inlet and outlet ports.
- 2 Connect fluid inlet line here.
- 3 Connect fluid outlet line here.

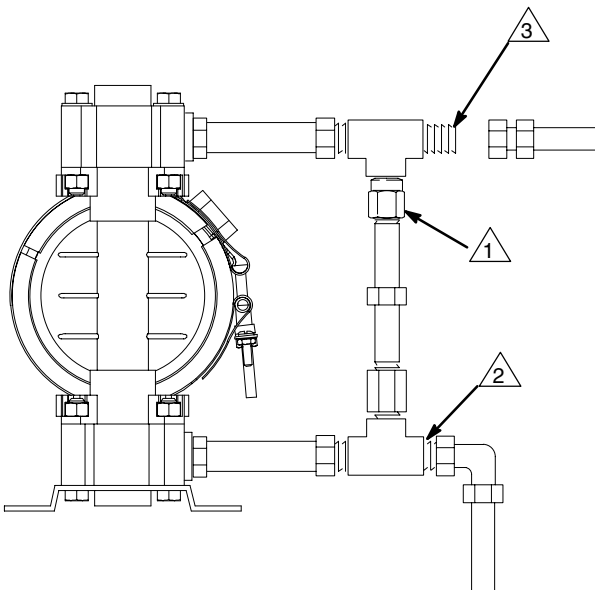

Fig. 1

9073A

Air Exhaust Ventilation



Read **Toxic Fluid Hazard** on page 3.



Read **Fire and Explosion Hazard** on page 3.

Be sure the system is properly ventilated for your type of installation. You must vent the exhaust to a safe place, away from people, animals, food handling areas, and all sources of ignition when pumping flammable or hazardous fluids.

Diaphragm failure will cause the fluid being pumped to exhaust with the air. Place an appropriate container at the end of the air exhaust line to catch the fluid. See Fig. 2 .

The air exhaust port is 3/8 npt(f). Do not restrict the air exhaust port. Excessive exhaust restriction can cause erratic pump operation.

See **Venting Exhaust Air** in Fig. 2. Exhaust to a remote location as follows:

1. Remove the muffler (W) from the pump air exhaust port.
2. Install an electrically conductive air exhaust hose (X) and connect the muffler to the other end of the hose. The minimum size for the air exhaust hose is 3/8 in. (10 mm) ID. If a hose longer than 15 ft (4.57 m) is required, use a larger diameter hose. Avoid sharp bends or kinks in the hose.
3. Place a container (Z) at the end of the air exhaust line to catch fluid in case a diaphragm ruptures. See Fig. 2.

Installation

TYPICAL PUMP INSTALLATION

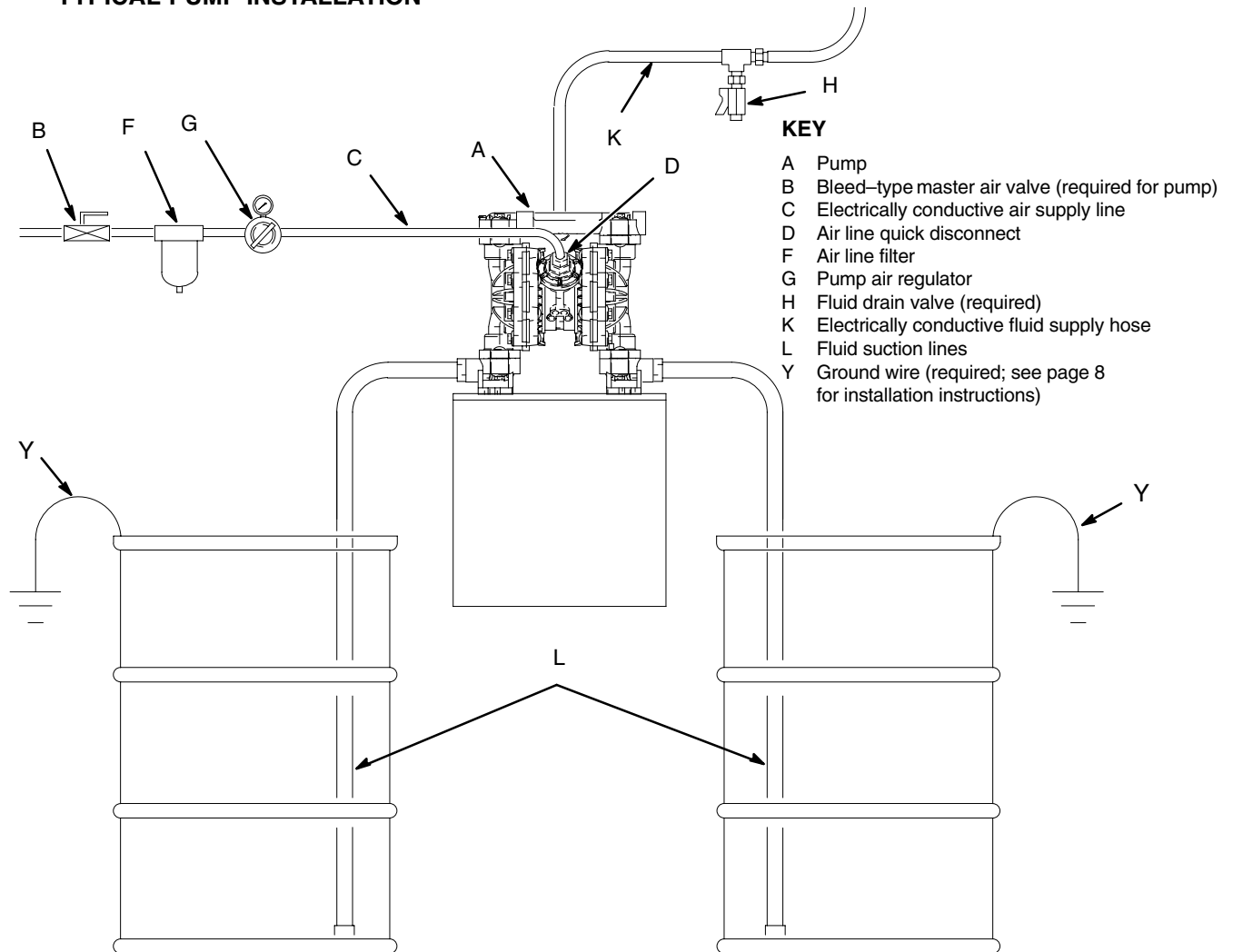

T10477B

VENTING EXHAUST AIR

KEY

- W Muffler
- X Electrically Conductive Air Exhaust Hose
- Z Container for Remote Air Exhaust

All wetted and non-wetted pump parts must be compatible with the fluid being pumped.

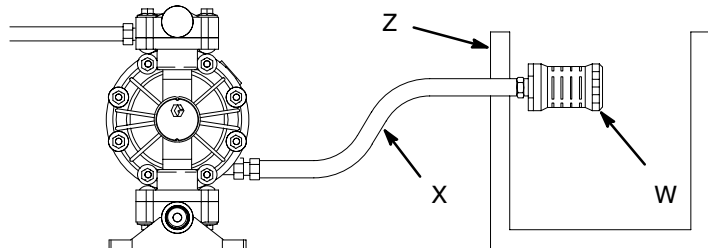

T10478

Fig. 2

Installation

Grounding

WARNING



FIRE AND EXPLOSION HAZARD

This pump must be grounded. Before operating the pump, ground the system as explained below. Also read the section **Fire and Explosion Hazard** on page 3.

The acetal Husky 515 pump contains stainless steel fibers, which makes the wetted parts conductive. Attaching the ground wire to the grounding screw (106) grounds the wetted parts. See **grounding screw** on page 18.

When pumping conductive flammable fluids, **always** ground the entire fluid system by making sure the fluid system has an electrical path to a true earth ground (see Fig. 3). **Never** use a polypropylene or PVDF pump with non-conductive flammable fluids as specified by your local fire protection code.

US Code (NFPA 77 Static Electricity) recommends a conductivity greater than 50×10^{-12} Siemens/meter (mhos/meter) over your operating temperature range to reduce the hazard of fire. Consult your fluid supplier to determine the conductivity or resistivity of your fluid. The resistivity must be less than 2×10^{12} ohm-centimeters.

To reduce the risk of static sparking, ground the pump and all other equipment used or located in the pumping area. Check your local electrical code for detailed grounding instructions for your area and type of equipment.

NOTE: When pumping conductive flammable fluids, **always** ground the fluid system. See the **WARNING** above. Fig. 3 shows a recommended method of grounding flammable fluid containers during filling.

Ground all of this equipment:

- **Pump:** The acetal pump has a grounding screw on the top manifold. Connect the non-clamp end of the ground wire to the grounding strip or grounding screw, and connect the clamp end of the ground wire to a true earth ground. To order a ground wire and clamp, order Part No. 222011.
- **Air and fluid hoses:** Use only electrically conductive hoses.
- **Air compressor:** Follow the manufacturer's recommendations.
- **Solvent pails used when flushing:** Follow the local code. Use only grounded metal pails, which are conductive. Do not place the pail on a non-conductive surface, such as paper or cardboard, which interrupts the grounding continuity.
- **Fluid supply container:** Follow the local code.

GROUNDING A PUMP

KEY

- A Pump
- H Fluid drain valve (required)
- S Dispense valve
- T Fluid drain line
- Y Fluid section grounding via grounding strip or grounding screw (required for metal and acetal pumps)
- Z Container ground wire (required)

- 1 Hose must be conductive.
- 2 Dispense valve nozzle must be in contact with container.

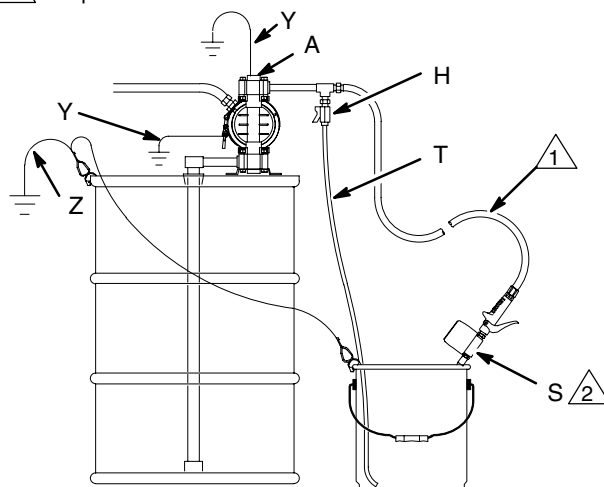



Fig. 3

9079A

Installation

Changing the Orientation of the Fluid Outlet Port

You can change the orientation of the fluid outlet port by repositioning the manifold. See Fig. 4.

1.  **Relieve the pressure.** See **Pressure Relief Procedure** on page 10.
2. Remove the four manifold nuts (109).
3. Turn the manifold to the desired position, reinstall the nuts, and torque to 80 to 90 in-lb (9 to 10 N-m). See **Torque Sequence**, page 20.

NOTE: Make sure all manifold o-rings are positioned correctly before you fasten the manifold. Manifold o-rings (139) are shown in Fig. 6 and Fig. 8.

 Torque to 80 to 90 in-lb (9 to 10 N-m). See **Torque Sequence**, page 20.

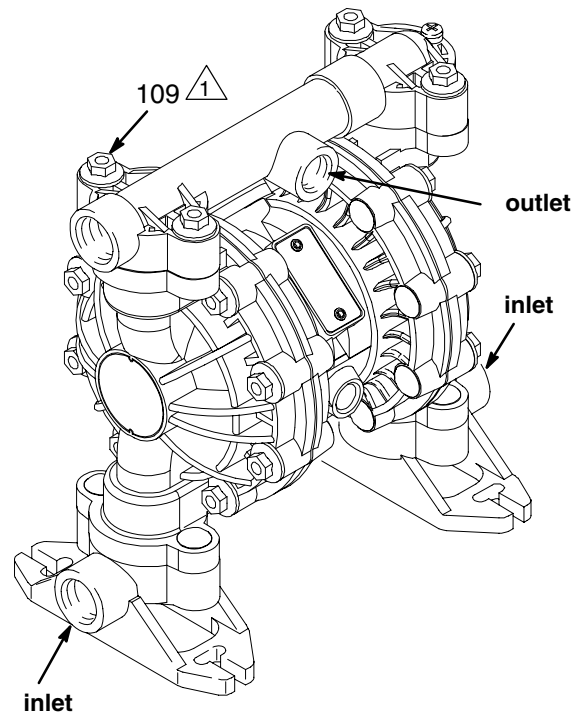

Fig. 4

T10476

Operation

Pressure Relief Procedure

WARNING

PRESSURIZED EQUIPMENT HAZARD

The equipment stays pressurized until pressure is manually relieved. To reduce the risk of serious injury from pressurized fluid, accidental spray, or splashing fluid, follow this procedure whenever you



- Are instructed to relieve pressure
- Stop pumping
- Check, clean, or service any system equipment
- Install or clean fluid nozzles

1. Shut off the air to the pump.
2. Open the dispensing valve, if used.
3. Open the fluid drain valve to relieve all fluid pressure, and have a container ready to catch the drainage.

Flush Pump Before First Use

The pump was tested with lightweight oil which is left in the fluid passages to protect parts. To avoid contaminating your fluid with oil, flush the pump with a compatible solvent before using the equipment. Follow the steps under **Starting and Adjusting Pump**.

Starting and Adjusting Pump

1.   Read **Toxic Fluid Hazard** on page 3.
2.  If lifting the pump, follow the **Pressure Relief Procedure** above.

3.    Be sure the pump is properly grounded. Read **Fire and Explosion Hazard** on page 3.

4. Check all fittings to be sure they are tight. Use a compatible liquid thread sealant on all male threads. Tighten the fluid inlet and outlet fittings snugly. Do not overtighten the fittings into the pump.
5. Place the suction tube (if used) in the fluid to be pumped.

NOTE: If the inlet fluid pressure to the pump is more than 25% of the outlet working pressure, the ball check valves will not close fast enough, resulting in inefficient pump operation.

6. Close the fluid drain valve (H).
7. With the pump air regulator (G) closed, open all bleed-type master air valves (B).
8. If the fluid hose has a dispensing device, hold it open while continuing with the following step. Slowly open the air regulator (G) until the pump starts to cycle. Allow the pump to cycle slowly until all air is pushed out of the lines and the pump is primed.

If you are flushing, run the pump long enough to thoroughly clean the pump and hoses. Close the air regulator. Remove the suction tube from the solvent and place it in the fluid to be pumped.

Pump Shutdown

-  At the end of the work shift, **relieve the pressure** as described in **Pressure Relief Procedure** at left.

Maintenance

Lubrication

The air valve is lubricated at the factory to operate without additional lubrication. If you want to provide additional lubrication, remove the hose from the pump air inlet and add two drops of machine oil to the air inlet every 500 hours of operation or every month.

CAUTION

Do not over-lubricate the pump. Oil is exhausted through the muffler, which could contaminate your fluid supply or other equipment. Excessive lubrication can also cause the pump to malfunction.

Flushing and Storage

Flush the pump to prevent the fluid you are pumping from drying or freezing in the pump and damaging it. Use a compatible solvent.

Always flush the pump and **relieve the pressure** before you store it for any length of time.



Read **Pressure Relief Procedure** on page 10.

Tightening Threaded Connections

Before each use, check all hoses for wear or damage and replace as necessary. Check to be sure all threaded connections are tight and leak-free.

Check fasteners. Tighten or retorque as necessary. Although pump use varies, a general guideline is to retorque fasteners every two months. See **Torque Sequence**, page 20.

Preventive Maintenance Schedule

Establish a preventive maintenance schedule, based on the pump's service history. This is especially important for prevention of spills or leakage due to diaphragm failure.

Troubleshooting



Read **Pressure Relief Procedure** on page 10, and **relieve the pressure** before you check or service the equipment. Check all possible problems and causes before disassembling the pump.

PROBLEM	CAUSE	SOLUTION
Pump will not cycle, or cycles once and stops.	Air valve is stuck or dirty.	Use filtered air.
Pump cycles at stall or fails to hold pressure at stall.	Leaky check valves or o-rings.	Replace.
	Worn check balls or duckbill valves or guides.	Replace.
	Check ball wedged in guide.	Repair or replace.
	Worn diaphragm shaft seals.	Replace.
Pump operates erratically.	Clogged suction line.	Inspect; clear.
	Sticky or leaking check valve balls.	Clean or replace.
	Diaphragm ruptured.	Replace.
Air bubbles in fluid.	Suction line is loose.	Tighten.
	Diaphragm ruptured.	Replace.
	Loose manifolds or damaged manifold o-rings.	Tighten manifold bolts or nuts; replace o-rings.
	Loose fluid side diaphragm plates.	Tighten.
Fluid in exhaust air.	Diaphragm ruptured.	Replace.
	Loose fluid side diaphragm plates.	Tighten.
	Worn diaphragm shaft seals.	Replace.
Pump leaks fluid from check valves.	Worn or damaged check valve o-rings.	Inspect; replace.

Service

Air Valve

NOTE: Air Valve Repair Kit 241657 is available. Order repair kit separately. Parts included in the kit are marked with a dagger (†) in Fig. 5 and in the Parts Drawings and Lists. A tube of general purpose grease 111920 is supplied in the kit. Service the air valve as follows. See Fig. 5.



1. **Relieve the pressure.** See **Pressure Relief Procedure** on page 10.

2. Remove the cover (10) and the o-ring (4).
3. Remove the carriage plungers (7), carriages (8), carriage pins (9), and valve plate (14) from the center housing (11).
4. Clean all the parts, and inspect them for wear or damage.

NOTE: If you are installing the new Air Valve Repair Kit 241657, use all the parts in the kit.

5. Grease the lapped surface of the valve plate (14), and install the valve plate with the lapped surface facing up.
6. Grease the bores of the center housing (11), install the u-cup packings (2) on the carriage plungers (7), and slide the carriage plungers into the carriage plunger bores. See the following important installation notes:

NOTES:

- When you install each u-cup packing (2) on each carriage plunger (7), make sure the lips of the u-cup packing face toward the **clip end** (the smaller end) of the carriage plunger.
 - When you slide the carriage plungers (7) into the bores, slide them in with the clip ends (the smaller ends) facing toward the center of the center housing (11).
7. Grease the carriage pins (9), and slide the carriage pins into the carriage pin bores.
 8. Install the carriages (8). Make sure the carriages engage the clip ends of the carriage plungers (7) and carriage pins (9).
 9. Grease the o-ring (4), and seat it in the groove around the cover opening of the center housing (11).
 10. Screw the cover (10) into the center housing, and torque the cover to 80 to 100 in-lb (9.0 to 13.6 N-m).

NOTE: Center housing (11) is shown separated from the air covers, but it is not necessary to remove the air covers for this service. Leave the center housing and air covers assembled for this service.

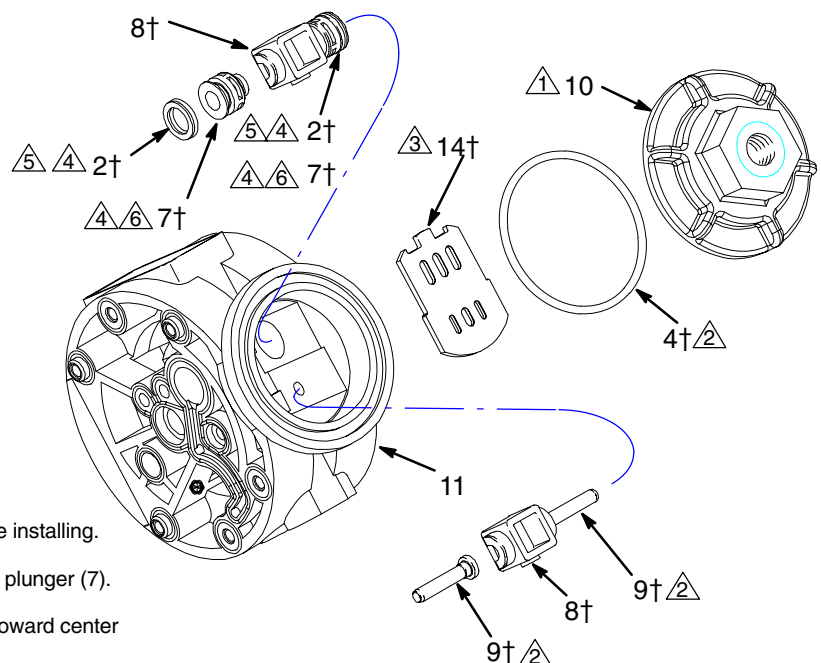

† Included in Air Valve Repair Kit 241657

1. Torque to 80 to 100 in-lb (9.0 to 13.6 N-m).
2. Apply grease.
3. Apply grease to lapped face.
4. Apply grease to bores of center housing (11) before installing.
5. Seal lips face clip end (the smaller end) of carriage plunger (7).
6. Install with the clip ends (the smaller ends) facing toward center of center housing (11).

Fig. 5

9069A

Service

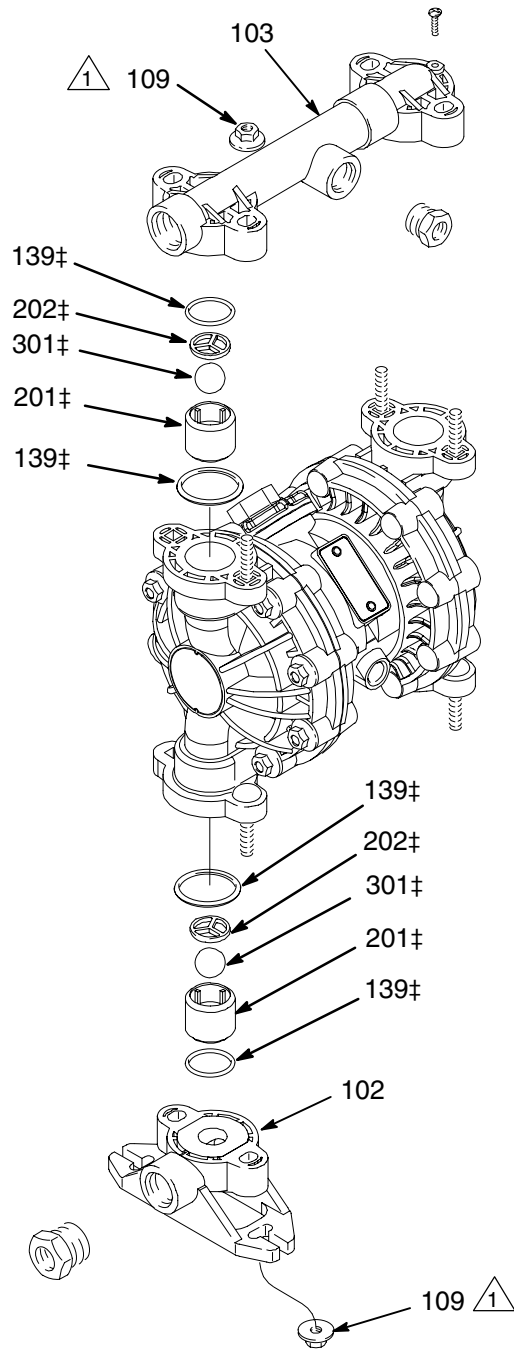

 Torque to 80 to 90 in-lb (9 to 10 N-m). See **Torque Sequence**, page 20.

Fig. 6

TI0479

Service

Diaphragms

NOTE: Fluid Section Repair Kit D05277 is available. Order repair kit separately. Parts included in the kit are marked with a double dagger (‡) in Fig. 7 and in the Parts Drawings and Lists. General purpose grease 111920 and Adhesive 113500 are supplied in the kit. Service the diaphragms as follows. See Fig. 7.

Disassembly



1. **Relieve the pressure.** See **Pressure Relief Procedure** on page 10.

2. Remove manifolds (102 and 103) and fluid covers (101).

NOTE: Make sure all the check valve parts stay in place. See Fig. 6 on page 14.

3. Remove one of the fluid-side diaphragm plates (105) (whichever one comes loose first when you use a wrench on the hex of each), and pull the diaphragm shaft (15) out of the center housing (11).
4. Use a wrench on the flats of the diaphragm shaft (15) to remove the other fluid-side diaphragm plate (105) from the diaphragm shaft.
5. Remove the screws (106), remove the left (114) and right (113) air covers, and remove all old gasket (12) material from the ends of the center housing (11) and the surfaces of the air covers.
6. Remove the diaphragm shaft u-cups (16) and pilot pin o-rings (1).
7. Inspect all parts for wear or damage, and replace as necessary.

Reassembly

1. Insert a diaphragm shaft u-cup (16) and a pilot pin o-ring (1) into the bores of the center housing (11).

NOTE: Make sure the lips of the u-cup face **out** of the center housing.

2. Line up the holes in the gasket (12) with the holes in the end of the center housing (11), and use six screws (106) to fasten an air cover (113 or 114) to the end of the center housing (11). Torque the screws to 35 to 45 in-lb (4.0 to 5.1 N-m).
3. Position the exhaust cover (13) and o-ring (4) on the center housing (11).
4. Repeat steps 1 and 2 for the other end of the center housing and the remaining air cover.
5. Apply medium-strength (blue) Loctite or equivalent to the threads of the fluid-side diaphragm plates (105). Install on one end of the diaphragm shaft (15) the following parts (see proper order in Fig. 7): air-side diaphragm plate (6) diaphragm (401), and fluid-side diaphragm plate (105).
NOTE: The words "AIR SIDE" on the diaphragm (401) and the flat side of the air-side diaphragm plate (6) must face toward the diaphragm shaft (15)
6. Put grease on the diaphragm shaft (15), and carefully (do not damage the shaft u-cups) run the diaphragm shaft (15) through the center housing (11) bore.
7. Repeat step 5 for the other end of the diaphragm shaft (15), and torque the fluid-side diaphragm plates (105) to 80 to 90 in-lb (9 to 10 N-m) at 100 rpm maximum.
8. Install the muffler (3).
9. Make sure all the check valve parts are in place. See Fig. 6 on page 14.
10. Reinstall the fluid covers (101) and manifolds (102 and 103), and torque the fluid cover and manifold nuts (109) to 80 to 90 in-lb (9 to 10 N-m). See **Torque Sequence**, page 20.

Service

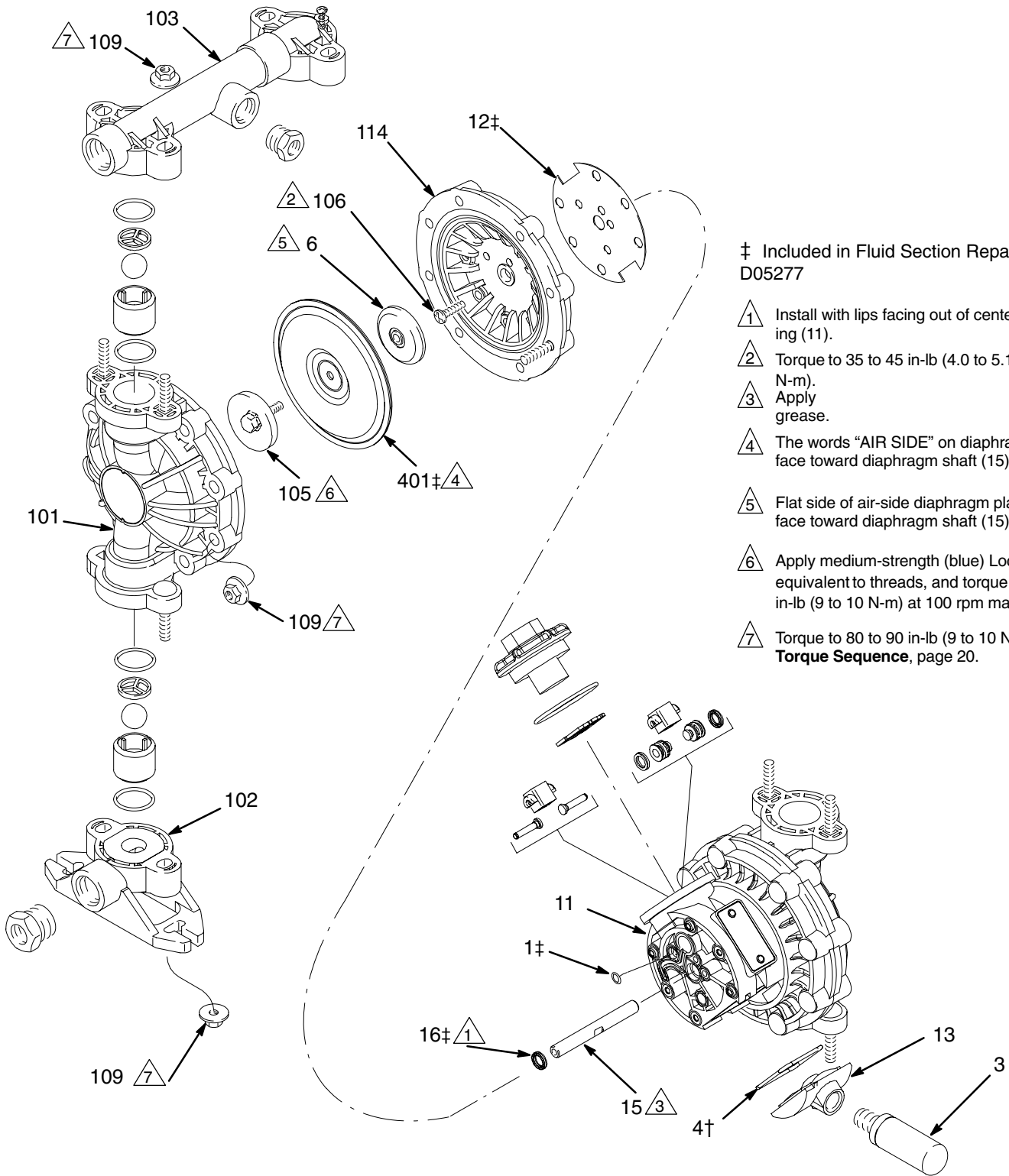

Fig. 7

T10481

Parts

† Included in Air Valve Repair Kit 241657

‡ Included in Fluid Section Repair Kit D05277

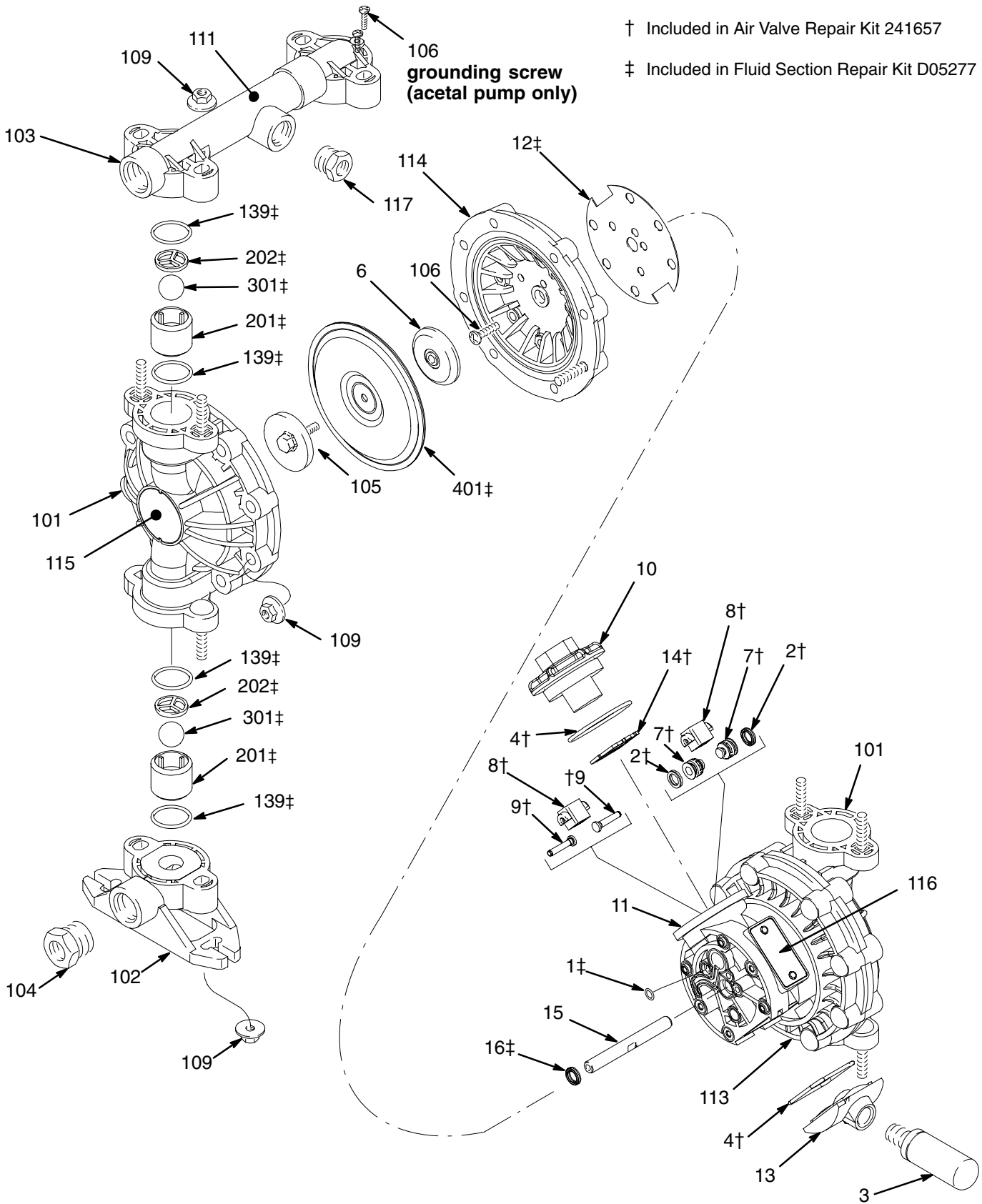

T10481

Parts

Ref. No.	Part No.	Description	Qty	Ref. No.	Part No.	Description	Qty
1‡	114866	PACKING, o-ring	2	105	187711	PLATE, diaphragm, fluid; acetal	2
2†	108808	PACKING, u-cup	2	106	114882	SCREW, torx	13
3	112933	MUFFLER	1	109	114850	NUT, hex, large flng	24
4†	162942	PACKING, o-ring	2	111	187732	LABEL, warning	1
6	195025	PLATE, diaphragm, air side	2	113	192599	COVER, air, right	1
7†	15Y825	PLUNGER, carriage	2	114	192600	COVER, air, left	1
8†	192595	CARRIAGE	2	115	194352	LABEL, identification	2
9†	192596	PIN, carriage	2	116	290045	PLATE, designation	1
10	192597	COVER, valve chamber	1	117	194359	PLUG; acetal; 1/2 NPT	1
11	192602	HOUSING, center	1	119	111183	RIVET (not shown for plate 116)	2
12‡	192765	GASKET	2	139‡	114849	PACKING, o-ring; encapsulated	8
13	194247	COVER, exhaust	1	201‡	186691	GUIDE; acetal	4
14†	194269	PLATE, valve	1	202‡	186692	STOP; acetal	4
15	192601	SHAFT, diaphragm	1	301‡	108944	BALL; buna-N	4
16‡	108808	PACKING, u-cup	2	401‡	190148	DIAPHRAGM; buna-N	2
101	192559	COVER, fluid; acetal	2				
102	194347	MANIFOLD, inlet; acetal; NPT	2				
103	192562	MANIFOLD, outlet; acetal; NPT	1				
104	194362	PLUG; acetal; 3/4 NPT	2				

† Included in Air Valve Repair Kit 241657

‡ Included in Fluid Section Repair Kit D05277

Torque Sequence

Always follow torque sequence when instructed to torque fasteners.

1. Left/Right Fluid Covers
Torque bolts to 80–90 in-lb (9–10 N•m)

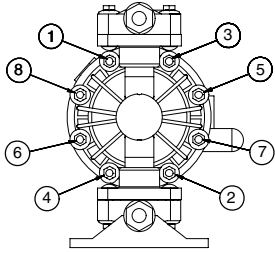

SIDE VIEW

3. Outlet Manifold
Torque bolts to 80–90 in-lb (9–10 N•m)

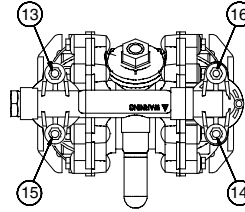

TOP VIEW

2. Inlet Manifold
Torque bolts to 80–90 in-lb (9–10 N•m)

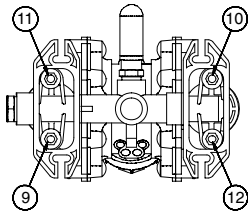

BOTTOM VIEW

Technical Data

Maximum fluid working pressure	100 psi (0.7 MPa, 7 bar)
Air pressure operating range	30 to 100 psi (0.2 to 0.7 MPa, 2.1 to 7 bar)
Maximum air consumption	28 scfm (0.672 cubic meters/min.)
Maximum free flow delivery (1/2 in. ports)	15 gpm (57 l/min)
Maximum pump speed	400 cpm
Gallons (Liters) per cycle	0.04 (0.15)
Maximum suction lift (water w/buna balls)	15 ft (4.5 m) dry, 25 ft (7.6 m) wet
Maximum size pumpable solids	3/32 in. (2.5 mm)
Sound power level (measured per ISO standard 9614-2)	
At 70 psig (0.48 MPa, 4.8 bar) at 50 cycles per minute	77 dBa
At 100 psig (0.7 MPa, 7 bar) at maximum cycles per minute	95 dBa
Sound pressure level (measured 1 meter from pump)	
At 70 psig (0.48 MPa, 4.8 bar) at 50 cycles per minute	67 dBa
At 100 psig (0.7 MPa, 7 bar) at maximum cycles per minute	85 dBa
Air inlet size	1/4 npt(f)
Air exhaust port size	3/8 npt(f)
Fluid inlet size.	3/4 in. npt(f)
Fluid outlet size.	1/2 and 3/4 in. npt(f)
Wetted parts.	Groundable Acetal, Buna-N, PTFE
Non-wetted parts.	Polypropylene, Stainless Steel, Polyester and Aluminum, Nickel Plated Brass
Weight (approximate)	7.8 lb (3.5 kg)

Loctite® is a registered trademark of the Loctite Corporation.

Dimensions

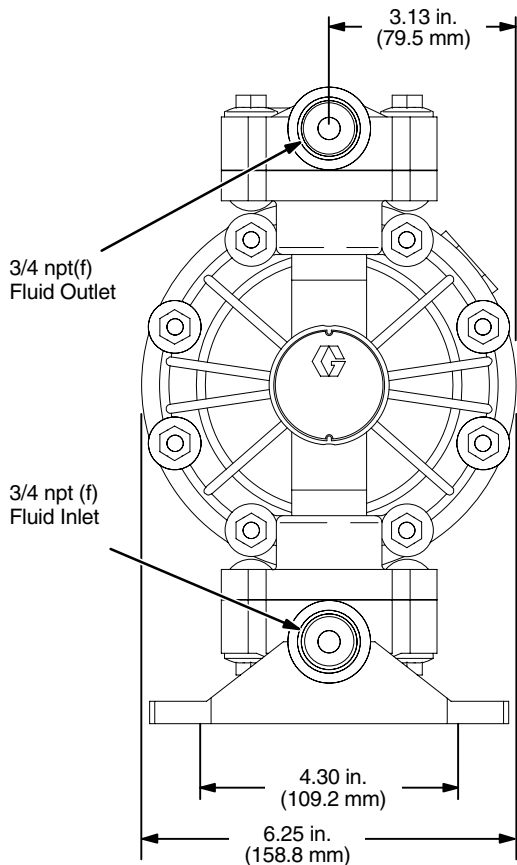
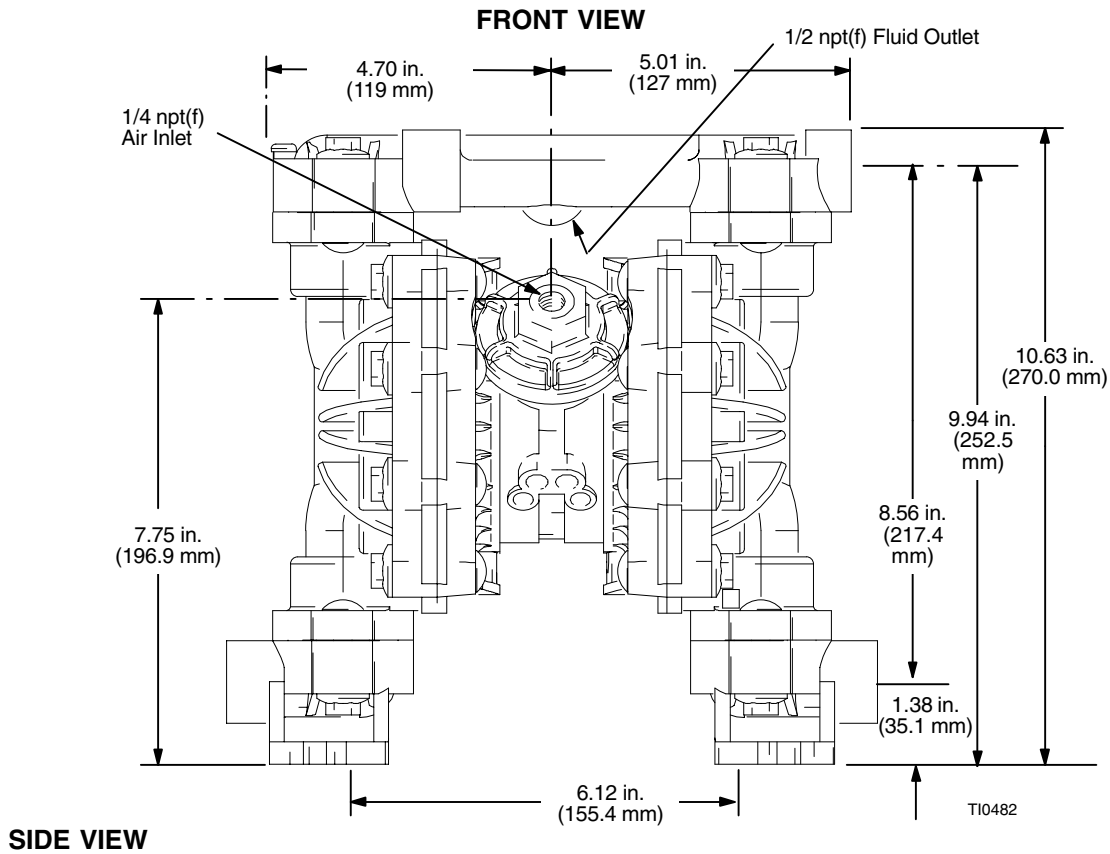

PUMP MOUNTING HOLE PATTERN

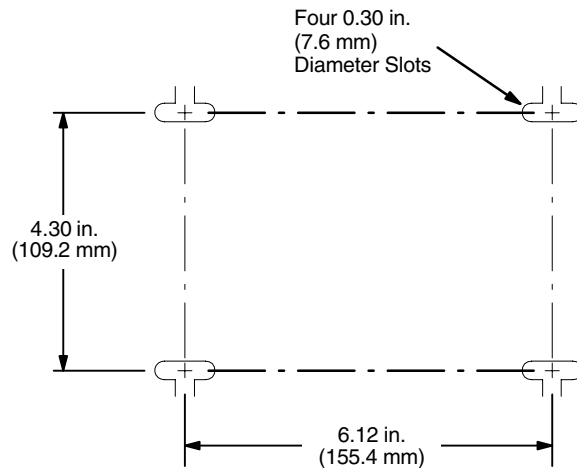

9077A

Performance Charts

Fluid Outlet Pressure

Test Conditions: Pump tested in water with inlet submerged.

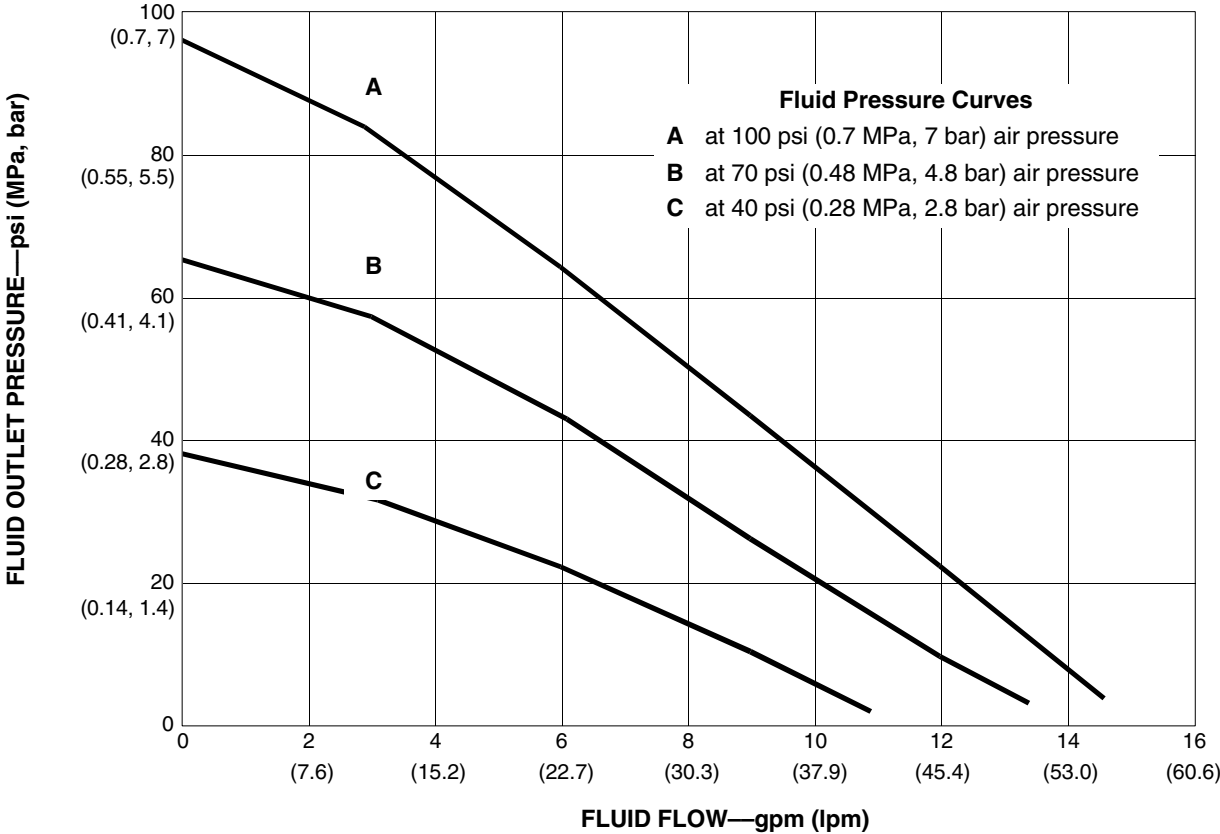

To find Fluid Outlet Pressure (psi/MPa/bar) at a specific fluid flow (gpm/lpm) and operating air pressure (psi/MPa/bar):

1. Locate fluid flow rate along bottom of chart.
2. Follow vertical line up to intersection with selected fluid outlet pressure curve.
3. Follow left to scale to read fluid outlet pressure.

Performance Charts

Air Consumption

Test Conditions: Pump tested in water with inlet submerged.

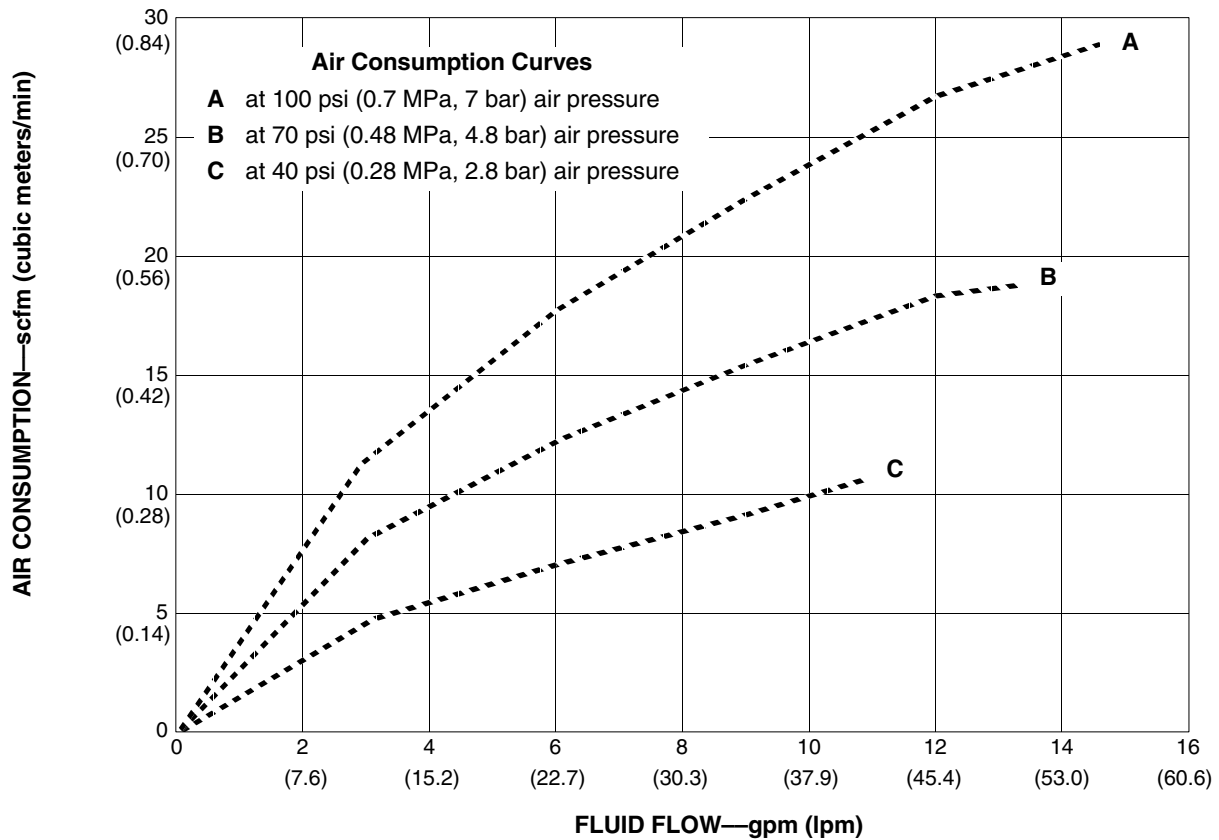

To find Pump Air Consumption (scfm or m³/min) at a specific fluid flow (gpm/lpm) and air pressure (psi/MPa/bar):

1. Locate fluid flow rate along bottom of chart.
2. Read vertical line up to intersection with selected air consumption curve.
3. Follow left to scale to read air consumption.