

# Instructions



## Air-Operated Diaphragm Pumps

308981Y

ENG

*For fluid transfer applications. For professional use only.*

*100 psi (0.7 MPa, 7 bar) Maximum Fluid Working Pressure*

*100 psi (0.7 MPa, 7 bar) Maximum Air Input Pressure*

**ACETAL, POLYPROPYLENE, AND PVDF**

### Husky™ 515

Model No. D 5 1 \_\_\_ Acetal NPT Pumps\*

Model No. D 5 2 \_\_\_ Polypropylene Pumps

Model No. D 5 5 \_\_\_ PVDF NPT Pumps

Model No. D 5 A \_\_\_ Acetal BSPT Pumps\*

Model No. D 5 B \_\_\_ Polypropylene BSPT Pumps

Model No. D 5 E \_\_\_ PVDF BSPT Pumps

For Additional Models, see Table of Contents

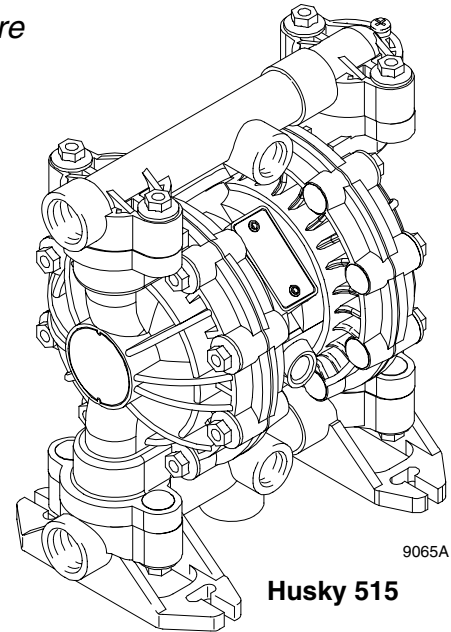

9065A

Husky 515

**ALUMINUM AND STAINLESS STEEL\***

### Husky™ 716

Model No. D 5 3 \_\_\_ Aluminum NPT Pumps

Model No. D 5 4 \_\_\_ Stainless Steel NPT Pumps

Model No. D 5 C \_\_\_ Aluminum BSPT Pumps

Model No. D 5 D \_\_\_ Stainless Steel BSPT Pumps

For Additional Models, see Table of Contents

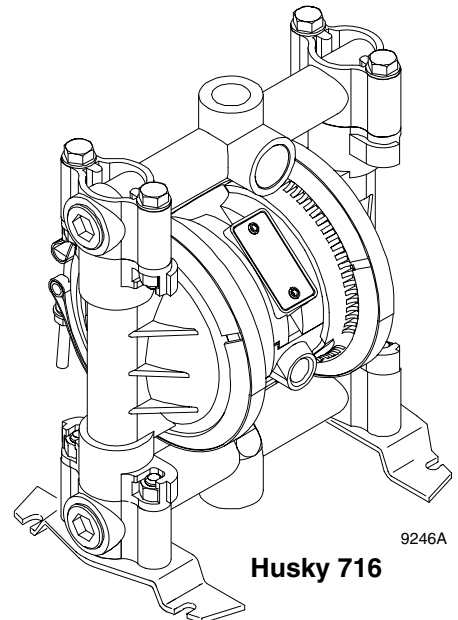

9246A

Husky 716

\*These models are  certified.

Patents Pending



#### Important Safety Instructions

Read all warnings and instructions in this manual.  
Save these instructions.

Refer to the Pump Matrix on page 20 to determine  
the model number of your pump.



HO03

PROVEN QUALITY. LEADING TECHNOLOGY.

# Table of Contents

Safety Warnings .....	2
Installation .....	4
Operation .....	10
Maintenance .....	11
Troubleshooting .....	12
Service .....	13
Husky 515 and Husky 716 Pump Matrix .....	20
Husky 515 and 715 Additional Pumps .....	21
Husky 515 and Husky 716 Repair Kits .....	21
<b>Parts</b>	
Husky 515 and Husky 716 Common Parts .....	22
Husky 515 Parts Drawing .....	23
Husky 515 Fluid Section Parts List .....	24
Husky 716 Parts Drawing .....	25
Husky 716 Fluid Section Parts List .....	26
Torque Sequence .....	27
<b>Husky 515:</b>	
Technical Data .....	28
Dimensions .....	29
<b>Husky 716:</b>	
Technical Data .....	30
Dimensions .....	31
Husky 515 and Husky 716 Performance Charts ...	32
Graco Standard Warranty .....	34
Graco Information .....	34

# Symbols

## Warning Symbol



This symbol alerts you to the possibility of serious injury or death if you do not follow the instructions.

## Caution Symbol



This symbol alerts you to the possibility of damage to or destruction of equipment if you do not follow the instructions.

# ! WARNING



INSTRUCTIONS

## EQUIPMENT MISUSE HAZARD

Equipment misuse can cause the equipment to rupture or malfunction and result in serious injury.

- This equipment is for professional use only.
- Read all instruction manuals, tags, and labels before operating the equipment.
- Use the equipment only for its intended purpose. If you are not sure, call your Graco distributor.
- Do not alter or modify this equipment. Use only genuine Graco parts and accessories.
- Check equipment daily. Repair or replace worn or damaged parts immediately.
- Do not exceed the maximum working pressure of the lowest rated component in your system. This equipment has a **100 psi (0.7 MPa, 7 bar) maximum working pressure at 100 psi (0.7 MPa, 7 bar) maximum incoming air pressure.**
- Use fluids and solvents that are compatible with the equipment wetted parts. Refer to the **Technical Data** section of all equipment manuals. Read the fluid and solvent manufacturer's warnings.
- Route hoses away from traffic areas, sharp edges, moving parts, and hot surfaces. Do not expose Graco hoses to temperatures above 82°C (180°F) or below -40°C (-40°F).
- Wear hearing protection when operating this equipment.
- Do not lift pressurized equipment.
- Do not kink or overbend hoses or use hoses to pull equipment.
- Comply with all applicable local, state, and national fire, electrical, and safety regulations.
- Do not use 1.1.1-trichloroethane, methylene chloride, other halogenated hydrocarbon solvents or fluids containing such solvents in pressurized aluminum equipment. Such use could result in a chemical reaction, with the possibility of explosion.

# WARNING



## TOXIC FLUID HAZARD

Hazardous fluid or toxic fumes can cause serious injury or death if splashed in the eyes or on the skin, inhaled, or swallowed.

- Know the specific hazards of the fluid you are using.
- Do not lift a pump under pressure. If dropped, the fluid section may rupture. Always follow the **Pressure Relief Procedure** on page 10 before lifting the pump.
- Store hazardous fluid in an approved container. Dispose of hazardous fluid according to all local, state, and national guidelines.
- Always wear protective eyewear, gloves, clothing, and respirator as recommended by the fluid and solvent manufacturer.
- Pipe and dispose of the exhaust air safely, away from people, animals, and food handling areas. If the diaphragm fails, the fluid is exhausted along with the air. Read **Air Exhaust Ventilation** on page 6.
- **Never** use an acetal pump to pump acids. Take precautions to avoid acid or acid fumes from contacting the pump housing exterior. Stainless steel parts will be damaged by exposure to acid spills and fumes.



## FIRE AND EXPLOSION HAZARD

Improper grounding, poor ventilation, open flames, or sparks can cause a hazardous condition and result in a fire or explosion and serious injury.

- Ground the equipment. Refer to **Grounding** on page 8.
- **Never** use a polypropylene or PVDF pump with non-conductive flammable fluids as specified by your local fire protection code. Refer to **Grounding** on page 8 for additional information. Consult your fluid supplier to determine the conductivity or resistivity of your fluid.
- If there is any static sparking or you feel an electric shock while using this equipment, **stop pumping immediately**. Do not use the equipment until you identify and correct the problem.
- Provide fresh air ventilation to avoid the buildup of flammable fumes from solvents or the fluid being pumped.
- Pipe and dispose of the exhaust air safely, away from all sources of ignition. If the diaphragm fails, the fluid is exhausted along with the air. Read **Air Exhaust Ventilation** on page 6.
- Keep the work area free of debris, including solvent, rags, and gasoline.
- Electrically disconnect all equipment in the work area.
- Extinguish all open flames or pilot lights in the work area.
- Do not smoke in the work area.
- Do not turn on or off any light switch in the work area while operating or if fumes are present.
- Do not operate a gasoline engine in the work area.
- Keep a fire extinguisher in the work area.

# Installation

## General Information

- The Typical Installations in Fig. 2 are only guides for selecting and installing system components. Contact your Graco distributor for assistance in planning a system to suit your needs.
- Always use Genuine Graco Parts and Accessories.
- Use a compatible, liquid thread sealant on all male threads. Tighten all connections firmly to avoid air or fluid leaks.

## Tightening Threaded Fasteners Before First Use

Before using the pump for the first time, check and retorque all external fasteners. See **Torque Sequence**, page 27. After the first day of operation, retorque the fasteners. Although pump use varies, a general guideline is to retorque fasteners every two months.

## Toxic Fluid Hazard



Read **Toxic Fluid Hazard** on page 3.

Use fluids and solvents that are compatible with the equipment wetted parts. Refer to the **Technical Data** section of all equipment manuals. Read the fluid and solvent manufacturer's warnings.

## CAUTION

### Safe Operating Temperatures

*Minimum (all pumps): 40° F (4° C)*

*Maximum*

*Acetal: 180° F (82° C)*

*Polypropylene: 150° F (66° C)*

*Aluminum, stainless steel, PVDF: 225° F (107° C)*

These temperatures are based upon mechanical stress only and may be significantly altered by pumping certain chemicals. Consult engineering guides for chemical compatibilities and temperature limits, or contact your Graco distributor.

## Mountings

- These pumps can be used in a variety of installations. Be sure the mounting surface can support the weight of the pump, hoses, and accessories, as well as the stress caused during operation.
- Fig. 2 shows some installation examples. On all installations, mount the pump using screws and nuts.

## Pumping High-Density Fluids

High density fluids may prevent the lighter non-metallic check valve balls from seating properly, which reduces pump performance significantly. Stainless steel balls should be used for such applications.

## Split Manifolds

Plastic Split Manifold Kits are available to enable you to pump two fluids simultaneously or to mix two fluids in the pump. To order a Split Manifold Kit, use the Part No. from the list below:

- 241240** polypropylene; split inlet
- 241241** acetal; split inlet
- 241242** PVDF; split inlet
- 241243** polypropylene; split outlet
- 241244** acetal; split outlet
- 241245** PVDF; split outlet

# Installation

## Air Line

### **WARNING**

A bleed-type master air valve (B) is required in your system to relieve air trapped between this valve and the pump. See Fig. 2. Trapped air can cause the pump to cycle unexpectedly, which could result in serious injury, including splashing in the eyes or on the skin, injury from moving parts, or contamination from hazardous fluids.

### **CAUTION**

The pump exhaust air may contain contaminants. Ventilate to a remote area if the contaminants could affect your fluid supply. Read **Air Exhaust Ventilation** on page 6.

1. Install the air line accessories as shown in Fig. 2. Mount these accessories on the wall or on a bracket. Be sure the air line supplying the accessories is electrically conductive.
  - a. The fluid pressure can be controlled in either of two ways. To control it on the air side, install an air regulator (G). To control it on the fluid side, install a fluid regulator (J) near the pump fluid outlet (see Fig. 2).
  - b. Locate one bleed-type master air valve (B) close to the pump and use it to relieve trapped air. Read the **WARNING** above. Locate the other master air valve (E) upstream from all air line accessories and use it to isolate them during cleaning and repair.
  - c. The air line filter (F) removes harmful dirt and moisture from the compressed air supply.
2. Install an electrically conductive, flexible air hose (C) between the accessories and the 1/4 npt(f) pump air inlet. Use a minimum 1/4 in. (6.3 mm) ID air hose. Screw an air line quick disconnect coupler (D) onto the end of the air hose (C), and screw the mating fitting into the pump air inlet snugly. Do not connect the coupler (D) to the fitting yet.

## Installation of Remote Pilot Air Lines

1. Refer to Parts Drawings. Connect air line to pump as in preceding steps.
2. Connect 1/4 in. O.D. tubing to push type connectors (16) on underside of pump.

**NOTE:** by replacing the push type connectors, other sizes or types of fittings may be used. The new fittings will require 1/8 in. npt threads.

3. Connect remaining ends of tubes to external air signal, such as Graco's Cycleflo (P/N 195264) or Cycleflo II (P/N195265) controllers.

**NOTE:** the air pressure at the connectors must be at least 30% of the air pressure to the air motor for the pump to operate.

## Fluid Suction Line

- If using a conductive (acetal) pump, use conductive hoses. If using a non-conductive pump, ground the fluid system. Read **Grounding** on page 8. The fluid inlet port is 1/2 in. or 3/4 in.
- At inlet fluid pressures greater than 15 psi (0.1 MPa, 1 bar), diaphragm life will be shortened.

## Fluid Outlet Line

### **WARNING**

A fluid drain valve (H) is required in your system to relieve pressure in the hose if it is plugged. See Fig. 2. The drain valve reduces the risk of serious injury, including splashing in the eyes or on the skin, or contamination from hazardous fluids when relieving pressure. Install the valve close to the pump fluid outlet.

1. Use electrically conductive fluid hoses (K). The pump fluid outlet is 1/2 in. or 3/4 in. Screw the fluid fitting into the pump outlet snugly. **Do not over-tighten.**
2. Install a fluid regulator (J) at the pump fluid outlet to control fluid pressure, if desired (see Fig. 2). See **Air Line**, step 1a, for another method of controlling pressure.
3. Install a fluid drain valve (H) near the fluid outlet. Read the **WARNING** above.

# Installation



## Fluid Pressure Relief Valve

### CAUTION

Some systems may require installation of a pressure relief valve at the pump outlet to prevent overpressurization and rupture of the pump or hose. See Fig. 1.

Thermal expansion of fluid in the outlet line can cause overpressurization. This can occur when using long fluid lines exposed to sunlight or ambient heat, or when pumping from a cool to a warm area (for example, from an underground tank).

Overpressurization can also occur if the Husky pump is being used to feed fluid to a piston pump, and the intake valve of the piston pump does not close, causing fluid to back up in the outlet line.

-  1 Install valve between fluid inlet and outlet ports.
-  2 Connect fluid inlet line here.
-  3 Connect fluid outlet line here.

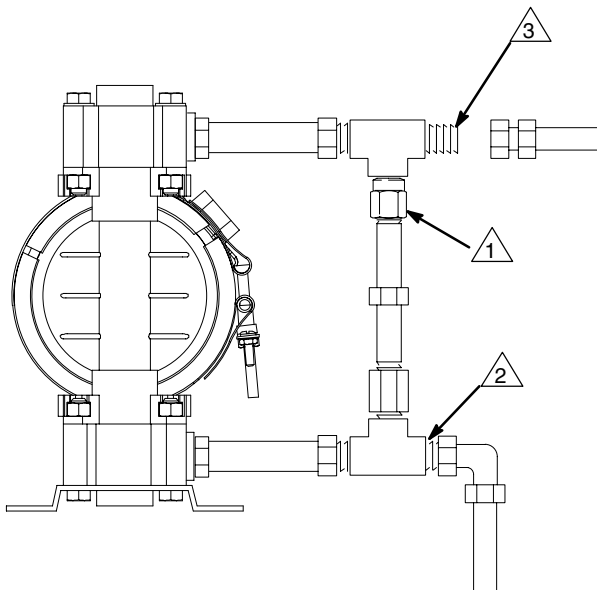

Fig. 1

9073A

## Air Exhaust Ventilation



Read **Toxic Fluid Hazard** on page 3.



Read **Fire and Explosion Hazard** on page 3.

Be sure the system is properly ventilated for your type of installation. You must vent the exhaust to a safe place, away from people, animals, food handling areas, and all sources of ignition when pumping flammable or hazardous fluids.

Diaphragm failure will cause the fluid being pumped to exhaust with the air. Place an appropriate container at the end of the air exhaust line to catch the fluid. See Fig. 2 .

The air exhaust port is 3/8 npt(f). Do not restrict the air exhaust port. Excessive exhaust restriction can cause erratic pump operation.

See **Venting Exhaust Air** in Fig. 2. Exhaust to a remote location as follows:

1. Remove the muffler (W) from the pump air exhaust port.
2. Install an electrically conductive air exhaust hose (X) and connect the muffler to the other end of the hose. The minimum size for the air exhaust hose is 3/8 in. (10 mm) ID. If a hose longer than 15 ft (4.57 m) is required, use a larger diameter hose. Avoid sharp bends or kinks in the hose.
3. Place a container (Z) at the end of the air exhaust line to catch fluid in case a diaphragm ruptures. See Fig. 2.

# Installation

## ABOVE-GROUND TRANSFER INSTALLATION

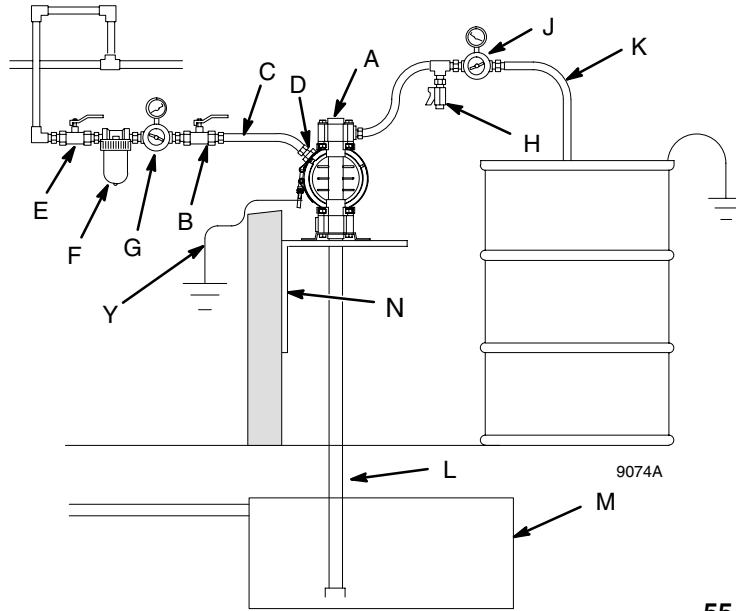

### KEY

- A Pump
- B Bleed-type master air valve (required for pump)
- C Electrically conductive air supply line
- D Air line quick disconnect
- E Master air valve (for accessories)
- F Air line filter
- G Pump air regulator
- H Fluid drain valve (required)
- J Fluid regulator (optional)
- K Electrically conductive fluid supply hose
- L Fluid suction line
- M Underground storage tank
- N Wall mounting bracket
- Y Ground wire (required; see page 8 for installation instructions)

## 55-GALLON BUNG PUMP INSTALLATION

### KEY

- A Pump
- C Electrically conductive air supply line
- D Air line quick disconnect
- H Fluid drain valve (required)
- K Electrically conductive fluid supply hose
- L Fluid suction line
- Y Ground wire (required; see page 8 for installation instructions)

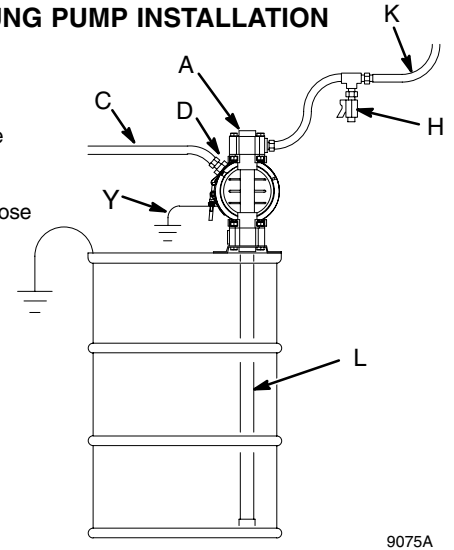

## AIR SPRAY INSTALLATION

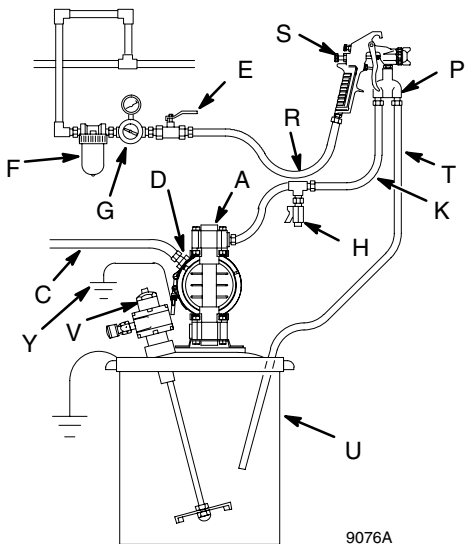

### KEY

- A Pump
- C Electrically conductive air line to pump
- E Gun air line shutoff valve
- F Air line filter
- G Gun air regulator
- H Fluid drain valve (required)
- K Electrically conductive fluid supply hose
- P Circulating valve
- R Electrically conductive air line to gun
- S Air spray gun
- T Electrically conductive fluid return line
- U 5-gallon pail
- V Agitator
- Y Ground wire (required; see page 8 for installation instructions)

### KEY

- W Muffler
- X Electrically Conductive Air Exhaust Hose
- Z Container for Remote Air Exhaust

All wetted and non-wetted pump parts must be compatible with the fluid being pumped.

## VENTING EXHAUST AIR

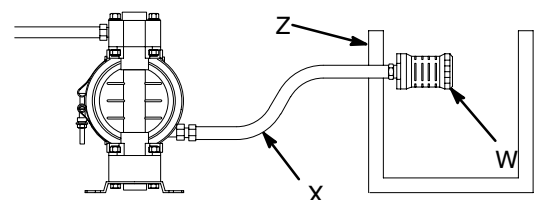

Fig. 2

04054

# Installation

## Grounding

### WARNING



#### FIRE AND EXPLOSION HAZARD

This pump must be grounded. Before operating the pump, ground the system as explained below. Also read the section **Fire and Explosion Hazard** on page 3.

The *acetal Husky 515 pump* contains stainless steel fibers, which makes the wetted parts conductive. Attaching the ground wire to the grounding screw (106) grounds the wetted parts. See **grounding screw** on page 23.

The *metal Husky 716 pumps* have a grounding strip connecting the vee clamps (109). Attach a ground wire to the grounding strip with the screw, lockwasher, and nut as shown in the **Grounding Detail** on page 25.

The *polypropylene and PVDF Husky 515 pumps* are **not** conductive.

When pumping conductive flammable fluids, **always** ground the entire fluid system by making sure the fluid system has an electrical path to a true earth ground (see Fig. 3). **Never** use a polypropylene or PVDF pump with non-conductive flammable fluids as specified by your local fire protection code.

US Code (NFPA 77 Static Electricity) recommends a conductivity greater than  $50 \times 10^{-12}$  Siemens/meter (mhos/meter) over your operating temperature range to reduce the hazard of fire. Consult your fluid supplier to determine the conductivity or resistivity of your fluid. The resistivity must be less than  $2 \times 10^{12}$  ohm-centimeters.

To reduce the risk of static sparking, ground the pump and all other equipment used or located in the pumping area. Check your local electrical code for detailed grounding instructions for your area and type of equipment.

**NOTE:** When pumping conductive flammable fluids with a polypropylene or PVDF pump, **always** ground the fluid system. See the **WARNING** above. Fig. 3 shows a recommended method of grounding flammable fluid containers during filling.

#### Ground all of this equipment:

- **Pump:** The metal pump has a grounding strip in front of the center housing. The acetal pump has a grounding screw on the top manifold. Connect the non-clamp end of the ground wire to the grounding strip or grounding screw, and connect the clamp end of the ground wire to a true earth ground. To order a ground wire and clamp, order Part No. 222011.
- **Air and fluid hoses:** Use only electrically conductive hoses.
- **Air compressor:** Follow the manufacturer's recommendations.
- **Solvent pails used when flushing:** Follow the local code. Use only grounded metal pails, which are conductive. Do not place the pail on a non-conductive surface, such as paper or cardboard, which interrupts the grounding continuity.
- **Fluid supply container:** Follow the local code.

#### GROUNDING A PUMP

##### KEY

- A Pump
- H Fluid drain valve (required)
- S Dispense valve
- T Fluid drain line
- Y Fluid section grounding via grounding strip or grounding screw (required for metal and acetal pumps)
- Z Container ground wire (required)

- 1 Hose must be conductive.
- 2 Dispense valve nozzle must be in contact with container.

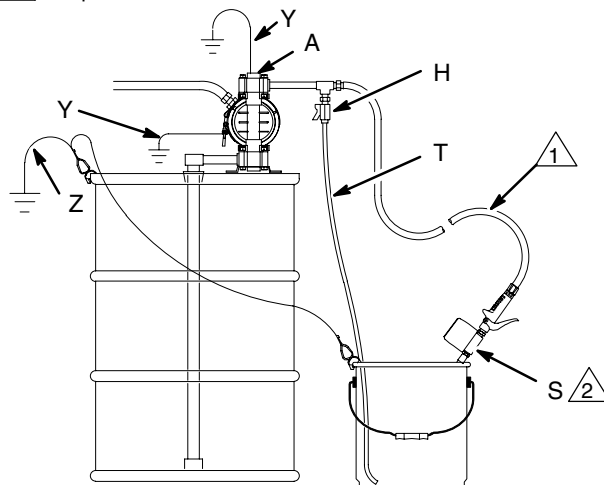

Fig. 3

9079A

# Installation

## Changing the Orientation of the Fluid Inlet and Outlet Ports (Husky 515)

You can change the orientation of the fluid inlet and outlet ports by repositioning the manifolds. For Husky 515, see Fig. 4. For Husky 716, see Fig. 5.

1.  **Relieve the pressure.** See **Pressure Relief Procedure** on page 10.

2. Remove the four manifold nuts (109) or bolts (105).
3. Turn the manifold to the desired position, reinstall the nuts or bolts, and torque to 80 to 90 in-lb (9 to 10 N•m). See **Torque Sequence**, page 27.

**NOTE:** Make sure all manifold o-rings are positioned correctly before you fasten the manifold. Manifold o-rings (139) are shown in Fig. 7 and Fig. 8.

**NOTE:** Pumps with duckbill check valves are shipped with the inlet manifold on top and the outlet manifold on the bottom. See page 14 for details.

 Torque to 80 to 90 in-lb (9 to 10 N•m). See **Torque Sequence**, page 27.

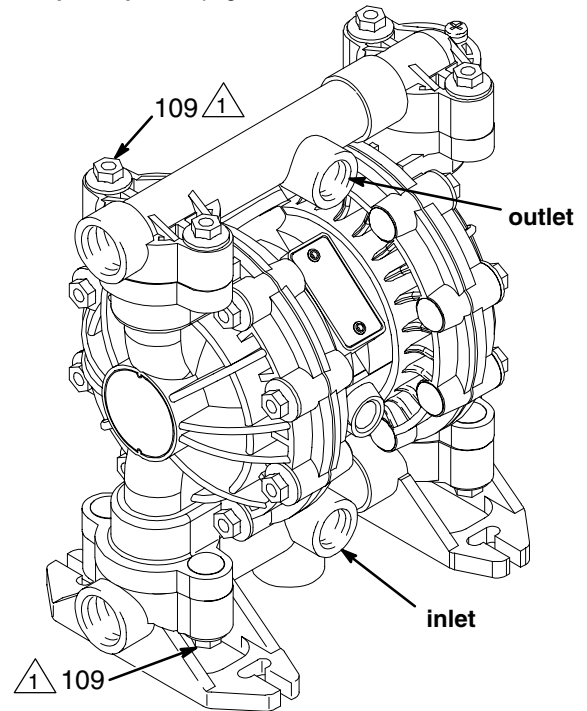



Fig. 4

9065A

 Torque to 80 to 90 in-lb (9 to 10 N•m). See **Torque Sequence**, page 27.

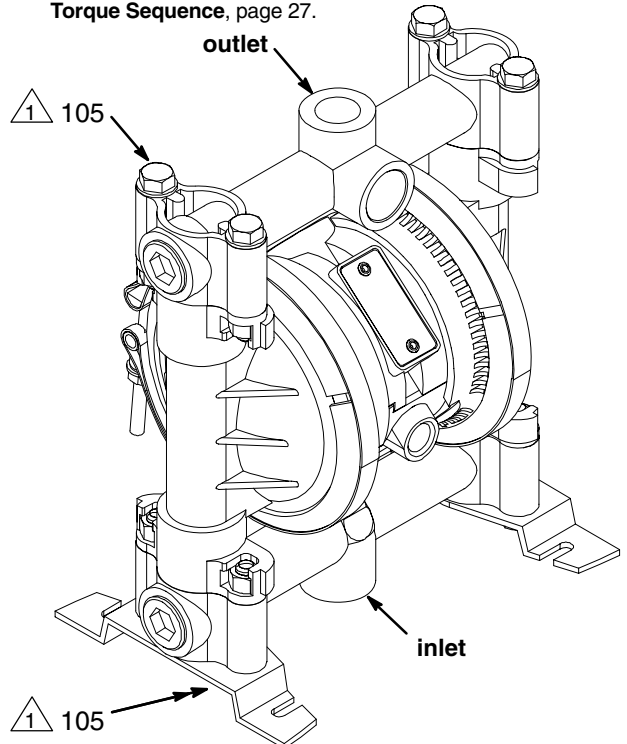

Fig. 5

9071A

# Operation

## Pressure Relief Procedure

### **WARNING**

#### **PRESSURIZED EQUIPMENT HAZARD**

The equipment stays pressurized until pressure is manually relieved. To reduce the risk of serious injury from pressurized fluid, accidental spray, or splashing fluid, follow this procedure whenever you







- Are instructed to relieve pressure
- Stop pumping
- Check, clean, or service any system equipment
- Install or clean fluid nozzles

1. Shut off the air to the pump.
2. Open the dispensing valve, if used.
3. Open the fluid drain valve to relieve all fluid pressure, and have a container ready to catch the drainage.

## Flush Pump Before First Use

The pump was tested with lightweight oil, which is left in the fluid passages to protect parts. To avoid contaminating your fluid with oil, flush the pump with a compatible solvent before using the equipment. Follow the steps under **Starting and Adjusting Pump**.

## Starting and Adjusting Pump

1.   Read **Toxic Fluid Hazard** on page 3.
2.  If lifting the pump, follow the **Pressure Relief Procedure** above.
3.    Be sure the pump is properly grounded. Read **Fire and Explosion Hazard** on page 3.
4. Check all fittings to be sure they are tight. Use a compatible liquid thread sealant on all male threads. Tighten the fluid inlet and outlet fittings snugly. Do not overtighten the fittings into the pump.
5. Place the suction tube (if used) in the fluid to be pumped.

10 308981

**NOTE:** If the inlet fluid pressure to the pump is more than 25% of the outlet working pressure, the ball check valves will not close fast enough, resulting in inefficient pump operation.

6. Place the end of the fluid hose (K) into an appropriate container.
7. Close the fluid drain valve (H).
8. With the pump air regulator (G) closed, open all bleed-type master air valves (B, E).
9. If the fluid hose has a dispensing device, hold it open while continuing with the following step. Slowly open the air regulator (G) until the pump starts to cycle. Allow the pump to cycle slowly until all air is pushed out of the lines and the pump is primed.

*If you are flushing*, run the pump long enough to thoroughly clean the pump and hoses. Close the air regulator. Remove the suction tube from the solvent and place it in the fluid to be pumped.

## Operation of Remote Piloted Pumps

1. Fig. 2 and Parts Drawings. Follow preceding steps 1 through 8 of **Starting and Adjusting Pump**.
2. Open air regulator (G).

### **WARNING**

The pump may cycle once before the external signal is applied. Injury is possible. If pump cycles, wait until end before proceeding.

3. Pump will operate when air pressure is alternately applied to push type connectors (16).

**NOTE:** Leaving air pressure applied to the air motor for extended periods when the pump is not running may shorten the diaphragm life. Using a 3-way solenoid valve to automatically relieve the pressure on the air motor when the metering cycle is complete prevents this from occurring.

## Pump Shutdown



At the end of the work shift, **relieve the pressure** as described in **Pressure Relief Procedure** at left.

# Maintenance

## Lubrication

The air valve is lubricated at the factory to operate without additional lubrication. If you want to provide additional lubrication, remove the hose from the pump air inlet and add two drops of machine oil to the air inlet every 500 hours of operation or every month.

### CAUTION

Do not over-lubricate the pump. Oil is exhausted through the muffler, which could contaminate your fluid supply or other equipment. Excessive lubrication can also cause the pump to malfunction.

## Flushing and Storage

Flush the pump to prevent the fluid you are pumping from drying or freezing in the pump and damaging it. Use a compatible solvent.

Always flush the pump and **relieve the pressure** before you store it for any length of time.



Read **Pressure Relief Procedure** on page 10.

## Tightening Threaded Connections

Before each use, check all hoses for wear or damage and replace as necessary. Check to be sure all threaded connections are tight and leak-free.

Check fasteners. Tighten or retorque as necessary. Although pump use varies, a general guideline is to retorque fasteners every two months. See **Torque Sequence**, page 27.

## Preventive Maintenance Schedule

Establish a preventive maintenance schedule, based on the pump's service history. This is especially important for prevention of spills or leakage due to diaphragm failure.

# Troubleshooting



Read **Pressure Relief Procedure** on page 10, and **relieve the pressure** before you check or service the equipment. Check all possible problems and causes before disassembling the pump.

PROBLEM	CAUSE	SOLUTION
Pump will not cycle, or cycles once and stops.	Air valve is stuck or dirty.	Use filtered air.
Pump cycles at stall or fails to hold pressure at stall.	Leaky check valves or o-rings.	Replace.
	Worn check balls or duckbill valves or guides.	Replace.
	Check ball wedged in guide.	Repair or replace.
	Worn diaphragm shaft seals.	Replace.
Pump operates erratically.	Clogged suction line.	Inspect; clear.
	Sticky or leaking check valve balls.	Clean or replace.
	Diaphragm ruptured.	Replace.
Air bubbles in fluid.	Suction line is loose.	Tighten.
	Diaphragm ruptured.	Replace.
	Loose manifolds or damaged manifold o-rings.	Tighten manifold bolts or nuts; replace o-rings.
	Loose fluid side diaphragm plates.	Tighten.
Fluid in exhaust air.	Diaphragm ruptured.	Replace.
	Loose fluid side diaphragm plates.	Tighten.
	Worn diaphragm shaft seals.	Replace.
Pump exhausts air from clamps (metal pumps).	Loose clamps.	Tighten clamp nuts.
	Air valve o-ring is damaged.	Inspect; replace.
Pump leaks fluid from check valves.	Worn or damaged check valve o-rings.	Inspect; replace.

# Service

## Air Valve (Husky 515 and Husky 716 Pumps)

**NOTE:** Air Valve Repair Kit 241657 is available. Parts included in the kit are marked with a dagger (†) in Fig. 6 and in the Parts Drawings and Lists. A tube of general purpose grease 111920 is supplied in the kit. Service the air valve as follows. See Fig. 6.



1. **Relieve the pressure.** See **Pressure Relief Procedure** on page 10.

2. Remove the cover (10) and the o-ring (4).
3. Remove the carriage plungers (7), carriages (8), carriage pins (9), and valve plate (14) from the center housing (11).
4. Clean all the parts, and inspect them for wear or damage.

**NOTE:** If you are installing the new Air Valve Repair Kit 241657, use all the parts in the kit.

5. Grease the lapped surface of the valve plate (14), and install the valve plate with the lapped surface facing up.
6. Grease the bores of the center housing (11), install the u-cup packings (2) on the carriage plungers (7), and slide the carriage plungers into the carriage plunger bores. See the following important installation notes:

### NOTES:

- When you install each u-cup packing (2) on each carriage plunger (7), make sure the lips of the u-cup packing face toward the **clip end** (the smaller end) of the carriage plunger.
  - When you slide the carriage plungers (7) into the bores, slide them in with the clip ends (the smaller ends) facing toward the center of the center housing (11).
7. Grease the carriage pins (9), and slide the carriage pins into the carriage pin bores.
  8. Install the carriages (8). Make sure the carriages engage the clip ends of the carriage plungers (7) and carriage pins (9).
  9. Grease the o-ring (4), and seat it in the groove around the cover opening of the center housing (11).
  10. Screw the cover (10) into the center housing, and torque the cover to 80 to 100 in-lb (9.0 to 13.6 N-m).

**NOTE:** Center housing (11) is shown separated from the air covers, but it is not necessary to remove the air covers for this service. Leave the center housing and air covers assembled for this service.

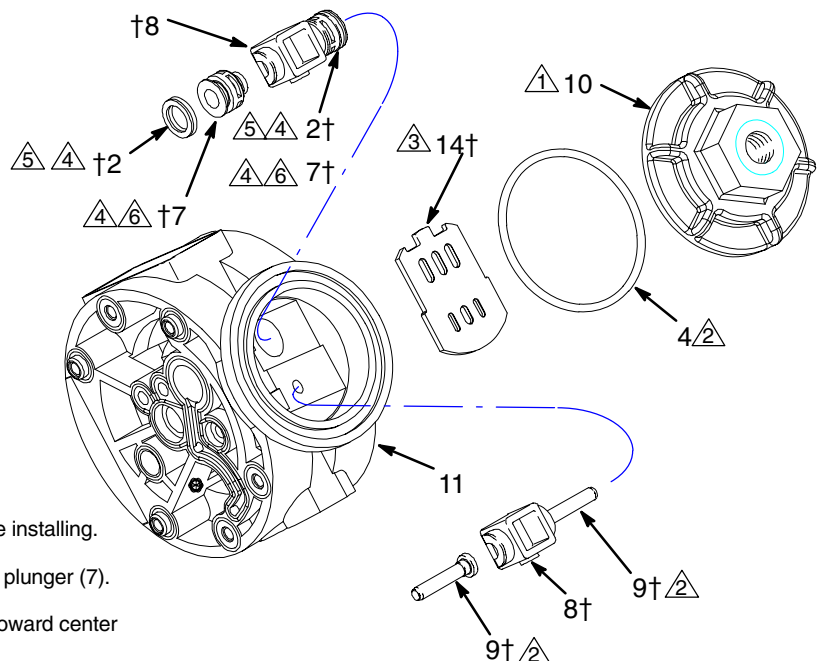

† Included in Air Valve Repair Kit 241657

1. Torque to 80 to 100 in-lb (9.0 to 13.6 N-m).
2. Apply grease.
3. Apply grease to lapped face.
4. Apply grease to bores of center housing (11) before installing.
5. Seal lips face clip end (the smaller end) of carriage plunger (7).
6. Install with the clip ends (the smaller ends) facing toward center of center housing (11).

Fig. 6

9069A

# Service

## Ball or Duckbill Check Valves

**NOTE:** Fluid Section Repair Kit D05XXX is available. See page 21 to order the correct kit for your pump. Parts included in the kit are marked with a double dagger (‡) in Fig. 7 and Fig. 8 and in the Parts Drawings and Lists. General purpose grease 111920 and Adhesive 113500 are supplied in the kit.



1. **Relieve the pressure.** See **Pressure Relief Procedure** on page 10.

2. Remove the top and bottom manifolds (102, 103).
3. Remove all parts shown with a dagger (‡) in Fig. 7 and Fig. 8.
4. Clean all parts, and replace worn or damaged parts.
5. Reassemble the pump.

**NOTE:** Torque the manifold nuts (109) or bolts (105) to 80 to 90 in-lb (9 to 10 N•m). See **Torque Sequence**, page 27.

## Inlet and Outlet for Pumps with Duckbill Check Valves

Pumps with duckbill check valves are shipped with the inlet manifold on top and the outlet manifold on the bottom. To make the inlet manifold on the bottom and the outlet manifold on the top, rotate each of the four duckbill assemblies vertically 180° as shown below.

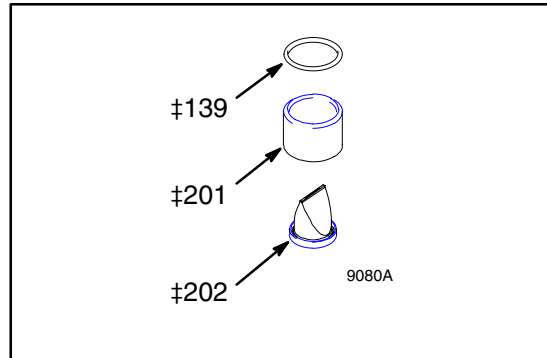

# Service

## Husky 515

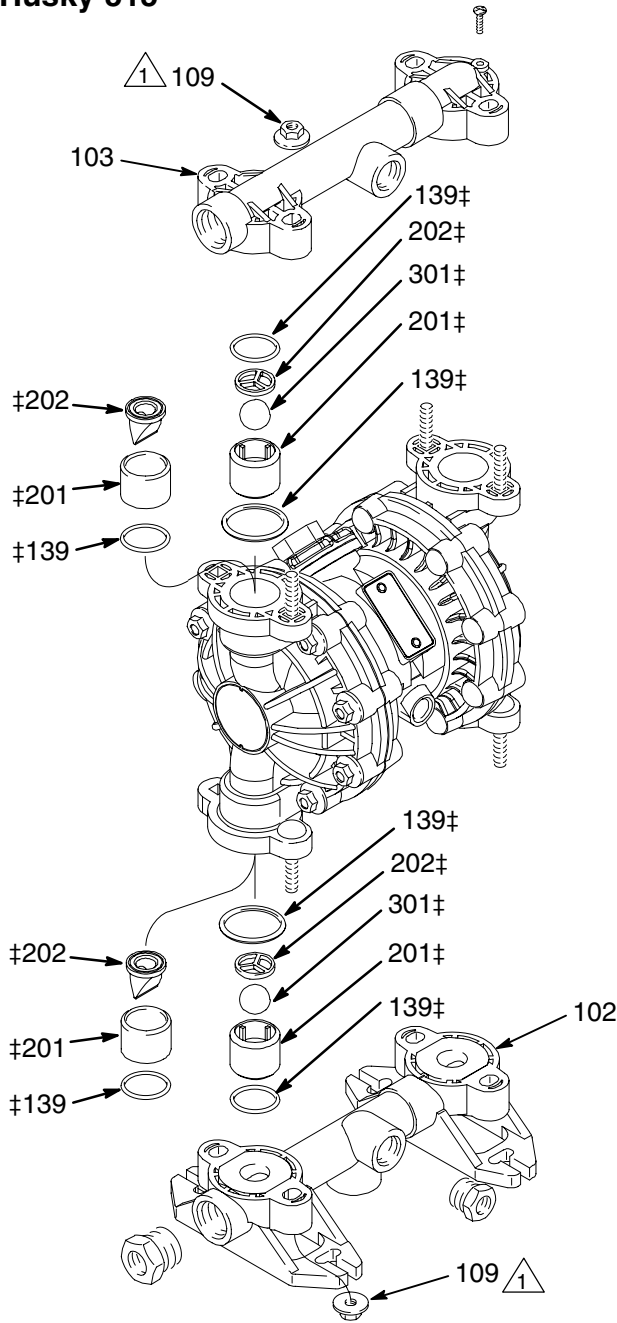

**1** Torque to 80 to 90 in-lb (9 to 10 N-m). See **Torque Sequence**, page 27.

**Fig. 7**

9067A

## Husky 716

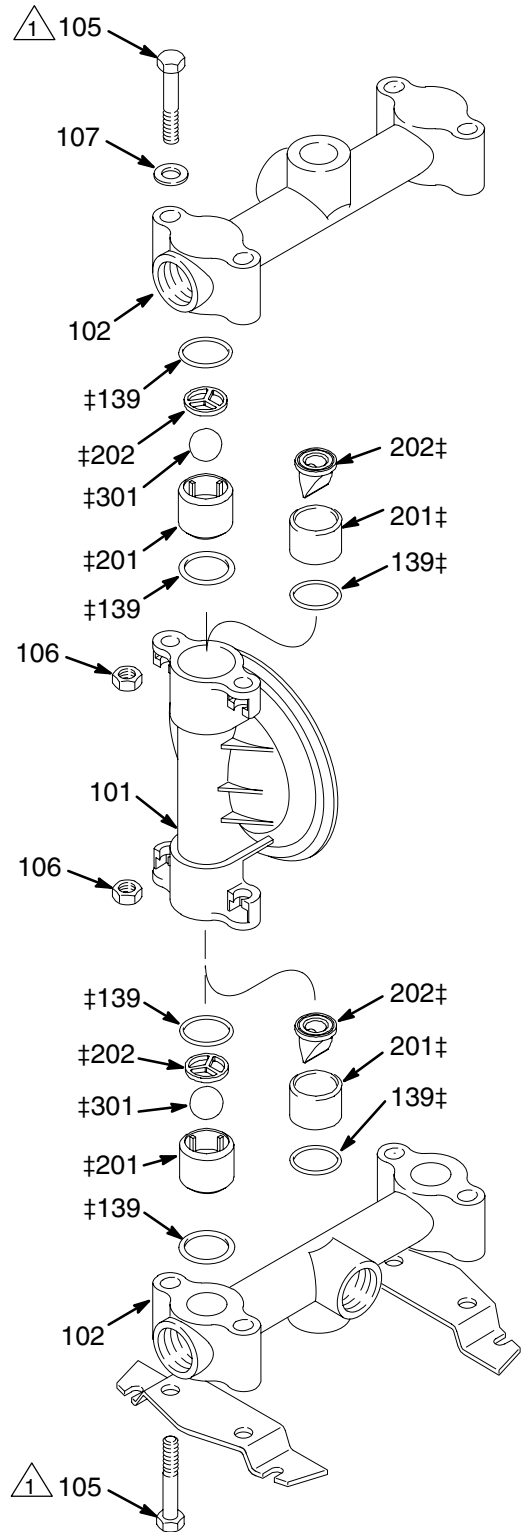

**1** Torque to 80 to 90 in-lb (9 to 10 N-m). See **Torque Sequence**, page 27.

**Fig. 8**

9081A

# Service

## Diaphragms (Husky 515)

**NOTE:** Fluid Section Repair Kit D05XXX is available. See page 21 to order the correct kit for your pump. Parts included in the kit are marked with a double dagger (‡) in Fig. 9 and in the Parts Drawings and Lists. General purpose grease 111920 and Adhesive 113500 are supplied in the kit. Service the diaphragms as follows. See Fig. 9.

### Disassembly



1. **Relieve the pressure.** See **Pressure Relief Procedure** on page 10.

2. Remove manifolds (102 and 103) and fluid covers (101).

**NOTE:** Make sure all the check valve parts stay in place. See Fig. 7 on page 15.

3. Remove one of the fluid-side diaphragm plates (105) (whichever one comes loose first when you use a wrench on the hex of each), and pull the diaphragm shaft out of the center housing (11).
4. Use a wrench on the flats of the diaphragm shaft (15) to remove the other fluid-side diaphragm plate (105) from the diaphragm shaft.
5. Remove the screws (106), remove the left (114) and right (113) air covers, and remove all old gasket (12) material from the ends of the center housing (11) and the surfaces of the air covers.
6. Remove the diaphragm shaft u-cups (416) and pilot pin o-rings (1).
7. Inspect all parts for wear or damage, and replace as necessary.

### Reassembly

1. Insert a diaphragm shaft u-cup (416) and a pilot pin o-ring (1) into the bores of the center housing (11).

**NOTE:** Make sure the lips of the u-cup face **out** of the center housing.

2. Line up the holes in the gasket (12) with the holes in the end of the center housing (11), and use six screws (106) to fasten an air cover (113 or 114) to the end of the center housing (11). Torque the screws to 35 to 45 in-lb (4.0 to 5.1 N-m).
3. Position the exhaust cover (13) and o-ring (4) on the center housing (11).
4. Repeat steps 1 and 2 for the other end of the center housing and the remaining air cover.
5. Apply medium-strength (blue) Loctite or equivalent to the threads of the fluid-side diaphragm plates (105). Install on one end of the diaphragm shaft (15) the following parts (see proper order in Fig. 9): air-side diaphragm plate (6), backup diaphragm (402, used only on models with PTFE diaphragms), diaphragm (401), and fluid-side diaphragm plate (105).  
**NOTE:** The words "AIR SIDE" on the diaphragm (401), the backup diaphragm (402, used only on models with PTFE diaphragms) and the flat side of the air-side diaphragm plate (6) must face toward the diaphragm shaft (15)
6. Put grease on the diaphragm shaft (15), and carefully (do not damage the shaft u-cups) run the diaphragm shaft (15) through the center housing (11) bore.
7. Repeat step 5 for the other end of the diaphragm shaft (15), and torque the fluid-side diaphragm plates (105) to 80 to 90 in-lb (9 to 10 N-m) at 100 rpm maximum.
8. Install the muffler (3).
9. Make sure all the check valve parts are in place. See Fig. 7 on page 15.
10. Reinstall the fluid covers (101) and manifolds (102 and 103), and torque the fluid cover and manifold nuts (109) to 80 to 90 in-lb (9 to 10 N-m). See **Torque Sequence**, page 27.

# Service

## Diaphragms (Husky 515)

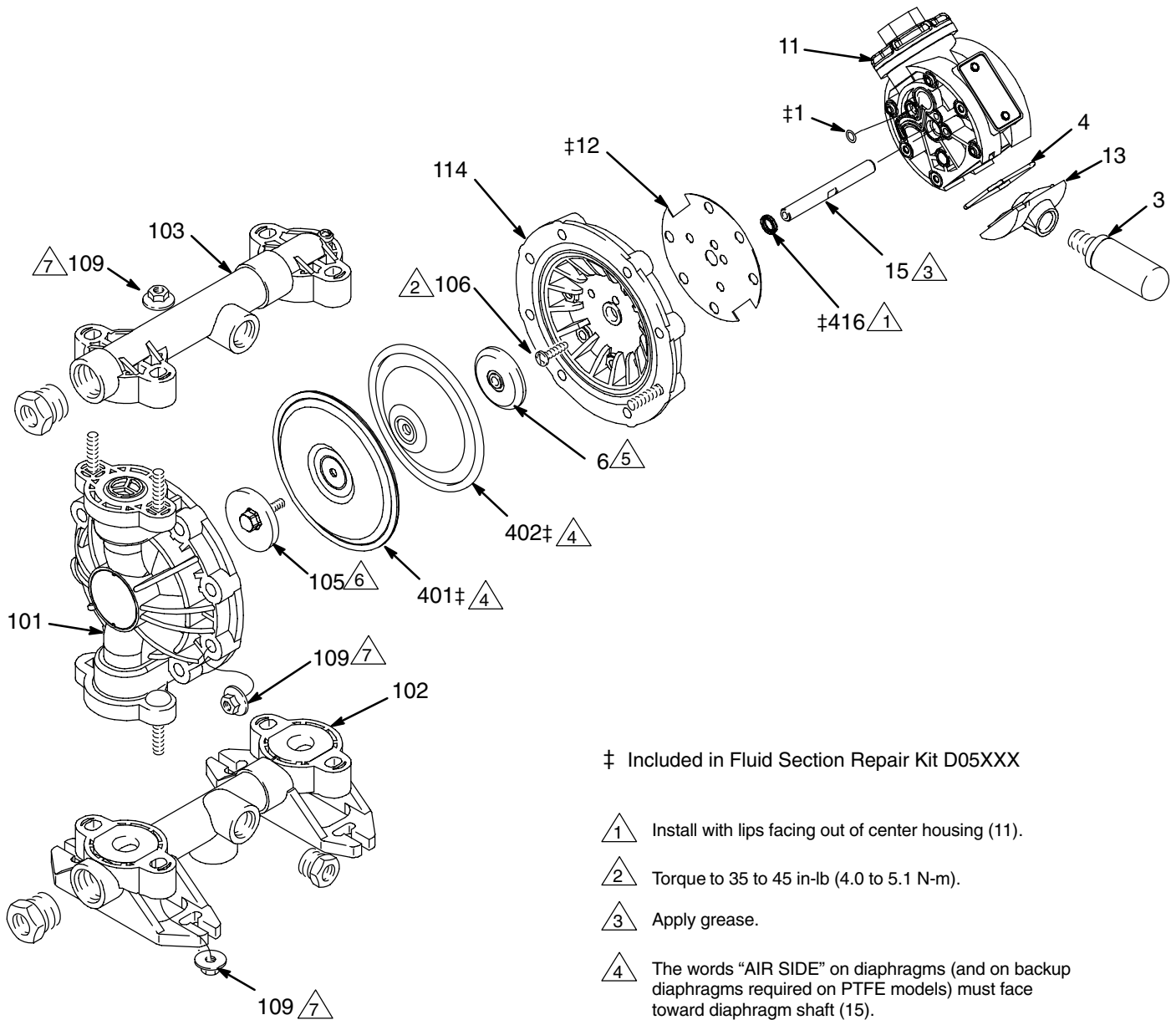

‡ Included in Fluid Section Repair Kit D05XXX

- 1 Install with lips facing out of center housing (11).
- 2 Torque to 35 to 45 in-lb (4.0 to 5.1 N-m).
- 3 Apply grease.
- 4 The words "AIR SIDE" on diaphragms (and on backup diaphragms required on PTFE models) must face toward diaphragm shaft (15).
- 5 Flat side of air-side diaphragm plate must face toward diaphragm shaft (15).
- 6 Apply medium-strength (blue) Loctite® or equivalent to threads, and torque to 80 to 90 in-lb (9 to 10 N-m) at 100 rpm maximum.
- 7 Torque to 80 to 90 in-lb (9 to 10 N-m). See **Torque Sequence**, page 27.

Fig. 9

# Service

## Diaphragms (Husky 716)

**NOTE:** Fluid Section Repair Kit D05XXX is available. See page 21 to order the correct kit for your pump. Parts included in the kit are marked with a double dagger (‡) in Fig. 10 and in the Parts Drawings and Lists. General purpose grease 111920 and Adhesive 113500 are supplied in the kit. Service the diaphragms as follows. See Fig. 10.

### Disassembly



1. **Relieve the pressure.** See **Pressure Relief Procedure** on page 10.

2. Remove the manifolds (102) and fluid covers (101).

**NOTE:** Make sure all the check valve parts stay in place. See Fig. 8 on page 15.

3. Remove the grounding strip from the vee clamps (109), and remove the vee clamps.
4. Remove one of the fluid-side diaphragm plates (133) (whichever one comes loose first when you use a wrench on the hex of each), and pull the diaphragm shaft out of the center housing (11).
5. Use a wrench on the flats of the diaphragm shaft (15) to remove the other fluid-side diaphragm plate (133) from the diaphragm shaft.
6. Remove the screws (141) and air covers (136), and remove all old gasket (12) material from the ends of the center housing (11) and the surfaces of the air covers.
7. Remove the diaphragm shaft u-cups (416) and pilot pin o-rings (1).
8. Inspect all parts for wear or damage, and replace as necessary.

### Reassembly

1. Insert a diaphragm shaft u-cup (416) and a pilot pin o-ring (1) into the end of the diaphragm shaft bore of the center housing (11).

**NOTE:** Make sure the lips of the u-cup face **out** of the center housing.

2. Line up the holes in the gasket (12) with the holes in the end of the center housing (11), and use six screws (141) to fasten an air cover (136) to the end of the center housing (11). Torque the screws to 35 to 45 in-lb (4.0 to 5.1 N-m).

3. Position the exhaust cover (13) and o-ring (4) on the center housing (11).

4. Repeat steps 1 and 2 for the other end of the center housing and the remaining air cover.

5. Apply medium-strength (blue) Loctite or equivalent to the threads of the screws (140). Install on one end of the diaphragm shaft (15) the following parts (see proper order in Fig. 10): air-side diaphragm plate (6), backup diaphragm (402, used only on models with PTFE diaphragms), diaphragm (401), fluid-side diaphragm plate (133), o-ring (115), and screw (140).

**NOTE:** The words “AIR SIDE” on the diaphragm (401), the backup diaphragm (402, used only on models with PTFE diaphragms), and the flat side of the air-side diaphragm plate (6) must face toward the diaphragm shaft (15).

6. Put grease on the diaphragm shaft (15), and carefully (do not damage the shaft u-cups) run the diaphragm shaft (15) through the center housing (11) bore.
7. Repeat step 5 for the other end of the diaphragm shaft (15), and torque the diaphragm shaft screws (140) to 80 to 90 in-lb (9 to 10 N-m) at 100 rpm maximum.
8. Install the muffler (3).

When you install the vee clamps in step 10, orient the center housing (11) so the air inlet is approximately 45° above horizontal and the muffler (3) is approximately horizontal.

9. Apply thin, even film of grease to inside of vee clamp (109).

10. Position the fluid covers (101), install the vee clamps (109) around the fluid and air covers, install the grounding strip on the vee clamps, and torque the vee clamp nuts to 80 to 90 in-lb (9 to 10 N-m). See **Torque Sequence**, page 27.

11. Make sure all the check valve parts are in place. See Fig. 8 on page 15.

12. Install the manifolds (102), and torque the manifold bolts (105) to 80 to 90 in-lb (9 to 10 N-m). See **Torque Sequence**, page 27.

# Service

## Diaphragms (Husky 716)

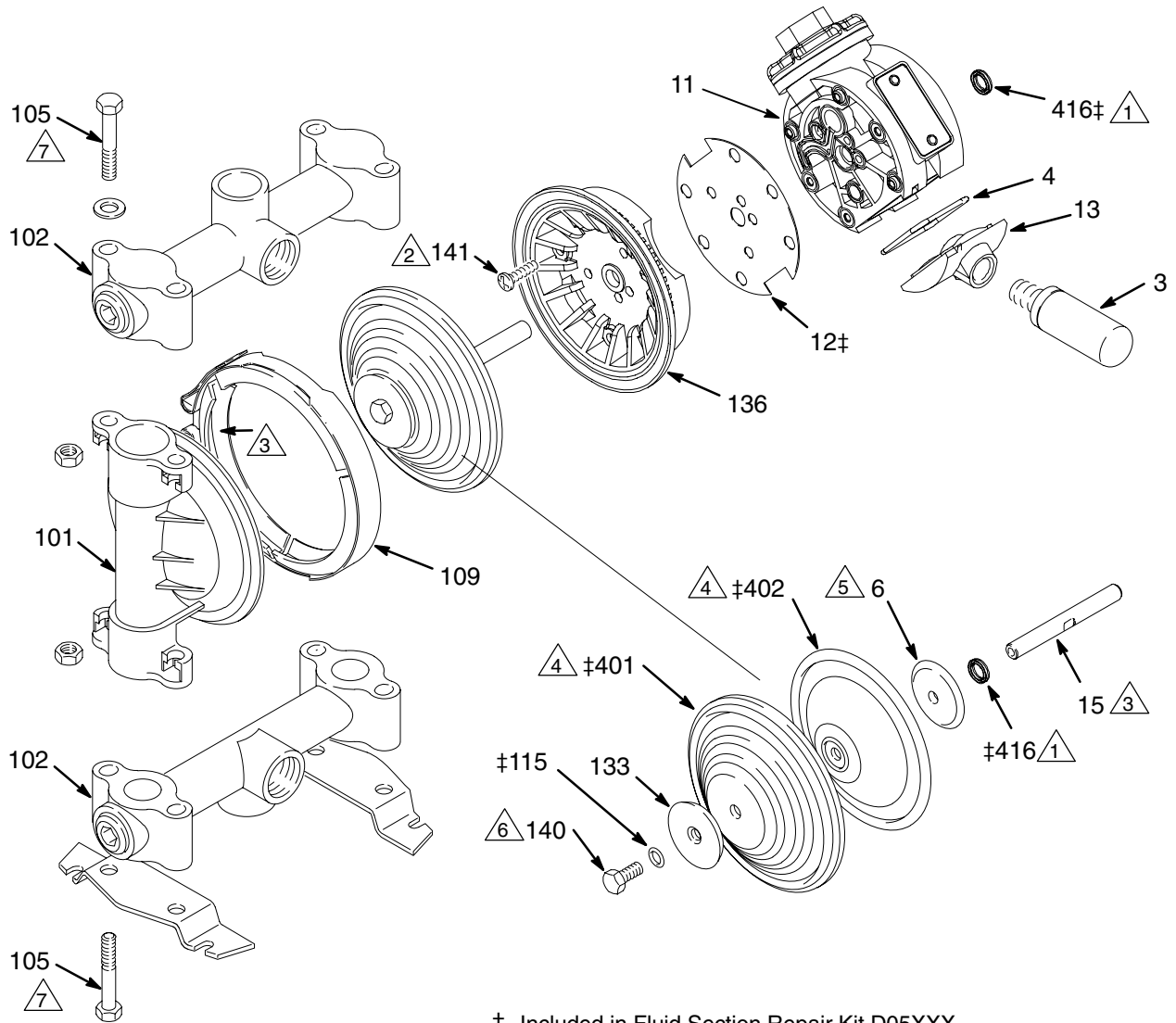

† Included in Fluid Section Repair Kit D05XXX

- 1 Install with lips facing out of center housing (11).
- 2 Torque to 35 to 45 in-lb (4.0 to 5.1 N-m).
- 3 Apply grease.
- 4 The words "AIR SIDE" on diaphragms (and on backup diaphragms used on PTFE models) must face toward diaphragm shaft (15).
- 5 Flat side of the air-side diaphragm plate must face toward diaphragm shaft (15).
- 6 Apply medium-strength (blue) Loctite® or equivalent to threads, and torque to 80 to 90 in-lb (9 to 10 N-m) at 100 rpm maximum.
- 7 Torque to 80 to 90 in-lb (9 to 10 N-m). See **Torque Sequence**, page 27.

Fig. 10

9072A

# Husky 515 and Husky 716 Pump Matrix

Your Model No. is marked on the pump's serial plate. To determine a pump Model No. from the following matrix, select the six digits that describe the pump, working from left to right. The first digit is always **D**, designating Husky diaphragm pumps. The remaining five digits define the air motor type and the materials of construction. For example, a pump with a standard air motor, acetal fluid section, acetal seats, PTFE balls, and PTFE diaphragms is Model **D 5 1 2 1 1**.

Column 1	Column 2	Column 3	Column 4	Column 5	Column 6
<b>Diaphragm Pump</b>	<b>Air Motor</b>	<b>Fluid Section</b>	<b>Guides</b>	<b>Balls</b>	<b>Diaphragms</b>
<b>D</b> (for all pumps)	<b>4</b> (Husky 515/716; remote-operated)	<b>1</b> (acetal) Husky 515, NPT	<b>2</b> (acetal)	<b>1</b> (PTFE)	<b>1</b> (PTFE)
	<b>5</b> (Husky 515/716; standard)	<b>2</b> (polypropylene) Husky 515, NPT	<b>3</b> (316 sst)	<b>3</b> (316 sst)	
		<b>3</b> (aluminum) Husky 716, NPT	<b>9</b> (polypropylene)	<b>5</b> (TPE)	<b>5</b> (TPE)
		<b>4</b> (stainless steel) Husky 716, NPT	<b>A</b> (PVDF)	<b>6</b> (Santoprene®)	<b>6</b> (Santoprene®)
		<b>5</b> (PVDF) Husky 515, NPT	<b>D</b> (duckbill)	<b>7</b> (buna-N)	<b>7</b> (buna-N)
		<b>A</b> (acetal) Husky 515, BSPT		<b>8</b> (fluoroelastomer)	<b>8</b> (fluoroelastomer)
		<b>B</b> (polypropylene) Husky 515, BSPT			
		<b>C</b> (aluminum) Husky 716, BSPT			
		<b>D</b> (stainless steel) Husky 716, BSPT			
	<b>E</b> (PVDF) Husky 515, BSPT				

**Note:** The following models have ports that open downward. See page 21.

- Husky 515: 241564, 241565, and 241484
- Husky 716: 243305, 243306, 243307, and 246485

# Husky 515 and Husky 716 Pumps

## **Model 241564, 515 pump**

Same as the D51211 pump, but with an open downward port.

## **Model 241565, 515 pump**

Same as the D52911 pump, but with an open downward port.

## **Model 248171, 515 pump**

Same as the D51277 pump, except with split inlets/outlets.

## **Model 248172, 515 pump**

Same as the D51255 pump, except with split inlets/outlets.

## **Model 248173, 515 pump**

Same as the D52977 pump, except with split inlets/outlets.

## **Model 248174, 515 pump**

Same as the D52955 pump, except with split inlets/outlets.

## **Model 246484, 515 pump**

Same as the D51331 pump, but with an open downward port. Use inlet manifold 241558.

## **Model 246485, 716 pump**

Same as the D53331 pump, but with an open downward port. Use inlet manifold 190246.

## **Model 243305, 716 pump**

Same as the D53266 pump, but with an open downward port. Use inlet manifold 190246.

## **Model 243306, 716 pump**

Same as the D53277 pump, but with an open downward port. Use inlet manifold 190246.

## **Model 243307, 716 pump**

Same as the D53211 pump, but with an open downward port. Use inlet manifold 190246.

## **Model 257447, 716 pump**

Same as the D54311 pump, but tested for use with moisture-sensitive materials.

## **Model 24B674, 716 pump**

Same as the D54311 pump

# Husky 515 and Husky 716 Repair Kits

**NOTE:** Order Repair Kits separately.

To order the Air Valve Repair Kit, order **Part No. 241657**.

To order the Fluid Section Repair Kit, order **Part No. D05 \_ \_ \_**. For the last three digits, use the last three digits of your pump Model No.

# Husky 515 and Husky 716 Common Parts

See the Pump Matrix on page 20 for an explanation of the **Matrix Column** and the **Digit**.

## Air Motor Parts List (Matrix Column 2)

Digit	Ref. No.	Part No.	Description	Qty
5	1†	114866	PACKING, o-ring	2
	2†	108808	PACKING, u-cup	2
	3	112933	MUFFLER	1
	4†	162942	PACKING, o-ring	2
	6	195025	PLATE, diaphragm, air side	2
	7†	15Y825	PLUNGER, carriage	2
	8†	192595	CARRIAGE	2
	9†	192596	PIN, carriage	2
	10	192597	COVER, valve chamber	1
	11	192602	HOUSING, center	1
	11*	194380	HOUSING, center	1
	12‡	192765	GASKET	2
	13	194247	COVER, exhaust	1
	14†	194269	PLATE, valve	1
	15	192601	SHAFT, diaphragm	1
	16*	115671	CONNECTOR, male	2

## Guide Parts List (Matrix Column 4)

Digit	Ref. No.	Part No.	Description	Qty
2	201†	186691	GUIDE; acetal	4
	202‡	186692	STOP; acetal	4
3	201†	15V281	GUIDE; sst	4
	202‡	15V282	STOP; sst	4
9	201†	186776	GUIDE; polypropylene	4
	202‡	186777	STOP; polypropylene	4
A	201†	192665	GUIDE; PVDF	4
	202‡	192668	STOP; PVDF	4

D	201†	192138	SPACER	4
	202‡	192137	VALVE, duckbill	4

## Ball Parts List (Matrix Column 5)

Digit	Ref. No.	Part No.	Description	Qty
1	301†	108639	BALL; PTFE	4
3	301†	103462	BALL; sst	4
5	301†	112945	BALL; TPE	4
6	301†	112946	BALL; Santoprene®	4
7	301†	108944	BALL; buna-N	4
8	301†	112959	BALL; fluoroelastomer	4

## Diaphragm Parts List (Matrix Column 6)

Digit	Ref. No.	Part No.	Description	Qty
1	416†	108808	PACKING, u-cup	2
	401†	108839	DIAPHRAGM; PTFE	2
	402‡	183542	DIAPHRAGM, backup; polyurethane	2
5	416†	108808	PACKING, u-cup	2
	401†	189537	DIAPHRAGM; TPE	2
6	416†	108808	PACKING, u-cup	2
	401†	189536	DIAPHRAGM; Santoprene®	2
7	416†	108808	PACKING, u-cup	2
	401†	190148	DIAPHRAGM; buna-N	2
8	416†	108808	PACKING, u-cup	2
	401†	190149	DIAPHRAGM; fluoroelastomer	2

† Included in Air Valve Repair Kit 241657

‡ Included in Fluid Section Repair Kit D05XXX

\* These parts are unique to the remote operated air motor.

# Husky 515 Parts Drawing

† Included in Air Valve Repair Kit 241657

‡ Included in Fluid Section Repair Kit D05XXX

\* These parts are unique to the remote operated air motor.

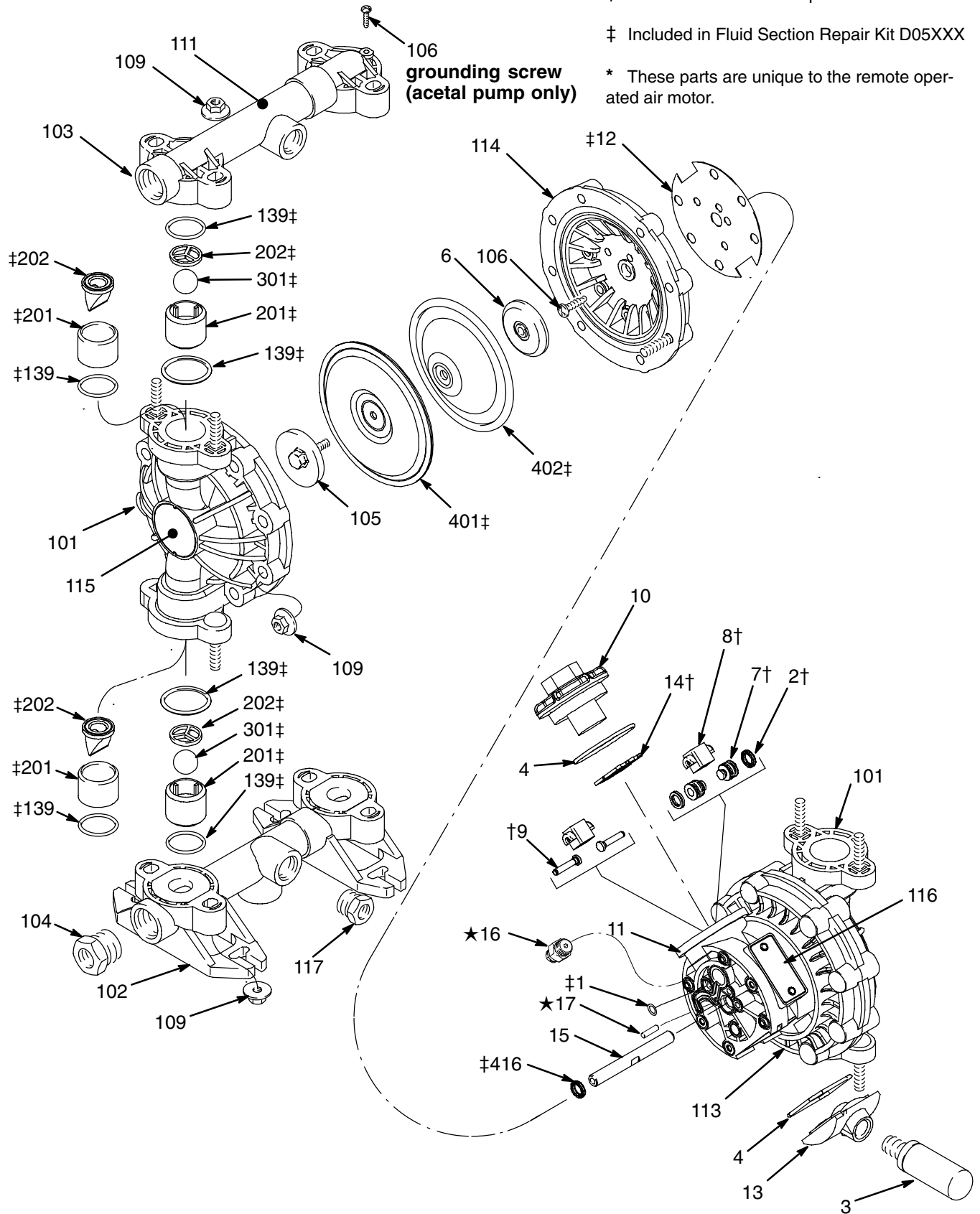

9064B

# Husky 515 Fluid Section Parts List

See the Pump Matrix on page 20 for an explanation of the **Matrix Column** and the **Digit**.

See page 22 for Air Motor Parts List (Matrix Column 2)

## Husky 515 Fluid Section Parts List (Matrix Column 3)

Ref. No.	Acetal Pumps Digit: 1 (NPT) Digit: A (BSPT)			Polypropylene Pumps Digit: 2 (NPT) Digit: B (BSPT)			PVDF Pumps Digit: 5 (NPT) Digit: E (BSPT)		
	Part No.	Description	Qty	Part No.	Description	Qty	Part No.	Description	Qty
101	192559	COVER, fluid; acetal	2	192558	COVER, fluid; polypropylene	2	192560	COVER, fluid; PVDF	2
102	192571	MANIFOLD, inlet; acetal; NPT	1	192570	MANIFOLD, inlet; polypropylene; NPT	1	192572	MANIFOLD, inlet; PVDF; NPT	1
102	192576	MANIFOLD, inlet; acetal; BSPT	1	192575	MANIFOLD, inlet; polypropylene; BSPT	1	192577	MANIFOLD, inlet; PVDF; BSPT	1
102*	241558	MANIFOLD, inlet; open downspout, acetal; NPT	1	241557	MANIFOLD, inlet; open downspout, polypropylene; NPT	1		Not applicable to PVDF pumps	
103	192562	MANIFOLD, outlet; acetal; NPT	1	192561	MANIFOLD, outlet; polypropylene; NPT	1	192563	MANIFOLD, outlet; PVDF; NPT	1
103	192567	MANIFOLD, outlet; acetal; BSPT	1	192566	MANIFOLD, outlet; polypropylene; BSPT	1	192568	MANIFOLD, outlet; PVDF; BSPT	1
104	194362	PLUG; acetal; 3/4 NPT	2	194361	PLUG; polypropylene; 3/4 NPT	2	194363	PLUG; PVDF; 3/4 NPT	2
104	194368	PLUG; acetal; 3/4 BSPT	2	194367	PLUG; polypropylene; 3/4 BSPT	2	194369	PLUG; PVDF; 3/4 BSPT	2
105	187711	PLATE, diaphragm, fluid; acetal	2	187712	PLATE, diaphragm, fluid; polypropylene	2	192679	PLATE, diaphragm, fluid; PVDF	2
106	114882	SCREW, torx	13	114882	SCREW, torx	12	114882	SCREW, torx	12
109	114850	NUT, hex, large flng	24	114850	NUT, hex, large flng	24	114850	NUT, hex, large flng	24
111	187732	LABEL, warning	1	187732	LABEL, warning	1	187732	LABEL, warning	1
113	192599	COVER, air, right	1	192599	COVER, air, right	1	192599	COVER, air, right	1
114	192600	COVER, air, left	1	192600	COVER, air, left	1	192600	COVER, air, left	1
115	194352	LABEL, identification	2	194352	LABEL, identification	2	194352	LABEL, identification	2
116	290045	PLATE, designation	1	290045	PLATE, designation	1	290045	PLATE, designation	1
117	194359	PLUG; acetal; 1/2 NPT	2	194358	PLUG; polypropylene; 1/2 NPT	2	194360	PLUG; PVDF; 1/2 NPT	2
117	194365	PLUG, acetal; 1/2 BSPT	2	194364	PLUG; polypropylene; 1/2 BSPT	2	194366	PLUG; PVDF; 1/2 BSPT	2
119	111183	RIVET (for plate 116)	2	111183	RIVET (for plate 116)	2	111183	RIVET (for plate 116)	2
139 ‡	114849	PACKING, o-ring; encapsulated	8	114849	PACKING, o-ring; encapsulated	8	114849	PACKING, o-ring; encapsulated	8

\* Inlet manifolds with downspouts are used on pump models 241564, 241565, and 246484 only.

# Husky 716 Parts Drawing

† Included in Air Valve Repair Kit 241657

‡ Included in Fluid Section Repair Kit D05XXX

\* These parts are unique to the remote operated air motor.

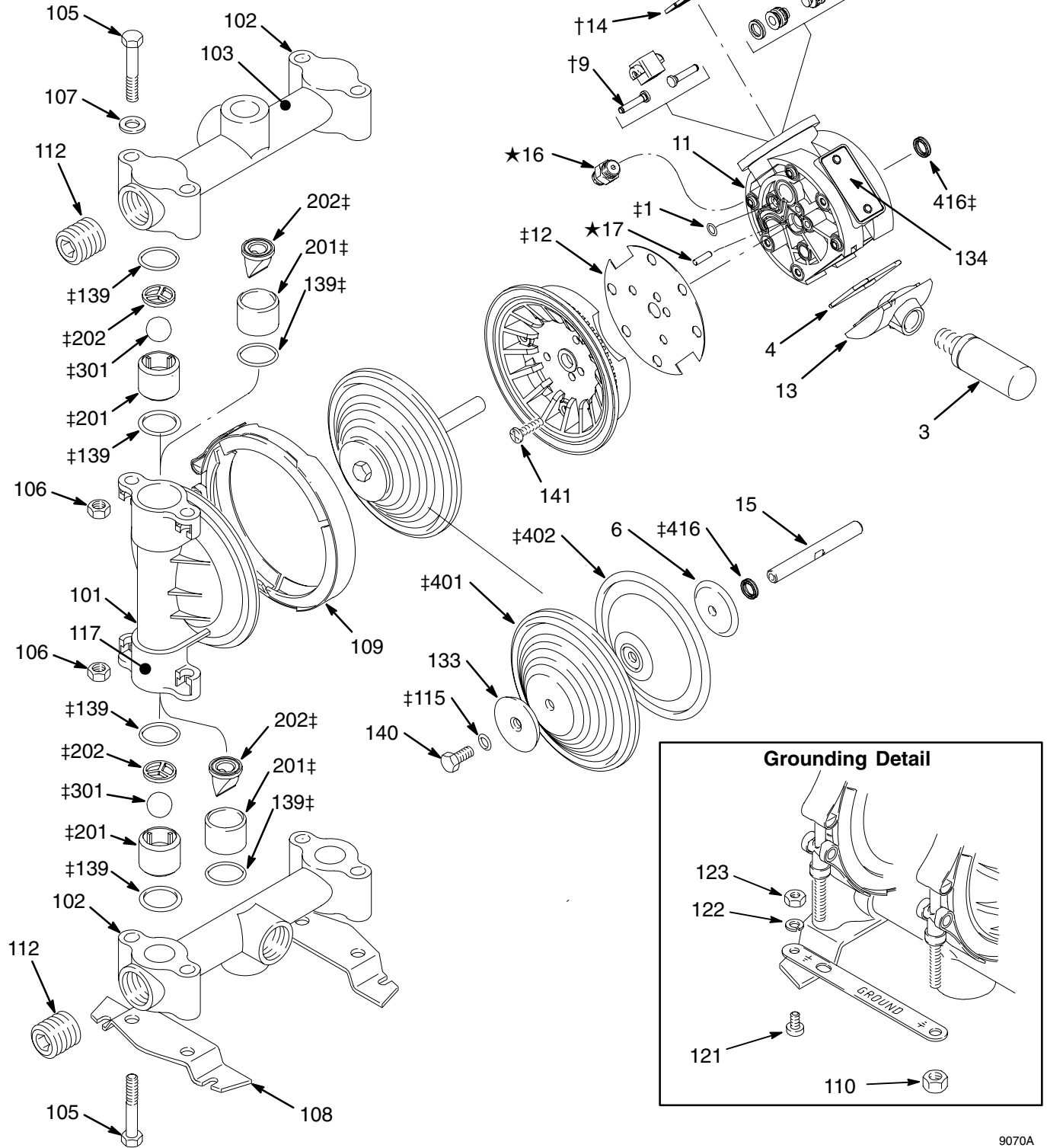

9070A

# Husky 716 Fluid Section Parts List

See the Pump Matrix on page 20 for an explanation of the **Matrix Column** and the **Digit**.

See page 22 for Air Motor Parts List (Matrix Column 2)

## Husky 716 Fluid Section Parts List (Matrix Column 3)

Ref. No.	Aluminum Pumps Digit: 3 (NPT) Digit: C (BSPT)			Stainless Steel (sst) Pumps Digit: 4 (NPT) Digit: D (BSPT)		
	Part No.	Description	Qty	Part No.	Description	Qty
101	185622	COVER, fluid; aluminum	2	187241	COVER, fluid; sst	2
102*	185624	MANIFOLD; aluminum; NPT	2	187244	MANIFOLD; sst	2
102	192061	MANIFOLD; aluminum; BSPT	2	192060	MANIFOLD; sst; BSPT	2
102	190246	MANIFOLD; aluminum; NPT	2			
103	189220	LABEL, warning	1	189220	LABEL, warning	1
105	112912	SCREW; 3/8-16; 2.25 in. (57.2 mm)	8	112912	SCREW; 3/8-16; 2.25 in. (57.2 mm)	8
106	112913	NUT, hex; 3/8-16; sst	8	112913	NUT, hex; 3/8-16; sst	8
107	112914	WASHER, flat; 3/8 in.; sst	4	112914	WASHER, flat; 3/8 in.; sst	4
108	186207	BASE, feet	2	186207	BASE, feet	2
109	189540	CLAMP, vee	2	189540	CLAMP, vee	2
110	112499	NUT, clamp; 1/4-28	2	112499	NUT, clamp; 1/4-28	2
111	191079	STRIP, grounding	1	191079	STRIP, grounding	1
112	102726	PLUG, steel; NPT	2	111384	PLUG; sst; NPT	2
112	113989	PLUG, steel; BSPT	2	113990	PLUG; sst; BSPT	2
115‡	110004	O-RING; PTFE	2	110004	O-RING; PTFE	2
117	186205	LABEL, warning	1			
121	102790	SCREW; 10-24; 0.31 in. (8 mm)	1	102790	SCREW; 10-24; 0.31 in. (8 mm)	1
122	100718	LOCKWASHER; #10	1	100718	LOCKWASHER; #10	1
123	100179	NUT, hex; 10-24	1	100179	NUT, hex; 10-24	1
133	191837	PLATE, diaphragm, fluid side; sst	2	191837	PLATE, diaphragm, fluid side; sst	2
134	290045	PLATE, designation	1	290045	PLATE, designation	1
136	194246	COVER air	2	194246	COVER air	2
139‡	110636	O-RING; PTFE	8	110636	O-RING; PTFE	8
140	113747	SCREW, flange; hex head	2	113747	SCREW, flange; hex head	2
141	114882	SCREW, machine, torx	12	114882	SCREW, machine, torx	12
142	111183	RIVET (for plate 134)	2	111183	RIVET (for plate 134)	2

‡ Included in Fluid Section Repair Kit D05XXX

\*Pump model numbers 243305, 243306, 243307, and 246485 have one 190246 inlet manifold and one 185624 outlet manifold.

# Torque Sequence

Always follow torque sequence when instructed to torque fasteners.

## Husky 515

1. Left/Right Fluid Covers  
Torque bolts to 80–90 in–lb (9–10 N•m)

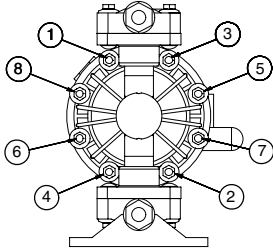

SIDE VIEW

2. Inlet Manifold  
Torque bolts to 80–90 in–lb (9–10 N•m)

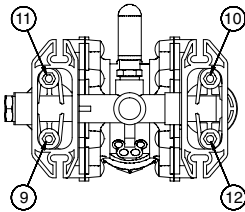

BOTTOM VIEW

3. Outlet Manifold  
Torque bolts to 80–90 in–lb (9–10 N•m)

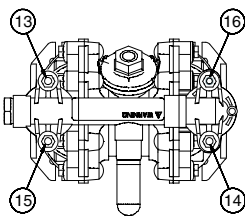

TOP VIEW

## Husky 716

1. Left/Right Fluid Covers  
Torque bolts to 80–90 in–lb (9–10 N•m)

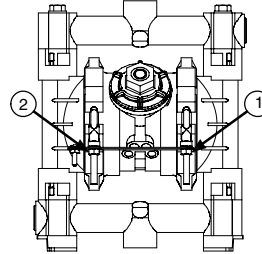

FRONT VIEW

2. Inlet Manifold  
Torque bolts to 80–90 in–lb (9–10 N•m)

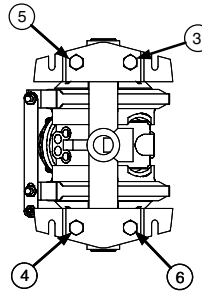

BOTTOM VIEW

3. Outlet Manifold  
Torque Bolts to 80–90 in–lb (9–10 N•m)

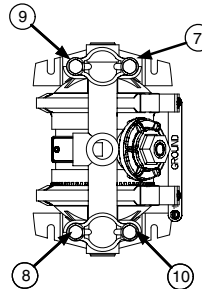

TOP VIEW

# Husky 515 Technical Data

Maximum fluid working pressure .....	100 psi (0.7 MPa, 7 bar)
Air pressure operating range .....	30 to 100 psi (0.2 to 0.7 MPa, 2.1 to 7 bar )
Operating Temperature Range*	
Minimum (all pumps) .....	40°F (4°C)
Maximum	
Acetal: .....	180°F (82°C)
Polypropylene: .....	150°F (66°C)
Aluminum, stainless steel, PVDF: .....	225°F (107°C)
Maximum air consumption .....	28 scfm (0.672 cubic meters/min.)
Maximum free flow delivery (1/2 in. ports) .....	15 gpm (57 l/min)
Maximum pump speed .....	400 cpm
Gallons (Liters) per cycle .....	0.04 (0.15)
Maximum suction lift (water w/buna balls) .....	15 ft (4.5 m) dry, 25 ft (7.6 m) wet
Maximum size pumpable solids .....	3/32 in. (2.5 mm)
Sound power level (measured per ISO standard 9614-2)	
At 70 psig (0.48 MPa, 4.8 bar) at 50 cycles per minute .....	77 dBa
At 100 psig (0.7 MPa, 7 bar) at maximum cycles per minute .....	95 dBa
Sound pressure level (measured 1 meter from pump)	
At 70 psig (0.48 MPa, 4.8 bar) at 50 cycles per minute .....	67 dBa
At 100 psig (0.7 MPa, 7 bar) at maximum cycles per minute .....	85 dBa
Air inlet size .....	1/4 npt(f)
Air exhaust port size .....	3/8 npt(f)
Fluid inlet size. ....	1/2 and 3/4 in. npt(f) or bspt(f)
Fluid outlet size. ....	1/2 and 3/4 in. npt(f) or bspt(f)
Wetted parts (in addition to ball, seat, and diaphragm materials, which vary by pump)	
Polypropylene pumps .....	polypropylene, PTFE
Acetal pumps .....	groundable acetal, PTFE
PVDF pumps .....	PVDF, PTFE
Non-wetted external parts .....	polypropylene, stainless steel, polyester and aluminum (labels), nickel-plated brass
Weight (approximate)	
Polypropylene pumps .....	6.5 lb (2.9 kg)
Acetal pumps .....	7.8 lb (3.5 kg)
PVDF pumps .....	8.5 lb (3.9 kg)

*\*These temperatures are based on mechanical stress only and may be altered significantly by pumping certain chemicals. Consult engineering guides for chemical compatibilities and temperature limits, or contact your Graco distributor.*

*Santoprene® is a registered trademark of the Monsanto Company.*

*Loctite® is a registered trademark of the Loctite Corporation.*

# Husky 515 Dimensions

\* Pumps with duckbill check valves are shipped with the inlet manifold on top and the outlet manifold on the bottom. To make the inlet manifold on the bottom and the outlet manifold on the top, rotate each of the four duckbill assemblies vertically 180° as shown below.

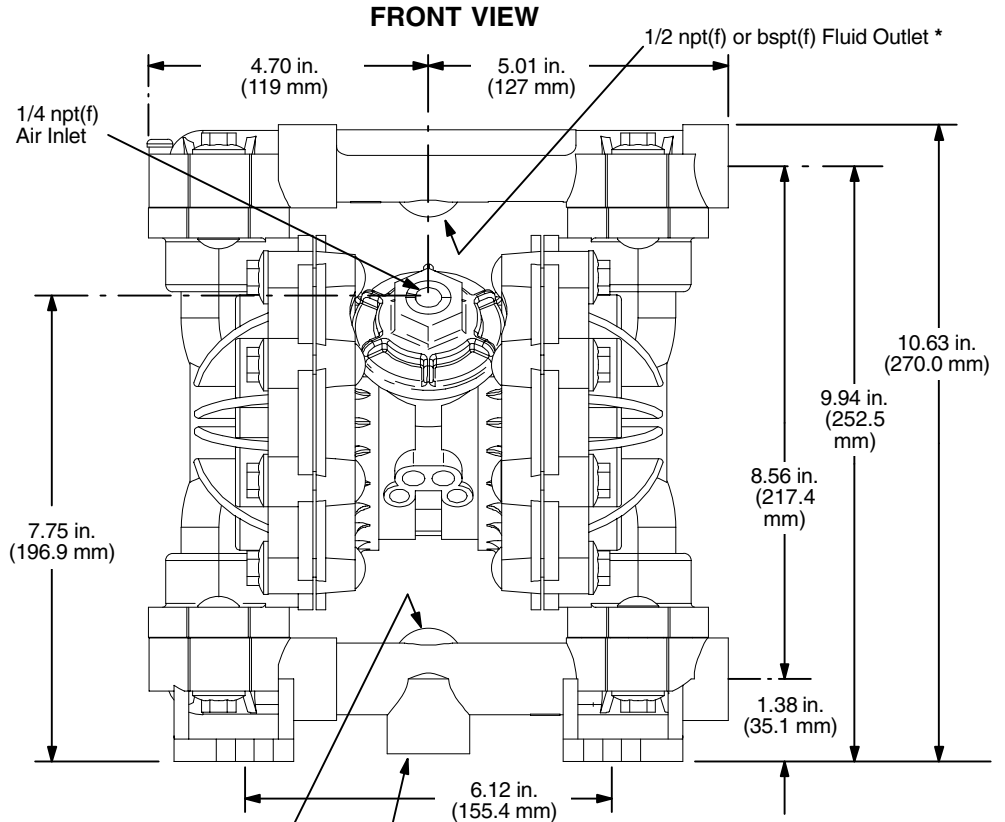

## SIDE VIEW

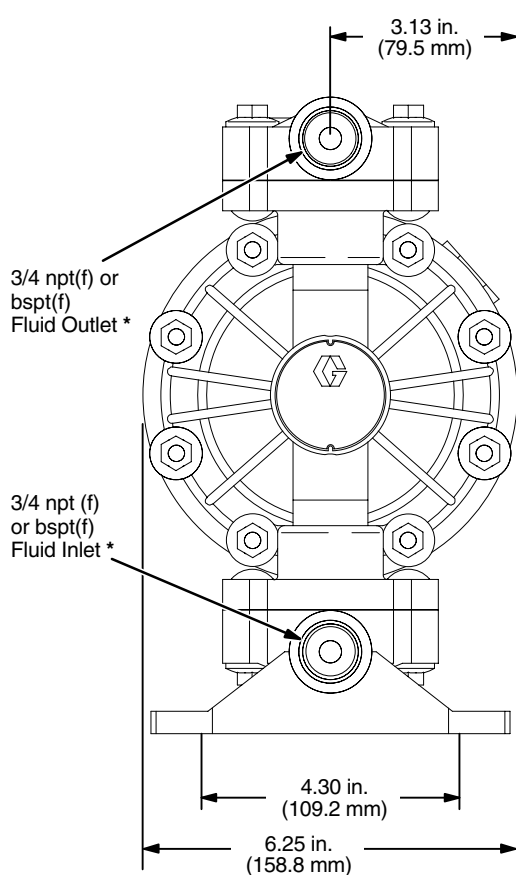

1/2 npt(f) or bspt(f) Fluid Inlet \*

3/4 npt(f) or bspt(f) Fluid Inlet \*

Note: Bottom port open on 241564, 241565, and 246484 only.

## PUMP MOUNTING HOLE PATTERN

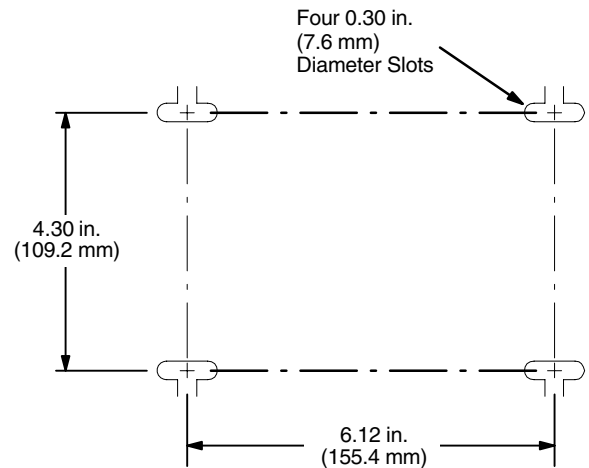

9077A

# Husky 716 Technical Data

Maximum fluid working pressure .....	100 psi (0.7 MPa, 7 bar)
Air pressure operating range .....	30 to 100 psi (0.2 to 0.7 MPa, 2.1 to 7 bar)
Operating Temperature Range*	
Minimum (all pumps) .....	40°F (4°C)
Maximum	
Acetal: .....	180°F (82°C)
Polypropylene: .....	150°F (66°C)
Aluminum, stainless steel, PVDF: .....	225°F (107°C)
Maximum air consumption .....	28 scfm (0.672 cubic meters/min.)
Maximum free flow delivery .....	16 gpm (61 l/min)
Maximum pump speed .....	400 cpm
Gallons (Liters) per cycle .....	0.04(0.15)
Maximum suction lift (water w/buna balls) .....	15 ft (4.5 m) dry, 25 ft (7.6 m) wet
Maximum size pumpable solids .....	3/32 in. (2.5 mm)
Sound power level (measured per ISO standard 9614-2)	
At 70 psig (0.48 MPa, 4.8 bar) at 50 cycles per minute .....	77 dBa
At 100 psig (0.7 MPa, 7 bar) at maximum cycles per minute .....	95 dBa
Sound pressure level (measured 1 meter from pump)	
At 70 psig (0.48 MPa, 4.8 bar) at 50 cycles per minute .....	67 dBa
At 100 psig (0.7 MPa, 7 bar) at maximum cycles per minute .....	85 dBa
Air inlet size .....	1/4 npt(f)
Air exhaust port size .....	3/8 npt(f)
Fluid inlet size .....	3/4 npt(f) or bspt(f)
Fluid outlet size .....	3/4 npt(f) or bspt(f)
Wetted parts (in addition to ball, seat, and diaphragm materials, which vary by pump)	
Aluminum pumps .....	aluminum, stainless steel, PTFE, zinc-plated steel
Stainless steel pumps .....	316 stainless steel, PTFE
Non-wetted external parts .....	polypropylene, stainless steel, polyester (labels), nickel-plated brass, epoxy-coated steel (feet)
Weight (approximate)	
Aluminum pumps .....	8.5 lb (3.9 kg)
Stainless steel pumps .....	18 lb (8.2 kg)

*\*These temperatures are based on mechanical stress only and may be altered significantly by pumping certain chemicals. Consult engineering guides for chemical compatibilities and temperature limits, or contact your Graco distributor.*

*Santoprene® is a registered trademark of the Monsanto Company.*

*Loctite® is a registered trademark of the Loctite Corporation.*

# Husky 716 Dimensions

\* Pumps with duckbill check valves are shipped with the inlet manifold on top and the outlet manifold on the bottom. To make the inlet manifold on the bottom and the outlet manifold on the top, rotate each of the four duckbill assemblies vertically 180° as shown below.

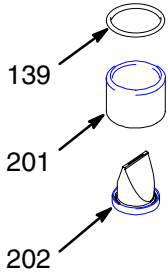

## FRONT VIEW

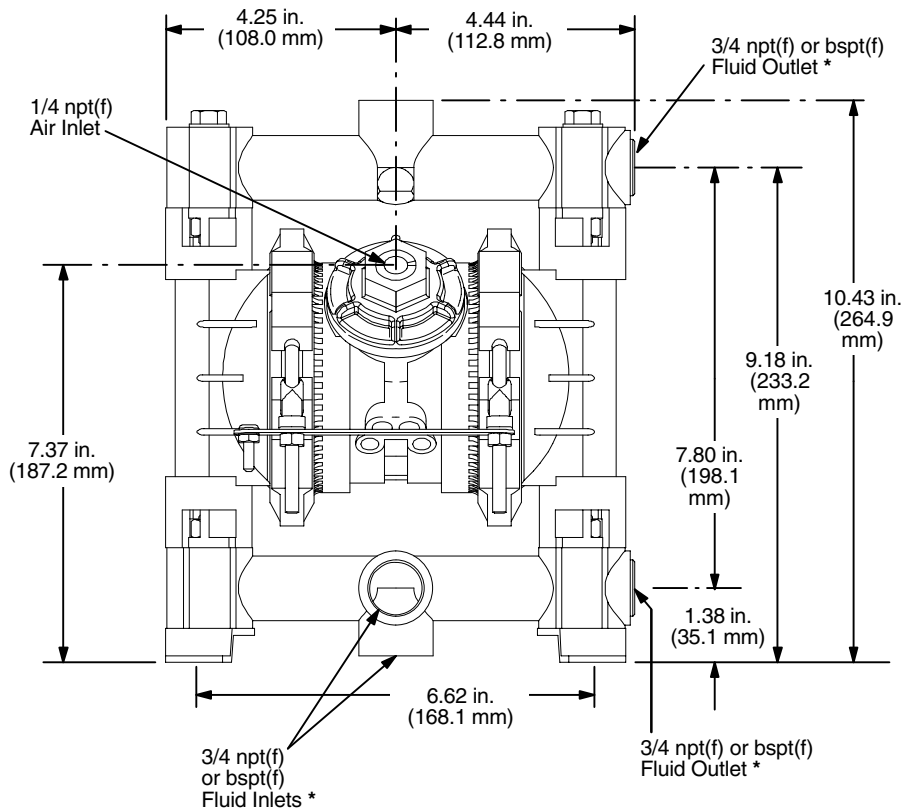

Note: Bottom port open on 243305, 243306, 243307, and 246485 only.

## SIDE VIEW

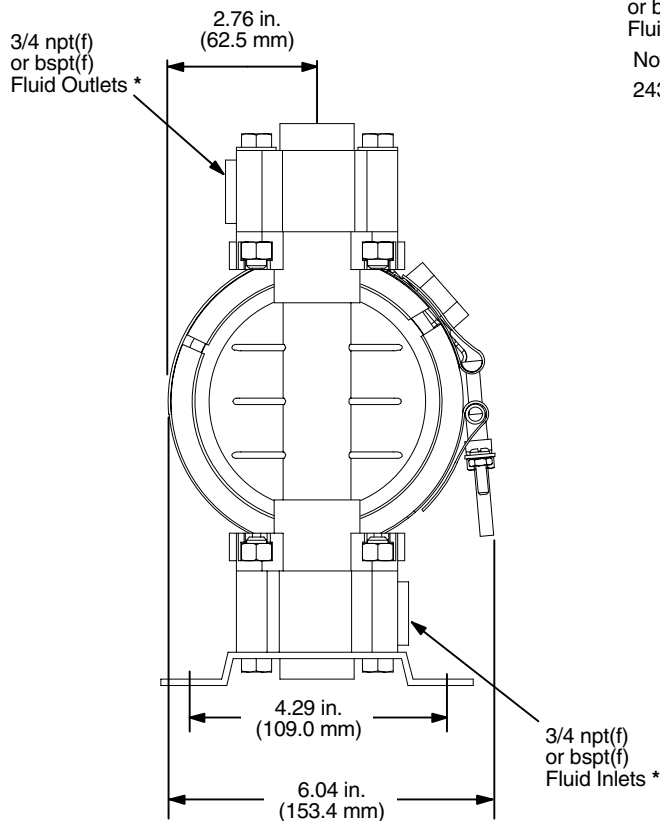

## PUMP MOUNTING HOLE PATTERN

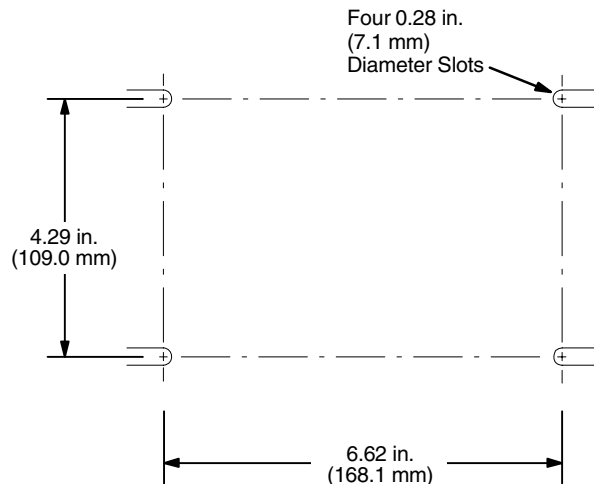

9078A

# Husky 515 and 716 Performance Charts

## Fluid Outlet Pressure

Test Conditions: Pump tested in water with inlet submerged.

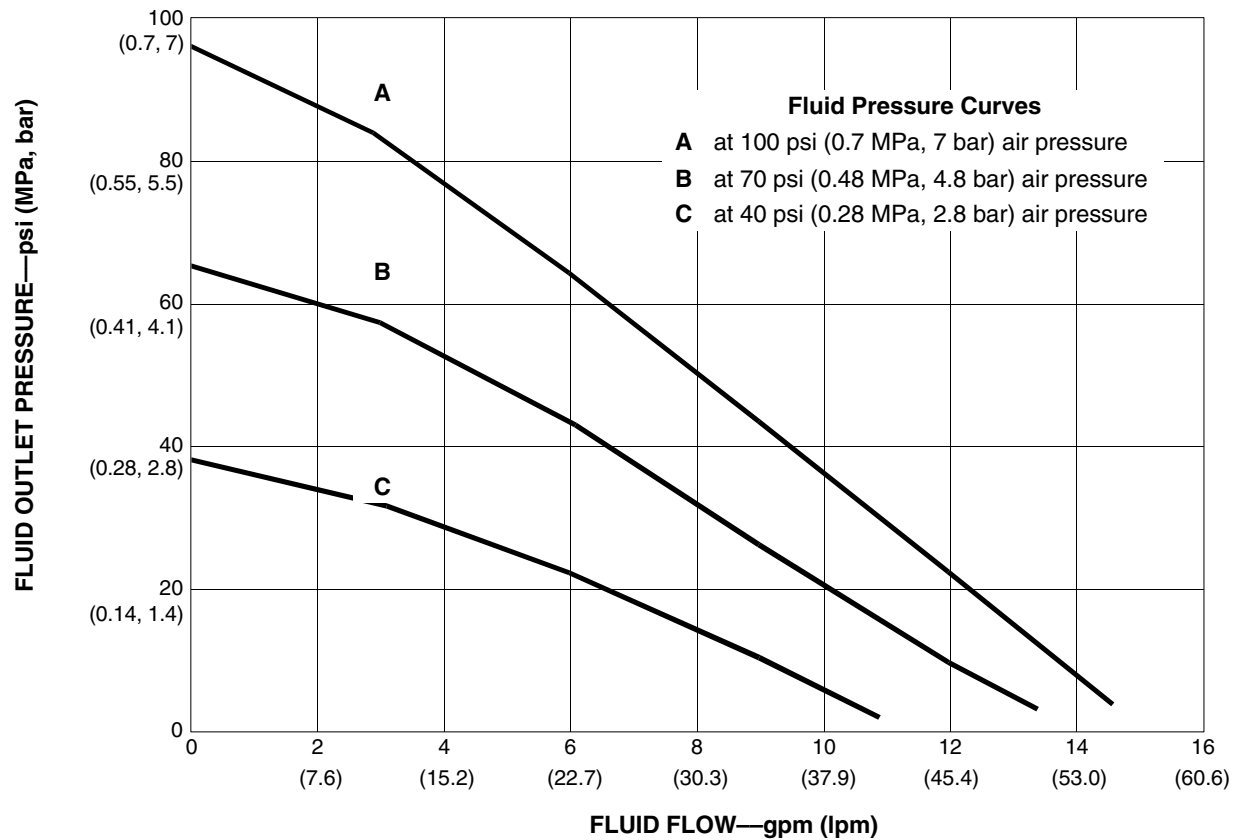

To find Fluid Outlet Pressure (psi/MPa/bar) at a specific fluid flow (gpm/lpm) and operating air pressure (psi/MPa/bar):

1. Locate fluid flow rate along bottom of chart.
2. Follow vertical line up to intersection with selected fluid outlet pressure curve.
3. Follow left to scale to read fluid outlet pressure.

# Husky 515 and 716 Performance Charts

## Air Consumption

**Test Conditions:** Pump tested in water with inlet submerged.

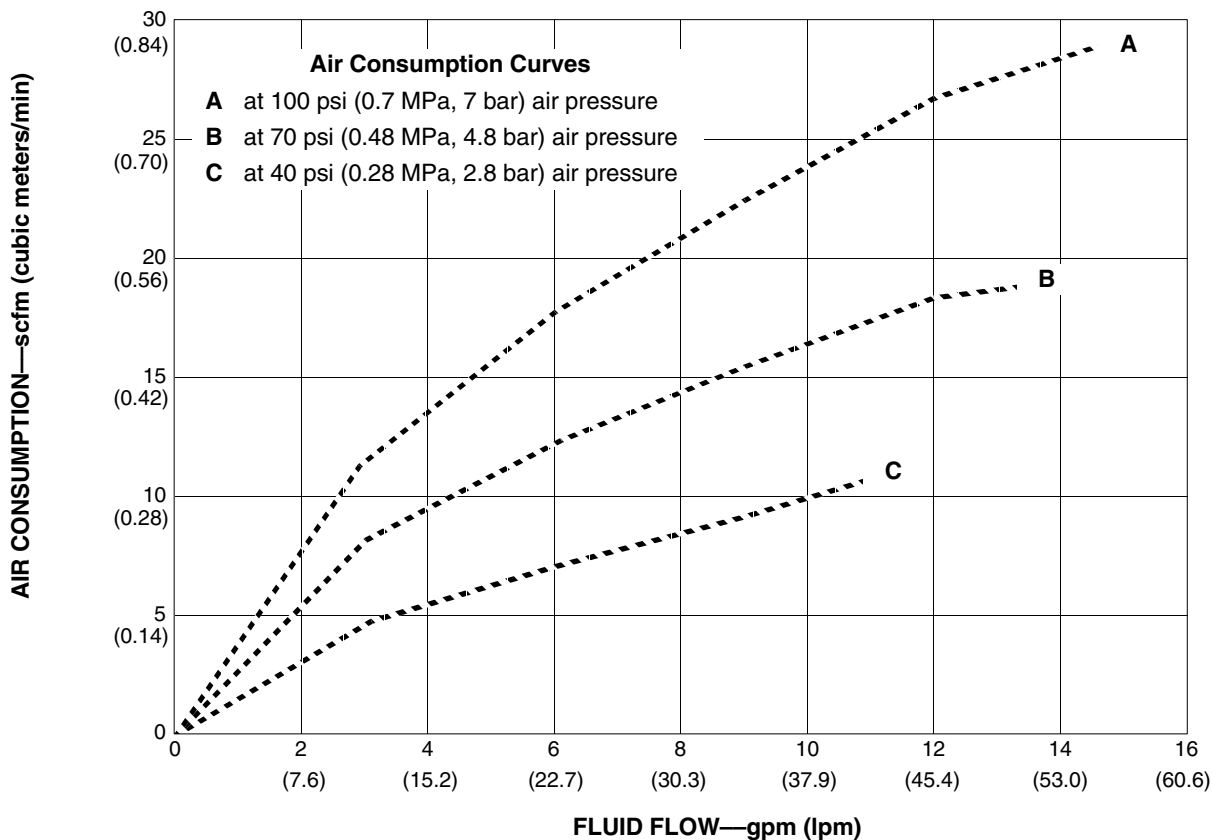

**To find Pump Air Consumption** (scfm or m<sup>3</sup>/min) at a specific fluid flow (gpm/lpm) and air pressure (psi/MPa/bar):

1. Locate fluid flow rate along bottom of chart.
2. Read vertical line up to intersection with selected air consumption curve.
3. Follow left to scale to read air consumption.