

Instructions – Parts List



ACETAL, POLYPROPYLENE, AND PVDF

Husky™ 1040 Air-Operated Diaphragm Pumps

308443Z2

Acetal Model Shown

See Models on page 2 for a list of pump models and descriptions.

120 psi (0.8 MPa, 8 bar) Maximum Fluid Working Pressure
120 psi (0.8 MPa, 8 bar) Maximum Air Input Pressure



Important Safety Instructions

Read all warnings and instructions in this manual. Save these instructions.

Patent No.
CN ZL94102643.4
FR 9408894
JA 3517270
US 5,368,452

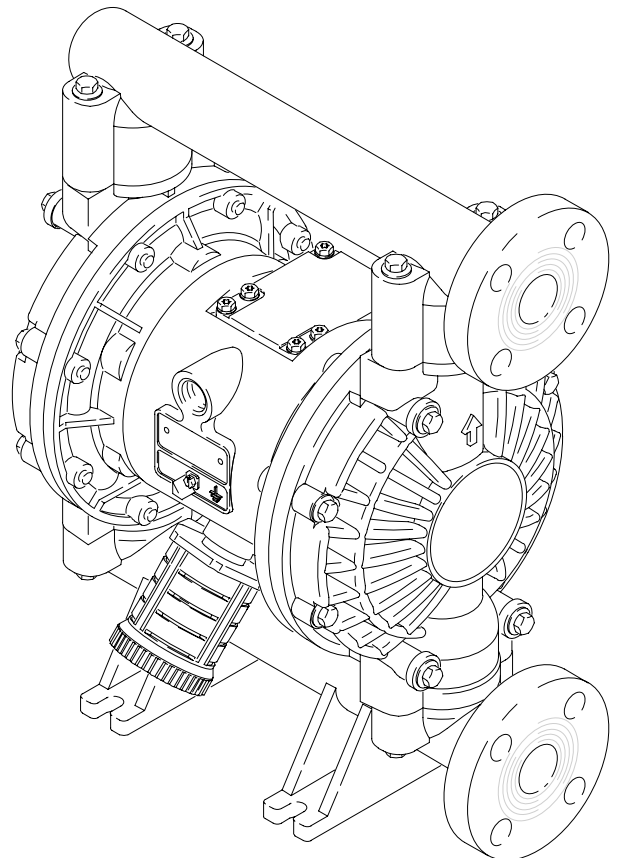

04155B

PROVEN QUALITY. LEADING TECHNOLOGY.



HO03

Table of Contents

Models	2	Repair Kit Matrix	25
Safety Warnings	3	Parts	26
Installation	5	Torque Sequence	30
Operation	12	Dimensional Drawings	31
Maintenance	13	Technical Data and Performance Chart	32
Troubleshooting	14	Graco Standard Warranty	34
Service		Graco Information	34
Repairing the Air Valve	16		
Ball Check Valve Repair	18		
Diaphragm Repair	19		
Bearing and Air Gasket Removal	22		
Pump Matrix	24		

Models

Model No.	Description
*D71_____	Acetal Pumps (see certification note below)
*D81_____	Acetal Pumps, Remote (see certification note below)
*D72_____	Polypropylene Pumps
*D82_____	Polypropylene Pumps, Remote
*D75_____	PVDF Pumps
*D85_____	PVDF Pumps, Remote
*DR2_____	Polypropylene Plus Pumps
*DS2_____	Polypropylene Plus Pumps, Remote
*DR5_____	PVDF Plus Pumps
*DS5_____	PVDF Plus Pumps, Remote
24B754	PVDF Plus Pump with overmolded diaphragms
24B755	Polypropylene Plus Pump with overmolded diaphragms
24B756	Polypropylene Pump with overmolded diaphragms
24B757	Polypropylene Pump with overmolded diaphragms and sst seats
24B831	PVDF Pump with overmolded diaphragms

***NOTE:** Refer to the Pump Matrix on page 24 to determine the Model No. of your pump.

NOTE: Plus Models include stainless steel center sections.

CERTIFICATION NOTE: Acetal Pump Models D71_____ and D81_____ are  II 2 GD c IIC T4 certified.

Symbols

Warning Symbol



This symbol alerts you to the possibility of serious injury or death if you do not follow the instructions.

Caution Symbol



This symbol alerts you to the possibility of damage to or destruction of equipment if you do not follow the instructions.

! WARNING



INSTRUCTIONS

EQUIPMENT MISUSE HAZARD

Equipment misuse can cause the equipment to rupture or malfunction and result in serious injury.

- This equipment is for professional use only.
- Read all instruction manuals, tags, and labels before operating the equipment.
- Use the equipment only for its intended purpose. If you are not sure, call your Graco distributor.
- Do not alter or modify this equipment. Use only genuine Graco parts and accessories.
- Check equipment daily. Repair or replace worn or damaged parts immediately.
- Do not exceed the maximum working pressure of the lowest rated component in your system. This equipment has a **120 psi (0.8 MPa, 8 bar) maximum working pressure at 120 psi (0.8 MPa, 8 bar) maximum incoming air pressure.**
- Use fluids and solvents which are compatible with the equipment wetted parts. Refer to the **Technical Data** section of all equipment manuals. Read the fluid and solvent manufacturer's warnings.
- Do not use hoses to pull equipment.
- Route hoses away from traffic areas, sharp edges, moving parts, and hot surfaces. Do not expose Graco hoses to temperatures above 82°C (180°F) or below -40°C (-40°F).
- Do not lift pressurized equipment.
- Comply with all applicable local, state, and national fire, electrical, and safety regulations.

⚠ WARNING



TOXIC FLUID HAZARD

Hazardous fluid or toxic fumes can cause serious injury or death if splashed in the eyes or on the skin, inhaled, or swallowed.

- Know the specific hazards of the fluid you are using.
- Store hazardous fluid in an approved container. Dispose of hazardous fluid according to all local, state and national guidelines.
- Always wear protective eyewear, gloves, clothing and respirator as recommended by the fluid and solvent manufacturer.
- Pipe and dispose of the exhaust air safely, away from people, animals, and food handling areas. If the diaphragm fails, the fluid is exhausted along with the air. See **Air Exhaust Ventilation** on page 11.
- To pump acids, **always** use a PVDF or a polypropylene pump. Take precautions to avoid acid or acid fumes from contacting the pump housing exterior. Stainless steel parts will be damaged by exposure to acid spills and fumes. **Never** use an acetal pump to pump acids.



FIRE AND EXPLOSION HAZARD

Improper grounding, poor ventilation, open flames or sparks can cause a hazardous condition and result in a fire or explosion and serious injury.

- Ground the equipment. Refer to **Grounding** on page 6.
- **Never** use a polypropylene or PVDF pump with non-conductive flammable fluids as specified by your local fire protection code. Refer to **Grounding** on page 6 for additional information. Consult your fluid supplier to determine the conductivity or resistivity of your fluid.
- If there is any static sparking or you feel an electric shock while using this equipment, **stop pumping immediately**. Do not use the equipment until you identify and correct the problem.
- Provide fresh air ventilation to avoid the buildup of flammable fumes from solvents or the fluid being pumped.
- Pipe and dispose of the exhaust air safely, away from all sources of ignition. If the diaphragm fails, the fluid is exhausted along with the air. See **Air Exhaust Ventilation** on page 11.
- Keep the work area free of debris, including solvent, rags, and gasoline.
- Electrically disconnect all equipment in the work area.
- Extinguish all open flames or pilot lights in the work area.
- Do not smoke in the work area.
- Do not turn on or off any light switch in the work area while operating or if fumes are present.
- Do not operate a gasoline engine in the work area.

Installation

General Information

- The Typical Installation shown in Fig. 2 is only a guide for selecting and installing system components. Contact your Graco distributor for assistance in planning a system to suit your needs.
- Always use Genuine Graco Parts and Accessories.
- Reference numbers and letters in parentheses refer to the callouts in the figures and the parts lists on pages 26 to 27.

Tightening Screws Before First Use

Before using the pump for the first time, check and retorque all external fasteners. See **Torque Sequence**, page 30. After the first day of operation, retorque the fasteners. Although pump use varies, a general guideline is to retorque fasteners every two months.

 **WARNING**

 **TOXIC FLUID HAZARD**
Hazardous fluid or toxic fumes can cause serious injury or death if splashed in the eyes or on the skin, inhaled, or swallowed.

- Read **TOXIC FLUID HAZARD** on page 4.
- Use fluids and solvents that are compatible with the equipment wetted parts. Refer to the **Technical Data** section of all equipment manuals. Read the fluid and solvent manufacturer's warnings.

Installation

Grounding

WARNING



FIRE AND EXPLOSION HAZARD

This pump must be grounded. Before operating the pump, ground the system as explained below. Also read the section **FIRE AND EXPLOSION HAZARD** on page 4.



The *acetal pump* contains stainless steel fibers which make the wetted parts conductive. Attaching the ground wire to the grounding screw will ground the air motor and the wetted parts.

The *polypropylene and PVDF pumps* are **not** conductive. Attaching the ground wire to the grounding screw will ground only the air motor. When pumping conductive flammable fluids, **always** ground the entire fluid system by making sure the fluid system has an electrical path to a true earth ground (see Fig. 2). **Never** use a polypropylene or PVDF pump with non-conductive flammable fluids as specified by your local fire protection code.

US Code (NFPA 77 Static Electricity) recommends a conductivity greater than 50×10^{-12} Siemens/meter (mhos/meter) over your operating temperature range to reduce the hazard of fire. Consult your fluid supplier to determine the conductivity or resistivity of your fluid. The resistivity must be less than 2×10^{12} ohm-centimeters.

To reduce the risk of static sparking, ground the pump and all other equipment used or located in the pumping area. Check your local electrical code for detailed grounding instructions for your area and type of equipment.

Ground all of this equipment:

- *Pump:* Connect a ground wire and clamp as shown in Fig. 1. Loosen the grounding screw (W). Insert one end of a 12 ga (1.5 mm²) minimum ground wire (Y) behind the grounding screw and tighten the screw securely. Connect the clamp end of the ground wire to a true earth ground. Order Part No. 222011 Ground Wire and Clamp.

NOTE: When pumping conductive flammable fluids with a polypropylene or PVDF pump, **always** ground the entire fluid system. See the **WARNING** left. Fig. 2 shows a recommended method of grounding flammable fluid containers during filling. This is only a guide; contact your Graco distributor for assistance in grounding your system.

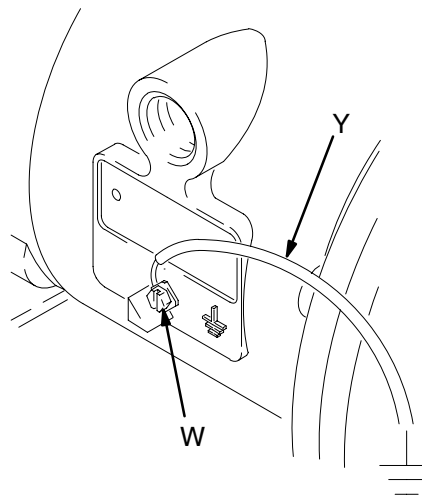

Fig. 1

02646B

- *Air and fluid hoses:* Use only grounded hoses with a maximum of 500 ft (150 m) combined hose length to ensure grounding continuity.
- *Air compressor:* Follow the manufacturer's recommendations.
- *All solvent pails used when flushing:* Follow the local code. Use only grounded metal pails, which are conductive. Do not place the pail on a non-conductive surface, such as paper or cardboard, which interrupts the grounding continuity.
- *Fluid supply container:* Follow the local code.

Installation

Air Line

⚠ WARNING

A bleed-type master air valve (B) is required in your system to relieve air trapped between this valve and the pump. Trapped air can cause the pump to cycle unexpectedly, which could result in serious injury, including splashing in the eyes or on the skin, injury from moving parts, or contamination from hazardous fluids. See Fig. 2.

1. Install the air line accessories as shown in Fig. 2. Mount these accessories on the wall or on a bracket. Be sure the air line supplying the accessories is grounded.
 - a. Install an air regulator (C) and gauge to control the fluid pressure. The fluid outlet pressure will be the same as the setting of the air regulator.
 - b. Locate one bleed-type master air valve (B) close to the pump and use it to relieve trapped air. See the **WARNING** at left. Locate the other master air valve (E) upstream from all air line accessories and use it to isolate them during cleaning and repair.
 - c. The air line filter (F) removes harmful dirt and moisture from the compressed air supply.
2. Install a grounded, flexible air hose (A) between the accessories and the 1/2 npt(f) pump air inlet (N). See Fig. 2. Use a minimum 3/8" (10 mm) ID air hose. Screw an air line quick disconnect coupler (D) onto the end of the air hose (A), and screw the mating fitting into the pump air inlet snugly. Do not connect the coupler (D) to the fitting until you are ready to operate the pump.

FLOOR MOUNT TYPICAL INSTALLATION

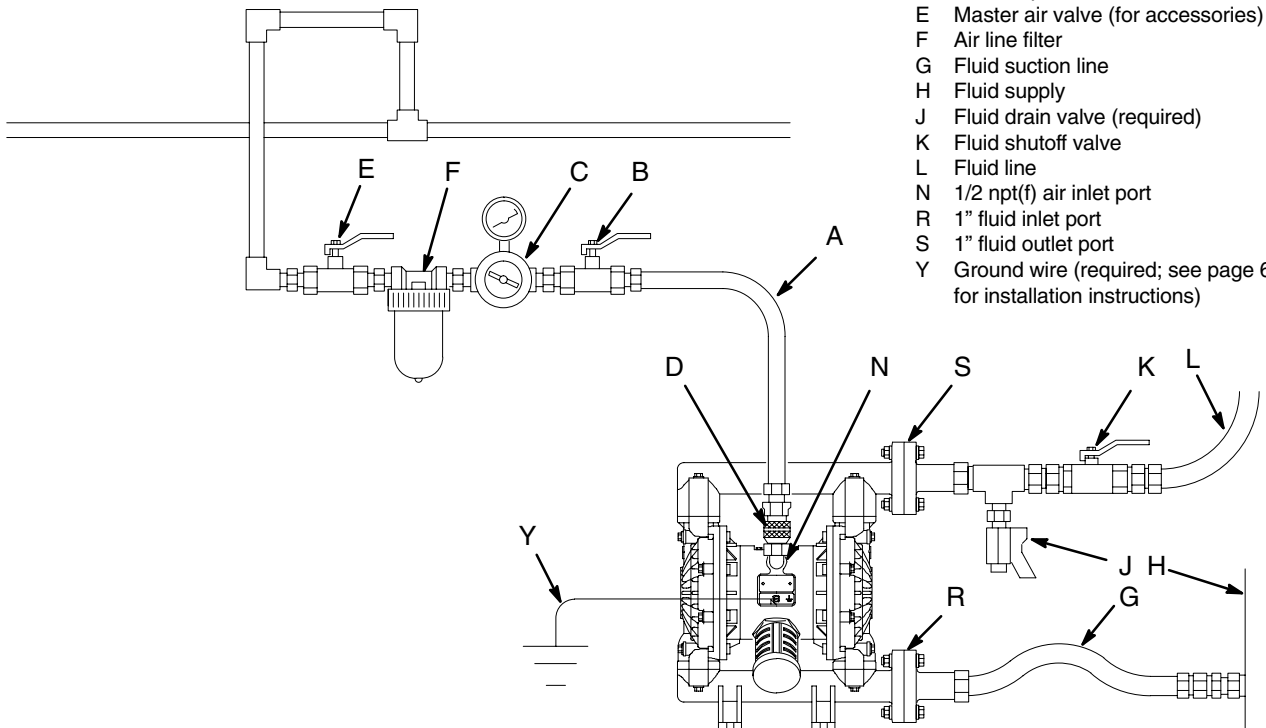

KEY

- A Air supply hose
- B Bleed-type master air valve (required for pump)
- C Air regulator
- D Air line quick disconnect
- E Master air valve (for accessories)
- F Air line filter
- G Fluid suction line
- H Fluid supply
- J Fluid drain valve (required)
- K Fluid shutoff valve
- L Fluid line
- N 1/2 npt(f) air inlet port
- R 1" fluid inlet port
- S 1" fluid outlet port
- Y Ground wire (required; see page 6 for installation instructions)

Fig. 2

04170B

Installation

Mountings

CAUTION

The pump exhaust air may contain contaminants. Ventilate to a remote area if the contaminants could affect your fluid supply. See **Air Exhaust Ventilation** on page 11.

1. Be sure the mounting surface can support the weight of the pump, hoses, and accessories, as well as the stress caused during operation.
2. For all mountings, be sure the pump is bolted directly to the mounting surface.
3. For ease of operation and service, mount the pump so the air valve cover (2), air inlet, and fluid inlet and outlet ports are easily accessible.
4. Rubber Foot Mounting Kit 236452 is available to reduce noise and vibration during operation.

Installation of Remote Pilot Air Lines

1. Refer to Parts Drawings. Connect air line to pump as in preceding steps.
2. Connect 1/4 in. O.D. tubing to push type connectors (14) on air motor of pump.

NOTE: by replacing the push type connectors, other sizes or types of fittings may be used. The new fittings will require 1/8 in. npt threads.

3. Connect remaining ends of tubes to external air signal, such as Graco's Cycleflo (P/N 195264) or Cycleflo II (P/N195265) controllers.

NOTE: the air pressure at the connectors must be at least 30% of the air pressure to the air motor for the pump to operate.

Fluid Suction Line

- If using a conductive (Acetal) pump, use conductive hoses (G). If using a non-conductive (polypropylene or PVDF) pump, ground the fluid system. See **Grounding** on page 6.
- The pump fluid inlet (R) is a 1" raised face flange. See **Flange Connections** on page 9.
- If the fluid inlet pressure to the pump is more than 25% of the outlet working pressure, the ball check valves will not close fast enough, resulting in inefficient pump operation.
- At inlet fluid pressures greater than 15 psi (104 kPa, 1 bar), diaphragm life will be shortened.
- See the **Technical Data** on page 32 for maximum suction lift (wet and dry).

Fluid Outlet Line

WARNING

A fluid drain valve (J) is required to relieve pressure in the hose if it is plugged. The drain valve reduces the risk of serious injury, including splashing in the eyes or on the skin, or contamination from hazardous fluids when relieving pressure. Install the valve close to the pump fluid outlet. See Fig. 2.

1. **Use grounded fluid hoses (L).** The pump fluid outlet (S) is a 1" raised face flange. Refer to **Flange Connections** on page 9.
2. Install a fluid drain valve (J) near the fluid outlet. See the **WARNING** above.
3. Install a shutoff valve (K) in the fluid outlet line.

Installation

Flange Connections

The fluid inlet and outlet ports are 1" raised face flanges. Connect 1" flanged plastic pipe to the pump as follows. You will need:

- Torque wrench
- Adjustable wrench
- One 4.25" diameter, 1/8" thick PTFE gasket, with four 0.62 diameter holes and a 1.15" diameter center
- Four 1/2" x 2.5" bolts
- Four 1/2" spring lockwashers
- Eight 1/2" flat washers
- Four 1/2" nuts.

1. Place a lockwasher and a flat washer on each bolt. Refer to Fig. 3.
2. Align the holes in the gasket and the pipe flange with the holes in the pump flange.
3. Lubricate the threads of the four bolts. Install the bolts through the holes and secure with the washers and nuts.
4. Hold the nuts with a wrench. Refer to the tightening sequence in Fig. 3 and torque the bolts to 10 to 15 ft-lb (14 to 20 N-m). **Do not over-torque.**

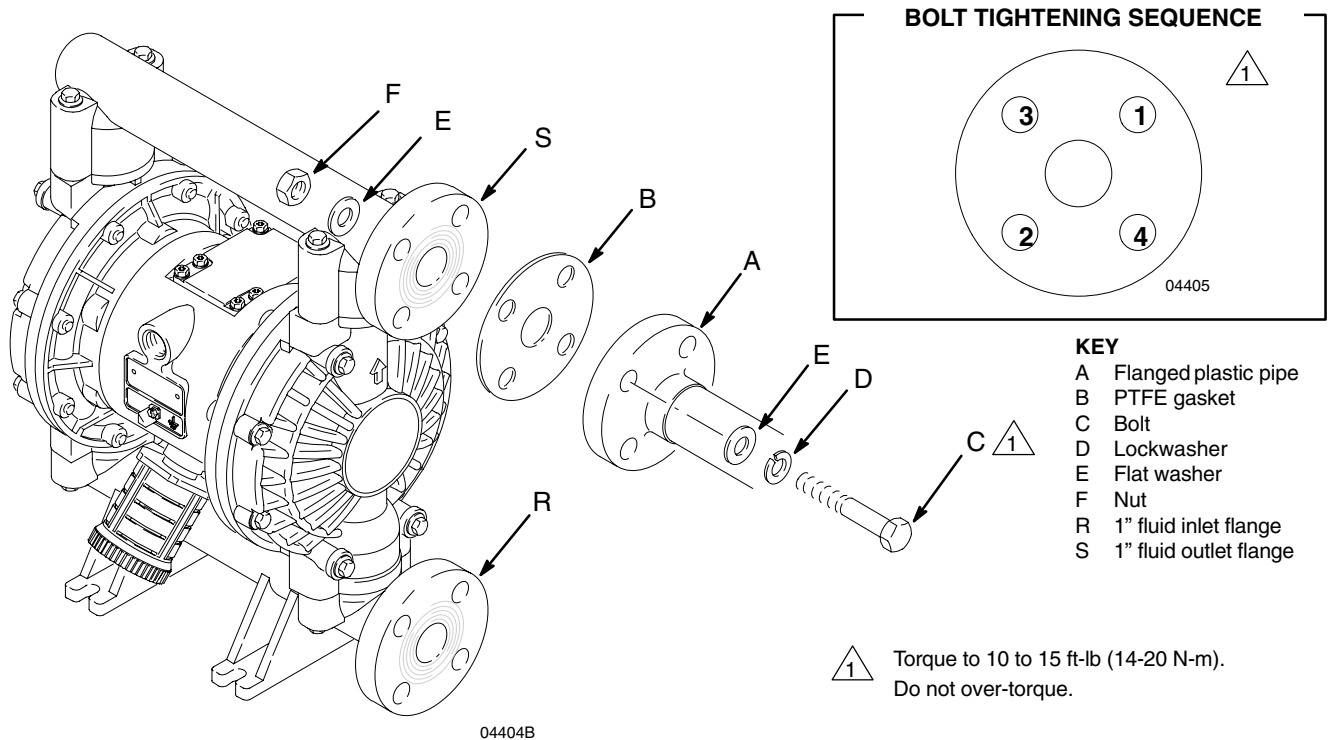

Fig. 3

Installation

Changing the Orientation of the Fluid Inlet and Outlet Ports

The pump is shipped with the fluid inlet (R) and outlet (S) ports facing the same direction. See Fig. 4. To change the orientation of the inlet and/or outlet port:

1. Remove the screws (106 or 112) holding the inlet (102) and/or outlet (103) manifold to the covers (101).
2. Reverse the manifold and reattach. Install the screws (106 or 112). Torque the manifold screws to 80 to 90 in-lb (9 to 10 N-m). See Fig. 4. See **Torque Sequence**, page 30.

KEY

N	1/2 npt(f) air inlet port	101	Covers
P	Muffler; air exhaust port is 3/4 npt(f)	102	Fluid inlet manifold
R	1" fluid inlet port	103	Fluid outlet manifold
S	1" fluid outlet port	106	Manifold screws
		112	Manifold screws

 Torque to 80 to 90 in-lb (9 to 10 N-m). See **Torque Sequence**, page 30.

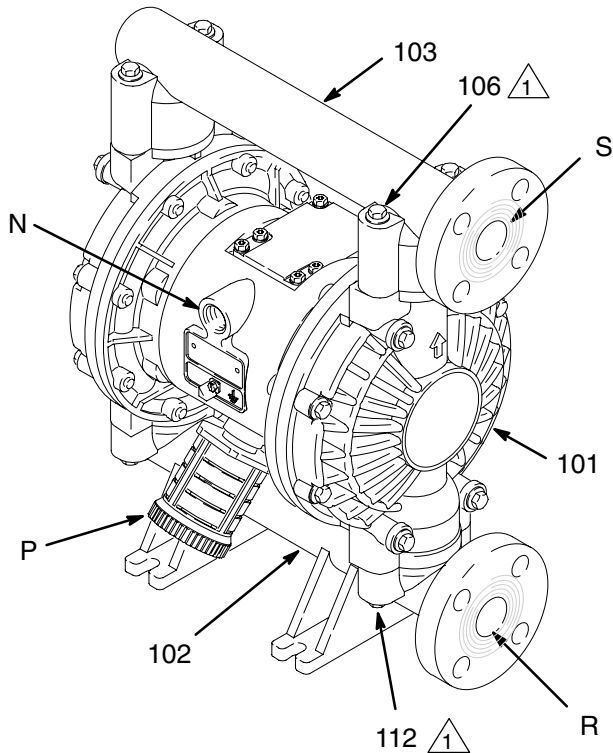

Acetal Model Shown

Fig. 4

04155B

Fluid Pressure Relief Valve

CAUTION



Some systems may require installation of a pressure relief valve at the pump outlet to prevent overpressurization and rupture of the pump or hose. See Fig. 5.

Thermal expansion of fluid in the outlet line can cause overpressurization. This can occur when using long fluid lines exposed to sunlight or ambient heat, or when pumping from a cool to a warm area (for example, from an underground tank).

Overpressurization can also occur if the Husky pump is being used to feed fluid to a piston pump, and the intake valve of the piston pump does not close, causing fluid to back up in the outlet line.

KEY

R	1" fluid inlet port
S	1" fluid outlet port
V	Pressure relief valve Part No. 112119 (stainless steel)

-  Install valve between fluid inlet and outlet ports.
-  Connect fluid inlet line here.
-  Connect fluid outlet line here.

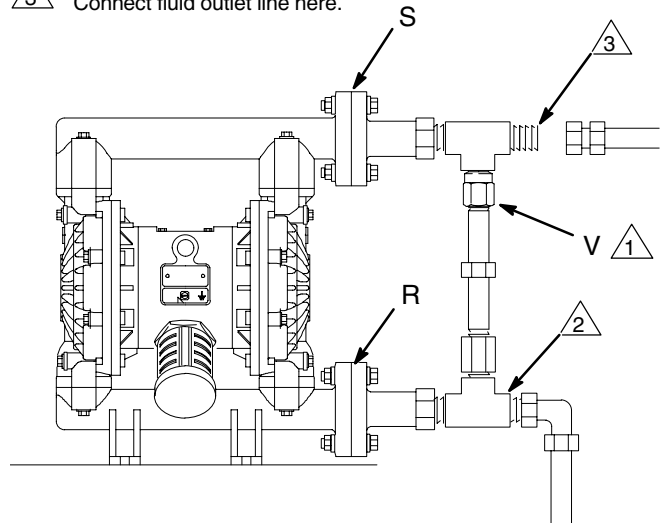

04228B

Fig. 5

Installation

Air Exhaust Ventilation

⚠ WARNING

FIRE AND EXPLOSION HAZARD
Be sure to read **FIRE OR EXPLOSION HAZARD** and **TOXIC FLUID HAZARD** on page 4, before operating this pump.

Be sure the system is properly ventilated for your type of installation. You must vent the exhaust to a safe place, away from people, animals, food handling areas, and all sources of ignition when pumping flammable or hazardous fluids.

Diaphragm failure will cause the fluid being pumped to exhaust with the air. Place an appropriate container at the end of the air exhaust line to catch the fluid. See Fig. 6.

The air exhaust port is 3/4 npt(f). Do not restrict the air exhaust port. Excessive exhaust restriction can cause erratic pump operation.

To provide a remote exhaust:

1. Remove the muffler (P) from the pump air exhaust port.
2. Install a grounded air exhaust hose (T) and connect the muffler (P) to the other end of the hose. The minimum size for the air exhaust hose is 3/4 in. (19 mm) ID. If a hose longer than 15 ft (4.57 m) is required, use a larger diameter hose. Avoid sharp bends or kinks in the hose. See Fig. 6.
3. Place a container (U) at the end of the air exhaust line to catch fluid in case a diaphragm ruptures.

VENTING EXHAUST AIR

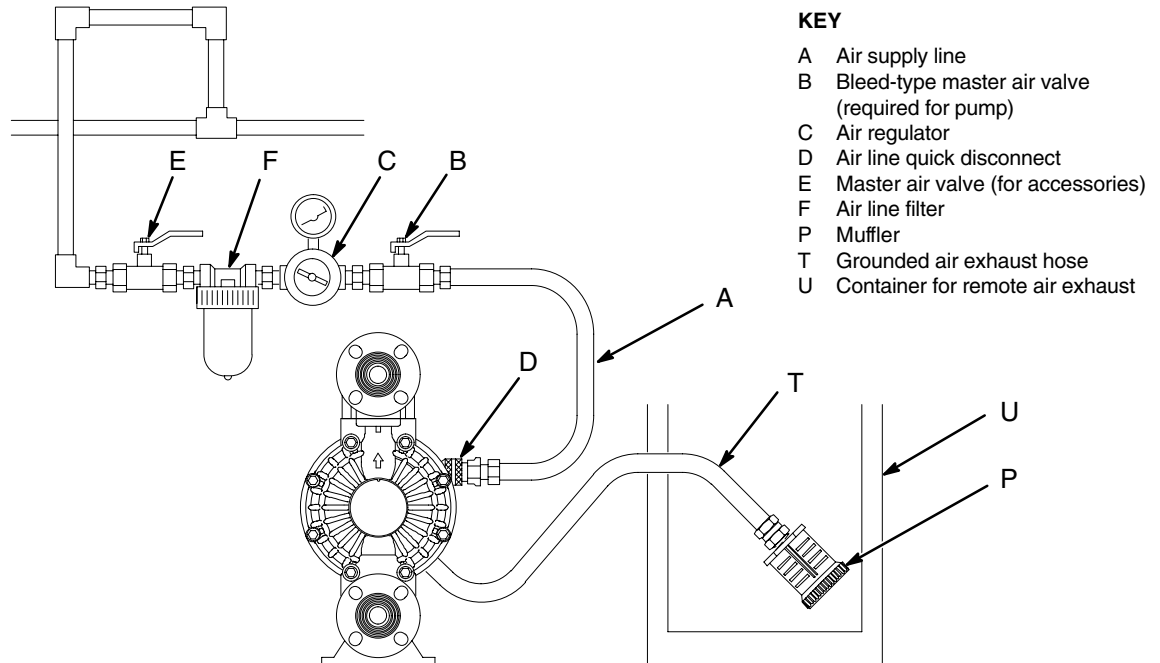

Fig. 6

04168A

Operation

Pressure Relief Procedure

WARNING

PRESSURIZED EQUIPMENT HAZARD

The equipment stays pressurized until pressure is manually relieved. To reduce the risk of serious injury from pressurized fluid, accidental spray from the gun or splashing fluid, follow this procedure whenever you

- Are instructed to relieve pressure
- Stop pumping
- Check, clean, or service any system equipment
- Install or clean fluid nozzles

1. Shut off the air to the pump.
2. Open the dispensing valve, if used.
3. Open the fluid drain valve to relieve all fluid pressure, having a container ready to catch the drainage.

Flush the Pump Before First Use

The pump was tested with lightweight oil, which is left in the fluid passages to protect parts. To avoid contaminating your fluid with oil, flush the pump with a compatible solvent before using the equipment. Follow the steps under **Starting and Adjusting the Pump**.

Starting and Adjusting the Pump

WARNING



TOXIC FLUID HAZARD

Hazardous fluid or toxic fumes can cause serious injury or death if splashed in the eyes or on the skin, inhaled, or swallowed. Do not lift a pump under pressure. If dropped, the fluid section may rupture. Always follow the **Pressure Relief Procedure** above before lifting the pump.

1. Be sure the pump is properly grounded. Refer to **Grounding** on page 6.
2. Check all fittings to be sure they are tight. Be sure to use a compatible liquid thread sealant on all male threads. Tighten the fluid inlet and outlet fittings securely.
3. Place the suction tube (if used) in the fluid to be pumped.

NOTE: If the fluid inlet pressure to the pump is more than 25% of the outlet working pressure, the ball check valves will not close fast enough, resulting in inefficient pump operation.

4. Place the end of the fluid hose (L) into an appropriate container.
5. Close the fluid drain valve (J). See Fig. 2.
6. With the pump air regulator (C) closed, open all bleed-type master air valves (B, E).
7. If the fluid hose has a dispensing device, hold it open while continuing with the following step.
8. Slowly open the air regulator (C) until the pump starts to cycle. Allow the pump to cycle slowly until all air is pushed out of the lines and the pump is primed.

If you are flushing, run the pump long enough to thoroughly clean the pump and hoses. Close the air regulator. Remove the suction tube from the solvent and place it in the fluid to be pumped.

Operation

Operation of Remote Piloted Pumps

1. Follow preceding steps 1 through 7 of **Starting and Adjusting Pump**.
2. Open air regulator (C).

WARNING

The pump may cycle once before the external signal is applied. Injury is possible. If pump cycles, wait until end before proceeding.

3. Pump will operate when air pressure is alternately applied and relieved to push type connectors (14).

NOTE: Leaving air pressure applied to the air motor for extended periods when the pump is not running may shorten the diaphragm life. Using a 3-way solenoid valve to automatically relieve the pressure on the air motor when the metering cycle is complete prevents this from occurring.

Pump Shutdown

WARNING

To reduce the risk of serious injury whenever you are instructed to relieve pressure, always follow the **Pressure Relief Procedure** at left.

At the end of the work shift, relieve the pressure.

Maintenance

Lubrication

The air valve is designed to operate unlubricated, however if lubrication is desired, every 500 hours of operation (or monthly) remove the hose from the pump air inlet and add two drops of machine oil to the air inlet.

CAUTION

Do not over-lubricate the pump. Oil is exhausted through the muffler, which could contaminate your fluid supply or other equipment. Excessive lubrication can also cause the pump to malfunction.

Flushing and Storage

Flush the pump often enough to prevent the fluid you are pumping from drying or freezing in the pump and damaging it. Always flush the pump and follow the **Pressure Relief Procedure** on page 12 before storing it for any length of time. Use a compatible solvent.

Tightening Threaded Connections

Before each use, check all hoses for wear or damage, and replace as necessary. Check to be sure all threaded connections are tight and leak-free. Check fasteners. Tighten or retorque as necessary. Although pump use varies, a general guideline is to retorque fasteners every two months. See **Torque Sequence**, page 30.

Preventive Maintenance Schedule

Establish a preventive maintenance schedule, based on the pump's service history. This is especially important for prevention of spills or leakage due to diaphragm failure.

Troubleshooting

WARNING

To reduce the risk of serious injury whenever you are instructed to relieve pressure, always follow the **Pressure Relief Procedure** on page 12.

1. Relieve the pressure before checking or servicing the equipment.
2. Check all possible problems and causes before disassembling the pump.

PROBLEM	CAUSE	SOLUTION
Pump cycles at stall or fails to hold pressure at stall.	Worn check valve balls (301), seats (201) or o-rings (202).	Replace. See page 18.
Pump will not cycle, or cycles once and stops.	Air valve is stuck or dirty.	Disassemble and clean air valve. See pages 16 to 17. Use filtered air.
	Check valve ball (301) severely worn and wedged in seat (201) or manifold (102 or 103).	Replace ball and seat. See page 18.
	Check valve ball (301) is wedged into seat (201), due to overpressurization.	Install Pressure Relief Valve (see page 10).
	Dispensing valve clogged.	Relieve pressure and clear valve.
Pump operates erratically.	Clogged suction line.	Inspect; clear.
	Sticky or leaking balls (301).	Clean or replace. See page 18.
	Diaphragm ruptured.	Replace. See pages 19 to 21.
	Restricted exhaust.	Remove restriction.
Air bubbles in fluid.	Suction line is loose.	Tighten.
	Diaphragm ruptured.	Replace. See pages 19 to 21.
	Loose inlet manifold (102), damaged seal between manifold and seat (201), damaged o-rings (202).	Tighten manifold bolts (106 or 112) or replace seats (201) or o-rings (202). See page 18.
	Loose fluid side plate (105).	Tighten or replace (pages 19 to 21).
	Damaged o-ring (108).	Replace. See pages 19 to 21.

Troubleshooting

PROBLEM	CAUSE	SOLUTION
Fluid in exhaust air.	Diaphragm ruptured.	Replace. See pages 19 to 21.
	Loose fluid side plate (105).	Tighten or replace (pages 19 to 21).
Pump exhausts excessive air at stall.	Worn air valve block (7), o-ring (6), plate (8), pilot block (18), u-cups (10), or pilot pin o-rings (17).	Repair or replace. See pages 16 to 17.
	Worn shaft seals (402).	Replace. See pages 19 to 21.
Pump leaks air externally.	Air valve cover (2) or air valve cover screws (3) are loose.	Tighten screws. See page 17.
	Air valve gasket (4) or air cover gasket (22) is damaged.	Inspect; replace. See pages 16 to 17 and 22 to 23.
	Air cover screws (25) are loose.	Tighten screws. See pages 22 to 23.
Pump leaks fluid externally from ball check valves.	Loose manifolds (102, 103), damaged seal between manifold and seat (201), damaged o-rings (202).	Tighten manifold bolts (106 or 112) or replace seats (201) or o-rings (202). See page 18.

Service

Repairing the Air Valve

Tools Required

- Torque wrench
- Torx (T20) screwdriver or 7 mm (9/32") socket wrench
- Needle-nose pliers
- O-ring pick
- Lithium base grease

NOTE: Air Valve Repair Kits 236273 (aluminum center housing models) and 255061 (sst center housing models) are available. Refer to page 26. Parts included in the kit are marked with a symbol, for example (4†■). Use all the parts in the kit for the best results.

Disassembly

⚠ WARNING

To reduce the risk of serious injury whenever you are instructed to relieve pressure, always follow the **Pressure Relief Procedure** on page 12.

1. Relieve the pressure.
2. With a Torx (T20) screwdriver or 7 mm (9/32") socket wrench, remove the six screws (3), air valve cover (2), and gasket (4). See Fig. 7.
3. Move the valve carriage (5) to the center position and pull it out of the cavity. Remove the valve block (7†■) and o-ring (6†■) from the carriage. Using a needle-nose pliers, pull the pilot block (18) straight up and out of the cavity. See Fig. 8.
4. Pull the two actuator pistons (11) out of the bearings (12). Remove the u-cup packings (10) from the pistons. Pull the pilot pins (16) out of the bearings (15). Remove the o-rings (17) from the pilot pins. See Fig. 9.
5. Inspect the valve plate (8) in place. If damaged, use a Torx (T20) screwdriver or 7 mm (9/32") socket wrench to remove the three screws (3). Remove the valve plate (8) and, on aluminum center housing models only, remove the seal (9). See Fig. 10.
6. Inspect the bearings (12, 15) in place. See Fig. 9. The bearings are tapered and, if damaged, must be removed from the outside. This requires disassembly of the fluid section. See page 22.

7. Clean all parts and inspect for wear or damage. Replace as needed. Reassemble as explained on page 17.

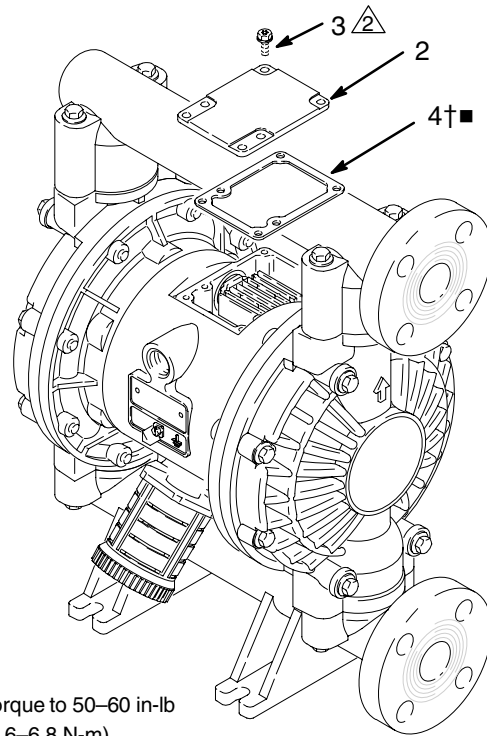

△ 2 Torque to 50–60 in-lb (5.6–6.8 N-m).

04164B

Fig. 7

- △ 1 See Detail at right.
- △ 2 Grease.
- △ 3 Grease lower face.

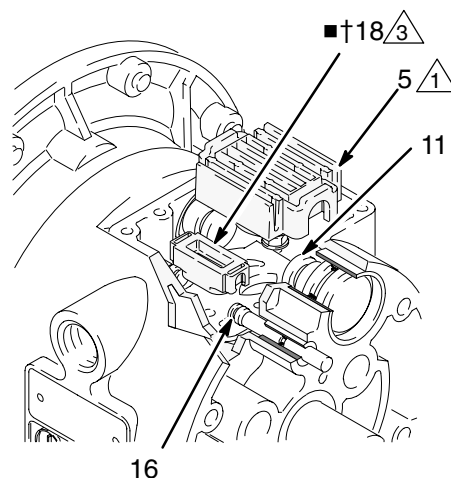
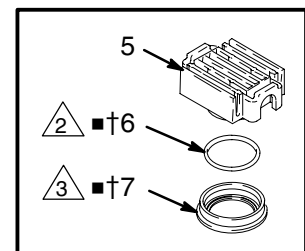

Fig. 8

04165

Service

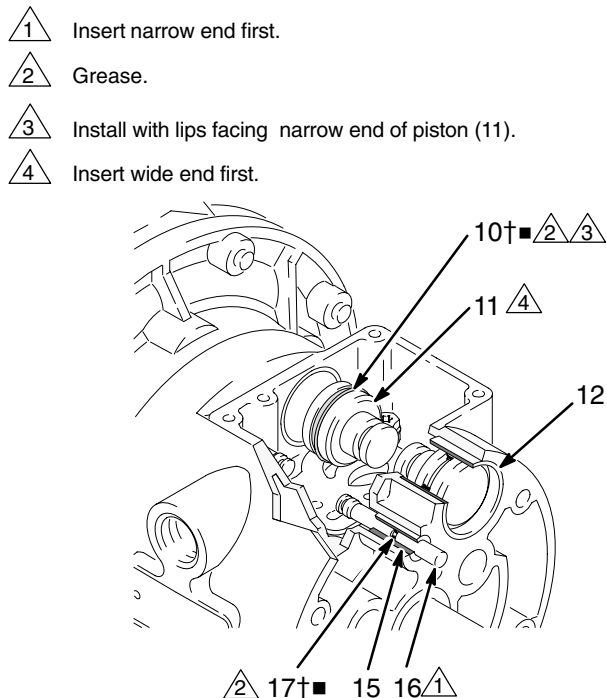

Fig. 9

04159

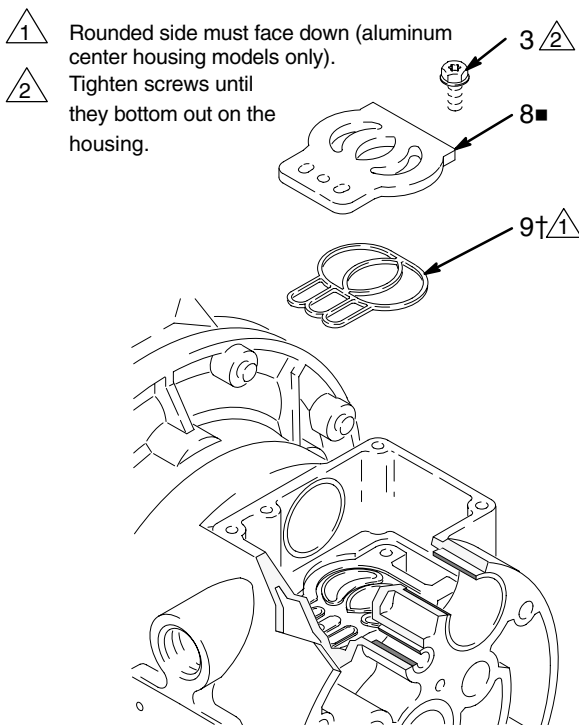

Fig. 10

04160

Reassembly

1. If you removed the bearings (12, 15), install new ones as explained on page 22. Reassemble the fluid section.
2. On aluminum center housing models, install the valve plate seal (9†) into the groove at the bottom of the valve cavity. The rounded side of the seal **must face down** into the groove. See Fig. 10.
3. Install the valve plate (8■) in the cavity. On aluminum center housing models, the plate is reversible, so either side can face up. Install the three screws (3), using a Torx (T20) screwdriver or 7 mm (9/32") socket wrench. Tighten until the screws bottom out on the housing. See Fig. 10.
4. Install an o-ring (17†■) on each pilot pin (16). Grease the pins and o-rings. Insert the pins into the bearings (15), **narrow** end first. See Fig. 9.
5. Install a u-cup packing (10†■) on each actuator piston (11), so the lips of the packings face the **narrow** end of the pistons. See Fig. 9.
6. Lubricate the u-cup packings (10†■) and actuator pistons (11). Insert the actuator pistons in the bearings (12), **wide** end first. Leave the narrow end of the pistons exposed. See Fig. 9.
7. Grease the lower face of the pilot block (18†■) and install so its tabs snap into the grooves on the ends of the pilot pins (16). See Fig. 8.
8. Grease the o-ring (6†■) and install it in the valve block (7†). Push the block onto the valve carriage (5). Grease the lower face of the valve block. See Fig. 8.
9. Install the valve carriage (5) so its tabs slip into the grooves on the narrow end of the actuator pistons (11). See Fig. 8.
10. Align the valve gasket (4†■) and cover (2) with the six holes in the center housing (1). Secure with six screws (3), using a Torx (T20) screwdriver or 7 mm (9/32") socket wrench. Torque to 28 to 33 in-lb (3.2 to 3.7 N.m). See Fig. 7.

Service

Ball Check Valve Repair

Tools Required

- Torque wrench
- 10 mm socket wrench
- O-ring pick

Disassembly

NOTE: A Fluid Section Repair Kit is available. Refer to page 25 to order the correct kit for your pump. Parts included in the kit are marked with an asterisk, for example (201*). Use all the parts in the kit for the best results.

NOTE: To ensure proper seating of the balls (301), always replace the seats (201) when replacing the balls.

⚠ WARNING

To reduce the risk of serious injury whenever you are instructed to relieve pressure, always follow the **Pressure Relief Procedure** on page 12.

1. Relieve the pressure. Disconnect all hoses.
2. Remove the pump from its mounting.
3. Using a 10 mm socket wrench, remove the four bolts (106) holding the outlet manifold (103) to the fluid covers (101). See Fig. 11.
4. Remove the seats (201), balls (301), and o-rings (202) from the manifold.

NOTE: Some models use two o-rings (202), some models use four o-rings (202), and some models do not use o-rings.

5. Turn the pump over and remove the inlet manifold (102). Remove the seats (201), balls (301), and o-rings (202) from the fluid covers (101).

Reassembly

1. Clean all parts and inspect for wear or damage. Replace parts as needed.
2. Reassemble in the reverse order, following all notes in Fig. 11. Assemble the ball checks **exactly** as shown. The arrows (A) on the fluid covers (101) **must** point toward the outlet manifold (103).

- 1 Torque to 80 to 90 in-lb (9 to 10 N-m). See **Torque Sequence**, page 30.
- 2 Arrow (A) must point toward outlet manifold (103).
- 3 Not used on some models.
- 4 Beveled seating surface must face ball (301).

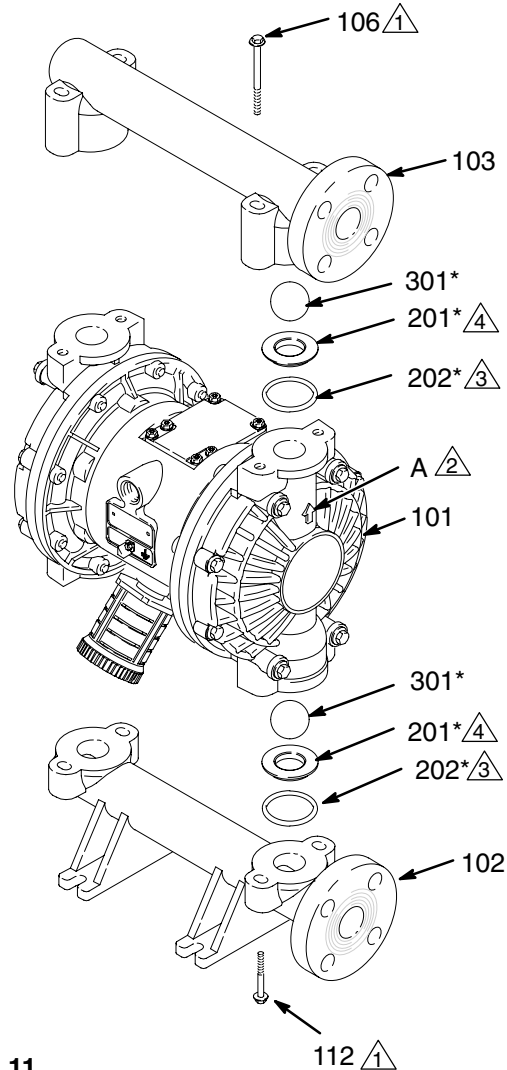

Fig. 11

04157B

Service

Diaphragm Repair

Tools Required

- Torque wrench
- 10 mm socket wrench
- 19 mm open-end wrench
- Adjustable wrench
- O-ring pick
- Lithium-base grease

Disassembly

NOTE: A Fluid Section Repair Kit is available. Refer to page 25 to order the correct kit for your pump. Parts included in the kit are marked with an asterisk, for example (401*). Use all the parts in the kit for the best results.

⚠ WARNING

To reduce the risk of serious injury whenever you are instructed to relieve pressure, always follow the **Pressure Relief Procedure** on page 12.

1. Relieve the pressure.
2. Remove the manifolds and disassemble the ball check valves as explained on page 18.
3. Using a 10 mm socket wrench, remove the screws (106 and 112) holding the fluid covers (101) to the air covers (23). Pull the fluid covers (101) off the pump. See Fig. 12.

1 You must torque the eight long screws (106) first, then the short screws (112). Torque to 130 to 150 in-lb (14 to 17 N•m). See **Torque Sequence**, page 30.

2 Arrow (A) must point toward air valve (B).

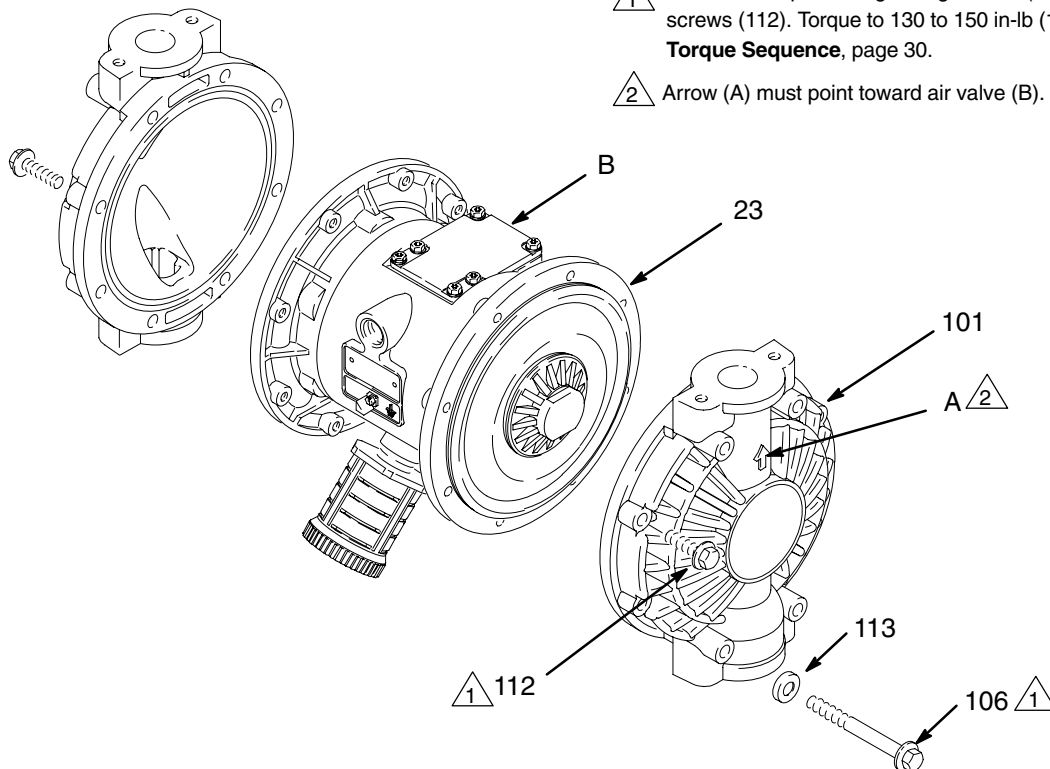

Fig. 12

04162B

Service

4. Unscrew one outer plate (105) from the diaphragm shaft (24). Remove one diaphragm (401), and the inner plate (104). See Fig. 13.

For overmolded diaphragms: Grip both diaphragms securely around the outer edge and rotate counterclockwise. One diaphragm assembly will come free and the other will remain attached to the shaft. Remove the freed diaphragm and air side plate.

NOTE: PTFE models include a PTFE diaphragm (403) in addition to the backup diaphragm (401).

5. Pull the other diaphragm assembly and the diaphragm shaft (24) out of the center housing (1). Hold the shaft flats with a 19 mm open-end wrench, and remove the outer plate (105) from the shaft. Disassemble the remaining diaphragm assembly.

For overmolded diaphragms: Pull the other diaphragm assembly and the diaphragm shaft (24) out of the center housing (1). Hold the shaft flats with a 19 mm open-end wrench and remove the diaphragm and air side plate from the shaft.

6. Inspect the diaphragm shaft (24) for wear or scratches. If it is damaged, inspect the bearings (19) in place. If the bearings are damaged, refer to page 22.
7. Reach into the center housing (1) with an o-ring pick and hook the u-cup packings (402), then pull them out of the housing. This can be done with the bearings (19) in place.
8. Clean all parts and inspect for wear or damage. Replace parts as needed.

Reassembly

1. Grease the shaft u-cup packings (402*) and install them so the lips face **out** of the housing (1). See Fig. 13.
2. Grease the length and ends of the diaphragm shaft (24), and slide it through the housing (1).
3. Assemble the inner diaphragm plates (104), diaphragms (401*), PTFE diaphragms (403*, if present), and outer diaphragm plates (105) *exactly* as shown in Fig. 13. These parts **must** be assembled correctly.

For overmolded diaphragms: Assemble the air side plate (104) onto the diaphragm (403). The wide, radiused side of the plate must face the diaphragm. Apply medium-strength (blue) Loctite or equivalent to the threads of the diaphragm assembly. Screw the assembly into the shaft (24) hand tight. **NOTE:** *Step 4 does not apply to pumps with overmolded diaphragms; go to step 5.*

4. Apply medium-strength (blue) Loctite® or equivalent to the threads of the fluid-side plates (105). Hold one of the outer plates (105) with a wrench, and torque the other outer plate to 20 to 25 ft-lb (27 to 34 N-m) at 100 rpm maximum. **Do not over-torque.**
5. Align the fluid covers (101) and the center housing (1) so the arrows (A) on the covers face the same direction as the air valve (B). Secure the covers with the screws (106 and 112), handtight. Place the bolt caps (113*) on the longer screws (106), and install the longer screws in the top and bottom holes of the covers. See Fig. 12.
6. First, torque the longer screws (106) oppositely and evenly to 130 to 150 in-lb (14 to 17 N•m), using a 10 mm socket wrench. Then torque the shorter screws (112). See **Torque Sequence**, page 30.
7. Reassemble the ball check valves and manifolds as explained on page 18.

Service

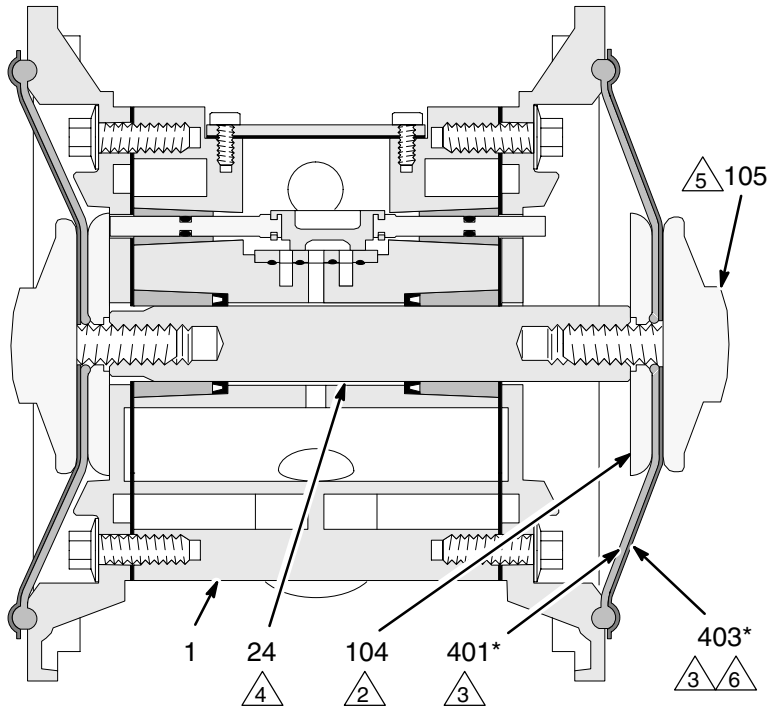

Cutaway View, with Diaphragms in Place

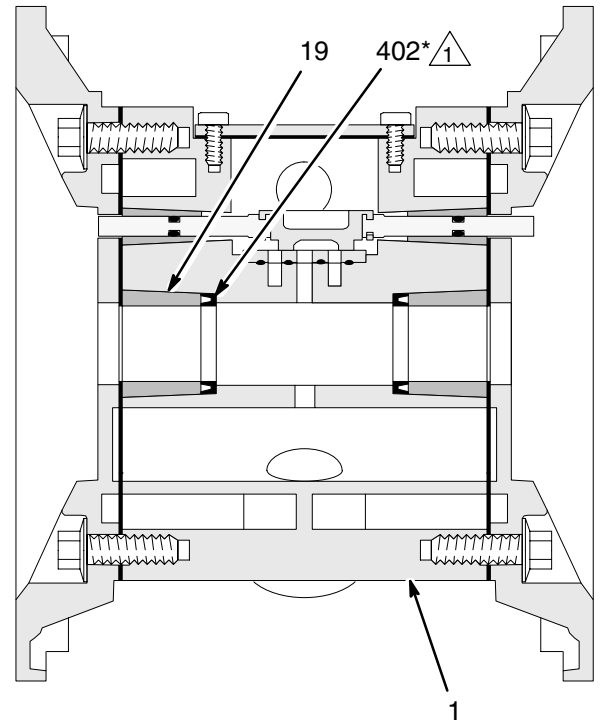

Cutaway View, with Diaphragms Removed

04236

02637

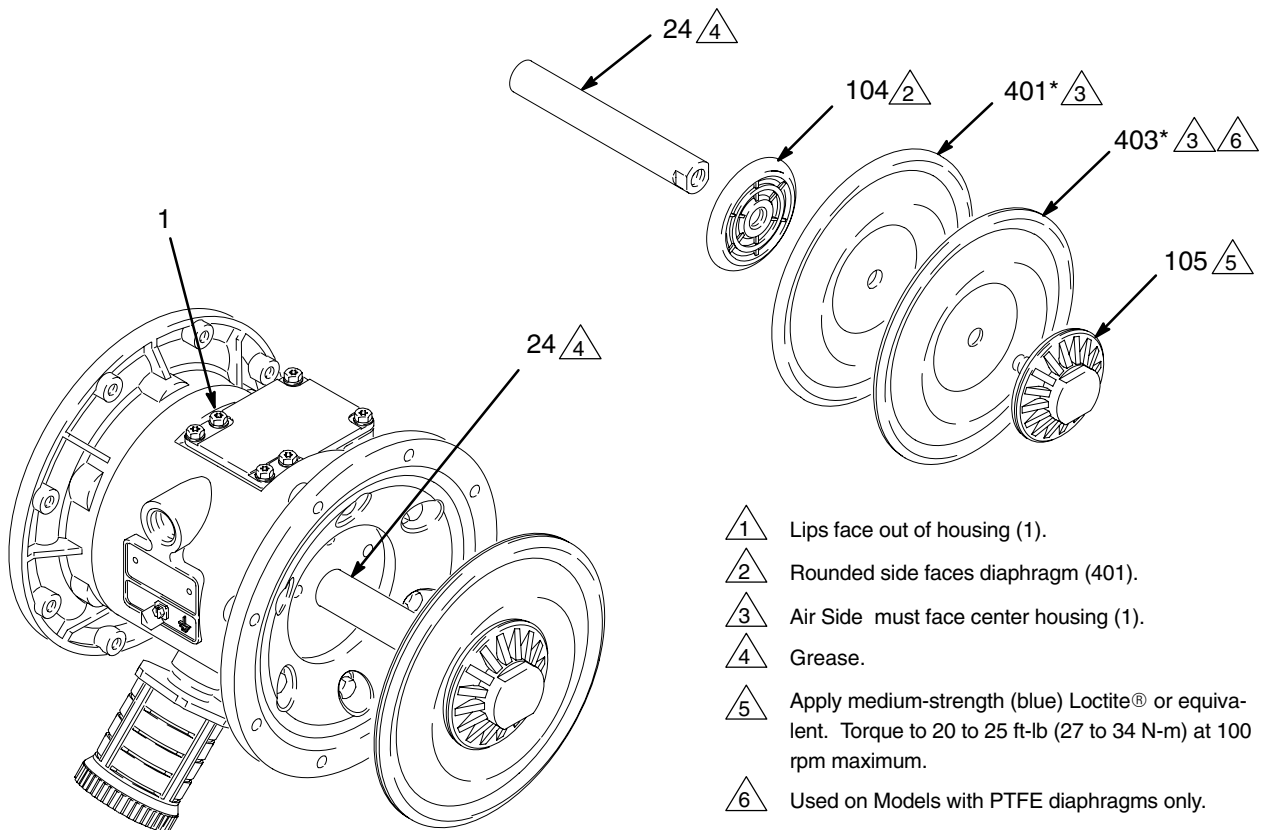

- △ 1 Lips face out of housing (1).
- △ 2 Rounded side faces diaphragm (401).
- △ 3 Air Side must face center housing (1).
- △ 4 Grease.
- △ 5 Apply medium-strength (blue) Loctite® or equivalent. Torque to 20 to 25 ft-lb (27 to 34 N-m) at 100 rpm maximum.
- △ 6 Used on Models with PTFE diaphragms only.

Fig. 13

04161B

Service

Bearing and Air Gasket Removal

Tools Required

- Torque wrench
- 10 mm socket wrench
- Bearing puller
- O-ring pick
- Press, or block and mallet

Disassembly

NOTE: Do not remove undamaged bearings.

WARNING

To reduce the risk of serious injury whenever you are instructed to relieve pressure, always follow the **Pressure Relief Procedure** on page 12.

1. Relieve the pressure.
 2. Remove the manifolds and disassemble the ball check valves as explained on page 18.
 3. Remove the fluid covers and diaphragm assemblies as explained on page 19.
- NOTE:** If you are removing only the diaphragm shaft bearing (19), skip step 4.
4. Disassemble the air valve as explained on page 16.
 5. Using a 10 mm socket wrench, remove the screws (25) holding the air covers (23) to the center housing (1). See Fig. 14.
 6. Remove the air cover gaskets (22). Always replace the gaskets with new ones.
 7. Use a bearing puller to remove the diaphragm shaft bearings (19), air valve bearings (12) or pilot pin bearings (15). Do not remove undamaged bearings.
 8. If you removed the diaphragm shaft bearings (19), reach into the center housing (1) with an o-ring pick and hook the u-cup packings (402), then pull them out of the housing. Inspect the packings. See Fig. 13.

Reassembly

1. If removed, install the shaft u-cup packings (402*) so the lips face **out** of the housing (1).
2. The bearings (19, 12, and 15) are tapered and can only be installed one way. Insert the bearings into the center housing (1), **tapered end first**. Using a press or a block and rubber mallet, press-fit the bearing so it is flush with the surface of the center housing.
3. Reassemble the air valve as explained on page 17.
4. Align the new air cover gasket (22) so the pilot pin (16) protruding from the center housing (1) fits through the proper hole (H) in the gasket.
5. Align the air cover (23) so the pilot pin (16) fits in the middle hole (M) of the three small holes near the center of the cover. Apply medium-strength (blue) Loctite® or equivalent to the threads of screws (25), and install the screws handtight. See Fig. 14. Using a 10 mm socket wrench, torque the screws oppositely and evenly to 130 to 150 in-lb (14 to 17 N•m).
6. Install the diaphragm assemblies and fluid covers as explained on page 19.
7. Reassemble the ball check valves and manifolds as explained on page 18.

Service

- 1 Insert bearings tapered end first.
- 2 Press-fit bearings flush with surface of center housing (1).
- 3 Apply medium-strength (blue) Loctite® or equivalent. Torque to 130 to 150 in-lb (14 to 17 N•m).

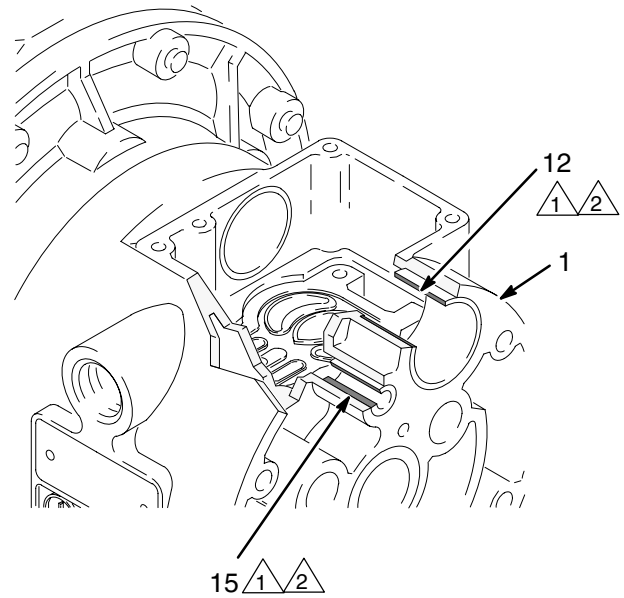

04158

Detail of Air Valve Bearings

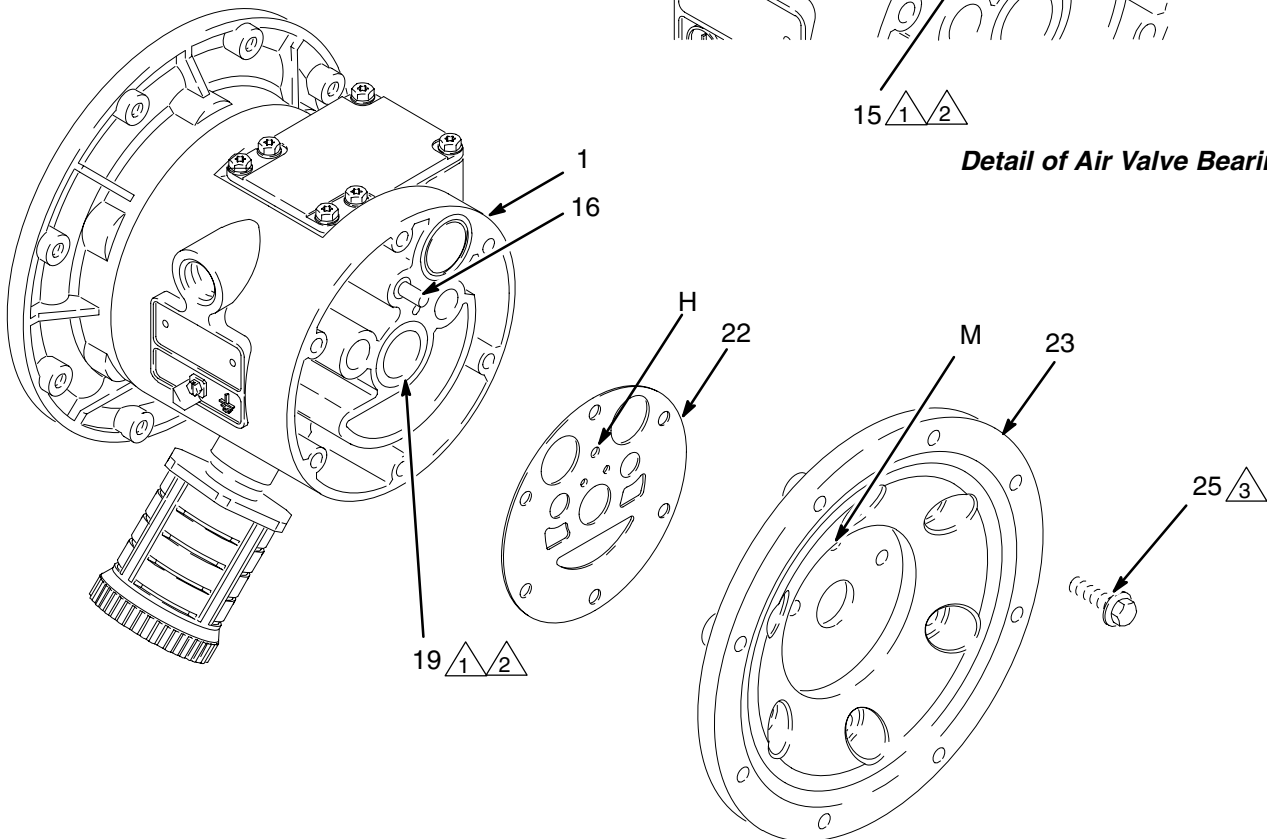

02639B

Fig. 14

Pump Matrix

Husky 1040 Acetal, Polypropylene, and PVDF Pumps, Series A

Your Model No. is marked on the pump's serial plate. To determine the Model No. of your pump from the following matrix, select the six digits which describe your pump, working from left to right. The first digit is always **D**, designating Husky diaphragm pumps. The remaining five digits define the materials of construction. For example, a pump with an aluminum air motor, acetal fluid section, polypropylene seats, PTFE balls, and PTFE diaphragms is Model **D 7 1 9 1 1**. To order replacement parts, refer to the part lists on pages 26 to 27. *The digits in the matrix do not correspond to the ref. nos. in the parts drawing and lists.*

Diaphragm Pump	Air Motor	Fluid Section	–	Seats	Balls	Diaphragms
D (for all pumps)	7 Aluminum (standard)	1 (acetal)	–	1 (not used)	1 (PTFE)	1 (PTFE)
24B754*	8 Aluminum (remote)	2 (polypropylene)	–	2 (acetal)	2 (acetal)	2 (not used)
24B755*	R SST (standard)	3 (not used)	–	3 (316 sst)	3 (316 sst)	3 (not used)
24B756*	S SST (remote)	4 (not used)	–	4 (17–4 PH sst)	4 (440C sst)	4 (not used)
24B757*		5 (PVDF)	–	5 (TPE)	5 (TPE)	5 (TPE)
24B831*			–	6 (not used)	6 (Santoprene®)	6 (Santoprene®)
			–	7 (buna-N)	7 (buna-N)	7 (buna-N)
			–	8 (fluoroelastomer)	8 (fluoroelastomer)	8 (fluoroelastomer)
			–	9 (polypropylene)	9 (not used)	9 (not used)
			–	A (PVDF)	A (not used)	A (not used)
			–	G (not used)	G (Geolast®)	G (Geolast®)

* 24B754 PVDF Plus Pump

This pump is the same as Model DR5A11 except for the serial plate and parts listed in the chart below.

* 24B755 Polypropylene Plus Pump

This pump is the same as Model DR2911 except for the serial plate and parts listed in the chart below.

* 24B756 Polypropylene Pump

This pump is the same as Model D72911 except for the serial plate and parts listed in the chart below.

* 24B757 Polypropylene Pump

This pump is the same as Model D72311 except for the serial plate and parts listed in the chart below.

* 24B831 PVDF Pump

This pump is the same as Model D75A11 except for the serial plate and parts listed in the chart below.

Ref. No.	Part No.	Description	Qty
104	15H809	PLATE, air side; alum.	2
105	—	not used	0
401	15G744	DIAPHRAGM, HD, overmolded; PTFE/EPDM	2

246450 Stainless Steel Air Motor Conversion Kit

Use kit 246450 and refer to instruction manual 309643 (included with kit) to convert from aluminum air motor to stainless steel air motor.

24 308443

Repair Kit Matrix

For Husky 1040 Acetal, Polypropylene, and PVDF Pumps, Series A

Repair Kits may be ordered separately. To repair the air valve, order **Part No. 236273** for aluminum center housing models and **Part 255061** for stainless steel center housing models (see page 26). Parts included in the Air Valve Repair Kit are marked with a symbol in the parts list, for example (3).

To repair your pump, select the six digits which describe your pump from the following matrix, working from left to right. The first digit is always **D**, the second digit is always **0** (zero), and the third is always **7**. The remaining three digits define the materials of construction. Parts included in the kit are marked with an asterisk in the parts list, for example (201*). For example, if your pump has polypropylene seats, PTFE balls, and PTFE diaphragms, order Repair Kit **D 0 7 9 1 1**. If you only need to repair certain parts (for example, the diaphragms), use the 0 (null) digits for the seats and balls, and order Repair Kit **D 0 7 0 0 1**. *The digits in the matrix do not correspond to the ref. nos. in the parts drawing and lists on pages 26 to 27.*

Diaphragm Pump	Null	Fluid Section Material	–	Seats	Balls	Diaphragms
D (for all pumps)	0 (for all pumps)	7 (Plastic)	–	0 (null)	0 (null)	0 (null)
			–	1 (not used)	1 (PTFE)	1 (PTFE)
			–	2 (acetal)	2 (acetal)	2 (not used)
			–	3 (316 sst)	3 (316 sst)	3 (not used)
			–	4 (17–4 PH sst)	4 (440C sst)	4 (not used)
			–	5 (TPE)	5 (TPE)	5 (TPE)
			–	6 (Santoprene®)	6 (Santoprene®)	6 (Santoprene®)
			–	7 (buna–N)	7 (buna-N)	7 (buna-N)
			–	8 (fluoroelastomer)	8 (fluoroelastomer)	8 (fluoroelastomer)
			–	9 (polypropylene)	9 (not used)	9 (not used)
			–	A (PVDF)	A (not used)	A (not used)
			–	G (Geolast®)	G (Geolast®)	G (Geolast®)

Part No. 253626: Husky 1040 HD Overmolded PTFE/EPDM Diaphragm Repair Kit.

Part No. 289224: Husky 1040 HD Overmolded PTFE/EPDM Diaphragm Repair Kit, with new air side diaphragm plates.

Parts

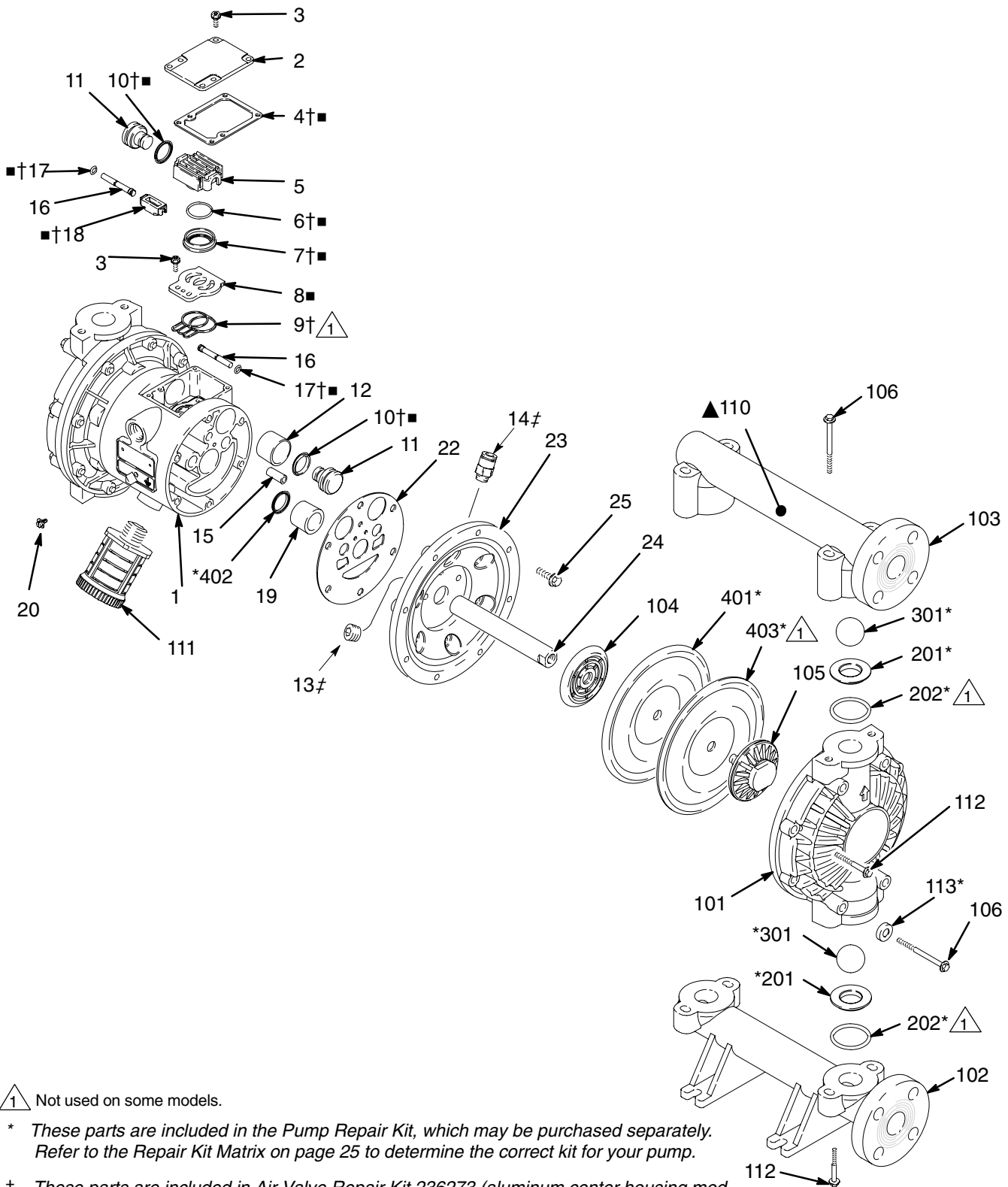

⚠ Not used on some models.

* These parts are included in the Pump Repair Kit, which may be purchased separately. Refer to the Repair Kit Matrix on page 25 to determine the correct kit for your pump.

† These parts are included in Air Valve Repair Kit 236273 (aluminum center housing models), which may be purchased separately.

■ These parts are included in Air Valve Repair Kit 255061 (stainless steel center housing models) which may be purchased separately.

▲ Replacement Danger and Warning labels, tags and cards are available at no cost.

‡ These parts are unique to remote piloted air motor, D8— and DS—

Parts

Air Motor Parts List (Matrix Column 2)

Digit	Ref. No.	Part No.	Description	Qty
7	1	188838	HOUSING, center; aluminum	1
	2	188854	COVER, air valve; aluminum	1
	3	116344	SCREW, mach, hex flange hd; M5 x 0.8; 12 mm (0.47 in.)	9
	4†■	188618	GASKET, cover; foam	1
	5	188855	CARRIAGE; aluminum	1
	6†■	108730	O-RING; nitrile	1
	7†■	188616	BLOCK, air valve; acetal	1
	8	188615	PLATE, air valve; sst	1
	9†	188617	SEAL, valve plate; buna-N	1
	10†■	112181	PACKING, u-cup; nitrile	2
	11	188612	PISTON, actuator; acetal	2
	12	188613	BEARING, piston; acetal	2
	13‡	104765	PLUG, pipe; headless	2
	14‡	115671	FITTING, connector; male	2
	15	188611	BEARING, pin; acetal	2
	16	188610	PIN, pilot; stainless steel	2
	17†■	157628	O-RING; buna-N	2
	18†■	188614	BLOCK, pilot; acetal	1
	19	188609	BEARING, shaft; acetal	2
	20	116343	SCREW, grounding	1
	22	188603	GASKET, air cover; foam	2
	23	188839	COVER, air; aluminum	2
	24	188608	SHAFT, diaphragm; sst	1
	25	115643	SCREW; M8 x 1.25; 25 mm (1 in.)	12

Air Motor Parts List (Matrix Column 2)

Digit	Ref. No.	Part No.	Description	Qty
8	Same as 7 with the following exceptions			
	1	195921	HOUSING, center; remote, aluminum	1
	23	195917	COVER, air; remote	2
R	Same as 7 with the following exceptions			
	1	15K009	HOUSING, center; stainless steel	1
	2	15A735	COVER, air valve; stainless steel	1
	8■	15H178	PLATE, air valve, stainless steel	1
	9	-	-	-
	23	15A736	COVER, air; stainless steel	2
	S	Same as 7 with the following exceptions		
1		15K009	HOUSING, center; remote, stainless steel	1
2		15A735	COVER, air valve; stainless steel	1
8■		15H178	PLATE, air valve, stainless steel	1
9		-	-	-
23		15B794	COVER, air; remote, stainless steel	2

Parts

Fluid Section Parts List (Matrix Column 3)

Digit	Ref. No.	Part No.	Description	Qty
1	101	189377	COVER, fluid; acetal	2
	102	189371	MANIFOLD, inlet; acetal	1
	103	189374	MANIFOLD, outlet; acetal	1
	104	188607	PLATE, air side; alum.	2
	105	189380	PLATE, fluid side; acetal	2
	106	112560	SCREW; M8 x 1.25; 70 mm (2.76 in.); sst	12
	110▲	188621	LABEL, warning	1
	111	112182	MUFFLER	1
	112	112559	SCREW; M8 x 1.25; 40 mm (1.57 in.); sst	12
	113*	193282	CAP, bolt; SST	8
	2	101	189376	COVER, fluid; polypropylene
102		189370	MANIFOLD, inlet; polypropylene	1
103		189373	MANIFOLD, outlet; polypropylene	1
104		188607	PLATE, air side; alum.	2
105		189379	PLATE, fluid side; polypropylene	2
106		112560	SCREW; M8 x 1.25; 70 mm (2.76 in.); sst	12
110▲		188621	LABEL, warning	1
111		112182	MUFFLER	1
112		112559	SCREW; M8 x 1.25; 40 mm (1.57 in.); sst	12
113*		193282	CAP, bolt; SST	8

Fluid Section Parts List (Matrix Column 3)

Digit	Ref. No.	Part No.	Description	Qty
5	101	189378	COVER, fluid; PVDF	2
	102	189372	MANIFOLD, inlet; PVDF	1
	103	189375	MANIFOLD, outlet; PVDF	1
	104	188607	PLATE, air side; alum.	2
	105	189381	PLATE, fluid side; PVDF	2
	106	112560	SCREW; M8 x 1.25; 70 mm (2.76 in.); sst	12
	110▲	188621	LABEL, warning	1
	111	112182	MUFFLER	1
	112	112559	SCREW; M8 x 1.25; 40 mm (1.57 in.); sst	12
	113*	193282	CAP, bolt; SST	8

Parts

Seat Parts List (Matrix Column 4)

Digit	Ref. No.	Part No.	Description	Qty
2	201*	188604	SEAT; acetal	4
	202*	109205	O-RING; PTFE	8
3	201*	188707	SEAT; 316 stainless steel	4
	202*	109205	O-RING; PTFE	8
4	201*	188708	SEAT; 17-4 stainless steel	4
	202*	109205	O-RING; PTFE	8
5	201*	188711	SEAT; TPE	4
	202	None	Not Used	0
6	201*	191595	SEAT; Santoprene®	4
	202*	114229	O-RING; PTFE encapsulated	8
7	201*	15B275	SEAT; Buna-N	4
	202	None	Not used	0
8	201*	15B633	SEAT; fluoroelastomer	4
	202	None	Not Used	0
9	201*	189722	SEAT; polypropylene	4
	202*	109205	O-RING; PTFE	8
A	201*	189723	SEAT; PVDF	4
	202*	109205	O-RING; PTFE	8
G	201*	194211	SEAT; Geolast®	4
	202*	109205	O-RING; PTFE	8

Ball Parts List (Matrix Column 5)

Digit	Ref. No.	Part No.	Description	Qty
1	301*	112088	BALL; PTFE	4
2	301*	112254	BALL; acetal	4
3	301*	103869	BALL; 316 stainless steel	4
4	301*	102973	BALL; 440C stainless steel	4
5	301*	112089	BALL; TPE	4
6	301*	112092	BALL; Santoprene®	4
7	301*	15B488	BALL; buna-N	4
8	301*	15B487	BALL; fluoroelastomer	4
G	301*	114751	BALL; Geolast®	4

Diaphragm Parts List (Matrix Column 6)

Digit	Ref. No.	Part No.	Description	Qty
1	401*	Not sold separately	DIAPHRAGM, backup; polychloropene (CR)	2
	402*	112181	PACKING, u-cup; nitrile	2
	403*	188605	DIAPHRAGM; PTFE	2
5	401*	188606	DIAPHRAGM; TPE	2
	402*	112181	PACKING, u-cup; nitrile	2
6	401*	188857	DIAPHRAGM; Santoprene®	2
	402*	112181	PACKING, u-cup; nitrile	2
7	401*	15B499	DIAPHRAGM; buna-N	2
	402*	112181	PACKING, u-cup; nitrile	2
8	401*	15B500	DIAPHRAGM; fluoroelastomer	2
	402*	112181	PACKING, u-cup; nitrile	2
G	401*	194212	DIAPHRAGM; Geolast®	2
	402*	112181	PACKING, u-cup; nitrile	2

* These parts are included in the pump repair kit, purchased separately. See Repair Kit Matrix on page 25 to determine the correct kit for your pump.

Torque Sequence

Always follow torque sequence when instructed to torque fasteners.

1. Left/Right Fluid Covers

Torque bolts to 130–150 in-lb (14–17 N•m)

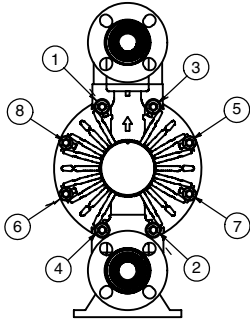

SIDE VIEW

3. Outlet Manifold

Torque bolts to 80–90 in-lb (9–10 N•m)

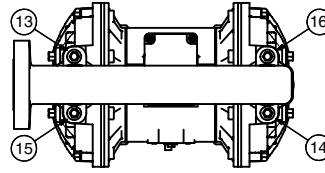

TOP VIEW

2. Inlet Manifold

Torque bolts to 80–90 in-lb (9–10 N•m)

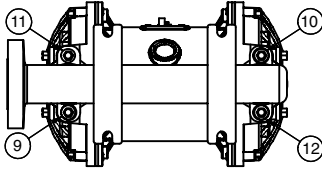

BOTTOM VIEW

Dimensional Drawings

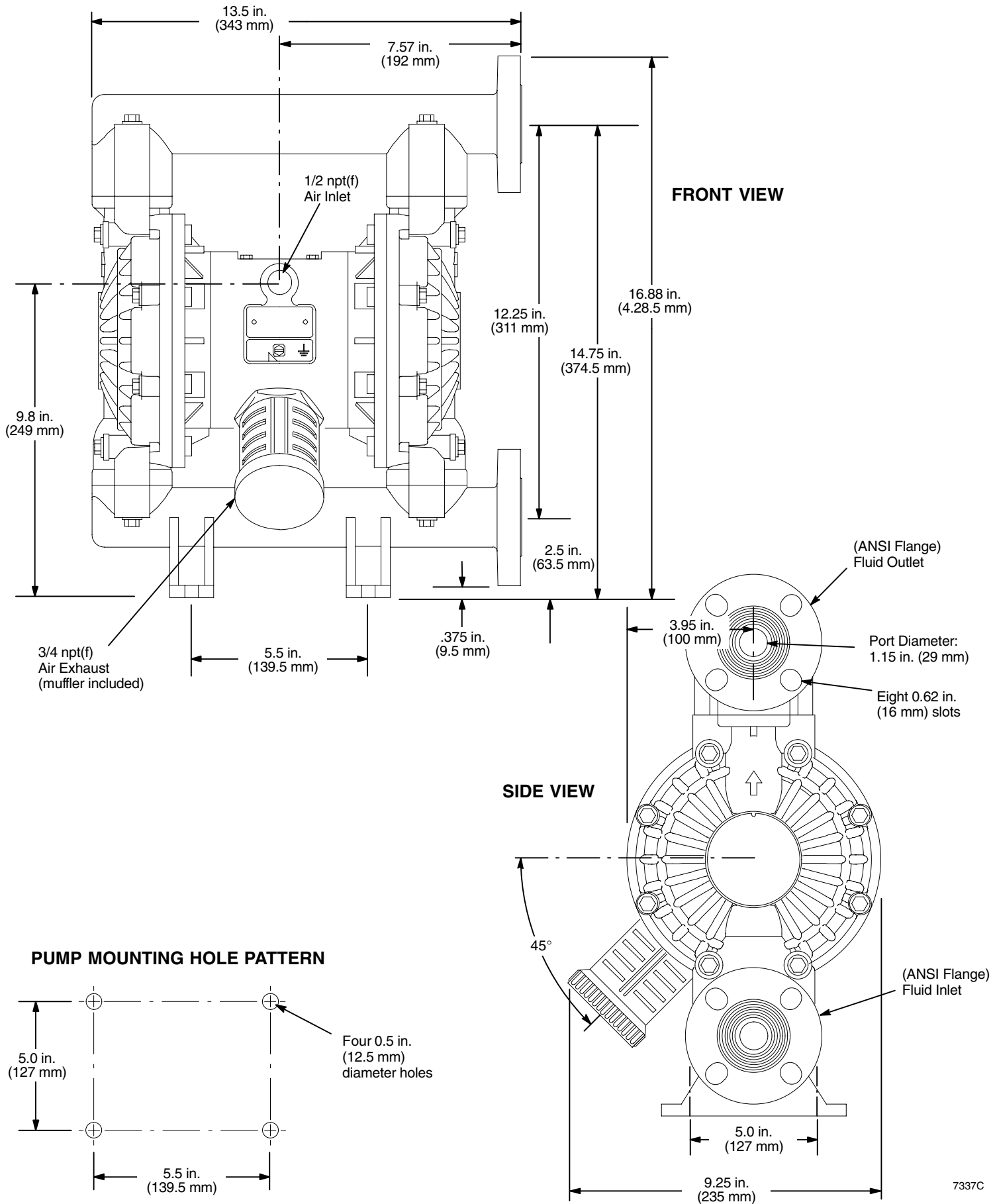

7337C

Technical Data

Maximum fluid working pressure 120 psi
(0.8 MPa, 8 bar)
Air pressure operating range 20 to 120 psi
(0.14 to 0.8 MPa, 1.4 to 8 bar)
Maximum air consumption 60 scfm
Air consumption at 70 psi/20 gpm 20 scfm (see chart)
Maximum free-flow delivery 42 gpm (159 l/min)
Maximum pump speed 276 cpm
Gallons (Liters) per cycle 0.15 (0.57)
Maximum suction lift 18 ft (5.48 m) wet or dry
Maximum Size pumpable solids 1/8 in. (3.2 mm)
* Maximum noise level at 100 psi, 50 cpm 89 dBa
Sound power level 100 dBa
* Noise level at 70 psi, 50 cycles/min: 78 dBa
Maximum operating temperature 150°F (65.5°C)
Air inlet size 1/2 npt(f)
Fluid inlet size. 1" Raised Face Flange
Fluid outlet size. 1" Raised Face Flange

Wetted parts Vary by Model. See pages 27 and 29
Non-wetted external parts aluminum, 302, 316 stainless steel
polyester (labels)
Weight (approximate) *Polypropylene Models*
..... *with aluminum center section: 19 lb (8.6 kg)*
..... *with stainless steel center section: 32 lb (14.6 kg)*
..... *Acetal Models*
..... *with aluminum center section: 22 lb (10 kg)*
..... *PVDF Models*
..... *with aluminum center section: 25 lb (11.3 kg)*
..... *with stainless steel center section: 35 lb (16 kg)*

Geolast® and Santoprene® are registered trademarks of the Monsanto Co.

Loctite® is a registered trademark of the Loctite Corporation.

* Noise levels measured with the pump mounted on the floor, using Rubber Foot Kit 236452. Sound power measured per ISO Standard 9216.

Performance Chart

Test Conditions: Pump tested in water with inlet submerged.

Fluid Pressure Curves

- A** at 120 psi (0.7 MPa, 7 bar) air pressure
- B** at 100 psi (0.7 MPa, 7 bar) air pressure
- C** at 70 psi (0.48 MPa, 4.8 bar) air pressure
- D** at 40 psi (0.28 MPa, 2.8 bar) air pressure

To find Fluid Outlet Pressure

(psi/MPa/bar) at a specific fluid flow (gpm/lpm) and operating air pressure (psi/MPa/bar):

1. Locate fluid flow rate along bottom of chart.
2. Follow vertical line up to intersection with selected fluid outlet pressure curve.
3. Follow left to scale to read fluid outlet pressure.

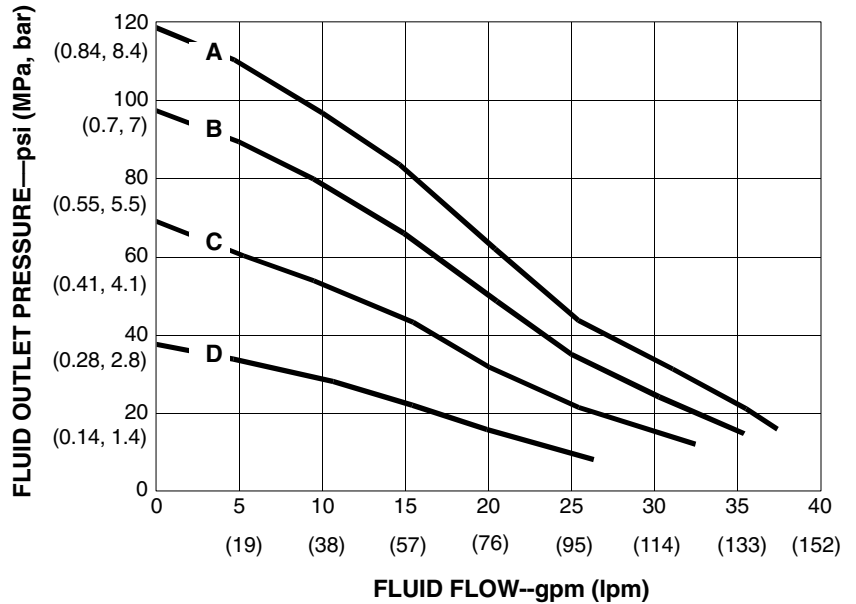

Air Consumption Curves

- A** at 120 psi (0.7 MPa, 7 bar) air pressure
- B** at 100 psi (0.7 MPa, 7 bar) air pressure
- C** at 70 psi (0.48 MPa, 4.8 bar) air pressure
- D** at 40 psi (0.28 MPa, 2.8 bar) air pressure

To find Pump Air Consumption (scfm or m³/min) at a specific fluid flow (gpm/lpm) and air pressure (psi/MPa/bar):

1. Locate fluid flow rate along bottom of chart.
2. Read vertical line up to intersection with selected air consumption curve.
3. Follow left to scale to read air consumption.

