



This manual contains important warnings and information.
READ AND RETAIN FOR REFERENCE

HUSKY™ 307, CART MOUNT, G700N AIR SPRAY GUN Heated Air Spray Package

See the Data Sheet, 305-667, for application information.

100 psi (6.9 bar) Maximum Fluid Working Pressure
100 psi (6.9 bar) Maximum Air Input Pressure

Model 237-410, Series A

This complete package includes a pump, G700N air spray gun with 0.055 in. (1.4 mm) fluid nozzle, cart, heater, 25-foot (7.6 m) air and fluid hoses, air and fluid controls, and fluid feed.

IMPORTANT

This manual provides the basic safety, installation, and operation information for the spray system. For your safety, also read the component manuals supplied with this system before you operate it.

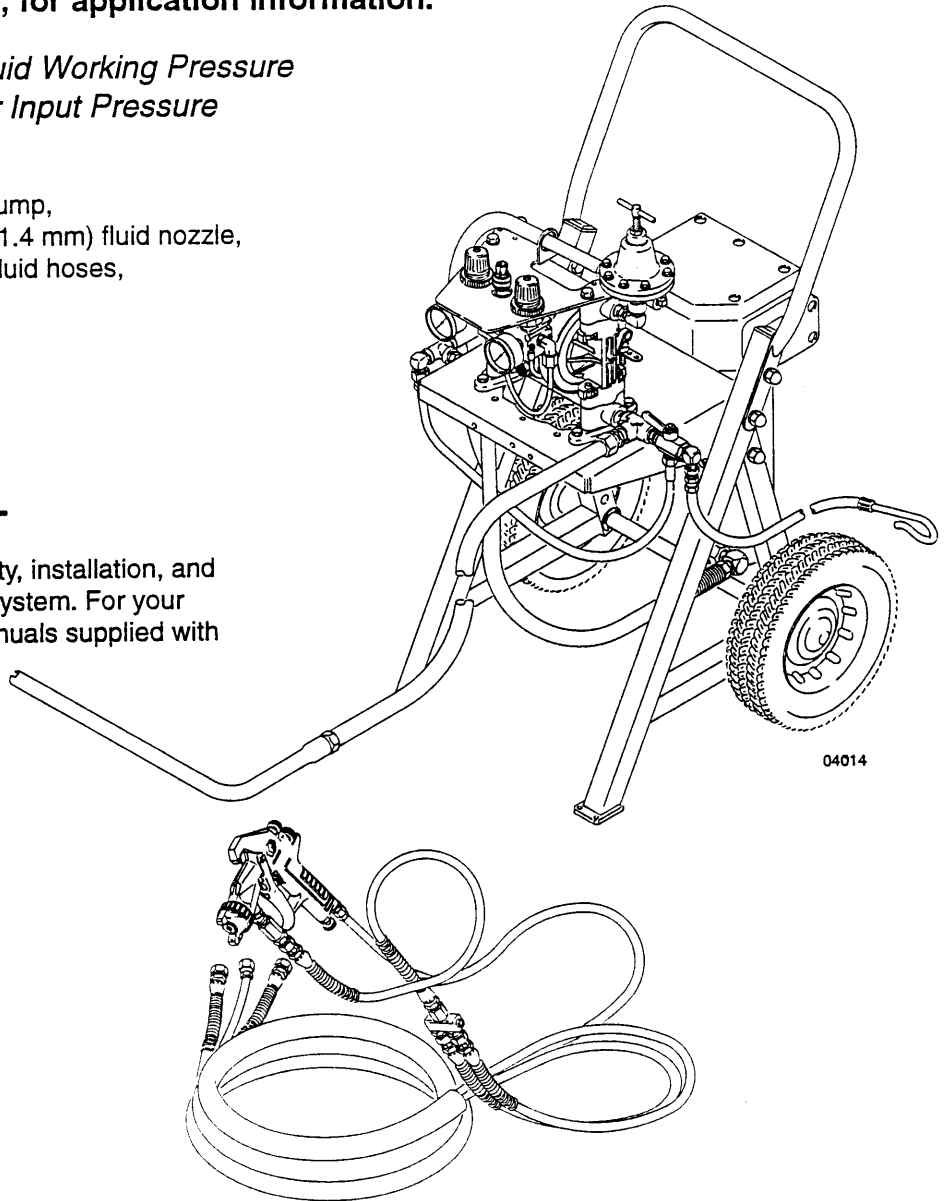

Parts Change Notice

Some parts in Rev. C of manual 308-448 have changed but have not yet been changed in the instruction manual. Please note the changes below and mark them in your manual or keep this sheet with your manual.

Assembly No.	Series Letter Change	Part That Changed	Ref No.	Part Description	Description of Change
Model 237-410	-	235-230	1	Husky 307 Pump	Replaced by Part No. D31-331 Husky 307 Pump, acetal with PTFE diaphragm and sst balls and seats. See manual 308-553 for parts.
		217-752	2	G700N Air Spray Gun	Replaced by Part No. 239-542 Delta Air Spray Gun, .055" orifice. See manual 308-742.
		224-044	17	Cart	Replaced by Part No. 238-938 Cart, which includes replaceable items 17a through 17j, listed below.
			17a	Front Bracket	Part No. 191-902. Qty: 1.
			17b	Capscrew	Part No. 108-768. Qty: 2.
			17c	Flat Washer	Part No. 108-788. Qty: 2.
			17d	Keps Nut	Part No. 113-761. Qty: 2.
			17e	Warning Label	Part No. 290-331. Qty: 1.
			17f	Wheel	Part No. 106-062. Qty: 2.
			17g	Hub	Part No. 104-811. Qty: 2.
			17h	Retaining Ring	Part No. 101-242. Qty: 2.
			17j	Tube Plug	Part No. 112-853. Qty: 2.
		100-021	36	Capscrew	Change quantity to 4.
		100-015	37	Nut	Change quantity to 4.
		100-016	38	Lockwasher	Change quantity to 4.
		208-536	42	Quick Disconnect	Change to Part No. 114-558.
		169-797	56	Nipple	Replaced by Part No. 191-872 Nipple, 1/4 npsm x 1/8 npt.
Added	67	Swivel	Add Part No. 157-705 Swivel, 1/4 npt(m) x 3/8 npsm(f), located between the fluid whip hose and the gun fluid inlet. Qty: 1.		



All written and visual data contained in this document reflects the latest product information available at the time of publication. Graco reserves the right to make changes at any time without notice.



Table of Contents

Warnings	2
Setup..	4
System Component Information	6
Operation	8
Flushing	10
Parts	12
Technical Data	16
Warranty..	16
Graco Phone Number	16

Symbols

Warning Symbol



This symbol alerts you to the possibility of serious injury or death if you do not follow the instructions.

Caution Symbol



This symbol alerts you to the possibility of damage to or destruction of equipment if you do not follow the instructions.

WARNING



PRESSURIZED FLUID HAZARD

Spray from the gun, hose leaks, or ruptured components can splash fluid in the eyes or on the skin and cause serious injury.

- Do not stop or deflect fluid leaks with your hand, body, glove, or rag.
- Follow the **Pressure relief procedure** on page 8 before cleaning, checking, or servicing the equipment.
- Tighten ail fluid connections before each use.
- Check the hoses, tubes, and couplings daily. Replace parts immediately if worn, damaged or loose. Permanently coupled hoses cannot be repaired.
- Handle and route hoses and tubes carefully. Keep the hoses and tubes away from moving parts and hot surfaces. Do not use the hoses to pull equipment. Do not expose Graco hoses to temperatures above 180°F (82°C) or below -40°F (-40°C).



FIRE AND EXPLOSION HAZARD

Improper grounding, poor air ventilation, open flames, or sparks can cause a hazardous condition and result in a fire or explosion and serious injury.

- Ground the equipment and the object being sprayed. See **Grounding the System** on page 5.
- If there is any static sparking while using the equipment, **stop spraying immediately**. Identify and correct the problem.
- Provide fresh air ventilation to avoid the buildup of flammable vapors from the solvent or the fluid being sprayed.
- Do not smoke in the spray area.
- Extinguish all open flames or pilot lights in the spray area.
- Do not turn on or off any light switch in the spray area.
- Electrically disconnect ail equipment in the spray area.
- Keep the spray area free of debris, including soivent, rags, and gasoline.
- Do not operate a gasoline engine in the spray area.

WARNING



INSTRUCTIONS

EQUIPMENT MISUSE HAZARD

Equipment misuse can cause the equipment to rupture, malfunction, or start unexpectedly and result in serious injury.

- This equipment is for professional use only.
- Read all instruction manuals, tags, and labels before operating the equipment.
- Use the equipment only for its intended purpose. If you are in doubt about this, call your Graco distributor.
- Do not alter or modify this equipment. Use only genuine Graco parts and accessories.
- Check equipment daily. Repair or replace worn or damaged parts immediately.
- Do not exceed the **100 psi (6.9 bar) maximum working pressure at 100 psi (6.9 bar) maximum incoming air pressure** of the package or the maximum working pressure of any accessory used with it.
- Do not move or lift pressurized equipment.
- Use fluids or solvents that are compatible with equipment wetted parts. **See the Technical Data** section of all equipment manuals. Read the fluid and solvent manufacturer's warnings.
- Fluid hoses must have spring guards on both ends to protect them from rupture caused by kinks or bends at or close to the couplings.
- Comply with all applicable local, state, and national fire, electrical, and other safety regulations.

TOXIC FLUID HAZARD

Improper handling of hazardous fluids or inhaling toxic fumes can cause extremely serious injury or death from splashing in the eyes, ingestion, or bodily contamination.

- Know the specific hazards of the fluid you are using.
- Store hazardous fluid in an approved container. Dispose hazardous fluid according to all local, state, and national guidelines.
- Wear appropriate clothing, gloves, eyewear, and respirator.
- If the pump diaphragm fails, hazardous fluid may be exhausted along with the air. See your separate pump manual for further information.

Setup

A CAUTION

This equipment is compatible with most water based materials. See the wetted parts in the **Technical Data** section and your fluid and solvent manufacturer's compatibility information.

Do not use catalyzed materials in heated applications.

2. Clear obstacles and debris that could cause an unsafe operating environment.
3. Bring an air line from your compressed air supply to the pump location. Be sure the air is dry and filtered. Install a bleed-type master air valve upstream from the pump. When it is closed and the pump air regulator (6a) is opened, the bleed-type master air valve relieves all air pressure to the system components.
4. Ventilate the spray booth.

I. Preparing the Operator

All persons who operate the system should be trained in the safe, efficient operation of all system components as well as the proper handling of the chemical coating. At a minimum, all operators should thoroughly read the safety, installation, and operation sections of this manual and the component manuals.

II. Preparing the Site

1. Use at least a 5 HP (3.7 Kw) air compressor for efficient operation.

! WARNING

To prevent hazardous concentrations of toxic and/or flammable vapors, spray only in a properly ventilated spray booth. **Never operate the spray gun unless ventilation fans are operating.**

Check and follow all of the national, state, and local codes regarding air exhaust velocity requirements.

KEY

Components you must supply:

- A Bleed-type master air valve
Required for pump; order part no. 11 O-223, 1/4" npt(f)
- B Air filter.
Order part no. 11 O-1 46, 1/4 npt(f)
- C Air supply line
- D Grounded 5 gallon metal pail
- E Air line moisture trap

Components supplied with package:

- 1 Husky 307 pump
- 2 G700N air spray gun
- 3 Fluid heater
- 6a Pump air regulator
- 6b Gun air regulator
- 10 Whip hose
- 13 Drain hose
- 42 1/4" female quick disconnect coupler
- 43 Pump ground wire
- 44 Fluid regulator
- 45 Fluid filter
- 48 Filter drain valve
- 54a Gun fluid hoses
- 54b Gun air hose
- 58 Tie strap

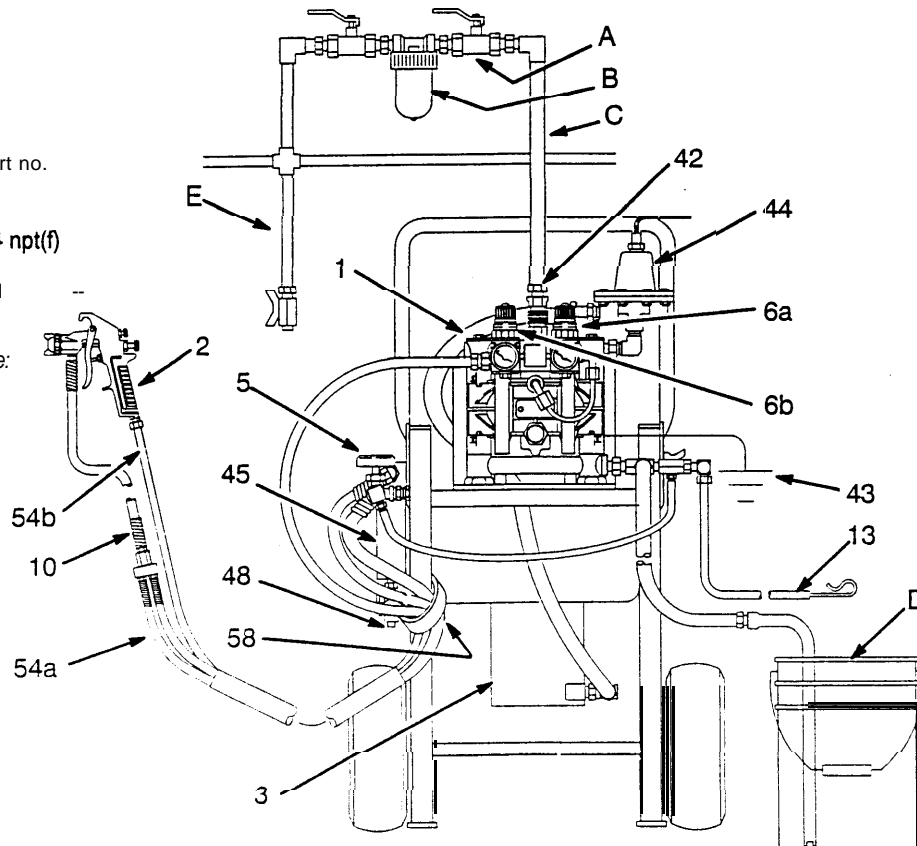

Fig. 1

04015



Setup

III. Unpacking the System

In addition to the assembled unit, these components are packed loosely or separately: suction assembly, hose set, gun, instruction manuals. These are the manuals you should receive:

308-I 94	Husky 307 pump
307-452	Air spray gun
308-325	Fluid regulator
307-805	Fluid heater
307-273	Fluid filter

IV. Connecting the Hose Set and Gun to the System See Fig. 1.

-  To fluid filter (45) outlet
-  To gun air regulator (6b) outlet
-  To needle valve (5) adapter (25)

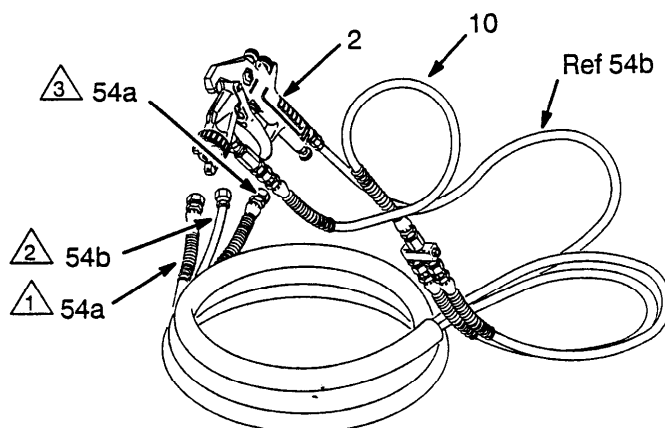

Fig. 2

1. Connect the air hose (54b) between the gun air regulator (6b) and the air inlet of the spray gun (2). This is a 1/4-18 swivel fitting.
2. Connect one fluid hose (54b) to the fluid filter (45) outlet. Connect the other fluid hose (54b) to the needle valve (5) adapter (25). The hose has a 1/4-18 swivel fitting.
3. Connect the whip hose (10) to the fluid inlet of the spray gun (2).
4. Verify that all fittings throughout the system are tightened securely.
5. Use a tie strap (58) to secure the hose set to the leg of the cart. This provides strain relief so that tugs on the heavy hoses don't damage the hose connections.

V. Grounding the System

WARNING

To reduce the risk of static sparking, ground the pump and all other equipment used or located in the spray area. Check your local electrical code for detailed grounding instructions for your area and type of equipment. Ground *all* of *this* equipment. Also read **FIRE OR EXPLOSION HAZARD** on page 2.

1. *Pump*: One end of the ground wire (43) is already connected to the pump grounding strip. Connect the clamp end of the ground wire to a true earth ground.
2. *Heater*: Plug into a properly grounded electrical outlet. If you use an extension cord, be sure it is a 3-wire grounded cord that is properly sized for the heater.
3. *Air compressor*. Follow manufacturer's recommendations.
4. *Object being sprayed*: Follow local code.
5. *Fluid supply container*: Follow local code.
6. *All solvent pails*: Follow local code. Use only metal pails, which are conductive. Do not place the pail on a non-conductive surface, such as paper or cardboard, which interrupts the grounding continuity.

System Component Information

VI. Using the G700N Air Spray Gun

Refer to Fig. 3.

1. Make initial fluid and air adjustments at the pump for maximum efficiency.
2. If you make adjustments at the gun, take note of what you do. Then, if the results are not satisfactory, you can easily return the gun to its previous adjustment. Steps 3 and 4 explain the gun adjustments.
3. Fan pattern adjusting valve (E). Normal adjustment is the valve turned out fully clockwise and then turned IN two full turns.
 - a. Turn *counterclockwise* to widen spray pattern.
 - b. Turn clockwise to narrow spray pattern.
4. Fluid adjusting valve (F). This valve is used in systems that do not have a fluid regulator. For this system, use the fluid regulator to adjust fluid flow.
5. The gun has a built-in lead and lag operation. When triggered, the gun emits air before the fluid is discharged. When the trigger is released, the fluid stops before the air flow stops. This helps assure the spray is atomized and prevents fluid buildup on the air cap.
6. Loosen the air cap retaining ring (G), and rotate the horns of the air cap to obtain the desired spray pattern. Tighten the retaining ring snugly, but do not over-tighten. See Fig. 4 for how to obtain a vertical or horizontal spray pattern.
7. Clean and lubricate the gun as instructed in the separate gun manual, 307-452.

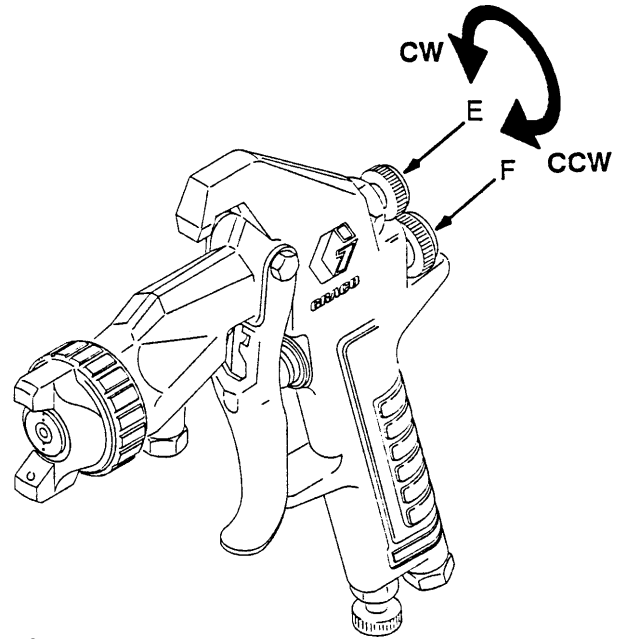

Fig. 3

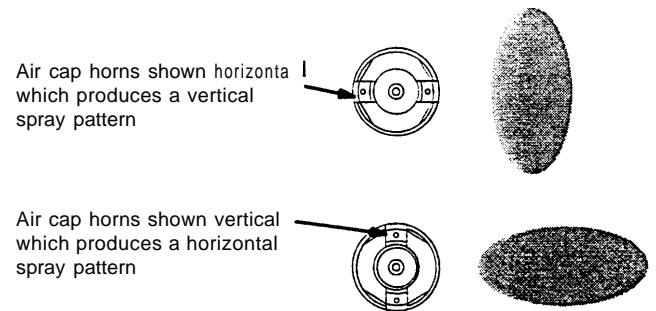

Fig. 4

VII. Using the Fluid Heater

See Fig. 6.

The heater (3) used in this system is a high mass heater. Always circulate the fluid when the heater is operating to prevent overheating and damaging the fluid. Do not use catalyzed material in this heater.

System Component Information

VIII. Using the Air Regulators and Needle Valve See Fig. 5.

1. Always open air and fluid regulators slowly to prevent surging during startup.

The air regulator (6a) on the right side of the pump controls air to the pump, and the regulator (6b) on the left side controls air to the gun.

2. To open the air regulator, pull out the adjusting knob. Turn the knob IN (clockwise) to open, and turn the knob fully OUT (counterclockwise) to close. You may push the adjusting knob in to lock the adjustment.
3. The fluid regulator (44) controls fluid from the pump to the gun. For an accurate setting, adjust the fluid regulator only when the gun is triggered, and fluid is flowing through the regulator. Be sure the jam nut (H) under the T-handle does not interfere with your adjustments. Tighten the jam nut to lock in the setting, if desired.
4. To open the fluid regulator, which allows fluid to flow, turn the T-handle IN (clockwise).
5. The needle valve (5), located on the fluid return side of the circulating system, acts as a flow control. Use it to balance the pressure of the circulating fluid so that the pump circulates a sufficient volume of fluid without running too fast or too slow. Trigger the gun while adjusting the needle valve. Turn the needle valve handle IN (clockwise) to restrict fluid and slow down the pump. Turn the needle valve handle OUT (counterclockwise) to allow more flow, which speeds up the pump.

A CAUTION

Never close the needle valve completely. Doing so prevents circulation, which can cause the fluid to overheat, damaging the fluid and the heater.

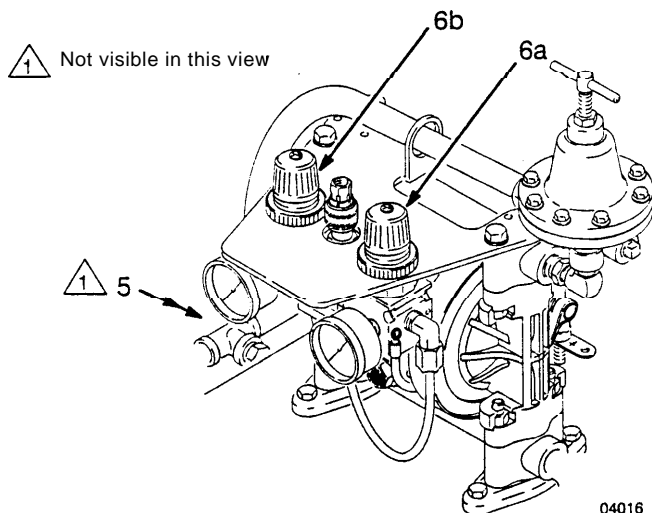

Fig. 5

04016

IX. Using the 3-Way Valve See Fig. 6.

See Fig. 6.

Heated systems require that the fluid circulate constantly when the heater is turned on. The 3-way valve (9) supplied with this system enables you to drain or circulate the fluid. The words **Drain** and **Circulate** are marked on the valve.

1. In the **Drain** position, and with the gun untriggered, the fluid returns from the gun, to the needle valve (5), to the hose (12), and to the 3-way valve, which directs the fluid out the drain hose (13). This position is used when flushing the system and when relieving system pressure.
2. In the **Circulate** position, with the gun untriggered, fluid returns from the gun, to the needle valve (5), to the hose (12), and to the 3-way valve, which directs the fluid back into the pump intake. This position is used during normal operation, and it helps keep the fluid at a constant temperature.

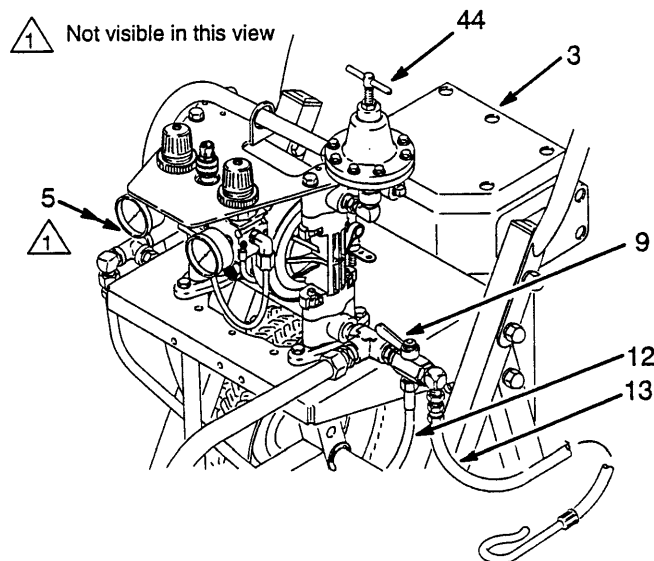

Fig. 6

Operation

I. Pressure Relief Procedure

⚠ WARNING

The system remains pressurized until pressure is manually relieved. To reduce the risk of serious injury from pressurized fluid, accidental spray from the gun, or splashing of any fluid, follow this procedure whenever you

- Are instructed to relieve pressure
- Stop spraying
- Check or service any system equipment
- Install, clean, or change spray nozzles

1. Be sure the pump air regulator (6a) is still open. Close the master air valve (A) to relieve pump air pressure.
2. Close both air regulators (6a,6b).
3. Turn the 3-way valve (9) to **Drain**.
4. Trigger the spray gun into a waste pail to relieve fluid pressure.
5. Turn off and unplug the heater (3).

II. Flush the Pump Before First Use

Flush with a solvent compatible to your fluid. Consult the fluid manufacturer's literature for recommendations. See **Flushing** on page IO.

III. Priming the System

See Fig. 7.

1. Put the suction tube (15) in the prepared fluid.

KEY

- | | |
|-----|-----------------------------|
| A | Bleed-type master air valve |
| C | Air line |
| 3 | fluid heater |
| 6 a | Pump air regulator |
| 6 b | Gun air regulator |
| 9 | 3-way valve |
| 13 | Drain hose |
| 44' | Fluid regulator |
| 48 | Filter drain valve |

2. Hook the drain hose (13) on the waste pail.
3. Close the filter drain valve (48).
4. Turn the 3-way valve (9) to **Drain**.
5. Open the fluid pressure regulator (44) (fully clockwise).
6. Turn the needle valve (5) all the way out (counterclockwise)
7. Close the gun and pump air regulators (6a,6b) (full counterclockwise).
8. Connect the air line (C) to the pump.
9. Open the master air valves (A).
10. Slowly raise the pump air regulator (6a) pressure to 20 to 30 psi (1.4 to 2.1 bar). The pump will cycle quickly until it is primed. When it is primed, the pump will stall against pressure. Now set the pump air pressure to 40 psi (2.8 bar). When fluid flows from the drain hose, turn the 3-way valve to **Circulate**.
11. Hold the gun against and aimed into a grounded metal waste pail. Trigger the gun, and slowly open the fluid regulator (44). The gun will emit air until the fluid arrives. When fluid flows freely, release the gun trigger.

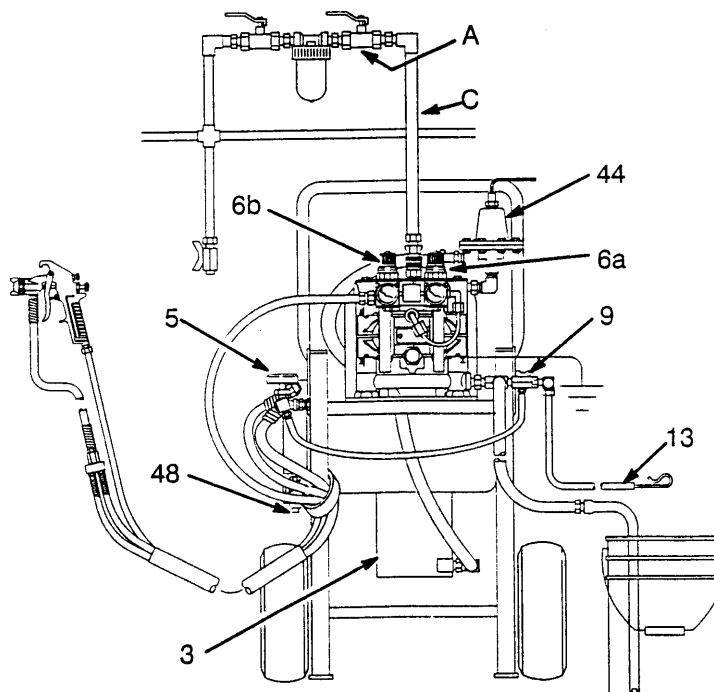

Fig. 7
a 308-448

Operation

12. Adjust the needle valve to set the pump cycle rate at 1 stroke every 15 seconds.
13. Turn the heater dial to 3. Whenever the heater setting is changed, allow the fluid to circulate and stabilize before checking the temperature (about 10 minutes) .

A CAUTION

Be sure the fluid is circulating whenever the heater is on to reduce the risk of damage to the fluid or the heater.

14. Follow the fluid manufacturer's recommendations for temperature, and adjust the heater accordingly. If unknown, set the temperature to 110°F (43°C) at the outlet thermometer. Do not proceed until the temperature has stabilized. Do not allow the fluid to exceed **140°F (60°C)** unless your fluid manufacturer recommends higher temperatures.
15. Spray fluid into a waste pail for about 10 seconds to bring heated material to the gun.
16. Hook the drain hose (13) on the fluid supply pail.

IV. Setting Fluid and Air Pressure

1. With the system primed, the gun regulator (6b) closed, and the pump air regulator (6a) set as instructed in Step 10 on page 8, adjust the fluid pressure regulator (44) to the fluid manufacturer's specifications, if available. Otherwise, follow Step 2 to determine the fluid pressure setting.
2. To determine the fluid pressure setting, hold the gun parallel to the floor. (Be sure to catch the fluid in a container.) With the gun air pressure turned OFF, trigger the gun. Adjust the fluid pressure regulator (4) until the straight fluid stream is within the range indicated for the viscosity of your fluid before it drops off. See Fig. 8. Make note of the pressure on the fluid gauge it is your optimal fluid pressure setting.

Fluid Viscosity

Measured with #2 Zahn cup

- Light (18-25 seconds)
- Medium (25-40 seconds)
- Heavy (40-60 seconds)

Fluid Droop

- 8-10" (200-250 mm)
- 6-8" (150-200 mm)
- 4-6" (100-150 mm)

 Fluid droop: straight stream before dropping off

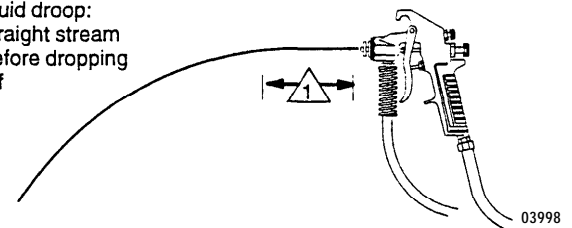

Fig. 8

3. Be sure the gun's fan pattern adjusting valve (E) has been turned OUT fully clockwise and then turned IN two full turns. See Fig. 9.

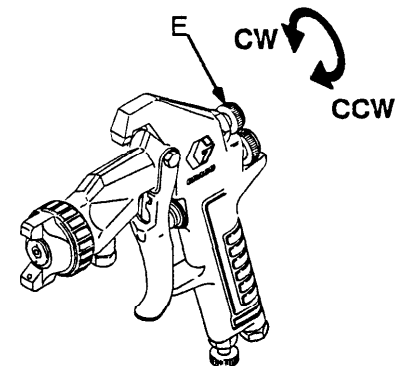



Fig. 9

4. Release the trigger. Install the air cap.
5. Partially trigger the gun so only air is emitted. Set the gun air regulator (6b) pressure to 60 psi (4.2 bar) 70 psi (4.9 bar).
6. Spray a stationary test pattern on scrap paper. Hold the gun 10 to 12 in. (250 to 300 mm) from the paper, and spray for 2 or 3 seconds. If the spray pattern is poorly atomized, you may need to adjust the air or fluid pressure.

If the spray pattern atomization is not fine enough, increase the gun air pressure. If the spray pattern atomization is too fine, decrease the gun air pressure. If the atomization is still not good enough, try lowering the fluid pressure in increments of 2 or 3 psi to achieve the desired finish quality.

NOTE: For the most efficient paint usage, use the lowest air pressure needed to obtain a good finish. Higher air pressures create more overspray and uses more fluid.

7. Adjust the fan pattern adjusting valve (E) to tune the spray pattern. Turn *counterclockwise* to widen spray pattern. Turn *clockwise* to narrow spray pattern. See Fig. 9. 

Operation

V. Production Spraying

You are now ready for production spraying. If you stop spraying for more than 30 minutes, turn off the heater to prevent overheating the fluid.

VI. Shutting Down the System

Shut down the system at the end of the work shift and before checking, adjusting, cleaning, or repairing the system. Always follow the **Pressure Relief Procedure** on page 8.

Flushing

I. When to Flush

- Before the first use
- When changing colors
- Before fluid can dry or settle out in a dormant system
- Before storing the system

II. How to Flush

See Fig. 10.

WARNING

Before you flush, be sure the heater is turned off and the fluid has cooled. This is to reduce the risk of a fire or explosion and serious injury.

1. Turn off the heater (3), and allow the system to cool.
2. Remove the air cap from the gun, and clean separately. Do not reinstall at this time.
3. Open the filter drain valve (48). Unscrew the fluid filter (45) bowl. Remove the screen. See manual '307-273. Reinstall the bowl without the screen.
4. Hook the drain hose (13) on the waste pail.
5. Turn the 3-way valve (9) to **Drain**.
6. Turn the needle valve (5) all the way out (counterclockwise).
7. Put the suction tube (15) in a grounded pail with about 1 gallon (4 liter) of a compatible solvent.
8. Make sure the air regulators (6a,6b) and master air valves (A) are closed.
9. Make sure the fluid regulator (44) is open (turned in) to allow fluid flow.
10. Connect the air line (C) to the pump.
11. Open the master air valves (A).
12. Slowly open the pump air regulator (6b) until the pump starts.
13. Hold the gun against a grounded metal waste pail. Trigger the gun slowly. The gun will emit air until the fluid arrives. When solvent appears, release the trigger.

Flushing

14. For a first-time flush, trigger the gun, and circulate the solvent for 20 seconds.

For flushing after spraying fluid, turn the 3-way valve to **Circulate**. Trigger the gun periodically while circulating the solvent. Periodically turn the 3-way valve to **Drain** to flush out some dirty solvent. Flush until the system is clean. Repeat with clean solvent, if necessary.

15. Raise the suction tube out of the solvent, trigger the gun, and run the pump until air comes from the gun. Turn the 3-way valve to **Drain**, and run the pump until all air is expelled.

16. Release the trigger, and close the fluid regulator (44) and the air regulators (6a,6b).

17. Clean the filter screen, air cap, and fluid nozzle separately.

18. Open the filter drain valve (48). Remove the filter bowl, and reinstall the filter screen.

19. Thoroughly clean the inside and outside of the suction tube.

20. You are now ready to prime the system with another fluid or to store the system.

KEY

A	Bleed-type master air valve
C	Air line
3	Fluid heater
6a	Pump air regulator
6b	Gun air regulator
9	3-way valve
13	Drain hose
44	Fluid regulator
45	Fluid filter
48	Filter drain valve

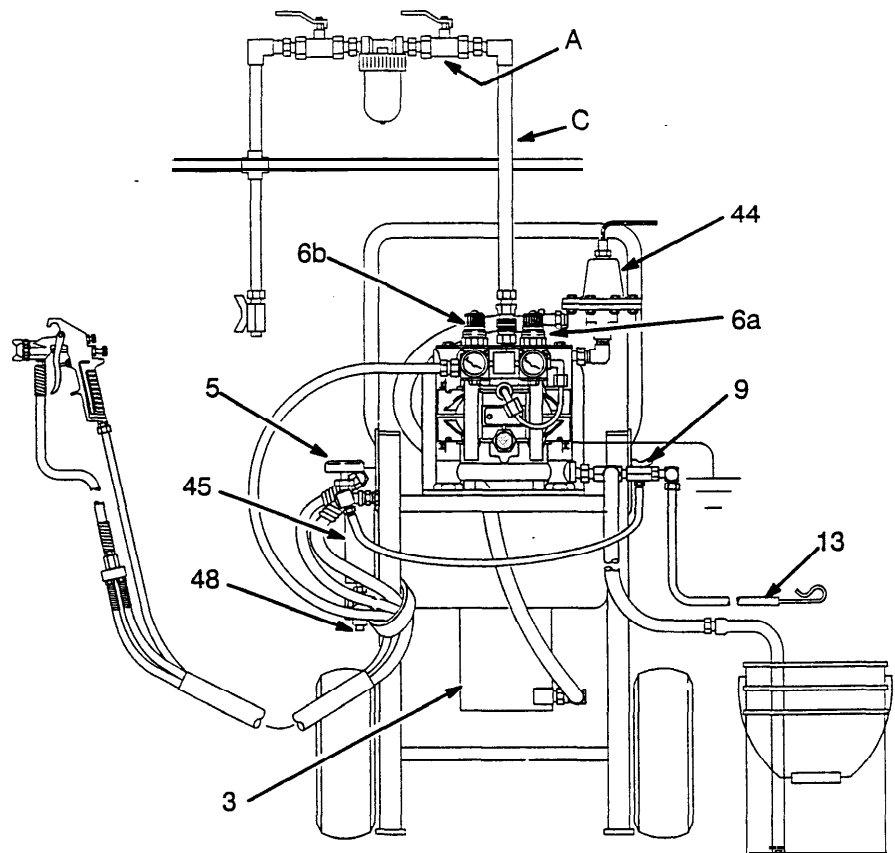

Fig. 10

04015

Parts

Model 237410, Series A

Ref No.	Part No.	Description Qty.	Ref. No.	Part No.	Description	Qty.
1	235-230	HUSKY 307 PUMP, Acetal/PTFE See 308-I 94 for parts	1	25	100-840	90° ELBOW, street, 1/4 npt (m x f)
2	217-752	G700N AIR SPRAY GUN with 106-706 air cap and O/ON needle, see manual 307-452	1	26	111-805	BLOCK, diverter
3	220-522	VISCON2 HEATER (120V) See 307-805 for parts	1	28	188-093	BRACKET, air regulator
4	110-160	CORD ASSY, heater, 12 AWG, 600V, 20 AMP, 105°C (221 °F), 6.5' (2 m) long	1	29	169-971	AIR LINE FITTING, 3/8 npt(m)
5	108-233	NEEDLE VALVE	1	30	103-473	STRAP
6	111-804	AIR REGULATOR, 0 to 125 psi (0 to 8.5 bar) pressure range	2	31	155-494	90° SWIVEL UNION, 3/8 npsm(f) x 3/8 npt(m) swivel
7	11 O-209	NUT, regulator	2	32	101-754	PLUG, pipe, 3/8 npt
8	108-I 90	AIR PRESSURE GAUGE, 0 to 100 psi (0 to 7 bar)	2	33	107-219	BUSHING, 3/4 npt(m) x 1/2 npt(f)
9	214-711	3-WAY BALL VALVE, 1/4 npt(m), See 306-861 for parts	1	34	100-639	WASHER, wrought, 1/4"
10	214-699	WHIP HOSE, cpId 1/4 npsm(fbe) swivel, 3/1 6" ID x 6' (4.8 mm ID x 1.8 m) long	1	35	108-290	SCREW
11	205-I 69	FLUID HOSE, 3/8" npt, spring (fbe) guards both ends, 3' (0.9 m) long	1	36	100-021	CAPSCREW, 1/4-20 uric-2a x 1"
12	206-966	HOSE, 1/4-1 8 npsm(fbe) 1.5' (.45 m) long	1	37	100-015	NUT, 1/4-20 uric-2a
13	206-965	DRAIN HOSE ASSEMBLY 3' (0.9 m) long	1	38	100-016	LOCKWASHER, spring, 1/4"
14	188-I 73	FLUID SUCTION HOSE, 3/4" ID x 3.5' (19 mm ID x 1.06 m)	1	40▲	187-732	WARNING LABEL
15	165-767	SUCTION TUBE, 3/4 npt(f)	1	41	188-I 74	IDENTIFICATION LABEL
16	188-I 07	AIR INLET TUBE, 0.25" OD x 0.170" ID x 6" (6.3 mm OD x 4.3 mm ID x 152 mm)	1	42	208-536	QUICK DISCONNECT, female
17	224-044	CART See 308-I 36 for parts	1	43	222-011	GROUND WIRE
18	156-849	NIPPLE, 3/8-18 npt	1	44	236-216	REGULATOR; 1/4" npt x 3
19	188-077	NIPPLE, 1/4-18 npt x 1/4-8.6 sf, cst	1	45	218-029	FLUID FILTER see 307-273 for parts
20	803-088	TEE	1	46	100-I 76	BUSHING, 3/8 to 1/4 npt
21	162-453	NIPPLE, 1/4 npt x 1/4 npsm	1	47	11 O-249	ELBOW, 1/4 npt mbe
22	111-807	90° TUBE FITTING ELBOW, 1/4 npt(m) x ferrule nut for 0.25" (6.3 mm) OD tube	2	48	210-658	BALL VALVE
23	158-683	90° ELBOW, 1/2 npt (m x f)	1	49	176455	FLUID PRESSURE GAUGE 0 to 100 psi (0 to 6.9 bar) range
24	112-408	90° CORD GRIP ELBOW, 1/2 npt(m), includes nut, washer, and grommet	1	50	104-984	TEE, 1/4 npt(f)
				51	156-953	STUD
				52	100-509	PLUG, 1/4"
				53	223-324	GROUND WIRE
				54	237494	FLUID HOSE SET, includes: two fluid hoses, one air hose and hose insulator
				54a		
				54b		
				55	100-307	NUT
				56	169-797	NIPPLE, 1/4 npsm x 1/8 npt
				57	169-795	MANIFOLD, 1/8 npt(f)
				58	100-I 39	PLUG, hex socket, 1/8 npt
				60	159-239	NIPPLE; 3/8" x 1/2"
				61	102-790	SCREW
				62	165-I 98	NIPPLE; 1/4" x 3/8"
				63	111-864	CONNECTOR, male
				64	100-505	BUSHING
				66	156-971	NIPPLE, short

Use only **genuine Graco parts and accessories.**

▲ Replacement Danger and Warning labels, tags, and cards are available at no cost.

Parts

Model 237410, Series A

