

Gelcoat Dispense Systems

Low-Emission Gelcoat Systems for the Composites Industry



Outstanding performance for gelcoat applications

Designed for smooth, accurate gelcoat application, GlasCraft Gelcoat Dispense Systems are engineered to deliver reliable performance. Built with fewer wear items, GlasCraft equipment consumes fewer replacement parts. With reduced service expenses and less revenue lost due to downtime, GlasCraft's Gelcoat Systems are highly economical to own and operate.

GlasCraft Gel-Coat Systems:

- Dispense pigmented, tooling, low-VOC and specialty gelcoats
- Offer reliable, highly accurate catalyst percentage
- Provide high-efficiency performance at low spraying pressures
- Available in internal and external mix configurations

Typical applications:

- Marine and watercraft
- Pool and spa
- Bathware
- Transportation
- Cultured marble

Dual Upper Seals on Catalyst Pump

- Dual seal prevents leakage – any weepage past the primary seal is returned to the catalyst reservoir, not on the floor

Secondary shaft seal

Primary shaft seal

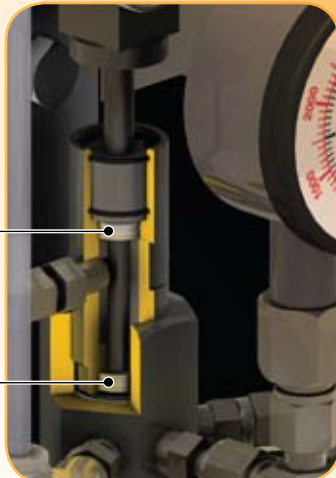

Long-life Design

- Triple-lip spring-loaded seals and hardened cylinders, seats and valves provide long wear life

GlasCraft INDY X Gelcoat Dispense System

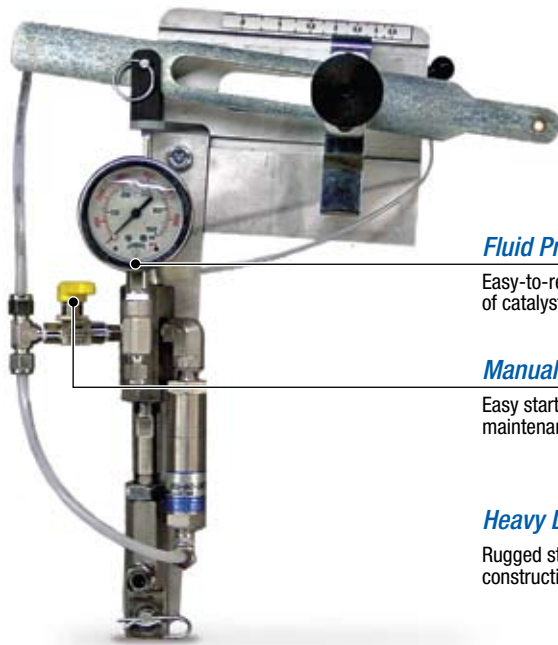

Fluid Pressure Gauge

Easy-to-read gauge for verification of catalyst fluid flow

Manual Relief Valve

Easy startup, shut down and maintenance

Heavy Duty

Rugged stainless steel construction

Adjustable-Ratio Catalyst Pump

- Allow for infinite adjustment of catalyst percentage – no tools required
- Ensures proper catalyst percentage and optimal results
- Operates at any desired catalyst percentage
 - 0.5% to 3.5% for 11:1 system
 - 0.5% to 2.9% for 17:1 system
 - 0.8% to 5.6% for 20:1 system
 - 1.5% to 8.2% for 13:1 G2 system



Precision Air Pilot Valve

Allows fast pneumatic changeover without any parts to wear out

Surge Bottle Accumulator

Compensates for pressure spikes

Quick Change Seal Design

- Tool-less quick disconnect allows for easy top seal maintenance
- Lower end is easily removed to service lower seals on pump

Four-inch Stroke

Uses fewer cycles, which means less wear and increased uptime

Gelcoat Pump

- Reliable, low-maintenance reciprocating piston pump for moving pigmented, tooling, low-VOC and specialty gelcoats
- Piston pump works well with fillers
- Standard pump offers 11:1 ratio
- Develops up to 1300 psi (89 bar, 8.9 MPa)
- Delivers up to 2.5 gpm (9.5 lpm)

Optional resin pumps:

HVRP 17:1 pump

- Designed for high volume gelcoat or polyester resin applications
- Ideal for high volume production shops
- Develops up to 1700 psi (117 bar, 11.7 MPa)
- Delivers up to 4.1 gpm (15.5 lpm)

20:1 pump

- For high-viscosity materials
- Develops up to 2000 psi (138 bar, 13.8 MPa)
- Delivers up to 1.6 gpm (6.0 lpm)

Air Assist Containment

Advanced technology to control and contain your spray pattern

When you buy a drum of resin or gelcoat, you pay for every drop of material. It makes good economic sense to put as many of those drops as possible on the mold.

GlasCraft's exclusive Air Assist Containment (AAC) wraps the spray pattern in a containment shield of air – preventing atomized droplets from escaping the spray pattern. Droplets that escape and end up on the floor, wall or employee's clothing are a waste of money.

AAC creates a spray pattern where the droplets travel to the mold at very low pressure. The low speed or "particle velocity" creates very little turbulence or disturbance in the liquid when the droplet makes contact with the mold. Competitive spray guns with higher "particle velocity" create a great deal of turbulence when the droplets impact the mold. Turbulence creates air entrapment which results in porosity. AAC spraying dramatically reduces the chances of air entrapment and porosity.

AAC improves your profit picture

- All GlasCraft external mix spray guns feature the patented AAC technology
- Reduces material waste – which results in more molds gelcoated per drum of material
- Precise catalyst delivery and reduced particle velocity assure the highest quality finish
- Less overspray means a healthier work area for employees

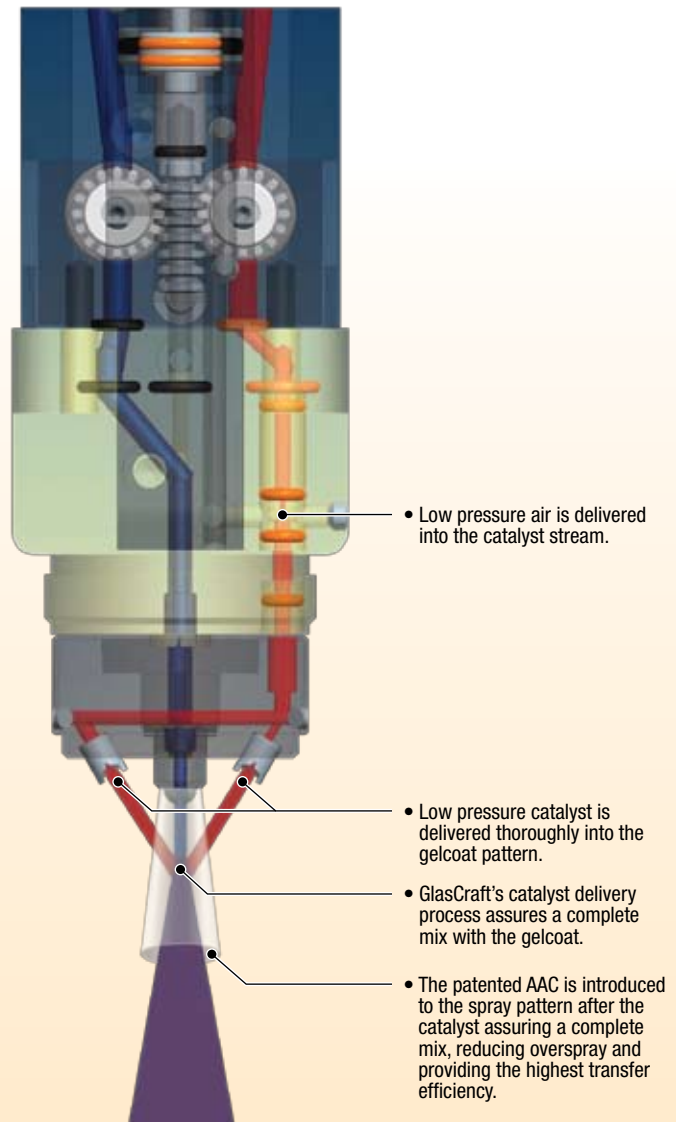
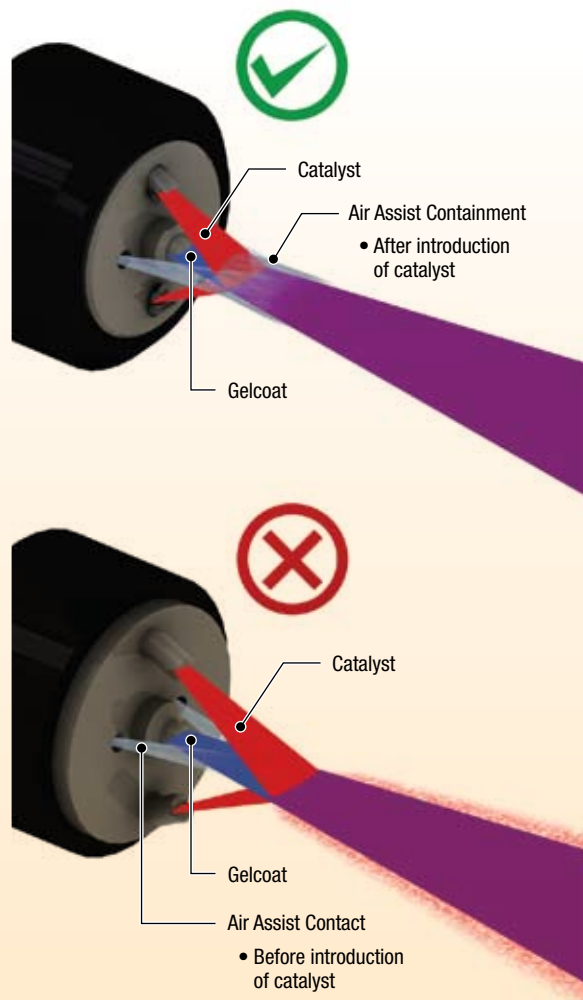

GlasCraft Gelcoat Spray Guns

Uniform spray pattern

GlasCraft's Gelcoat guns feature the patented AAC feature to produce the most uniform and consistent low-emission spray pattern with stabilizing air streams.

Formula Guns

- Air-actuated trigger provides immediate response, virtually eliminating hot and cold spots
- No-needle design eliminates needle adjustments
- Special hardened valves are engineered for today's low VOC formulations
- Fluid control occurs via air-operated piston that opens and closes internal ball valves
- Easy access to valve packings for quick maintenance and increased uptime
- Feature AAC technology for uniform spray pattern with minimal overspray



Formula Internal Mix Gun

- Precision check valves automatically balance fluid pressures
- Extended mix area results in the best mix



Formula X External Mix Gun

- Unique catalyst delivery assures complete integration to the gelcoat spray pattern
- Easy visual verification of catalyst flow
- No solvent needed to flush

INDy Spray Guns

- Volume control assures the highest quality finish with minimal porosity
- Simple material valve and seat design is easy to maintain, resulting in increased uptime
- Features AAC for excellent pattern control and less wasted material
- Ergonomic, lightweight design reduces operator fatigue



INDy Internal Mix Gun

- Fully adjustable pattern control and precision check valves to automatically balance fluid pressures
- Extended mix area results in the best mix



INDy X External Mix Gun

- Unique catalyst delivery assures complete integration to the gelcoat spray pattern
- No solvent needed to flush

What's the difference between external and internal mix guns?

External mix guns:

- Ideal for gelcoat applications
- Chemical is mixed outside the gun
- Operators can see the catalyst being added to the mix
- Does not require a solvent flush

Internal mix guns:

- Ideal for chopper and wet-out systems
- Ensures the best possible mix
- Requires a solvent flush for maintenance

GlasCraft Multiple Color Gelcoat System

- Ideal for applications that require numerous gelcoat colors or continuous change of colors
- Quick, efficient color changes reduce downtime
- The standard two-color system can be expanded with additional colors by adding optional fluid section kits
- Flexible design lets you use one system for both resin and gelcoat dispensing



GlasCraft G2-SSP Gelcoat System

- Designed to deliver outstanding performance in an economical package
- Along with the INDy X Gun, the G2-SSP provides the industry's best spray pattern with the highest transfer efficiency
- INDy X gun is standard
- Optional Formula X gun is available
- 13:1 External mix only
- Delivered fully assembled

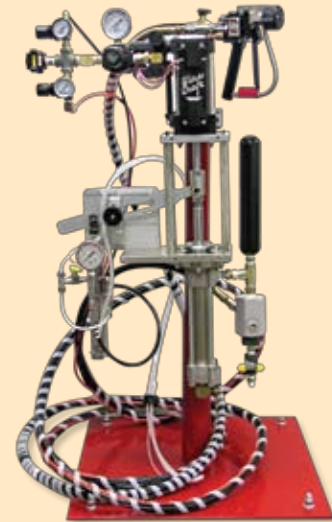

Technical Specifications

	G2-SSP	INDy/Formula 11:1 or MCG 11:1	INDy/Formula 20:1 or MCG 20:1	HVRP 17:1
Air requirement	15 cfm @ max output (425 lpm @ 6.8 bar)	35 cfm @ max output (480 lpm @ 6.8 bar)	35 cfm @ max output (480 lpm @ 6.8 bar)	80 cfm @ max output (620 lpm @ 6.8 bar)
Material pump capacity*	1 gpm (3.79 lpm)	2.5 gpm (9.5 lpm)	1.6 gpm (6.0 lpm)	4.1 gpm (15.5 lpm)
Material pump output	.021 gal per cycle; 50 cycles = 1 gal; 13 cycles = 1 liter	.050 gal per cycle; 20 cycles = 1 gal; 5 cycles = 1 liter	.032 gal per cycle; 31 cycles = 1 gal; 8 cycles = 1 liter	.082 gal per cycle; 12 cycles = 1 gal; 3 cycles = 1 liter
Catalyst slave pump range	1.5% to 8.2%	0.5% to 3.5%	0.8% to 5.6%	0.5% to 2.9%

* Material pump capacity is based on 50 cycles per minute. Higher cycle rates can be achieved depending on material viscosity, material temperature and volume of air. All pump outputs are measured at the pump outlet using water as the test media.

ACCESSORIES – SPRAY TIPS

Part Number	Orifice	Part Number	Orifice	Part Number	Orifice
23005-C4	0.04	23005-M5	0.05	LPA2-147-2325	0.023
23005-C5	0.05	23005-M6	0.06	LPA2-147-2340	0.023
23005-C6	0.06	23005-P4	0.04	LPA2-147-2350	0.023
23005-C7	0.07	23005-TC6	0.06	LPA2-147-2365	0.023
23005-C8	0.08	23005-TC7	0.07	LPA2-147-2625	0.026
23005-C9	0.09	23005-TC8	0.08	LPA2-147-2640	0.026
23005-E4	0.04	23005-TE7	0.07	LPA2-147-2650	0.026
23005-E5	0.05	23005-TG7	0.07	LPA2-147-2665	0.026
23005-E6	0.06	23047-J1	0.012	LPA2-147-3125	0.031
23005-E7	0.07	23047-J2	0.014	LPA2-147-3140	0.031
23005-E8	0.08	23047-J3	0.022	LPA2-147-3150	0.031
23005-E9	0.09	23047-M1	0.012	LPA2-147-3165	0.031
23005-G4	0.04	23047-M2	0.014	LPA2-147-3625	0.036
23005-G5	0.05	23047-M3	0.022	LPA2-147-3640	0.036
23005-G6	0.06	23047-N1	0.012	LPA2-147-3650	0.036
23005-G7	0.07	23047-N2	0.014	LPA2-147-3840	0.038
23005-G8	0.08	23047-N3	0.022	LPA2-147-3850	0.038
23005-G9	0.09	23047-P1	0.012	LPA2-147-4325	0.043
23005-J4	0.04	23047-P2	0.014	LPA2-147-4340	0.043
23005-J5	0.05	23047-P3	0.022	LPA2-147-4350	0.043
23005-J6	0.06	LPA2-147-1525	0.015	LPA2-147-4365	0.043
23005-J7	0.07	LPA2-147-1540	0.015	LPA2-147-5225	0.052
23005-J8	0.08	LPA2-147-1550	0.015	LPA2-147-5240	0.052
23005-J9	0.09	LPA2-147-1565	0.015	LPA2-147-5250	0.052
23005-K3	0.04	LPA2-147-1825	0.018	LPA2-147-5265	0.052
23005-K4	0.04	LPA2-147-1840	0.018	LPA2-147-6225	0.062
23005-K5	0.05	LPA2-147-1850	0.018	LPA2-147-6240	0.062
23005-K6	0.06	LPA2-147-1865	0.018	LPA2-147-6250	0.062
23005-K7	0.07	LPA2-147-2125	0.021	LPA2-147-6265	0.062
23005-K8	0.08	LPA2-147-2140	0.021	LPA2-147-7240	0.072
23005-K9	0.09	LPA2-147-2150	0.021	LPA2-147-7250	0.072
23005-M4	0.04	LPA2-147-2165	0.021	LPA2-147-7840	0.078

PFR OPTION

Part Number	Item
20335-XX	Roller cover
20335-01	Roller cover, 9 in x ½ in nap
20335-02	Roller cover, 9 in x ¾ in nap
20335-03	Roller cover, 12 in x ½ in nap
20335-04	Roller cover, 9 in x ¾ in nap
20335-05	Roller cover, 18 in x ½ in nap
20335-06	Roller cover, 18 in x ¾ in nap
20337-XX	Pole extension assembly
20337-01	Pole extension assembly, 1.5 ft (0.5 m)
20337-02	Pole extension assembly, 3 ft (0.9 m)
20337-03	Pole extension assembly, 6 ft (1.8 m)
22275-00	PFR adapter fitting
22276-00	PFR swivel fitting
22277-00	Gun roller adapter kit
22912-XX	Pressure roller assembly
22912-01	Pressure roller assembly, 9 in (23 cm)
22912-02	Pressure roller assembly, 12 in (30 cm)
23003-00	Spray tip spacer
23550-00	INDy Gun
23750-00	Formula Gun Assembly

Formula/INDy Screw on AAC Gun Head Kit

23570-00 Internal Mix Gel - Screw on AAC Gun Head Kit
 NOTE: P/N 23570 requires a regulator assembly which is not included in the kit. The following must be ordered for a complete regulator assembly.

Regulator Assembly

3165 Ball valve
 4342-04 Elbow fitting
 7884-07 Elbow fitting
 8115-03 Nipple fitting
 9704-53 Black AAC tubing
 (Order quantity = hose length (ft) plus 3 feet)
 18199-02 Regulator
 18318-02 Gauge
 20182-00 AAC decal

Formula High / High Filled Resin Mixer Conversion Parts

20310-90 3/8 in mixing element
 23760-01 3/8 in front mixer housing

Small Diameter Airless/Non-Atomized Material Tip Conversion Parts

20333-00 Gasket
 22274-00 Tip spacer
 23002-00 Retaining nut
 LPA2-147-XXXX Spray tip
 23047-XX Spray tip
 23760-00 Gun front housing – For Formula Gun only
 23502-00 Gun front housing – For INDy Gun only

Repair Kits

Formula Gun
 23792-00 Gun air kit
 23793-00 Gun seal kit
 23732-00 Gun fluid valve kit

INDy Gun
 23530-00 Complete rebuild kit
 23538-00 Maintenance kit

Catalyst Pump

LPA-190-RK Complete rebuild kit
 LPA-190-SK Seal kit

11:1 & 20:1 Air Motor (5 in)

20101-00 Complete service kit
 20107-00 Pilot valve kit
 20106-00 Main valve kit
 20150-00 Gasket kit
 20104-00 Stroke signal repair kit
 20103-00 Rod seal kit
 20102-00 Piston rod seal kit

17:1 Air Motor (6 in)

21380-01 Complete service kit
 20104-00 Stroke signal repair kit
 21381-00 Bushing rod
 21382-01 Air unit
 22343-00 Valve repair kit
 22344-00 Pilot valve kit

Fluid Section

21570-00 Repair kit, 11:1 fluid section
 21799-00 Repair kit, 17:1 fluid section
 21277-00 Repair kit, 20:1 fluid section