

## 3:1 Ratio President<sup>®</sup> Pump

307674P  
ENG

Used for transfer, supply, and recirculation of compatible fluids. For professional use only.

360 psi (2.5 MPa, 25 bar) Maximum Fluid Working Pressure  
120 psi (0.8 MPa, 8.3 bar) Maximum Air Input Pressure

### Part No. 218747, Series C

Stainless Steel, Stubby Size, UHMWPE and Leather Packed

### Part No. 237142, Series A

Carbon Steel, Stubby Size, Leather Packed with PTFE Backup

### Part No. 237143, Series A

Carbon Steel, Stubby Size, Leather and PTFE Packed

### Part No. 237146, Series A

Stainless Steel, Stubby Size, PTFE Packed

### Part No. 218795, Series C

Stainless Steel, 55 Gallon (200 Liter) Drum Size,  
UHMWPE and Leather Packed

### Part No. 237144, Series A

Carbon Steel, 55 Gallon (200 Liter) Drum Size,  
Leather Packed with PTFE Backup

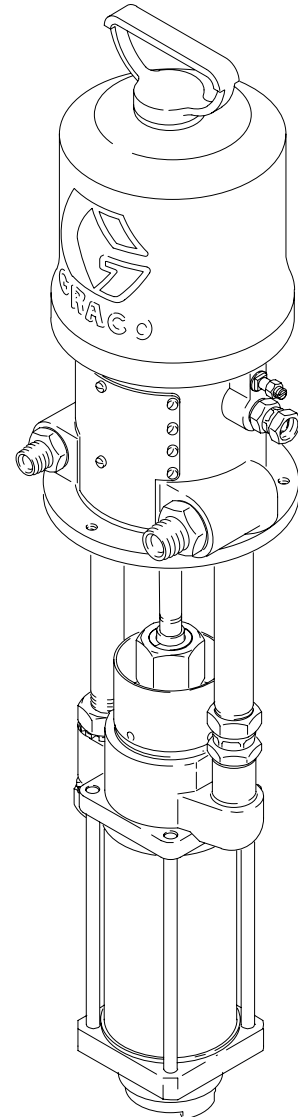

### Part No. 237145, Series A

Stainless Steel, 55 Gallon (200 Liter) Drum Size,  
PTFE Packed



Model 218747 Shown

\*This model is  0359  II 2 G T6

\*\*This model is  0359  II 1/2 G T6  
ITS03ATEX11228



### Important Safety Instructions

Read all warnings and instructions in this manual.  
Save these instructions.

# Table of Contents

Warnings .....	3
Installation .....	5
Operation .....	8
Maintenance .....	10
Troubleshooting .....	11
Service .....	12
Parts .....	14
Dimensions .....	16
Mounting Hole Layout .....	16
Technical Data .....	17
Graco Warranty .....	18
Graco Information .....	18

## Symbols

### Warning Symbol



This symbol alerts you to the possibility of serious injury or death if you do not follow the instructions.

### Caution Symbol



This symbol alerts you to the possibility of damage to or destruction of equipment if you do not follow the instructions.

# **WARNING**



## INSTRUCTIONS

### **EQUIPMENT MISUSE HAZARD**

Equipment misuse can cause the equipment to rupture or malfunction and result in serious injury.

- This equipment is for professional use only.
- Read all instruction manuals, tags, and labels before operating the equipment.
- Use the equipment only for its intended purpose. If you are not sure, call your Graco distributor.
- Do not alter or modify this equipment.
- Check equipment daily. Repair or replace worn or damaged parts immediately.
- Do not exceed the maximum working pressure of the lowest rated system component. Refer to the **Technical Data** on page 17 for the maximum working pressure of this equipment.
- Use fluids and solvents which are compatible with the equipment wetted parts. Refer to the **Technical Data** section of all equipment manuals. Read the fluid and solvent manufacturer's warnings.
- Do not use 1,1,1-trichloroethane, methylene chloride, other halogenated hydrocarbon solvents or fluids containing such solvents in aluminum equipment. Such use could result in a serious chemical reaction, with the possibility of explosion.
- Do not use hoses to pull equipment.
- Route hoses away from traffic areas, sharp edges, moving parts, and hot surfaces. Do not expose Graco hoses to temperatures above 82°C (180°F) or below -40°C (-40°F).
- Wear hearing protection when operating this equipment.
- Do not lift pressurized equipment.
- Comply with all applicable local, state, and national fire, electrical, and safety regulations.

# **WARNING**



## **FIRE AND EXPLOSION HAZARD**

Improper grounding, poor ventilation, open flames or sparks can cause a hazardous condition and result in a fire or explosion and serious injury.

- Ground the equipment and the object being sprayed. Refer to **Grounding** on page 5.
- If there is any static sparking or you feel an electric shock while using this equipment, **stop spraying immediately**. Do not use the equipment until you identify and correct the problem.
- Provide fresh air ventilation to avoid the buildup of flammable fumes from solvents or the fluid being sprayed.
- Eliminate all ignition sources such as pilot lights, cigarettes and plastic drop cloths (static arc hazard). Do not plug or unplug power cords or turn lights on or off in the spray area.
- Keep the spray area free of debris, including solvent, rags, and gasoline.
- Electrically disconnect all equipment in the spray area.
- Do not operate a gasoline engine in the spray area.



## **TOXIC FLUID HAZARD**

Hazardous fluid or toxic fumes can cause serious injury or death if splashed in the eyes or on the skin, inhaled, or swallowed.

- Know the specific hazards of the fluid you are using.
- Store hazardous fluid in an approved container. Dispose of hazardous fluid according to all local, state and national guidelines.
- Always wear protective eyewear, gloves, clothing and respirator as recommended by the fluid and solvent manufacturer.



## **MOVING PARTS HAZARD**

Moving parts, such as the air motor piston, can pinch or amputate your fingers.

- Keep clear of all moving parts when starting or operating the pump.
- Before servicing the equipment, follow the **Pressure Relief Procedure** on page 8 to prevent the equipment from starting unexpectedly.

# Installation

## General Information

**NOTE:** Reference numbers and letters in parentheses in the text refer to the callouts in the figures and the parts drawing.



**NOTE:** Always use Genuine Graco Parts and Accessories, available from your Graco distributor. If you supply your own accessories, be sure they are adequately sized and pressure rated for your system.

Fig. 2 is only a guide for selecting and installing system components and accessories. Contact your Graco distributor for assistance in designing a system to suit your particular needs.

## Prepare the Operator

All persons who operate the equipment must be trained in the safe, efficient operation of all system components as well as the proper handling of all fluids. All operators must thoroughly read all instruction manuals, tags, and labels before operating the equipment.

## Grounding

<b>⚠ WARNING</b>	
	<b>FIRE AND EXPLOSION HAZARD</b>
	Before operating the pump, ground the system as explained below. Also read the section <b>FIRE AND EXPLOSION HAZARD</b> on page 4.
	

1. *Pump:* order Part No. 237569 Ground Wire and Clamp. See Fig. 1. Loosen the grounding lug locknut (W) and washer (X). Insert one end of the ground wire (Y) into the slot in lug (Z) and tighten the locknut securely. Connect the other end of the wire to a true earth ground.

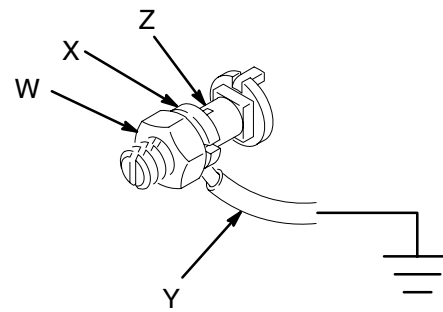

0864

**Fig. 1**

2. *Air and fluid hoses:* use only electrically conductive hoses.
3. *Air compressor:* follow manufacturer's recommendations.
4. *Spray gun:* ground through connection to a properly grounded fluid hose and pump.
5. *Fluid supply container:* follow your local code.
6. *Object being sprayed:* follow your local code.
7. *Solvent pails used when flushing:* follow your local code. Use only metal pails, which are conductive, placed on a grounded surface. Do not place the pail on a nonconductive surface, such as paper or cardboard, which interrupts the grounding continuity.
8. *To maintain grounding continuity when flushing or relieving pressure,* hold a metal part of the spray gun firmly to the side of a grounded *metal* pail, then trigger the gun.

## Mounting the Pump

Mount the pump to suit the type of installation planned. The pump dimensions and mounting hole layout are shown on page 16.

If the pump is immersed, be sure the pump intake is 1/2 in. (13 mm) off the bottom of the fluid container.

If the pump is mounted on the wall or on a stand, connect a suction line to the pump's 1-1/2" npt(f) fluid inlet and place the other end of the line in the fluid container.

# Installation

**KEY**

- |  |                                   |  |   |
|--|-----------------------------------|--|---|
| <b>A</b> Bleed-Type Master Air Valve<br>(required, for pump) | <b>F</b> Fluid Shutoff Valves     | <b>M</b> Air Supply Line                                   | <b>S</b> Main Fluid Return Line   |
| <b>B</b> Air Filter/Regulator                                | <b>G</b> Fluid Filter             | <b>N</b> Bleed-Type Master Air Valves<br>(for accessories) | <b>T</b> Secondary Fluid Return Line  |
| <b>C</b> Air Line Lubricator                                 | <b>H</b> Fluid Pressure Regulator | <b>P</b> Main Fluid Supply Line                            | <b>Y</b> Ground Wire (required;<br>see page 5 for installation<br>instructions) |
| <b>D</b> Fluid Drain Valve (required)                        | <b>J</b> Air Spray Gun            | <b>R</b> Pump Runaway Valve                                |   |
| <b>E</b> Surge Tank  | <b>L</b> Pump                     |  |   |

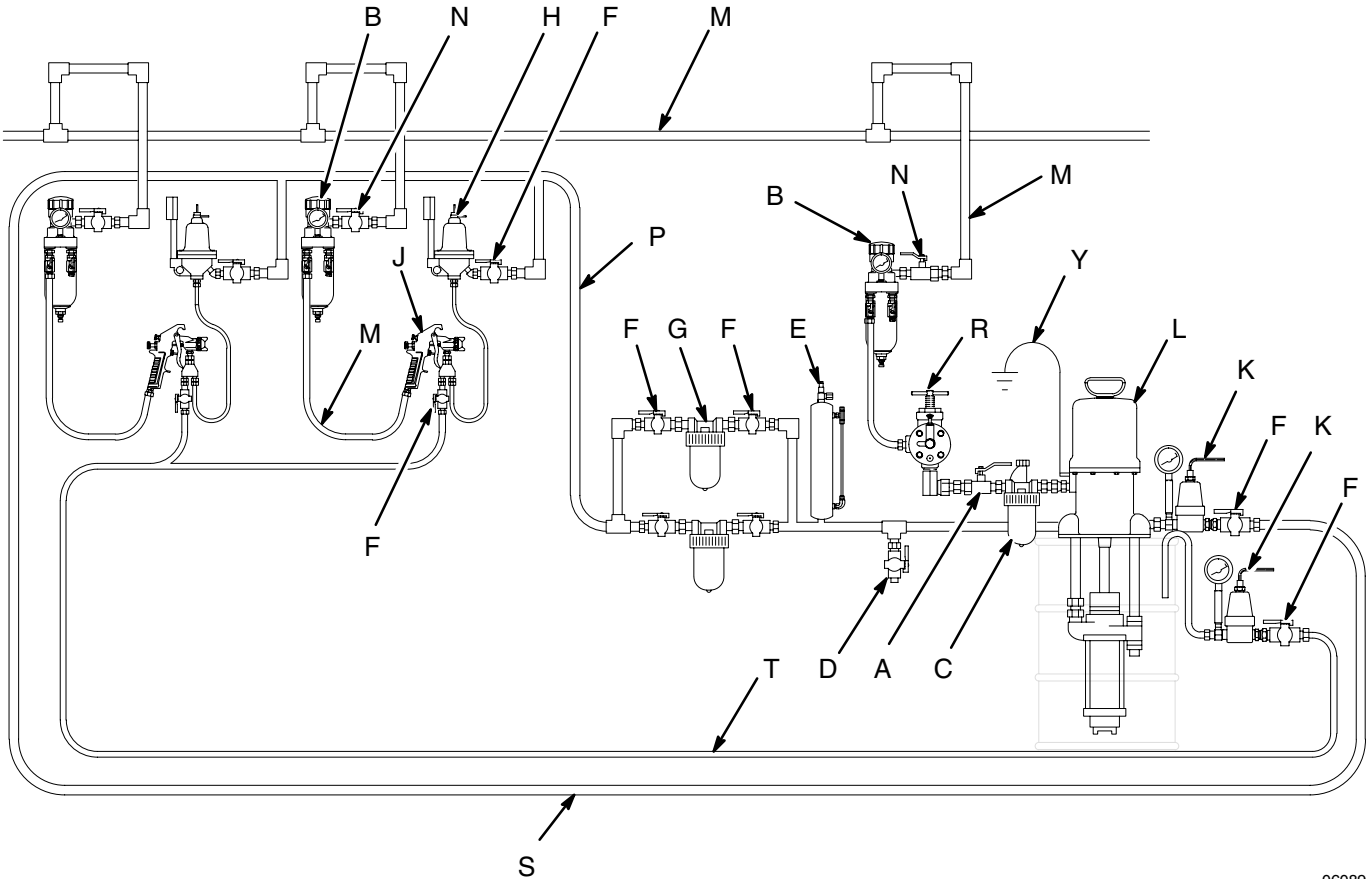

**Fig. 2**

06089

# Installation

## Available Accessories (must be purchased separately)

### Air Line Accessories

#### **WARNING**

A bleed-type master air valve (A) is required in your system to help reduce the risk of serious injury, including splashing of fluid in the eyes or on the skin, and injury from moving parts if you are adjusting or repairing the pump.

The bleed-type master air valve relieves air trapped between this valve and the pump after the air is shut off. Trapped air can cause the pump to cycle unexpectedly. Locate the valve close to the pump.

- **The bleed-type master air valve (A)** is required in your system to relieve air trapped between it and the air motor when the valve is closed (see the **WARNING** above). Be sure the bleed valve is easily accessible from the pump, and is located **downstream** from the air filter/regulator (B). Order Part No. 113269 Bleed Valve.
- **The air filter/regulator (B)** controls pump speed and outlet pressure by adjusting the air pressure to the pump and the air spray gun. It also removes harmful dirt and moisture from the compressed air supply. Locate the pump air filter/regulator **upstream** from the pump's bleed-type master air valve (A). Also, supply an air filter/regulator at each spray booth.
- **A pump runaway valve (R)** automatically shuts off the pump if it starts running too fast. A pump which runs too fast can be seriously damaged.
- **An air line lubricator (C)** provides automatic air motor lubrication. Install downstream from the pump air filter/regulator (B).
- **Install additional air bleed valves (N)** at each air line drop, to isolate accessories for servicing.

### Fluid Line Accessories

#### **WARNING**

A fluid drain valve (D) is required in your system to help reduce the risk of serious injury, including splashing of fluid in the eyes or on the skin.

The fluid drain valve assists in relieving fluid pressure in the displacement pump, hose, and gun. Triggering the gun to relieve pressure may not be sufficient.

- **The fluid drain valve (D)** is required in your system to relieve fluid pressure in the hose and gun (see the **WARNING** above).
- **Install a surge tank (E)** to reduce fluid line pulsations.
- **Install two fluid filters (G)** to remove impurities from the fluid before it reaches the spray gun (J). Install fluid shutoff valves (F) upstream and downstream from each filter; this arrangement enables you to continue spraying while cleaning a filter.
- **Install a fluid pressure regulator (H)** to provide precise fluid pressure control at each spray booth.
- **Install fluid shutoff valves (F)** where shown.

### Fluid Return Line

- **Install a main fluid return line (S)** to circulate fluid back to the pump's return port.
- **Install a secondary fluid return line (T)** to circulate fluid from the spray guns back to the fluid supply container.
- **Install a back pressure regulator (K)** on each fluid return line, after the last gun station, to provide constant system back pressure for all spray guns and proper pressure for fluid circulation.

# Operation

## Pressure Relief Procedure

### **⚠ WARNING**

#### **PRESSURIZED EQUIPMENT HAZARD**

The system pressure must be manually relieved to prevent the system from starting or spraying accidentally. To reduce the risk of an injury from accidental spray from the gun, splashing fluid, or moving parts, follow the **Pressure Relief Procedure** whenever you:

- are instructed to relieve the pressure,
- stop spraying,
- check or service any of the system equipment,
- or install or clean the spray nozzle.

1. Shut off the air supply to the pump.
2. Close the bleed-type master air valve (A, required in your system).
3. Hold a metal part of the gun firmly to the side of a grounded metal pail, and trigger the gun to relieve pressure.
4. Open the drain valve (D, required in your system), having a container ready to catch the drainage.
5. Leave the drain valve open until you are ready to spray again.

*If you suspect that the spray nozzle or hose is completely clogged, or that pressure has not been fully relieved after following the steps above, **very slowly** loosen the nozzle retaining ring or hose end coupling and relieve pressure gradually, then loosen completely. Now clear the nozzle or hose.*

## Packing Nut

### **⚠ WARNING**

To reduce the risk of serious injury whenever you are instructed to relieve pressure, always follow the **Pressure Relief Procedure** at left.

Check the tightness of the packing nut/wet-cup (U) periodically. The nut should be tight enough to prevent leakage. Torque the nut to 20–24 ft-lb (27–33 N.m); do not overtighten or you may damage the packings. **Relieve pressure** before adjusting the nut. See Fig. 3.

If the pump is not immersed, fill the packing nut/wet-cup 1/2 full with a compatible solvent. Keep the cup filled at all times to help prevent the fluid you are pumping from drying on the exposed displacement rod and damaging the throat packings.

## Flush the Pump Before First Use

The pump is tested with lightweight oil, which is left in to protect the pump parts. If the fluid you are using may be contaminated by the oil, flush it out with a compatible solvent. See **Flushing** on page 10.

### *Model 218747 Shown*

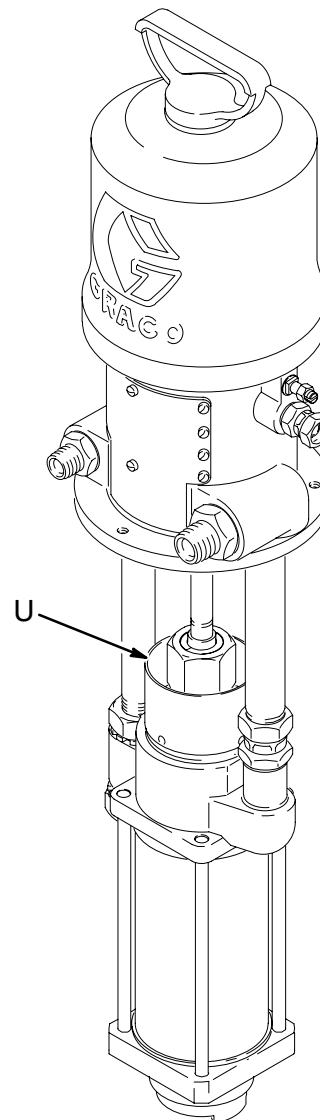

**Fig. 3**

06110

# Operation

## Prime the Pump

1. See Fig. 2. Remove the spray nozzle from the gun. See the gun instruction manual.
2. Close all bleed-type air valves (A, N).
3. Close the pump air filter/regulator (B).
4. Close the fluid drain valve (D).
5. Check that all fittings throughout the system are tightened securely.
6. Connect the air supply line to the pump air inlet.
7. Open the bleed-type air valves (A, N).
8. Hold a metal part of the gun firmly to the side of a grounded metal pail and hold the trigger open.
9. Open the air filter/regulator (B) until the pump starts. Run the pump slowly until all air is pushed out and the system is fully primed. Always use the lowest pressure necessary to get the desired results. Higher pressures cause premature tip and pump wear.
10. Release the gun trigger and lock the trigger safety.

*In a circulating system*, the pump will run continuously and slow down or speed up on demand, until the air supply is shut off.

*In a direct supply system*, with adequate air pressure supplied to the motor, the pump will start and stop as you open and close the gun.

## WARNING

To reduce the risk of serious injury whenever you are instructed to relieve pressure, always follow the **Pressure Relief Procedure** on page 8.

11. **Relieve the pressure.** Install the spray nozzle in the gun, as explained in the gun manual.

## WARNING

### COMPONENT RUPTURE HAZARD



To reduce the risk of overpressurizing your system, which could cause component rupture and serious injury, **never** exceed 120 psi (8 bar) air supply pressure to the pump.

12. Use the air filter/regulator (B) to control pump outlet pressure and pump speed. Always use the lowest pressure necessary to get the desired results. Higher pressure causes premature pump wear.

## CAUTION

Do not allow the pump to run dry. It will quickly accelerate to a high speed, causing damage. If your pump is running too fast, stop it immediately and check the fluid supply. If the container is empty and air has been pumped into the lines, refill the container and prime the pump and the lines, or flush and leave it filled with a compatible solvent. Eliminate all air from the fluid system.

# Maintenance

## Shutdown and Care of the Pump

### **WARNING**

To reduce the risk of serious injury whenever you are instructed to relieve pressure, always follow the **Pressure Relief Procedure** on page 8.

For overnight shutdown, stop the pump at the bottom of its stroke to prevent fluid from drying on the exposed displacement rod and damaging the throat packings. **Relieve the pressure.**

Always flush the pump before the fluid dries on the displacement rod. See **Flushing** below.

## Flushing

### **WARNING**



#### **FIRE AND EXPLOSION HAZARD**

Before flushing, read the section **FIRE AND EXPLOSION HAZARD** on page 4. Be sure the entire system and flushing pails are properly grounded. Refer to **Grounding** on page 5.

Flush the pump:

- Before the first use
- When changing colors or fluids
- Before fluid can dry or settle out in a dormant pump (check the pot life of catalyzed fluids)
- Before storing the pump.

Flush with a fluid that is compatible with the fluid you are pumping and with the wetted parts in your system. Check with your fluid manufacturer or supplier for recommended flushing fluids and flushing frequency.

### **CAUTION**

Never leave water or water-base fluid in the pump overnight. If you are pumping water-base fluid, flush with water first, then with a rust inhibitor such as mineral spirits. Relieve the pressure, but leave the rust inhibitor in the pump to protect the parts from corrosion.

### **WARNING**

To reduce the risk of serious injury whenever you are instructed to relieve pressure, always follow the **Pressure Relief Procedure** on page 8.

1. **Relieve the pressure.**
2. Remove the spray nozzle from the gun.
3. Hold a metal part of the gun firmly to the side of a grounded *metal* pail.
4. Start the pump. Always use the lowest possible fluid pressure when flushing.
5. Trigger the gun.
6. Flush the system until clear solvent flows from the gun.
7. **Relieve the pressure.**
8. Clean the spray nozzle separately, then reinstall it.

## Corrosion Protection for Carbon Steel Pumps

### **CAUTION**

Water, or even moist air, can cause your pump to corrode. To help prevent corrosion, **never** leave the pump filled with water or air. Follow the instructions under **Flushing**, at left.

## Fluid Piston and Intake Valve Adjustment

The fluid piston and intake valves are factory set for pumping medium viscosity fluids. See the separate displacement pump manual, 307652, for adjustment procedures to pump lighter or heavier viscosity fluids.

# Troubleshooting

## WARNING

To reduce the risk of serious injury whenever you are instructed to relieve pressure, always follow the **Pressure Relief Procedure** on page 8.

1. **Relieve the pressure.**
2. Check all possible problems and solutions before disassembling pump.

Problem	Cause	Solution
Pump fails to operate.	Restricted line or inadequate air supply.	Clear; increase air supply.
	Dirty or damaged air motor.	Service air motor (see 306982 or 307157).
	Clogged fluid hose, gun, or nozzle.	Clear.*
Pump operates but output is low on both strokes.	Restricted line or inadequate air supply.	Clear; increase air supply.
	Exhausted fluid supply.	Refill; reprime or flush.
	Clogged fluid hose, gun, or nozzle.	Clear.*
	Loose packing nut or worn throat packings.	Tighten packing nut (see page 8); replace throat packings.
	Piston and intake valves need adjustment.	Adjust; see manual 307652.
Pump operates but output is low on downstroke.	Held open or worn intake valve.	Clear; service. See manual 307652.
Pump operates but output is low on upstroke.	Held open or worn fluid piston valve or packings.	Clear; service. See manual 307652.
Erratic or accelerated operation.	Exhausted fluid supply.	Refill; reprime or flush.
	Piston and intake valves need adjustment.	Adjust; see manual 307652.
	Held open or worn intake valve.	Clear; service. See manual 307652.
	Held open or worn fluid piston valve or packings.	Clear; service. See manual 307652.

\* To determine if the fluid hose or gun is obstructed, follow the **Pressure Relief Procedure** on page 8. Disconnect the fluid hose and place a container at the pump fluid outlet to catch any fluid. Turn on the air just enough to start the pump (about 20–40 psi [1.4–2.8 bar]). If the pump starts when the air is turned on, the obstruction is in the fluid hose or gun.

# Service

## Disconnecting the Displacement Pump

**NOTE:** For displacement pump repair instructions, refer to the separate displacement pump manual 307652, supplied.

### **WARNING**

To reduce the risk of serious injury whenever you are instructed to relieve pressure, always follow the **Pressure Relief Procedure** on page 8.

1. Flush the pump if possible. Stop the pump at the bottom of its stroke. **Relieve the pressure.**
2. Disconnect all hoses and remove the pump from its mounting.
3. Unscrew the coupling nut (20) from the displacement rod (R). Remove the coupling collars (21). See Fig. 4.
4. Unscrew the lower locknut (13) and lockwasher (12) from the return mounting tube (10).
5. Unscrew the swivel union (S) from the supply mounting tube (11).

### **CAUTION**

If you are removing the mounting tubes, wrench the tubes close to the motor base to prevent thread damage in the base. Use thread sealant on the male threads when reinstalling.

## Reconnecting the Displacement Pump

1. Position the displacement pump on the mounting tubes (10, 11). Thread the upper locknut (13) onto the return mounting tube (10) a couple of turns. Tighten the swivel union (S) securely onto the supply mounting tube (11). See Fig. 4.
2. Butt the connecting rod (2) and displacement rod (R) together; if necessary, adjust the locknuts (13) on the return mounting tube (10) to align the rods.
3. Position the coupling collars (21) so they engage with the connecting rod (2) and displacement rod (R). Lower the coupling nut (20) over the coupling collars and screw it securely onto the displacement rod.
4. Tighten the locknuts (13) securely.
5. Remount the pump and connect all hoses.
6. Turn on the air to the motor and run the pump slowly. Adjust the locknuts (13) on the return mounting tube (10) as necessary until the pump operates smoothly at minimum air pressure to the motor. Tighten the locknuts securely.
7. Reconnect the ground wire if it was disconnected during repair.
8. If the pump is not immersed, fill the packing nut/wet-cup 1/2 full of compatible solvent.



# Parts

## Model 218747, Series C

3:1 Ratio President Pump, Stubby Size; UHMWPE and Leather Packed

## Model 237142, Series A

3:1 Ratio President Pump, Stubby Size; Leather Packed with PTFE Backup



## Model 237143, Series A

3:1 Ratio President Pump, Stubby Size; Leather and PTFE Packed

## Model 237146, Series A

3:1 Ratio President Pump, Stubby Size; PTFE Packed

Ref No.	Part No.	Description	Qty
1	210007	AIR MOTOR, President; used on 218747; see 307157	1
	205038	AIR MOTOR, President used on 237142, 237143, and 237146; see 306982	1
2	190116	ROD, connecting; 5.69" (144.5 mm) long	1
3	218746	PUMP, displacement; used on 218747; see 307652	1
	237140	PUMP, displacement; used on 237142; see 307652	1
	237141	PUMP, displacement; used on 237143; see 307652	1
	237199	PUMP, displacement; used on 237146; see 307652	1
4	100579	PIN, cotter	1
6	156082	O-RING; nitrile rubber	1
8	166443	NIPPLE, hex, reducing; 3/4 x 1/2 npt	1
10	180986	TUBE, return; 12.812" (325.4 mm) long	1
11	189215	TUBE, supply; 6.75" (171.5 mm) long; used on 218747, 237142, and 237143 only	1
	112919	TUBE, supply; 1" npt(f) fluid outlet; 6.75" (171.5 mm) long; used on 237146 only	1
12	118160	LOCKWASHER, ext shakeproof	2
13	171217	NUT, lock; 3/4-11	2
14	171439	NIPPLE, hex, reducing; 1" x 3/4 npt	1
15	158256	UNION; straight adapter; 1/2 npt(m) x 3/8 npsm(f)	1
20	190117	NUT, coupling	1
21	190119	COLLAR, coupling	2

 Used on Models 2218747, 237142, and 237143 only.  
 Used on Model 237146 only.

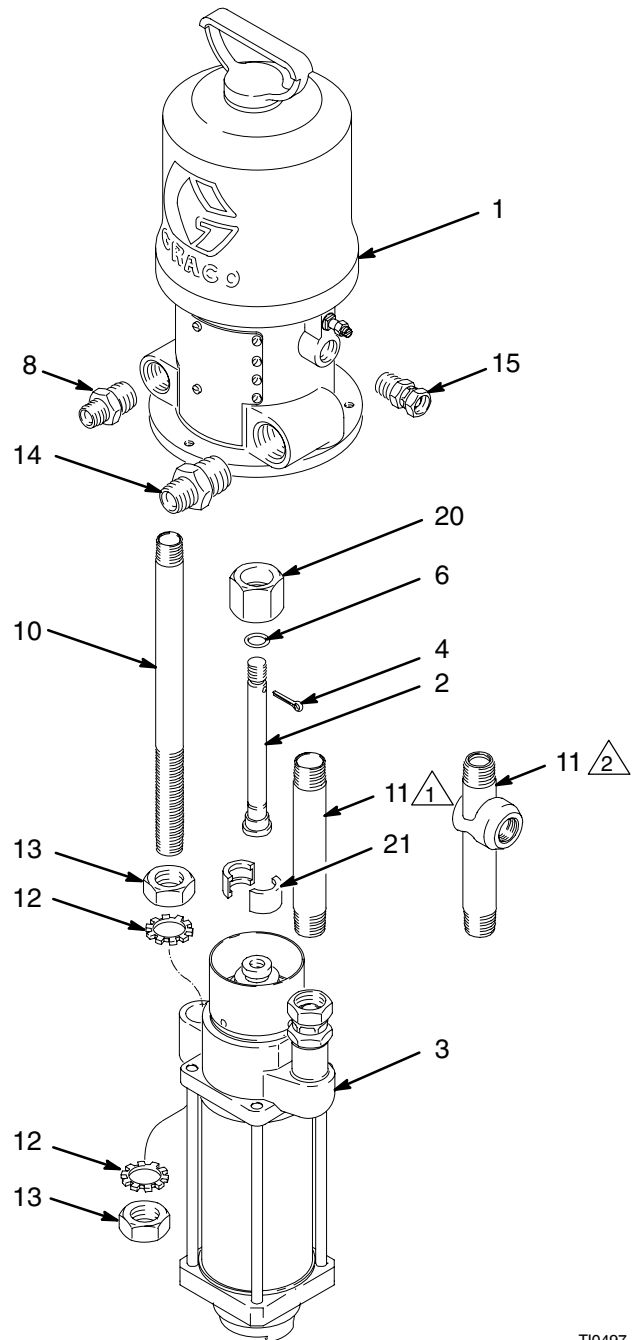

# Parts

## Model 218795, Series C

3:1 Ratio President Pump, 55 Gallon (200 Liter) Drum Size;  
 UHMWPE and Leather Packed

## Model 237144, Series A

3:1 Ratio President Pump, 55 Gallon (200 Liter) Drum Size;  
 Leather Packed with PTFE Backup

## Model 237145, Series A

3:1 Ratio President Pump,  
 55 Gallon (200 Liter) Drum Size; PTFE Packed

Ref No.	Part No.	Description	Qty
1	210007	AIR MOTOR, President; used on 218795; see 307157	1
	205038	AIR MOTOR, President; used on 237144 and 237145; see 306982	1
2	190115	ROD, connecting; 18.25" (463.6 mm) long	1
3	218746	PUMP, displacement; used on 218795; see 307652	1
	237140	PUMP, displacement; used on 237144; see 307652	1
	237199	PUMP, displacement; used on 237145; see 307652	1
4	100579	PIN, cotter	1
6	156082	O-RING; nitrile rubber	1
7	100081	BUSHING; 1/2 npt(m) x 3/8 npt(f); used on 218795 only	1
8	160032	NIPPLE; 3/4 npt	1
10	180990	TUBE, return; 25.375" (644.5 mm) long	1
11	189216	TUBE, supply; 19.312" (490.52 mm) long; used on 218795 and 237144 only	1
	112918	TUBE, supply; 1" npt(f) fluid outlet; 19.312" (490.52 mm) long; used on 237145 only	1
12	118160	LOCKWASHER, ext shakeproof	2
13	171217	NUT, lock; 3/4-11	2
15	158256	UNION; straight adapter; 1/2 npt(m) x 3/8 npsm(f); used on 237144 and 237145 only	1
20	190117	NUT, coupling	1
21	190119	COLLAR, coupling	2

- ① Used on Models 237144 and 237145 only.
- ② Used on Model 218795 only (not shown).
- ③ Used on Models 218795 and 237144 only.
- ④ Used on Model 237145 only.

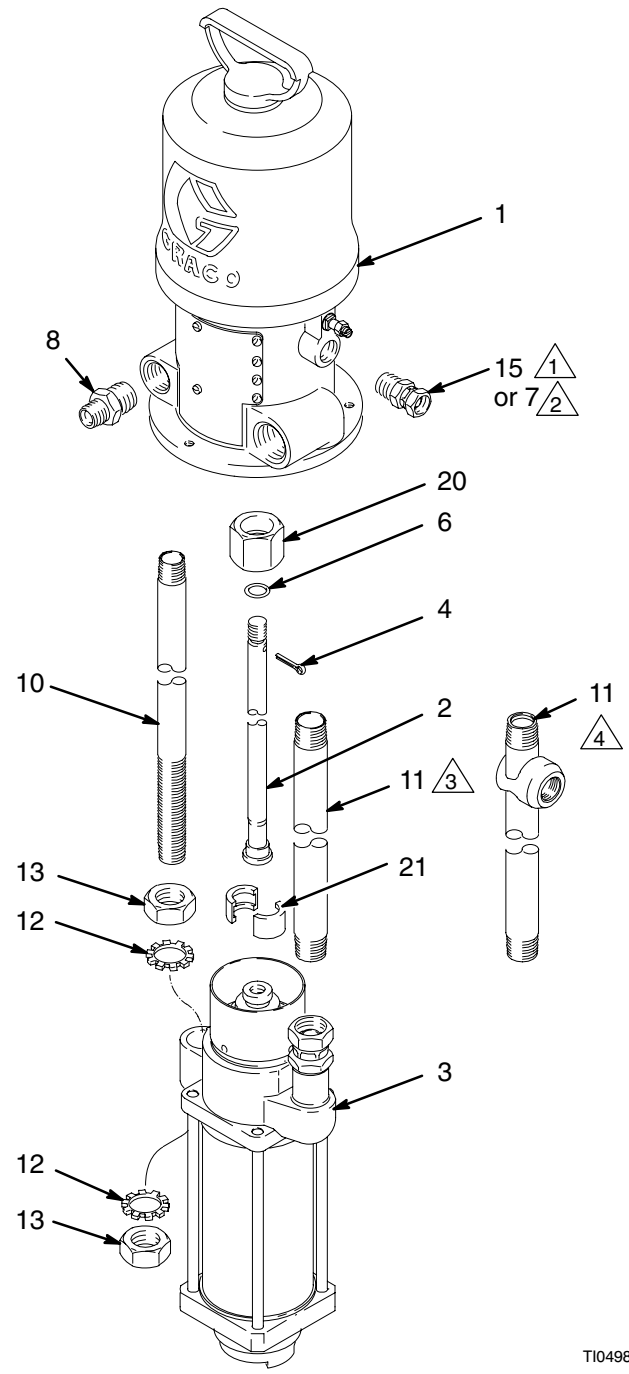

# Dimensions

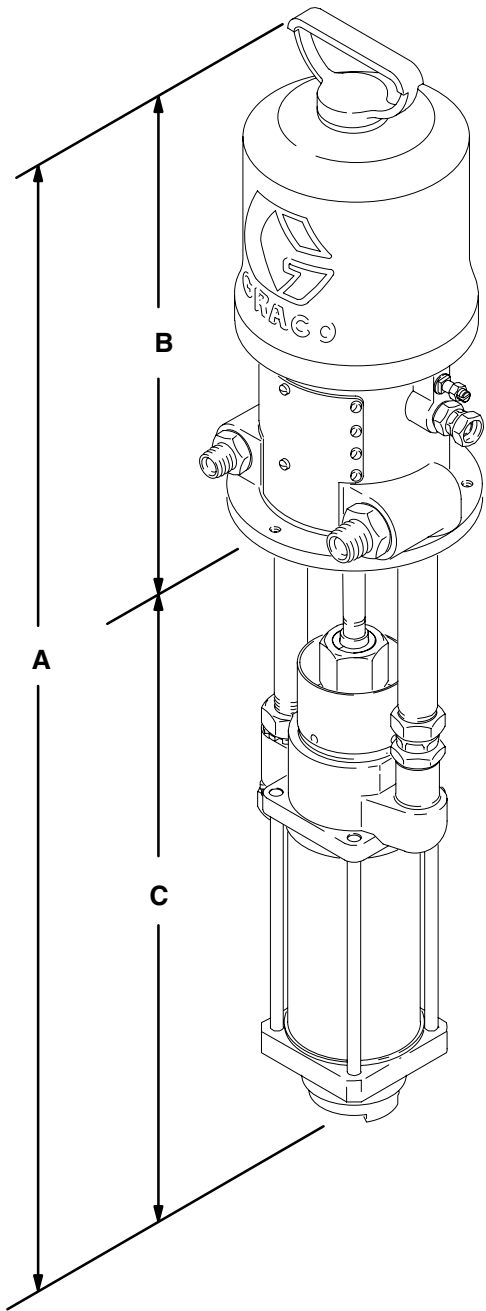

06110

# Mounting Hole Layout

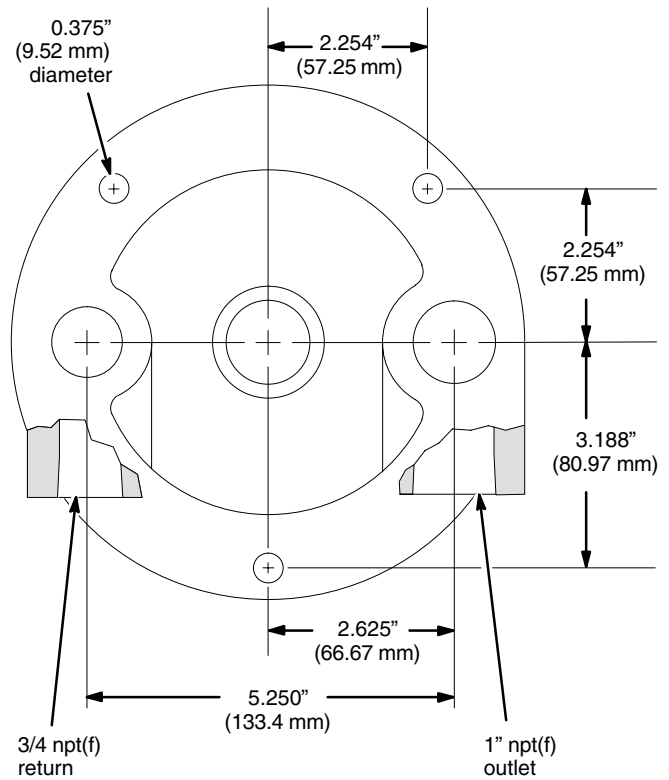

**NOTE:** Use mounting gasket 161322.

06088

Model No.	A	B	C
218795	48.88 in. (1242 mm)	16.38 in. (416 mm)	32.5 in. (826 mm)
237144, 237145	48.95 in. (1244 mm)	16.45 in. (418 mm)	32.5 in. (826 mm)
218747	36.38 in. (924 mm)	16.38 in. (416 mm)	20 in. (508 mm)
237142, 237143, 237146	36.45 in. (926 mm)	16.45 in. (418 mm)	20 in. (508 mm)

# Technical Data

Category	Data
Ratio	3:1
Maximum fluid working pressure	360 psi (2.5 MPa, 25 bar)
Maximum air input pressure	120 psi (0.8 MPa, 8.3 bar)
Pump cycles per 1 gallon (3.8 liters)	6
Fluid flow at 60 cycles per minute	10 gpm (38 liters/min)
Fluid inlet size	1-1/2 npt(f)
Fluid outlet size	1 in. npt(f)
Air inlet size	3/8 npsm(f)
Weight	47 lb (21.32 kg)
Maximum pump operating temperature	180°F (82°C)
* Sound level at 100 psi, 60 cycles per minute	94 dBa
* Sound power level at 100 psi, 60 cycles per minute	109 dBa
Wetted parts	<i>Supply and Return Tubes:</i> Stainless steel <i>Air Motor Base:</i> Aluminum <i>Displacement Pump:</i> Refer to manual 307652

\* Tested in accordance with ISO 3744.

## Performance Charts

- A 100 psi (7 bar) air pressure
- B 70 psi (4.9 bar) air pressure
- C 40 psi (2.8 bar) air pressure

**Fluid Outlet Pressure Chart**

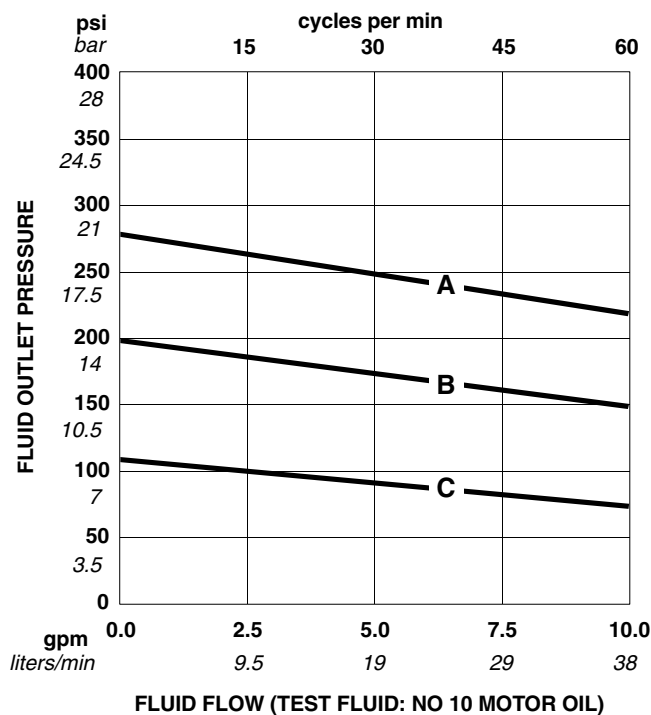

**Air Consumption Chart**

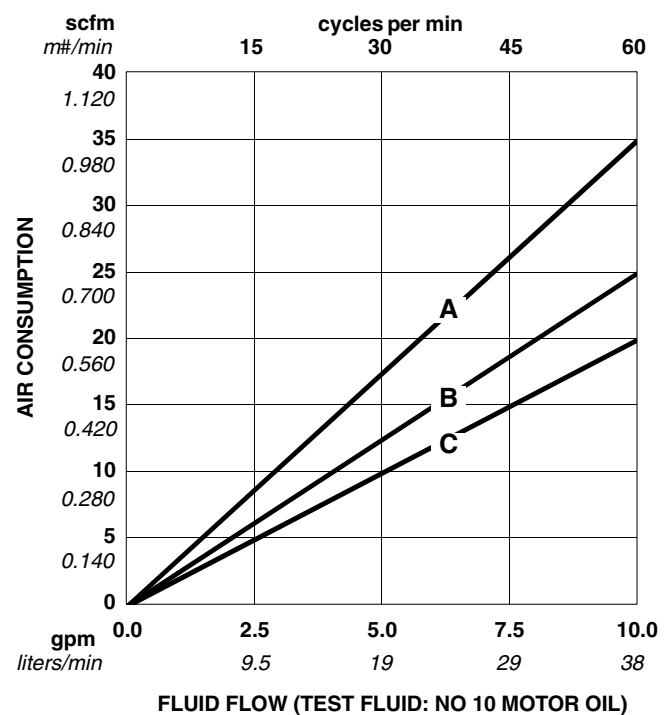

**To find Fluid Outlet Pressure** (bar/psi) at a specific fluid flow (lpm/gpm) and operating air pressure (bar/psi):

1. Locate desired flow along bottom of chart.
2. Follow vertical line up to intersection with selected fluid outlet pressure curve. Follow left to scale and read fluid outlet pressure.

**To find Pump Air Consumption** (m³/min or scfm) at a specific fluid flow (lpm/gpm) and operating air pressure (bar/psi):

1. Locate desired flow along bottom of chart.
2. Follow vertical line up to intersection with selected air consumption curve. Follow left to scale and read air consumption.