

3:1 Ratio President[®] Heated Circulation Package

308770F

Part No. 232090, Series A

With stainless steel pump, 239857 Supply Module, and 120V Viscon HP Heater Package includes mounting hardware, air controls, back pressure regulator, stainless steel fluid filter, elevator, back-geared agitator, and drum cover

*300 psi (2.1 MPa, 21 bar)
Maximum Working Pressure*

*100 psi (0.7 MPa, 7 bar)
Maximum Air Inlet Pressure*



Read warnings and instructions.
See page 2 for Table of Contents.

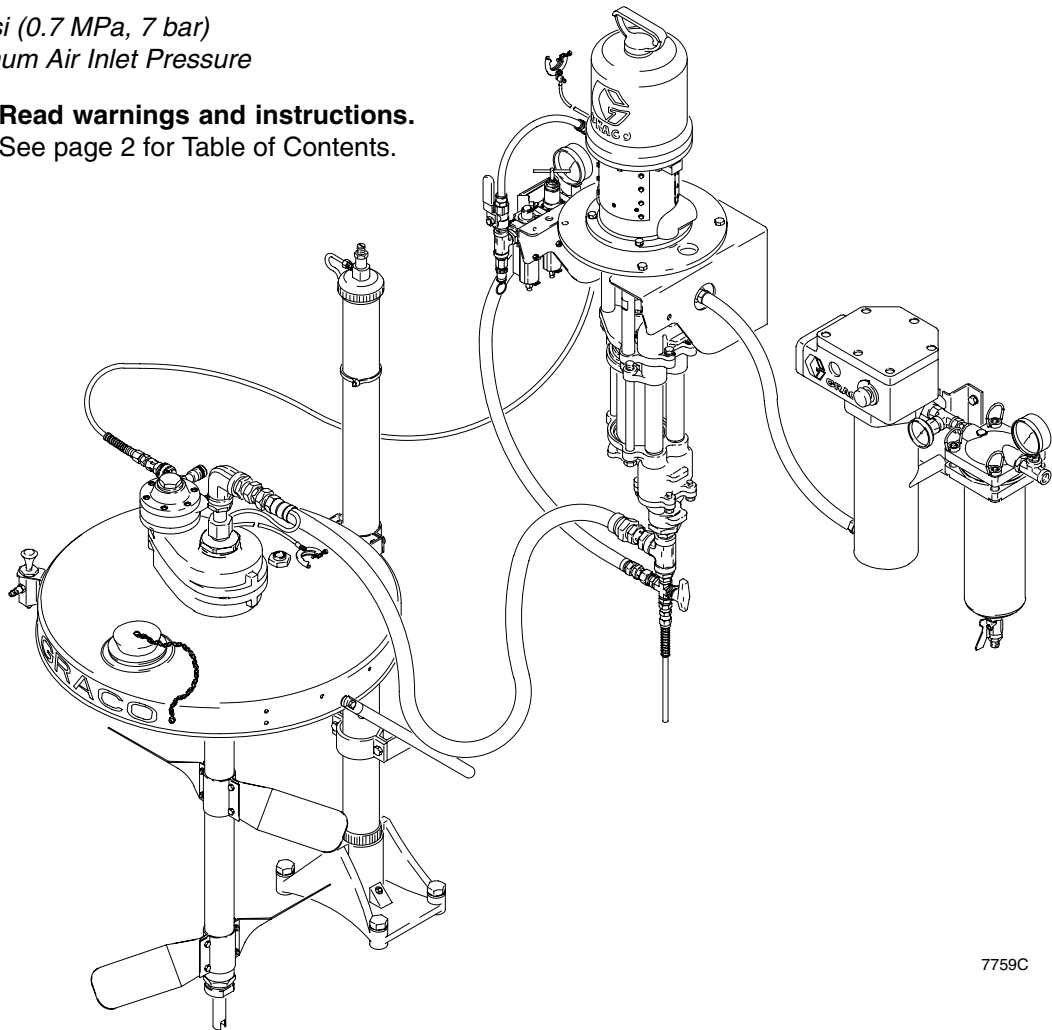

7759C

PROVEN QUALITY. LEADING TECHNOLOGY.

Table of Contents

Warnings	2
Installation	5
Operation	14
Maintenance	18
Parts	20
Technical Data	25
Dimensions	26
Mounting Hole Layouts	27
Graco Standard Warranty	28
Graco Information	28

Symbols

Warning Symbol



This symbol alerts you to the possibility of serious injury or death if you do not follow the instructions.

Caution Symbol



This symbol alerts you to the possibility of damage to or destruction of equipment if you do not follow the instructions.

! WARNING



INSTRUCTIONS

EQUIPMENT MISUSE HAZARD

Equipment misuse can cause the equipment to rupture or malfunction and result in serious injury.

- This equipment is for professional use only.
- Read all instruction manuals, tags, and labels before operating the equipment.
- Use the equipment only for its intended purpose. If you are uncertain about usage, call your Graco distributor.
- Do not alter or modify this equipment. Use only genuine Graco parts and accessories.
- Check equipment daily. Repair or replace worn or damaged parts immediately.
- Do not exceed the maximum working pressure stated on the equipment or in the **Technical Data** section for your equipment. Do not exceed the maximum working pressure of the lowest rated component in your system.
- Use fluids and solvents which are compatible with the equipment wetted parts. Refer to the **Technical Data** section of all equipment manuals. Read the fluid and solvent manufacturer's warnings.
- Route hoses away from traffic areas, sharp edges, moving parts, and hot surfaces. Do not expose Graco hoses to temperatures above 180°F (82°C) or below -40°F (-40°C).
- Do not touch the heater during operation; it is very hot.
- Wear hearing protection when operating this equipment.
- Do not lift pressurized equipment.
- Comply with all applicable local, state, and national fire, electrical, and safety regulations.

WARNING



PRESSURIZED EQUIPMENT HAZARD

Spray from the gun, hose leaks, or ruptured components can splash fluid in the eyes or on the skin and cause serious injury.

- Do not point the gun at anyone or at any part of the body.
- Do not stop or deflect leaks with your hand, body, glove, or rag.
- Follow the **Pressure Relief Procedure** on page 14 whenever you: are instructed to relieve pressure; stop spraying; clean, check, or service the equipment; and install or clean the spray tip.
- Tighten all fluid connections before operating the equipment.
- Check the hoses, tubes, and couplings daily. Replace worn, damaged, or loose parts immediately. Permanently coupled hoses cannot be repaired; replace the entire hose.



MOVING PARTS HAZARD

Moving parts, such as the air motor piston, elevator, and agitator blades, can pinch or amputate your fingers.

- Keep clear of all moving parts when starting or operating the pump.
- Keep your hands away from the elevator, pump support, drum cover, and the lip of the drum while the elevator is operating or is charged with air.
- Always shut off the agitator and disconnect the air line before you remove the agitator from the drum or check or repair any part of the agitator.
- Before servicing the equipment, follow the **Pressure Relief Procedure** on page 14 to prevent the equipment from starting unexpectedly.

WARNING



FIRE, EXPLOSION, AND ELECTRIC SHOCK HAZARD

Improper grounding, poor ventilation, open flames, or sparks can cause a hazardous condition and result in a fire or explosion and serious injury.



- The electric heater must be installed, operated, and serviced only by trained, qualified personnel who fully understand the requirements stated in the heater instruction manual (supplied).
- Ground the equipment and the object being sprayed. Refer to **Grounding** on page 13.
- If there is any static sparking or you feel an electric shock while using this equipment, **stop spraying immediately**. Do not use the equipment until you identify and correct the problem.
- Provide fresh air ventilation to avoid the buildup of flammable fumes from solvents or the fluid being sprayed.
- Keep the spray area free of debris, including solvent, rags, and gasoline.
- Electrically disconnect all equipment in the spray area.
- Extinguish all open flames or pilot lights in the spray area.
- Do not smoke in the spray area.
- Do not turn on or off any light switch in the spray area while operating or if fumes are present.
- Do not operate a gasoline engine in the spray area.



TOXIC FLUID HAZARD

Hazardous fluid or toxic fumes can cause serious injury or death if splashed in the eyes or on the skin, inhaled, or swallowed.

- Know the specific hazards of the fluid you are using.
- Store hazardous fluid in an approved container. Dispose of hazardous fluid according to all local, state, and national guidelines.
- Always wear protective eyewear, gloves, clothing, and respirator as recommended by the fluid and solvent manufacturer.

Installation

General Information

NOTE: Reference numbers and letters in parentheses in the text refer to the callouts in the figures and the parts drawing.

NOTE: Always use Genuine Graco Parts and Accessories, available from your Graco distributor. Refer to Product Data Sheet 305896. If you supply your own accessories, be sure they are adequately sized and pressure-rated for your system.

Prepare the Operator

All persons who operate the equipment must be trained in the safe, efficient operation of all system components as well as the proper handling of all fluids. All operators must thoroughly read all instruction manuals, tags, and labels before operating the equipment.

The following manuals are included with this equipment:

- 308793, 3:1 President Pump
- 306982, President Air Motor
- 308918, Fluid Filter
- 307068, Fluid Ball Valves
- 308401, Back Pressure Regulator
- 308769, Supply Module
- 306287, Elevator
- 308466, Drum Cover
- 308609, Back-Geared Agitator
- 309524, Viscon HP Heater

Prepare the Site

Select a site with at least 9 ft (2.8 m) overhead clearance for the elevator when fully raised.

Ensure that the wall is strong enough to support the weight of the pump and accessories, heater, fluid, hoses, and stress caused during pump operation.

Ensure that you have an adequate compressed air supply. Refer to the performance chart on page 25 to find the air consumption.

Refer to Fig. 1 on page 7. Bring a compressed air supply line (A) from the air compressor to the pump location. Be sure all air hoses are properly sized and pressure-rated for your system. Use only electrically conductive hoses. The air hose should have a 3/8 npt(m) thread.

Install a bleed-type shutoff valve (B) in the air line to isolate the air line components for servicing. Install a moisture trap and drain valve (C) to help remove moisture and contaminants from the compressed air supply.

Keep the site clear of any obstacles or debris that could interfere with the operator's movement.

Have a grounded, metal pail available for use when flushing the system.

Installation

Supplied Components

Refer to Fig. 1.

WARNING

A red-handled bleed-type master air valve (11h) and a fluid drain valve (208) are supplied. These components help reduce the risk of serious injury, including splashing of fluid in the eyes or on the skin, and injury from moving parts if you are adjusting or repairing the pump.

The bleed-type master air valve relieves air trapped between this valve and the pump after the air is shut off. Trapped air can cause the pump to cycle unexpectedly. Locate the valve close to the pump.

The fluid drain valve assists in relieving fluid pressure in the displacement pump, hose, and gun. Triggering the gun to relieve pressure may not be sufficient.

- **The red-handled bleed-type master air valve (11h)** is required in your system to relieve air trapped between it and the air motor when the valve is closed (see the **WARNING** above). Be sure the bleed valve is easily accessible from the pump, and is located **downstream** from the pump air filter/regulator (11a).
- **The pump air filter/regulator (11a)** controls pump speed and outlet pressure by adjusting the air pressure to the pump. It includes an air filter with a 40 micron polypropylene element, to remove harmful dirt and moisture from the compressed air supply. Locate close to the pump, but **upstream** from the bleed-type master air valve (11h).
- **The air line lubricator (11b)** provides automatic lubrication of the air motor.
- **The air relief valve (11j)** opens automatically to prevent overpressurization of the pump.
- Fluid is supplied to the pump through the **suction hose (16)** and **tube (109)**. The suction tube (109) is installed in the shaft of the agitator (102). See Fig. 1.
- **The fluid filter (206)** includes a 60 mesh (250 micron) stainless steel element to filter particles from the fluid as it leaves the pump.
- **The fluid drain valve (208)**, is mounted in the bottom of the fluid filter bowl, and is required in your system to relieve fluid pressure in the hose and gun (see the **WARNING** at left).
- **The back pressure regulator (12)** controls back pressure to the gun and maintains proper circulation pressure.
- **The back-gearred agitator (102)** keeps the fluid in suspension and also includes a suction tube (109) to draw fluid from a 55 gallon drum.
- **The air-operated elevator (150)** allows you to raise the drum cover and agitator from an empty drum, replace the drum, and lower the agitator into the new drum.

Installation

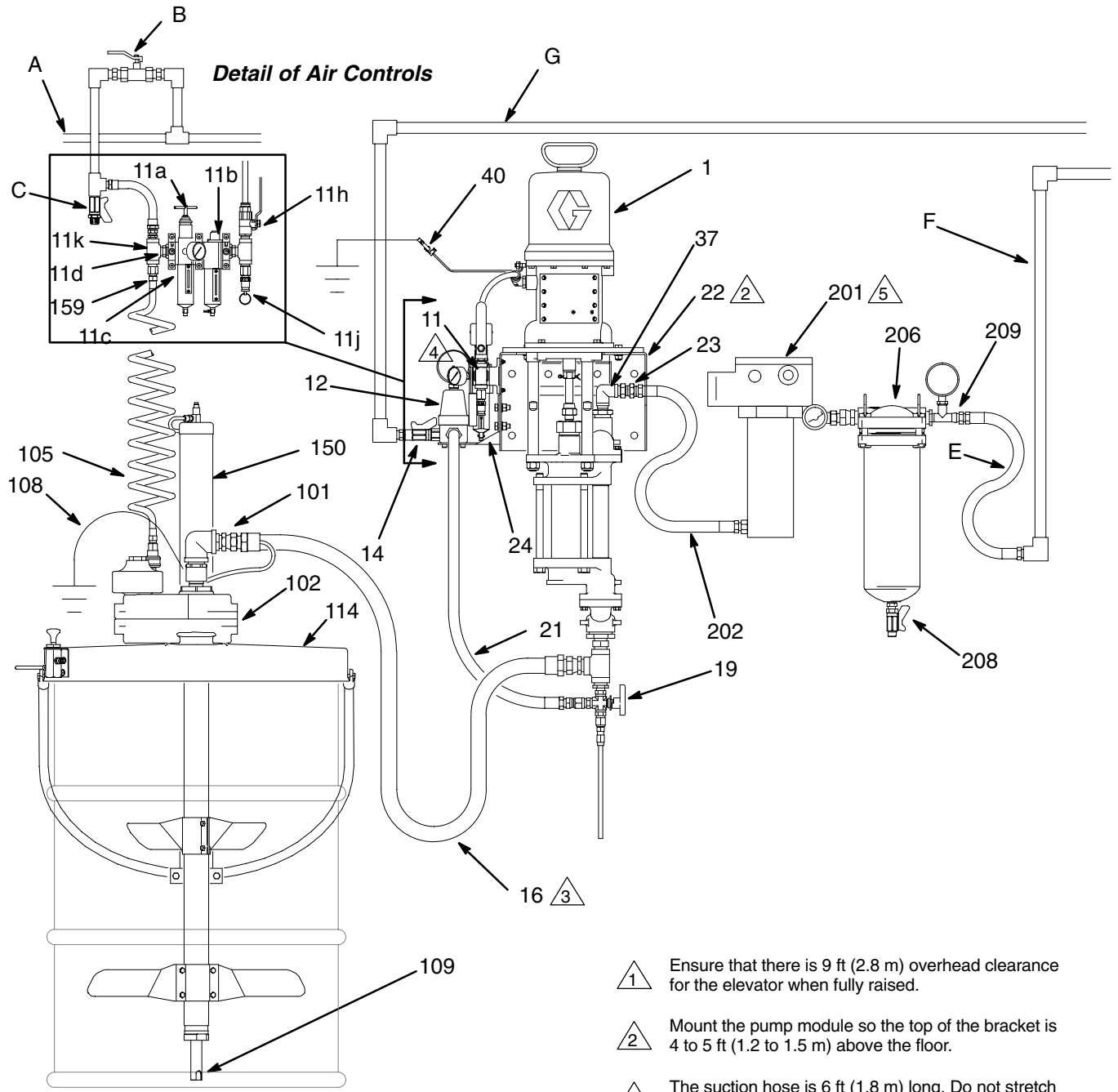

- 1 Ensure that there is 9 ft (2.8 m) overhead clearance for the elevator when fully raised.
- 2 Mount the pump module so the top of the bracket is 4 to 5 ft (1.2 to 1.5 m) above the floor.
- 3 The suction hose is 6 ft (1.8 m) long. Do not stretch the hose tight; let it hang as shown, to assist fluid flow into the pump.
- 4 See **Detail of Air Controls** in upper left corner.
- 5 The center of the two outer left holes of the heater bracket must be no more than 9 in. (228 mm) from the right edge of the pump bracket (22). See page 27.

Fig. 1

7760C

Installation

Installing the Pump Module

The pump module consists of the pump mounted on the pump bracket, the air controls, back pressure regulator, hoses, and plumbing.

NOTE: Refer to Fig. 1 on page 7, and to the Dimension drawing on page 26 and the Mounting Hole Layouts on page 27.

1. Ensure that the wall is strong enough to support the weight of the pump and accessories, heater, fluid, hoses, and stress caused during pump operation.
2. Mount the pump near a site with at least 9 ft (2.8 m) overhead clearance for the elevator when fully raised.
3. Position the bracket mounting plate (37) on the wall so the edge with the hook is facing up. Mount the plate so the top edge is 4 to 5 ft (1.2 to 1.5 m) above the floor. Check that the plate is level. Mark two holes on the wall, using the plate as a template. Drill two holes and attach the plate with 1/2 in. bolts and washers.

4. Using two people, hang the pump module on the bracket mounting plate (37). Have one person hold the module in place while the other checks that the pump bracket (22) is level. Mark four holes on the wall, using the pump bracket as a template. Remove the pump module.
5. Drill four holes in the wall.

WARNING

The pump bracket (22) must be bolted to the wall with four bolts. Do not simply hang the pump bracket on the bracket mounting plate (37).

6. Lift the pump module back into position, hang it on the bracket mounting plate (37), and bolt the pump bracket (22) to the wall. Use 1/2 in. bolts and washers to mount the pump module to the wall. Use bolts that are long enough to keep the pump bracket (22) from vibrating during operation.

Installation

Installing the 239857 Supply Module

NOTE: Refer to Fig. 1 on page 7, and to the Dimension drawing on page 26 and the Mounting Hole Layouts on page 27.

1. Ensure that there is at least 9 ft (2.8 m) overhead clearance for the elevator (150) when fully raised.

WARNING

To reduce the risk of serious injury whenever you are instructed to relieve pressure, always follow the **Pressure Relief Procedure** on page 14.

2. Locate the elevator (150) so the pump module's suction hose (16) will reach the swivel (101) at the top of the agitator (102). The suction hose is 6 ft (1.8 m) long. Do not stretch the hose tight; let it hang as shown in Fig. 1, to assist fluid flow into the pump.
3. See page 27. Using the elevator base as a template, mark the floor. Drill four holes in the floor for 1/2 in. bolts. Make sure the bolts are long enough to prevent the elevator from tipping.
4. Connect the suction hose (16) to the swivel outlet (101) of the agitator (102). Connect the suction hose ground wire to the ground lug on the agitator as shown on page 13.
5. Loosen the captive screw and open the quick connector (11c) on the air filter/regulator/lubricator assembly (11). Refer to **Using the Quick Connectors**, at right.
6. Slide the pipe adapter (11d) out of the quick connector. Remove and discard the pipe plug from the bottom port of the tee (11k).
7. Bring the coiled hose (105) up through the large hole in the back pressure regulator's bracket (24).
8. Screw the adapter (159) at the end of the coiled hose (105) into the tee (11k).
9. Slide the pipe adapter (11d) into the quick connector (11c), close, and tighten the captive screw.

Using the Quick Connectors

To open a quick connector (11c), loosen the captive screw (S) and open the connector. Slide the desired component into the connector, close, and tighten the screw. See Fig. 2.

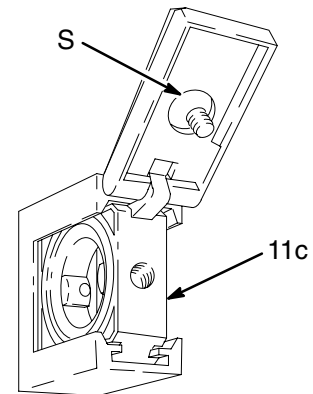

06278

Fig. 2

Connect the Fluid Lines

Connect a 1 to 3 ft (0.3–0.9 m) hose (E) to the tee (209) at the outlet of the fluid filter (206), to isolate the pump module from the main fluid line. Connect the other end of the hose to the main fluid line (F).

Connect the fluid return line (G) to the ball valve (14) at the inlet of the back pressure regulator (12). The return hose (21) connects the back pressure regulator to the 3-way recirculation valve (19). As an option, the return hose may be connected to the return line fitting (155) on the drum cover (114).

Connect the Air Line

Connect the main air supply line (A) to the tee (11k) of the air filter/regulator/lubricator assembly (11).

Installation

Fluid Heater

The fluid heater (201) heats the fluid as it passes through, to maintain the correct spraying viscosity.

Read and understand all instructions in the supplied heater manual (309524) before operating the heater.

WARNING



FIRE, EXPLOSION, AND ELECTRIC SHOCK HAZARD

The Viscon HP Heater must be installed by a qualified electrician in compliance with all state and local codes and regulations, to reduce the risk of electric shock or other serious injury during installation or operation.



When installing in a flammable atmosphere (hazardous location) refer to

Article 500 of the US National Electric Code or other applicable agency standards to plan the work.

Refer to the **Technical Data** section and to the supplied Viscon HP Heater manual (309524) for information on heater power supply requirements.

Do not plug in or unplug a power cord in any area containing flammable fluids or fumes, to avoid fire or explosion resulting in serious injury.

Do not put all flammable materials and debris on or near the heater. Keep the work area clean.

WARNING

COMPONENT RUPTURE HAZARD



Heat causes fluid to expand. If the heated fluid is trapped with nowhere to expand, it can cause component rupture.

Be sure to keep the heated fluid circulating (turn the 3-way recirculation valve to the circulation position). **Do not** install a fluid shutoff device between the heater and the gun.

Conversion Modules

Heater Modules 239851 (240V), 239852 (240V), and 241883 (200V)

Heater Modules are available to convert the heated circulation package to a different voltage. Each module includes a heater configured to the desired voltage, and mounting hardware. Instructions are included.

Surge Tank Module 239858

Part No. 239858 Surge Tank Module is available as an accessory. The module includes a surge tank, stand, and connecting hardware. Instructions are included.

Installation

Installing the Heater Module

NOTE: Refer to Fig. 3, and to the Dimension drawing on page 26 and the Mounting Hole Layouts on page 27.

1. Position the heater bracket (205) to the right of the pump bracket (22), at the same height. The two slots must face up. The center of the two outer left holes must be no more than 9 in. (228 mm) from the right edge of the pump bracket. See page 27.
2. Check that the heater bracket (205) is level. Using the bracket as a template, mark the four outer holes on the wall. The four outer holes are used to mount the bracket to the wall, and the two inner slots and two inner holes are to mount the heater (201) to the bracket.
3. Drill four holes in the wall.
4. Bolt the bracket (205) to the wall with 1/2 in. bolts and washers. Use bolts that are long enough to keep the bracket from vibrating during operation.
5. Install two screws (D, included with the heater) into the top two heater mounting posts until they are about 1/8 in. (3 mm) from fully installed.
6. Using two people, lift the heater (201) onto the bracket (205) so the two screw heads (D) slide into the slots. Have one person hold the heater in place while the other installs the remaining two screws (supplied with the heater) through the bracket and into the bottom mounting posts. Tighten all four screws.
7. Connect the free end of the heater supply hose (202) to the swivel (23) at the pump fluid outlet. Tighten securely.

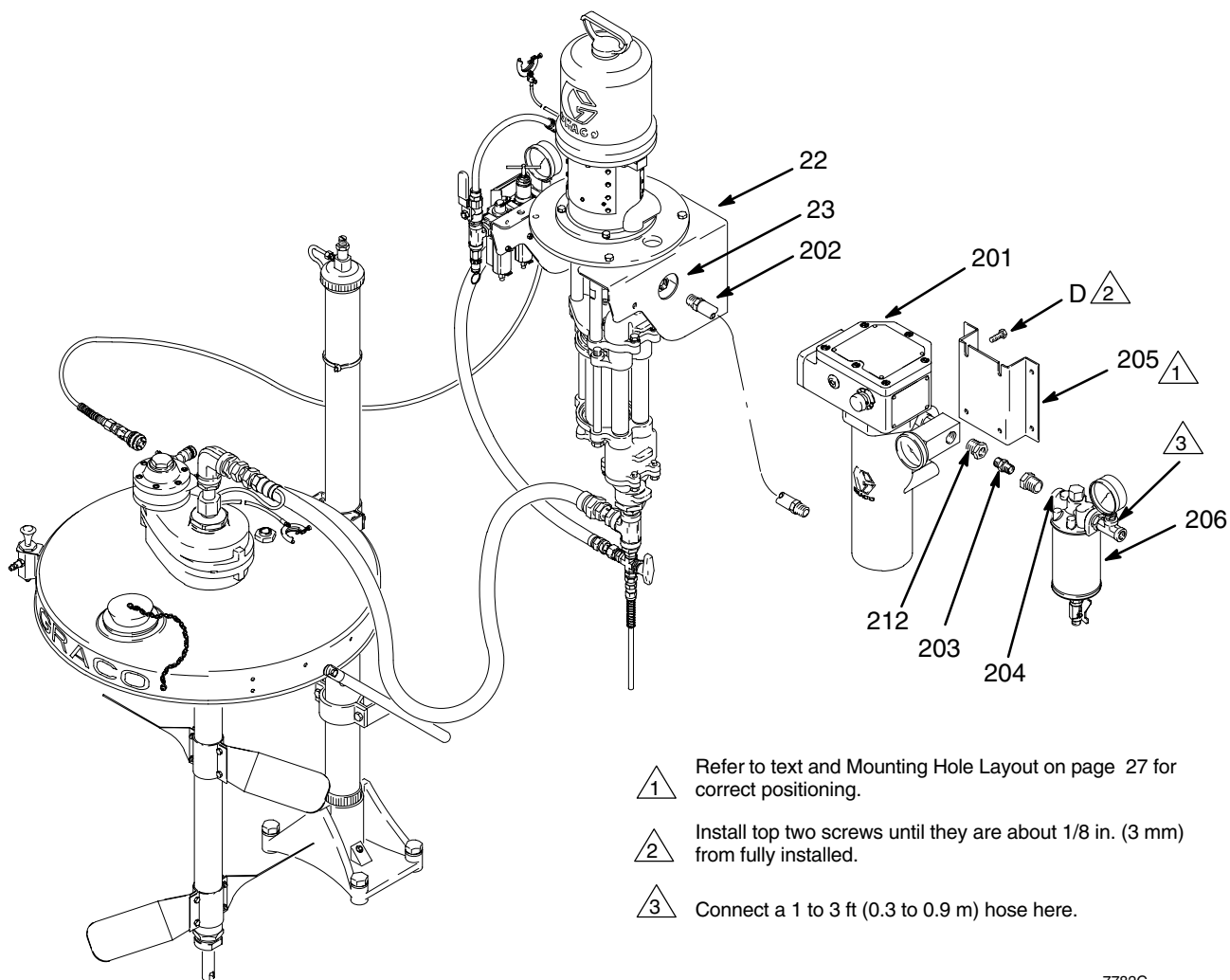

Fig. 3

7782C

Installation

Grounding

⚠ WARNING

FIRE, EXPLOSION, AND ELECTRIC SHOCK HAZARD

Before operating the pump, ground the system as explained below. Also read the section **FIRE, EXPLOSION, AND ELECTRIC SHOCK HAZARD** on page 4.



1. *Pump*: use the ground wire and clamp (40, supplied). See Fig. 4. Loosen the grounding lug locknut (W) and washer (X). Insert one end of the ground wire (40) into the slot in lug (Z) and tighten the locknut securely. Connect the ground clamp to a true earth ground.

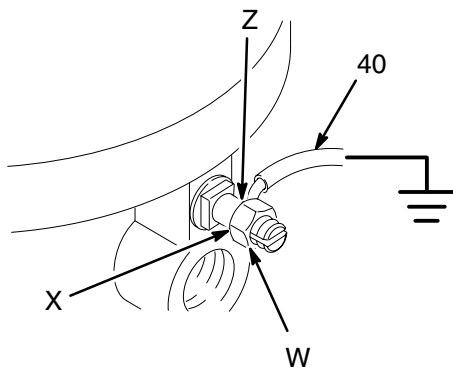
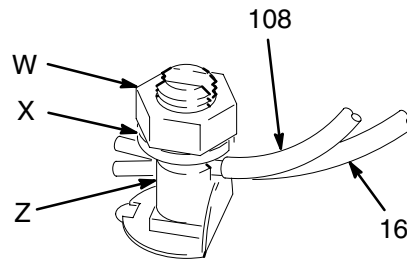

Fig. 4

0720

2. *Air and fluid hoses*: use only electrically conductive hoses.
3. *Air compressor*: follow manufacturer's recommendations.

4. *Viscon HP Heater*: refer to the heater manual, supplied.
5. *Spray gun*: ground through connection to a properly grounded fluid hose and pump.
6. *Agitator*: use the ground wire and clamp (108, supplied). See Fig. 5. Loosen the grounding lug locknut (W) and washer (X). Insert one end of the ground wire (108) into the slot in lug (Z) and tighten the locknut securely. Connect the ground clamp to a true earth ground.



0720

Fig. 5

7. *Suction hose*: attach the hose (16) ground wire to the ground lug on the agitator. See Fig. 5. If you are not using an agitator, attach the wire to the fluid supply container.
8. *Fluid supply container*: follow your local code.
9. *Object being sprayed*: follow your local code.
10. *Solvent pails used when flushing*: follow your local code. Use only metal pails, which are conductive, placed on a grounded surface. Do not place the pail on a nonconductive surface, such as paper or cardboard, which interrupts the grounding continuity.
11. *To maintain grounding continuity when flushing or relieving pressure*, hold a metal part of the spray gun firmly to the side of a grounded *metal* pail, then trigger the gun.

Operation

Pressure Relief Procedure

WARNING

PRESSURIZED EQUIPMENT HAZARD

The system pressure must be manually relieved to prevent the system from starting or spraying accidentally. To reduce the risk of an injury from accidental spray from the gun, splashing fluid, or moving parts, follow the **Pressure Relief Procedure** whenever you:

- are instructed to relieve the pressure,
- stop spraying,
- check or service any of the system equipment,
- or install or clean the spray nozzle.

WARNING



HOT SURFACE HAZARD

Do not touch the heater while it is operating. Allow the heater to cool for at least 10 minutes before flushing or servicing it.

WARNING



FIRE AND EXPLOSION HAZARD

Do not plug in or unplug a power cord in any area containing flammable fluids or fumes, to avoid fire or explosion resulting in serious injury.

1. Disconnect the electric power to the heater (201).
2. Circulate the fluid for at least 10 minutes to cool the heated fluid and the heater.
3. Close the red-handled bleed-type master air valve (11h, required in your system). See Fig. 6.

4. Place the drain hose (42) into a waste container. Turn the 3-way recirculation valve (19) to the drain position.
5. Trigger the gun at the last gun station to relieve fluid pressure. Maintain firm metal-to-metal contact between the gun and a grounded waste pail. Repeat for all gun stations.
6. Open the drain valve (208) to relieve fluid pressure which may be trapped in the pump or hose.

If you suspect that pressure is not fully relieved after following the steps above, wrap a fitting near the pump outlet with a rag, and slowly and carefully loosen the fitting to relieve pressure. Be careful to protect your eyes from splashing.

Packing Nut

Before starting, fill the packing nut (H) 1/3 full with Graco Throat Seal Liquid (TSL) or compatible solvent. See Fig. 6.

WARNING

To reduce the risk of serious injury whenever you are instructed to relieve pressure, always follow the **Pressure Relief Procedure** at left.

The packing nut is torqued at the factory and is ready for operation. If it becomes loose and there is leaking from the throat packings, relieve pressure, then torque the nut to 34–40 N•m (25–30 ft-lb). Do this whenever necessary. Do not overtighten the packing nut.

Flush the Pump Before First Use

The pump is tested with lightweight oil, which is left in to protect the pump parts. If the fluid you are using may be contaminated by the oil, flush it out with a compatible solvent. See **Flushing** on page 18.

Operation

Prime the Pump

1. Disconnect the electric power to the heater before priming the pump.
2. Open the fluid shutoff valve (14).
3. Open the back pressure regulator (12). Turn the 3-way recirculation valve (19) to the circulation position.
4. Open the spray gun at the last gun station and keep it open while starting the pump.
5. Open the bleed-type master air valves (11h, B).
6. Slowly open the air filter/regulator (11a) until the pump starts. The air filter/regulator controls the pump speed and fluid outlet pressure.
7. When fluid comes from the gun, release the gun trigger. The pump will continue to cycle as long as air is supplied and the back pressure regulator (12) is open.
8. One at a time, open any other guns in the system to purge air from the lines.

NOTE: In a circulating system, the pump will continue to cycle as long as air is supplied and the back pressure regulator is open. In a direct supply system, the pump starts when the gun is opened, and stops when the gun is closed.

WARNING

COMPONENT RUPTURE HAZARD

 To reduce the risk of overpressurizing your system, which could cause component rupture and serious injury, *never exceed the specified maximum air input pressure to the package* (see **Technical Data** on page 25).

CAUTION

Do not allow the pump to run dry. It will quickly accelerate to a high speed, causing damage. If your pump is running too fast, stop it immediately and check the fluid supply. If the container is empty and air has been pumped into the lines, refill the container and prime the pump and the lines, or flush and leave it filled with a compatible solvent. Eliminate all air from the fluid system.

Adjust the Spray Pattern

1. Start the pump. Connect the electric power to the heater. Turn the 3-way recirculation valve (19) to the circulation position.
2. Set the heater control to a trial point (4 or 5).
3. Circulate fluid through the pump for at least 10 minutes, at very low pressure. Check the temperature on the heater thermometer.
4. Adjust the fluid pressure and temperature to the lowest settings necessary to get the desired results. Use the air filter/regulator (11a) and the back pressure regulator (12) to adjust the pump speed and fluid pressure until the spray is completely atomized. Refer to the back pressure valve and heater manuals (supplied) for adjustment procedures. Higher pressures and temperatures may not improve the spray pattern and will cause premature component wear.
5. To adjust the spray pattern, follow the complete instructions in your gun manual.

WARNING

COMPONENT RUPTURE HAZARD

 To reduce the risk of overpressurizing your package, which could cause component rupture and serious injury, *never exceed 100 psi (0.7 MPa, 7 bar) air input pressure to the package*. Also refer to the **Technical Data** section on page 25 and to your separate component manuals.

Heat causes fluid to expand. If the heated fluid is trapped with nowhere to expand, it can cause component rupture. **Be sure** to keep the heated fluid circulating by turning the 3-way recirculation valve (19) to the circulation position. **Do not** install a fluid shutoff device between the heater and the gun.

Operation

Elevator Operation

1. To raise the elevator (150), connect the quick coupler (124) on the end of the coiled hose (105) to the male fitting (J) on the air control valve (K). Pull up the air control valve button to raise the elevator to its full height.

WARNING



MOVING PARTS HAZARD

Moving parts can pinch or amputate your fingers. When raising or lowering the elevator, keep your fingers and hands away from the elevator (150), cover support (125), drum cover (114), and lip of the drum.

Do not remove the quick coupler (124) from the male fitting (J) until the elevator is completely lowered.

2. Position a full drum under the drum cover (114).
3. To lower the elevator (150), press down the air control valve (K) button. Lower the elevator until the cover (114) rests properly on the lip of the drum. Disconnect the quick coupler (124) from the male fitting (J).
4. Refer to manual 306287 for further elevator operating instructions.

Agitator Operation

1. Close the agitator's needle valve (L).
2. Connect the quick coupler (124) on the end of the coiled hose (105) to the male fitting (M) on the agitator (102).

3. Slowly open the needle valve (L) to start the agitator (102). Use the valve to adjust the speed. Do not operate the agitator too fast. If the fluid foams or a vortex forms on the fluid surface, reduce the speed of the agitator.
4. Refer to manual 308609 for further agitator operating instructions.

Shutdown

WARNING

To reduce the risk of serious injury whenever you are instructed to relieve pressure, always follow the **Pressure Relief Procedure** on page 14.

1. Lower the elevator (150).
2. Shut off the agitator (102).
3. Relieve the pressure.

For overnight shutdown, stop the pump at the bottom of its stroke to prevent fluid from drying on the exposed displacement rod and damaging the throat packings. Relieve the pressure.

Always flush the pump before the fluid dries on the displacement rod. See **Flushing** on page 18.

NOTE: When changing fluid containers with the hose and gun already primed, open the drain valve (208) to help prime the pump and vent air before it enters the hose. Close the drain valve when all air is eliminated.

Maintenance

Preventive Maintenance Schedule

The operating conditions of your particular system determine how often maintenance is required. Establish a preventive maintenance schedule by recording when and what kind of maintenance is needed, and then determine a regular schedule for checking your system.

Flushing

⚠ WARNING



FIRE, EXPLOSION, AND ELECTRIC SHOCK HAZARD

Before operating the pump, ground the system as explained below. Also read the section **FIRE, EXPLOSION, AND ELECTRIC SHOCK HAZARD** on page 4.

Flush the pump:

- Before the first use
- When changing colors or fluids
- Before fluid can dry or settle out in a dormant pump (check the pot life of catalyzed fluids)
- Before storing the pump.

Flush with a fluid that is compatible with the fluid you are pumping and with the wetted parts in your system. Check with your fluid manufacturer or supplier for recommended flushing fluids and flushing frequency.

⚠ WARNING

To reduce the risk of serious injury whenever you are instructed to relieve pressure, always follow the **Pressure Relief Procedure** on page 14.

1. Relieve the pressure.
2. Remove the air cap and spray tip from the gun. See the gun manual.
3. Remove the filter element from the fluid filter (206). Reinstall the filter bowl.
4. Open the back pressure regulator (12). Set the 3-way recirculation valve (19) to the circulation position.

5. Lower the agitator (102) into a container of solvent. Start the agitator and run it slowly.
6. Hold a metal part of the gun firmly to the side of a grounded *metal* pail.
7. Start the pump. Always use the lowest possible fluid pressure when flushing.
8. Trigger the gun. Flush the system until clear solvent flows from the gun.
9. Release the gun trigger and lock the trigger safety. The pump will continue to cycle as long as air is supplied and the back pressure regulator (12) is open.
10. Direct the drain hose (42) into a waste container. Set the 3-way recirculation valve (19) to the drain position. Continue flushing until clear fluid comes from the hose.
11. Relieve the pressure.
12. Clean the air cap, spray tip, and fluid filter element separately, then reinstall them.

Air Filter Service

Repair Kits are available. Refer to page 19.

Every day, drain contaminants from the bowl before reaching the baffle level by opening the drain (P) at the bottom of the bowl (N).

⚠ WARNING

To reduce the risk of serious injury whenever you are instructed to relieve pressure, always follow the **Pressure Relief Procedure** on page 14.

Clean the air filter regularly to maximize filtering efficiency and to avoid excessive pressure drop. Fully relieve pressure to remove the bowl (N).

Clean the filter element (311) and bowl using household soap and water or denatured alcohol. Use compressed air to blow out the filter body. Blow the filter element out from the inside.

Clean the sight glass (309) thoroughly. Do not leave solvent residue in the sight glass as it may attack or weaken the glass. If the sight glass appears damaged, replace it immediately.

Maintenance

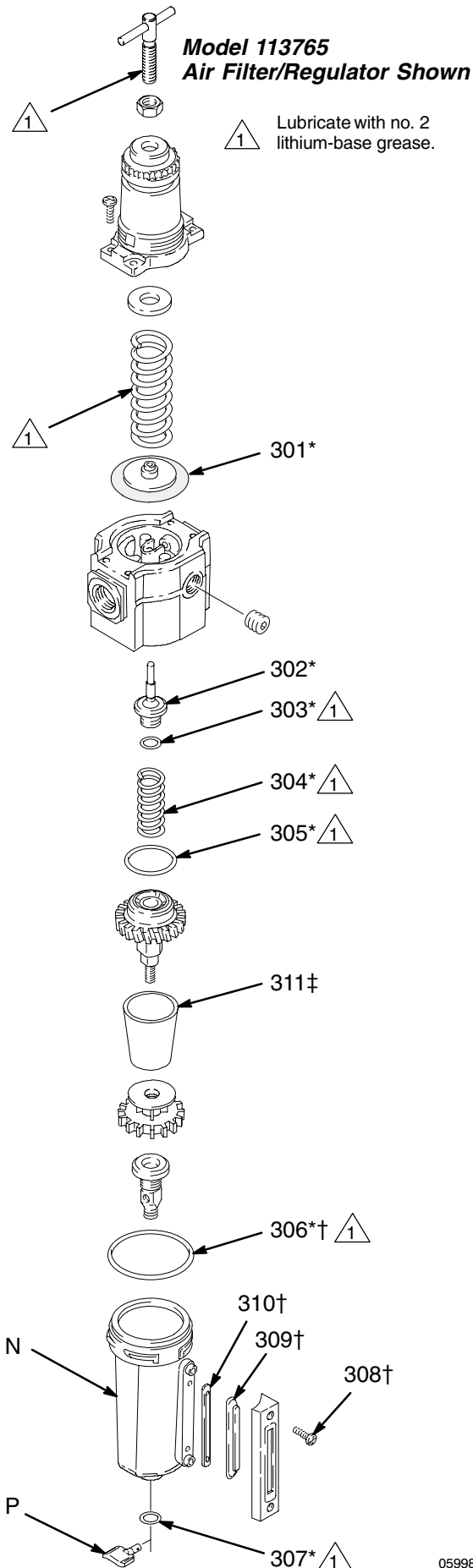

Repair Kit 239383 (includes items 301 to 307). For Part No. 113765 Air Filter/Regulator.

Kit parts are marked with an asterisk (301*). Individual parts are not available separately.

Ref. No.	Part No.	Description	Qty.
301*	N/A	DIAPHRAGM	1
302*	N/A	VALVE ASSEMBLY	1
303*	N/A	O-RING, valve	1
304*	N/A	SPRING, valve	1
305*	N/A	O-RING, center post	1
306*	N/A	O-RING, bowl assembly	1
307*	N/A	GASKET, drain	1

Sight Glass Kit 239385 (includes items 306 to 310). For Part No. 113765 Air Filter/Regulator.

Kit parts are marked with a symbol (308†). Individual parts are not available separately.

Ref. No.	Part No.	Description	Qty.
306†	N/A	O-RING, bowl assembly	1
308†	N/A	SCREW	2
309†	N/A	LENS, sight glass	1
310†	N/A	SEAL, lens	1

Filter Element Kit 239384 (includes item 311). For Part No. 113765 Air Filter/Regulator.

Kit parts are marked with a symbol (311‡). Individual parts are not available separately.

Ref. No.	Part No.	Description	Qty.
311‡	N/A	ELEMENT, 40 micron; polypropylene	1

Parts

Pump Module Parts

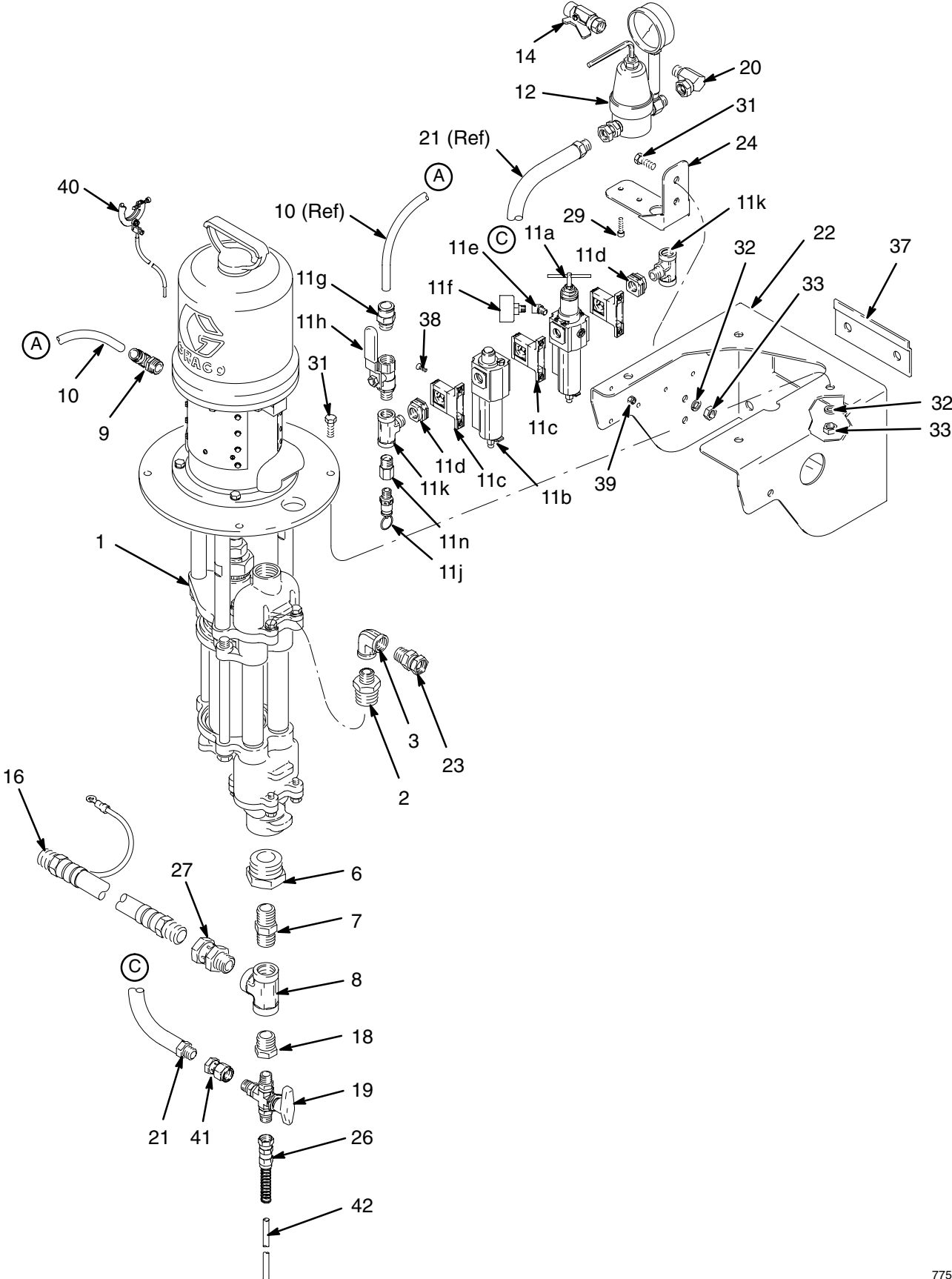

7756B

Parts

Pump Module Parts

Ref. No.	Part No.	Description	Qty.	Ref. No.	Part No.	Description	Qty.
1	239854	PUMP, President; 3:1 ratio; stainless steel; see manual 308793	1	16	221171	HOSE, suction, with ground wire; nylon; 3/4 npt(mbe) stainless steel couplings; 1/2 in. (13 mm) ID; 6 ft (1.8 m) long	1
2	503086	NIPPLE, reducing; stainless steel; 1 in. x 1/2 npt	1	18	500352	BUSHING; stainless steel; 3/4 npt(m) x 3/8 npt(f)	1
3	500947	ELBOW, 90°; stainless steel; 1/2 npt(fbe)	1	19	114189	VALVE, recirculation, 3-way; stainless steel; 3/8 npt(m)	1
6	114188	BUSHING; stainless steel; 11/2 in. npt(m) x 3/4 npt(f)	1	20	207123	SWIVEL, 90°; stainless steel; 3/8 npt(m) x 3/8 npsm(f)	1
7	510073	NIPPLE; stainless steel; 3/4 npt	1	21	114198	HOSE, fluid return; nylon; 3/8 npt(mbe) stainless steel couplings; 1/4 in. (6 mm) ID; 6 ft (1.8 m) long	1
8	113833	TEE; stainless steel; 3/4 npt(f) run x 3/4 npt(f) branch	1	22	192584	BRACKET, pump	1
9	114110	ELBOW, tube fitting, 90°; 1/2 npt(m) x 1/2 in. (13 mm) OD tube	1	23	114190	UNION, swivel; 1/2 npt(m) x 1/2 npsm(f); stainless steel	1
10	buy locally	HOSE; polyurethane; 0.328 in. (8 mm) ID; 13 in. (330 mm) long	1	24	192586	BRACKET, back pressure regulator	1
11	239849	AIR FILTER/REGULATOR/LUBRICATOR; <i>includes items 11a to 11n</i>	1	26	111914	COUPLING, hose, with spring guard; stainless steel; 3/8 npsm(f)	1
11a	113765	• AIR FILTER/REGULATOR	1	27	112268	SWIVEL; 3/4 npt (m x f); stainless steel	1
11b	114005	• LUBRICATOR	1	29	101550	SCREW, cap, socket hd; 1/4–20; 1/2 in. (13 mm) long	2
11c	113763	• CONNECTOR, quick	3	31	102471	SCREW, cap, hex head; 3/8–16 x 1 in. (25 mm) long	5
11d	113767	• ADAPTER, pipe; 3/8 npt(f)	2	32	112922	LOCKWASHER, spring; 3/8	5
11e	113760	• ELBOW, 45°; 1/8 npt (m x f)	1	33	112913	NUT, hex; 3/8–16	5
11f	113911	• GAUGE, air	1	37	192589	PLATE, mounting, bracket	1
11g	114129	• ADAPTER, tube fitting; 1/2 npt(m) x 1/2 in. (13 mm) OD tube	1	38	113768	SCREW, machine, socket, flat head; M5 x 0.8; 16 mm long	6
11h	113333	• VALVE, ball, bleed-type; 3/8 npt (m x f)	1	39	105332	NUT, hex, with nylon insert; M5 x 0.8	6
11j	113498	• VALVE, relief; 110 psi (7.6 bar, 0.76 MPa)	1	40	237569	GROUND WIRE AND CLAMP	1
11k	113777	• TEE; 3/8 npt(f) run x 3/8 npt(m) branch	2	41	207152	SWIVEL, straight; 3/8 npt(f) x 3/8 npsm(f)	1
11n	159841	• ADAPTER; 3/8 npt(m) x 1/4 npt(f)	1	42	buy locally	TUBE; nylon; 1/4 in. (6 mm) ID; 8 in. (203 mm) long	1
12	236770	REGULATOR, back pressure; see manual 308401	1	49	206994	THROAT SEAL LIQUID; 1 pint (0.5 liter); not shown	1
14	237532	VALVE, ball; stainless steel; 3/8 npt(fbe); see manual 307068	1				

Parts

Supply Module Parts

1 Pump Module. See page 20 for parts.

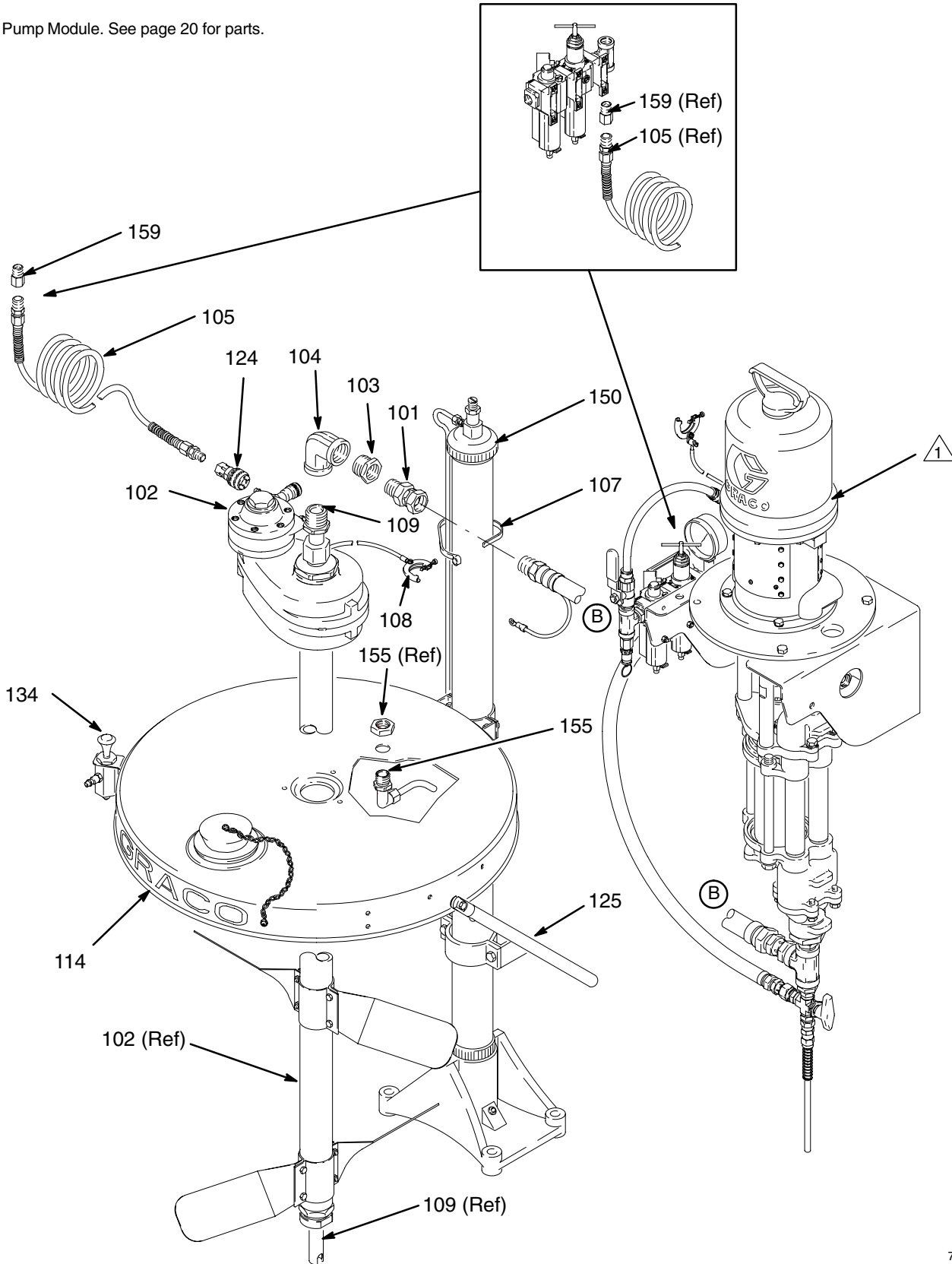

7757B

Parts

Supply Module Parts

Ref. No.	Part No.	Description	Qty.	Ref. No.	Part No.	Description	Qty.
101	112268	SWIVEL; stainless steel; 3/4 npt (m x f)	1				
102	238157	AGITATOR, back-gearred; see manual 308609	1	114	238283	COVER, drum; stainless steel; see manual 308466	1
103	502851	BUSHING; sst; 1 in. npt(m) x 3/4 npt(f)	1	124	208536	COUPLER, quick disconnect, female	1
104	500251	ELBOW, 90°; stainless steel; 1 in. npt (fbe)	1	125	237578	ASSEMBLY, cover support; see manual 306287	1
105	205600	HOSE, air; nylon; 1/4 in. (6 mm) ID; 1/4 npt (mbe); 50 ft (15.2 m) long	1	134	237579	KIT, air control, elevator; see manual 306287	1
107	103546	STRAP, tie	3	150	204385	ELEVATOR, drum; see manual 306287	1
108	237569	GROUND WIRE AND CLAMP	1	155	238884	KIT, return tube	1
109	238250	RISER TUBE KIT; see manual 308609	1	159	159841	ADAPTER; 3/8 npt(m) x 1/4 npt(f)	1

Parts

Part No. 232090, Series A, 3:1 President heated circulation package

1 Pump Module. See page 20 for parts.

2 Supply Module. See page 22 for parts.

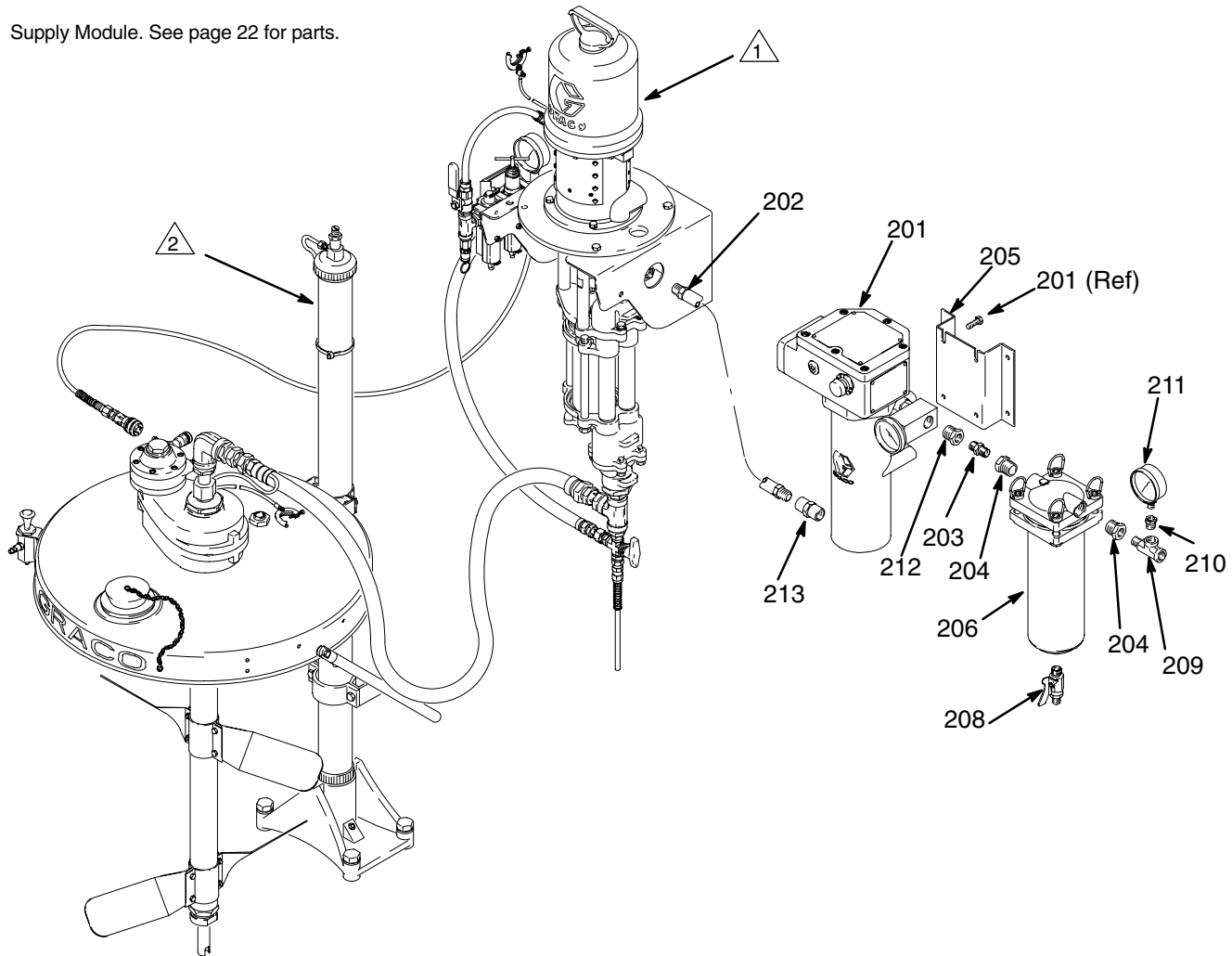

7758D

Ref. No.	Part No.	Description	Qty.	Ref. No.	Part No.	Description	Qty.
201	245848	HEATER, fluid, 120V; see manual 309524	1	208	237529	VALVE, ball; stainless steel; 1/4 npt x 3/8 npsm (mbe); see manual 307068	1
202	114253	HOSE, supply, heater; nylon; 1/2 in. (13 mm) ID; 1/2 npt(mbe) sst couplings; 2 ft (0.61 m)	1	209	108673	TEE; stainless steel; 3/8 npt(f) x 3/8 npt(m) run; 3/8 npt(f) branch	1
203	111873	NIPPLE; 3/8 npt; stainless steel	1	210	168160	BUSHING; stainless steel; 3/8 npt(m) x 1/4 npt(f)	1
204	500352	BUSHING; 3/4 npt(m) x 3/8 npt(f); stainless steel	1	211	187876	GAUGE, fluid pressure; stainless steel; 1 0-300 psi (0-21 bar, 0-2.1 MPa)	1
205	192585	BRACKET, heater	1	212	502265	BUSHING, reducer, pipe	1
206	244053	FLUID FILTER; stainless steel	1	213	117627	FITTING, coupler	1

Technical Data

Part No. 232090, Series A, 3:1 President heated circulation package

Category	Data
Maximum fluid working pressure	300 psi (2.1 MPa, 21 bar)
Maximum air input pressure	100 psi (0.7 MPa, 7 bar)
Ratio	3:1
Maximum heater voltage and amperage	120 VAC, 19.2 Ampere
Maximum operating temperature	150°F (66°C)
Weight	114 lb (52.7 kg)
Wetted parts	<i>Pump:</i> See pump manual 308793. <i>Fluid Heater:</i> See heater manual 309524. <i>Back Pressure Regulator:</i> See back pressure regulator manual 308401. <i>Fluid Filter:</i> See filter manual 308918. <i>Back-Geared Agitator:</i> See agitator manual 308609. <i>Fluid Hoses:</i> Nylon

Sound Pressure Levels (dBa) (measured at 1 meter from unit)

Air Motor	Input Air Pressures at 15 cycles per minute		
	40 psi (0.28 MPa, 2.8 bar)	70 psi (0.48 MPa, 4.8 bar)	100 psi (0.7 MPa, 7 bar)
President	73.6 dB(A)	78.3 dB(A)	80.9 dB(A)

Sound Power Levels (dBa) (tested in accordance with ISO 9614-2)

Air Motor	Input Air Pressures at 15 cycles per minute		
	40 psi (0.28 MPa, 2.8 bar)	70 psi (0.48 MPa, 4.8 bar)	100 psi (0.7 MPa, 7 bar)
President	87.4 dB(A)	92.1 dB(A)	94.6 dB(A)

Performance Chart

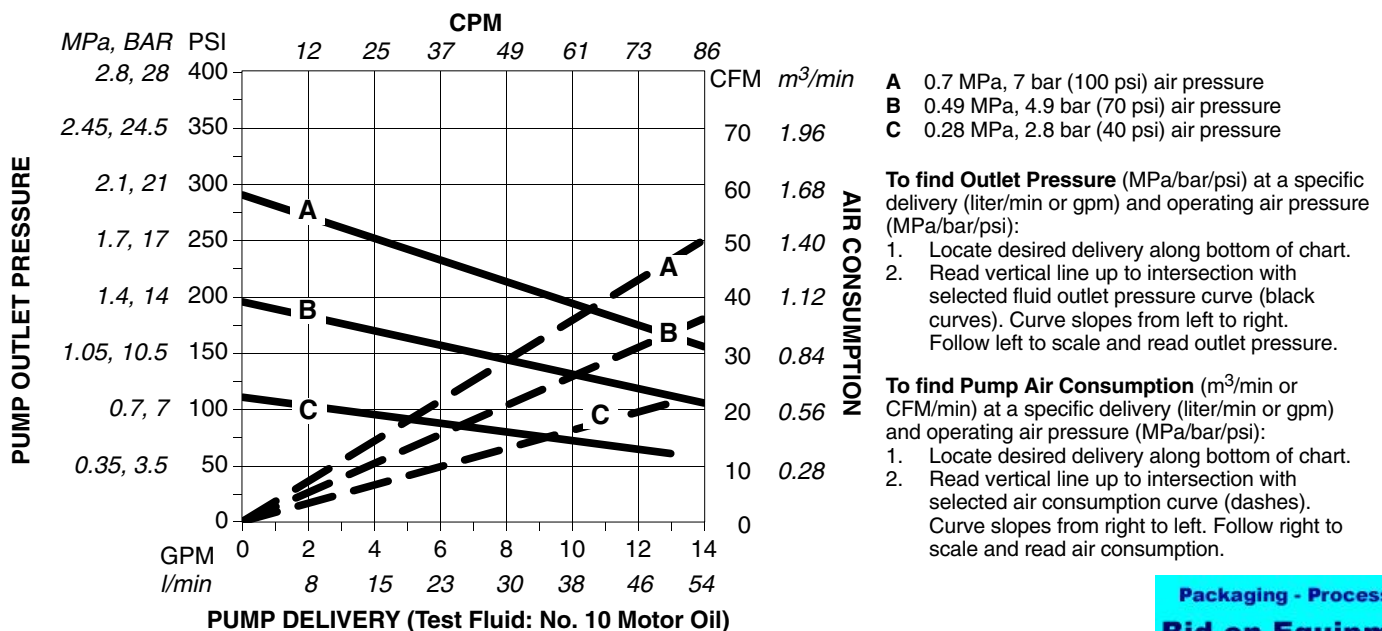

Dimensions

- 1 Ensure that there is 9 ft (2.8 m) overhead clearance for the elevator when fully raised.
- 2 Mount the pump module so the top of the bracket is 4 to 5 ft (1.2 to 1.5 m) above the floor.
- 3 The suction hose is 6 ft (1.8 m) long. Do not stretch the hose tight; let it hang as shown, to assist fluid flow into the pump.

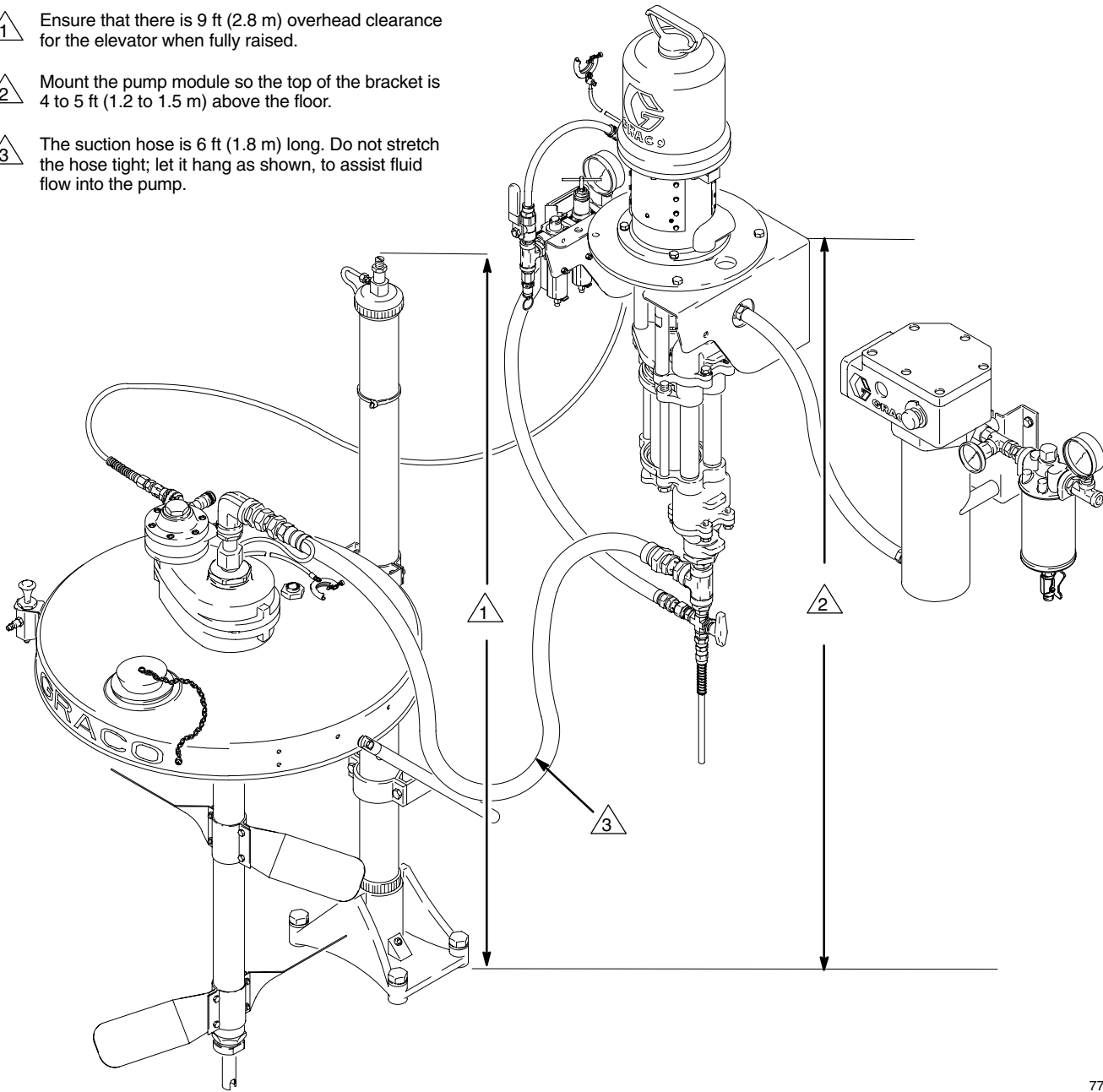

7759B

Mounting Hole Layouts

- 1 Check that the bracket is level before bolting it to the wall.
- 2 Mount the bracket so the top edge is 4 to 5 ft (1.2 to 1.5 m) above the floor.
- 3 Slots must face up..

Pump Wall Bracket Mounting Diagram

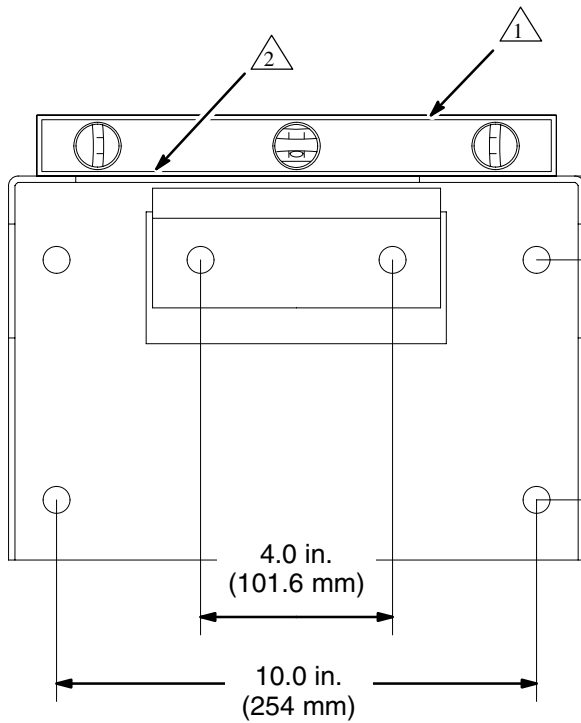

Heater Wall Bracket Mounting Diagram

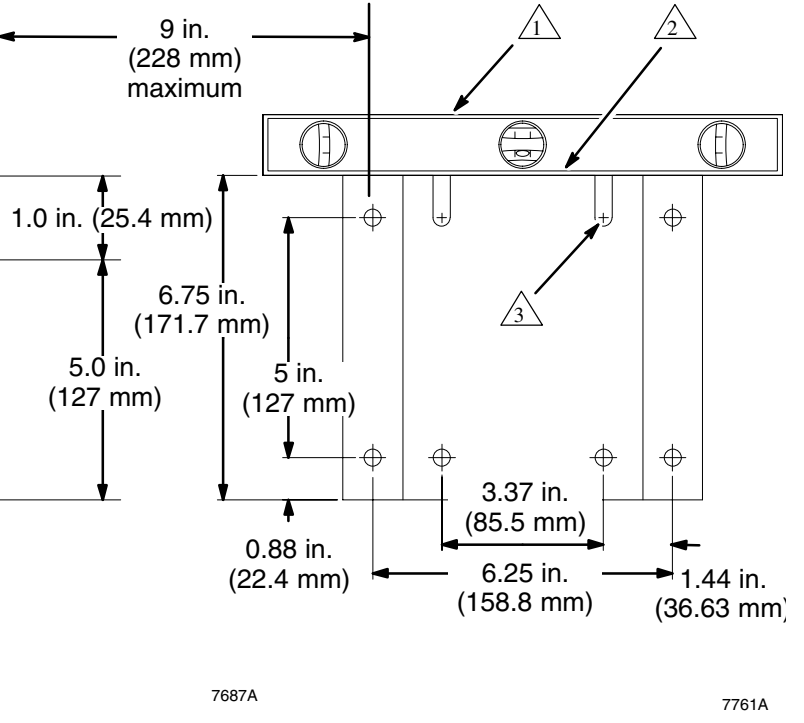

7687A

7761A

Elevator Base Mounting Diagram

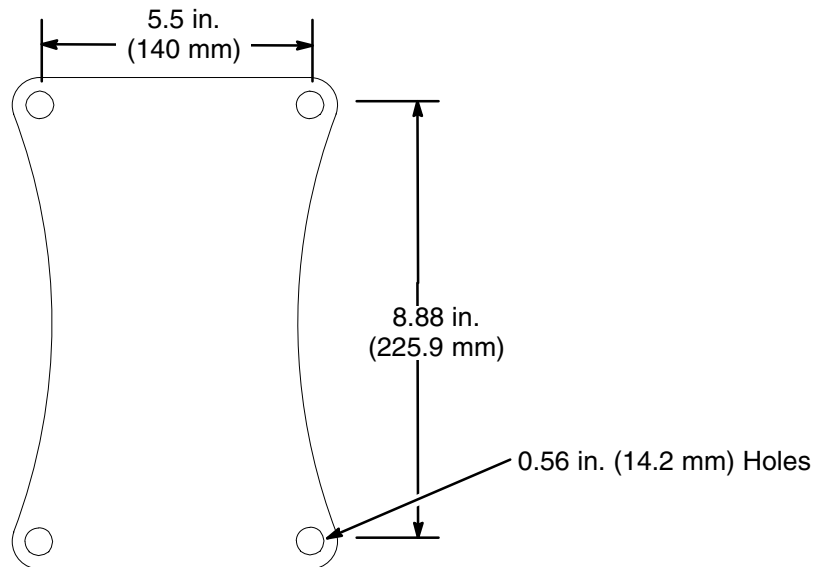

06533