

Instructions – Parts List



55 GALLON SUPPLY PUMPS

3:1 President[®], 4:1 President[®], and 2:1 Monark[®]

307745G

With drum cover and agitator

Model 220575, Series B

with 3:1 Ratio President Pump

500 psi (3.5 MPa, 35 bar) MAXIMUM FLUID WORKING PRESSURE

* Model 230992, Series C

with 4:1 Ratio President Pump

400 psi (2.8 MPa, 28 bar) MAXIMUM FLUID WORKING PRESSURE

Model 230993, Series C

with 2:1 Ratio Monark Pump

200 psi (1.4 MPa, 14.0 bar) MAXIMUM FLUID WORKING PRESSURE

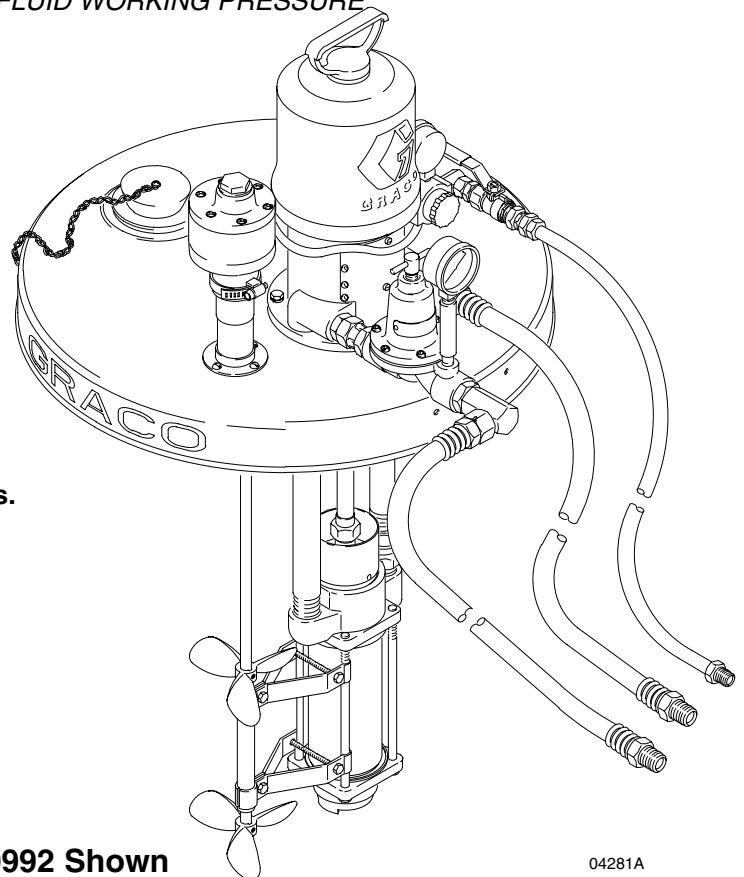

Read warnings and instructions.
See page 2 for table of contents.

Model 230992 Shown

04281A

PROVEN QUALITY. LEADING TECHNOLOGY.

GRACO INC. P.O. BOX 1441 MINNEAPOLIS, MN 55440-1441
Copyright 1985, Graco Inc. is registered to I.S. EN ISO 9001



HO03

Packaging - Processing
Bid on Equipment
1-847-683-7720
www.bid-on-equipment.com

Table of Contents

Warnings	2	Adjusting the Unit	8
Setup		Starting and Adjusting the Pump	8
Grounding	5	Shutdown and Care of the Pump	9
Positioning the Unit	5	Parts Drawing	10
System Accessories	5	Parts List	11
Connecting the Unit and Accessories	6	Technical Data	15
Operation		Warranty	16
Pressure Relief Procedure	7	Graco Information	16
Flushing	7		

Symbols

Warning Symbol



This symbol alerts you to the possibility of serious injury or death if you do not follow the instructions.

Caution Symbol



This symbol alerts you to the possibility of damage to or destruction of equipment if you do not follow the instructions.

WARNING

 <small>INSTRUCTIONS</small>	<p>EQUIPMENT MISUSE HAZARD</p> <p>Equipment misuse can cause the equipment to rupture or malfunction and result in serious injury.</p> <ul style="list-style-type: none"> ● This equipment is for professional use only. ● Read all instruction manuals, tags, and labels before operating the equipment. ● Use the equipment only for its intended purpose. If you are not sure, call your Graco distributor. ● Do not alter or modify this equipment. Use only genuine Graco parts and accessories. ● Check equipment daily. Repair or replace worn or damaged parts immediately. ● Do not exceed the maximum working pressure of the lowest rated system component. See Technical Data on page 15 for the maximum working pressure of this equipment. ● Use fluids and solvents that are compatible with the equipment wetted parts. Refer to the Technical Data section of all equipment manuals. Read the fluid and solvent manufacturer's warnings. ● Do not use hoses to pull equipment. ● Route hoses away from traffic areas, sharp edges, moving parts, and hot surfaces. Do not expose Graco hoses to temperatures above 180°F (82°C) or below -40°F (-40°C). ● Wear hearing protection when operating this equipment. ● Do not lift pressurized equipment. ● Comply with all applicable local, state, and national fire, electrical, and safety regulations.
---------------------------------	---

WARNING



MOVING PARTS HAZARD

- The air motor piston can pinch or amputate your fingers.
- The rotating blades of the agitator can pinch or amputate your fingers or other body parts and can cause splashing in the eyes or on the skin.
- Always shut off the agitator and disconnect the air line before adjusting the angle of the agitator, removing the agitator from the drum, or checking or repairing any part of the agitator.
- Keep clear of all moving parts when starting or operating the equipment.
- Before servicing the equipment, follow the **Pressure Relief Procedure** on page 7 to prevent the equipment from starting unexpectedly.

WARNING



FIRE AND EXPLOSION HAZARD

Improper grounding, poor ventilation, open flames or sparks can cause a hazardous condition and result in a fire or explosion and serious injury.

- Ground the equipment and the object being sprayed. Refer to **Grounding** on page 5.
- If there is any static sparking or you feel an electric shock while using this equipment, **stop spraying immediately**. Do not use the equipment until you identify and correct the problem.
- Provide fresh air ventilation to avoid the buildup of flammable fumes from solvents or the fluid being sprayed.
- Keep the spray area free of debris, including solvent, rags, and gasoline.
- Electrically disconnect all equipment in the spray area.
- Extinguish all open flames or pilot lights in the spray area.
- Do not smoke in the spray area.
- Do not turn on or off any light switches in the spray area while operating or if fumes are present.
- Do not operate a gasoline engine in the spray area.



TOXIC FLUID HAZARD

Hazardous fluid or toxic fumes can cause serious injury or death if splashed in the eyes or on the skin, inhaled, or swallowed.

- Know the specific hazards of the fluid you are using.
- Store hazardous fluid in an approved container. Dispose of hazardous fluid according to all local, state and national guidelines.
- Always wear protective eyewear, gloves, clothing, and respirator as recommended by the fluid and solvent manufacturer.

Setup

NOTES:

- Reference numbers and letters in parentheses in the text refer to the callouts in the figures and the parts drawing.
- Accessories are available from your Graco representative. If you supply your own accessories, be sure they are adequately sized and pressure-rated to meet the system's requirements.

Grounding

⚠ WARNING



FIRE AND EXPLOSION HAZARD
Before operating the pump, ground the system as explained below. Also read the section **FIRE AND EXPLOSION HAZARD** on page 4.

Proper grounding is an essential part of maintaining a safe system.

To reduce the risk of static sparking, the mounting cover and all electrically conductive objects or devices in the spray area **must** be properly grounded. Check your local electrical code for detailed grounding instructions for your area and type of equipment.

Agitator and drum cover: Connect one end of the ground wire (Y) to the ground connector (X) on the rim of the drum cover. See Fig. 1. Connect the other end of the ground wire to a true earth ground. See the pump instruction manual (307986 for 230992, 307985 for model 230993, or 308793 for model 220575) for instructions on grounding the pump.

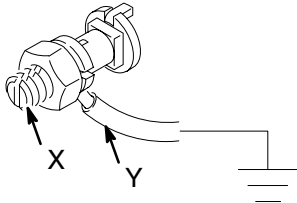

Fig. 1

Air and fluid hoses: Use only electrically conductive hoses with 500 ft. (150 m) maximum combined hose length to ensure grounding continuity.

Air compressor: Follow manufacturer's recommendations.

Spray gun or dispensing valve: Ground through connection to a properly grounded fluid hose and pump.

Object being sprayed: Follow your local code.

Fluid supply container: Follow your local code.

Solvent pails used when flushing: Follow your local code. Use only metal pails, which are conductive, placed on a grounded surface. Do not place the pail on a nonconductive surface, such as paper or cardboard, which interrupts the grounding continuity.

To maintain proper grounding continuity when flushing or relieving pressure, always hold the metal part of the spray gun firmly to the side of a grounded metal pail, then trigger the gun.

Positioning the Unit

Select a convenient location for the unit. The air valves for the pump (37) and agitator (5) must be fully accessible.

System Accessories

⚠ WARNING

A bleed-type master air valve (N) and a fluid drain valve (K) are required in your system. These accessories help reduce the risk of serious injury, including splashing of fluid in the eyes or on the skin, and injury from moving parts if you are adjusting or repairing the pump or agitator.

The bleed-type master air valve relieves air trapped between this valve and the pump after the air is shut off. Trapped air can cause the pump to cycle unexpectedly. Locate the valve close to the pump. A red-handled bleed-type ball valve is supplied to relieve air trapped in the air motor.

The fluid drain valve assists in relieving fluid pressure in the displacement pump, hose, and gun. Triggering the gun to relieve pressure may not be sufficient. Order Part No. 210071.

Setup

The installation shown in Fig. 2 is only a guide for selecting and installing system components and accessories. Contact your Graco representative for assistance in designing a system to suit your particular needs.

Connecting the Unit and Accessories

- Ground the unit as described in **Grounding** on page 5.
- The main air supply must include a bleed-type master air valve (N) for shutting off air pressure to the unit (supplied with Model 230992).
- Connect a grounded air supply hose to the bleed type pump air valve (N).
- The fluid line must include a fluid drain valve (K), which helps relieve fluid pressure in the hose and gun.
- You should install an air line filter (J) to remove dirt and moisture from the air supply.
- Downstream from the air filter, you should install an air line lubricator (H) for automatic air motor lubrication.

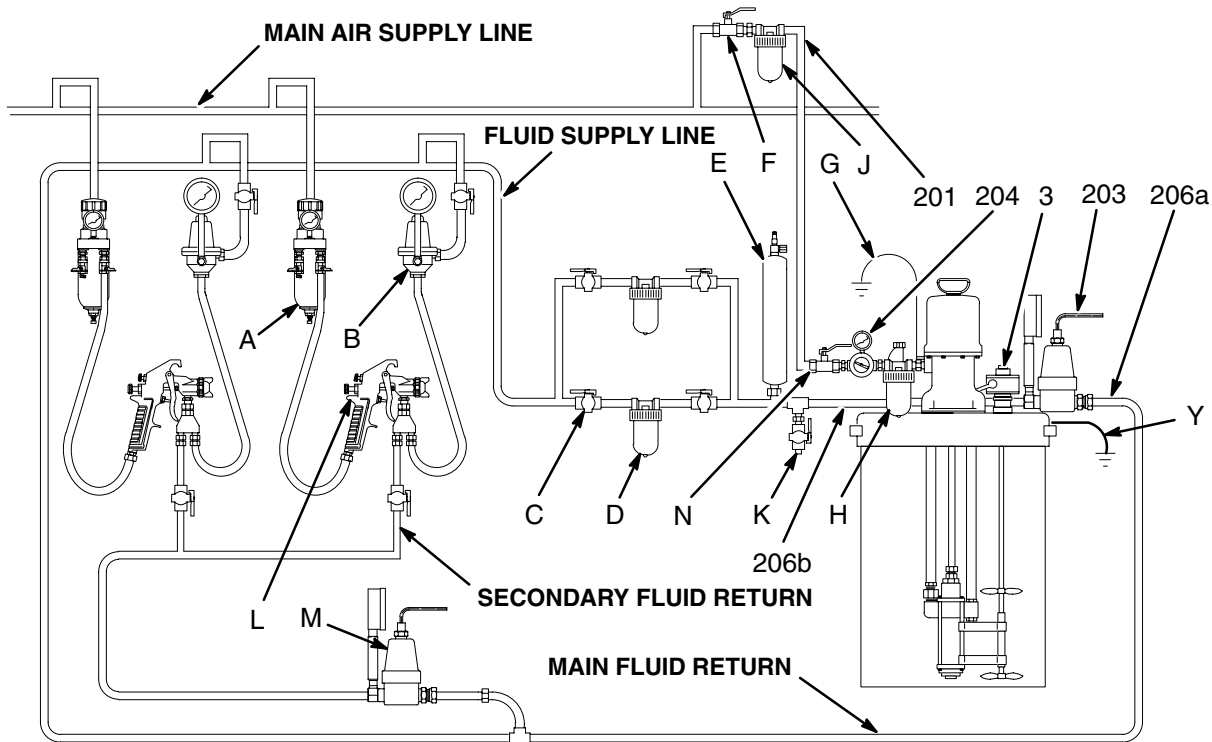

KEY

- | | | |
|--------------------------------------|--|--|
| A Air Filter/Regulator to Gun | H Air Line Lubricator | Y Drum Cover/Agitator Ground Wire |
| B Fluid Pressure Regulator | J Air Filter to Pump | 3 Agitator |
| C Fluid Shutoff Valve | K Drain Valve | 201 Air Supply Hose |
| D Fluid Filter | L Air Spray Circulating Gun | 203 Back Pressure Valve |
| E Surge Tank | M Back Pressure Valve | 204 Air Regulator |
| F Bleed-type Master Air Valve | (same as 203 except customer supplied) | 206a Return Fluid Hose |
| G Pump Ground Wire | N Bleed-type Pump Air Valve | 206b Supply Fluid Hose |

Fig. 2

04283A

Operation

Pressure Relief Procedure

WARNING

PRESSURIZED EQUIPMENT HAZARD

The system pressure must be manually relieved to prevent the system from starting or spraying accidentally. To reduce the risk of an injury from accidental spray from the gun, splashing fluid, or moving parts, follow the **Pressure Relief Procedure** whenever you:

- are instructed to relieve the pressure,
- stop spraying,
- check or service any of the system equipment,
- or install or clean the spray nozzle.

1. Lock the gun trigger safety.
2. Shut off the air supply to the pump.
3. Close the bleed-type master air valve (required in your system). On Model 230992, this is the red-handled ball valve, assembled next to the air regulator.
4. Unlock the gun trigger safety.
5. Hold a metal part of the gun firmly to the side of a grounded metal pail, and trigger the gun to relieve pressure.
6. Lock the gun trigger safety.
7. Open the drain valve (required in your system), and have a container ready to catch the drainage.
8. Leave the drain valve open until you are ready to spray again.

If you suspect that the spray tip or hose is completely clogged, or that pressure has not been fully relieved after following the steps above, very slowly loosen the tip guard retaining nut or hose end coupling and relieve the pressure gradually. Then loosen it completely. Then clear the tip or hose.

Flushing

WARNING



FIRE AND EXPLOSION HAZARD

Before flushing, read the section **FIRE AND EXPLOSION HAZARD** on page 4. Be sure the entire system and flushing pails are properly grounded. Refer to **Grounding** on page 5.

Flush the pump before first use. The pump is tested with lightweight oil, which is left in to protect the pump parts. If the fluid you are using may be contaminated by the oil, flush it out with a compatible solvent.

WARNING

To reduce the risk of serious injury whenever you are instructed to relieve pressure, always follow the **Pressure Relief Procedure** at left.

To clean any settled particles out of the system, flush the entire system at least once each 90 days or less. If possible, circulate the solvent and leave it in the lines for two days, such as over the weekend, to help loosen any dried paint.

1. **Relieve the pressure.**
2. Shutdown the system as explained in **Shutdown and Care of the Pump** on page 9.
3. Start the pump and operate it at about 30 cycles per minute.
4. Lubricate the agitator, if you haven't already done so, and then close its air valve to stop agitation.

WARNING

Failure to shut off the agitator before raising the pump assembly may result in serious injury from splashing paint in the eyes or contact with the blades of the agitator.

5. Raise the pump out of the paint while it is still running and let it run itself dry to force the paint back into the drum. Shut off the pump.

CAUTION

Never leave water or water-based fluid in the pump overnight. Flush with a compatible solvent to protect the parts from corrosion.

6. Remove the paint drum and place a 55 gallon drum, containing enough solvent to thoroughly fill and flush the system, under the pump. Lower the pump.
7. Start the pump again and allow the solvent to circulate for at least one hour.

Operation

8. Shut off the air to the pump, open the bleed-type master air valve, and open the drain valve (K). Leave the solvent in the system overnight or, if possible, all weekend.
9. Start the pump and circulate it again for 30 minutes. Raise the pump out of the solvent and let it dry to force out the solvent. Drain solvent from all outlet loops and filters.
10. Place the paint supply drum under the pump, agitate the paint, install the gun and hoses.
11. Reset the air and fluid pressure regulators to complete the system flushing.
5. When the paint returns through the return line in a steady stream, turn on the air to one gun, open both fluid shutoff valves (C) near the gun, and adjust the fluid regulator (B). See the manuals supplied with these components for pressure range and adjustment . Repeat for all gun stations.
6. Paint line pressure is controlled by the back pressure regulator (203). This regulator restricts flow of paint in the line so there is sufficient paint pressure at all gun stations. Turn the regulator handle **clockwise to increase** and **counter-clockwise to decrease** pressure. Adjust the regulator so there is about 10 psi (0.6 bar) more fluid pressure at the regulator than is required at the last gun in the line.

Adjusting the Unit

Install supply drum under cover/pump. Make sure that the cover is supported by the drum.

CAUTION

Shortened or recycled drums may cause the pump or agitator to bottom out in the drum, causing damage. Contact your fluid supplier to order a standard size drum.

1. Unscrew the filter bowl and remove the filter screen. Replace the bowl. Flush the unit until clear solvent comes from the gun, then reinstall the filter screen.
2. Before operation, ensure that all fasteners and tube connections are tightened securely.

Starting and Adjusting the Pump

1. Close the air regulator (204).
2. Start the agitator (3). Agitate the paint just fast enough to keep all paint particles suspended. Over-agitating causes air bubbles in the paint which can cause poor gun performance and poor surface finish.
3. Open the red-handled ball valve. Open the pump's bleed-type master air valve (N).
4. Slowly open the air regulator until the pump starts. Adjust it until the pump cycles slowly – about 50 cycles per minute.

NOTE: As you increase fluid line pressure, you must also increase air pressure to the pump, so the pump can handle the heavier load. However, never increase the pressure so much that you exceed the maximum working pressure of any component in the system.

7. As you start to spray, adjust the air and fluid pressures to the gun to obtain the best results.

CAUTION

Do not allow the pump to run dry. It will quickly accelerate to a high speed, causing damage. If your pump is running too fast, stop it immediately and check the fluid supply. If the container is empty and air has been pumped into the lines, refill the container and prime the pump and the lines, or flush and leave it filled with a compatible solvent. Eliminate all air from the fluid system.

WARNING

COMPONENT RUPTURE HAZARD



To reduce the risk of overpressurizing your system, which could cause component rupture and serious injury, *never exceed the specified Maximum Incoming Air Pressure to the pump.* (see **Technical Data** on page 15.)

Operation

Shutdown and Care of the Pump

WARNING

To reduce the risk of serious injury whenever you are instructed to relieve pressure, always follow the **Pressure Relief Procedure** on page 7.

Never allow paint to dry in the pump and lines.

To shutdown the system

1. **Relieve the pressure.** Stop the agitator, and lubricate it.
2. If using a Graco fluid pressure regulator at the gun, reverse its regulating key and thread it into the regulator cap as far as it will go.
3. Loosen the spray gun air cap about three turns, hold a rag over the front of the air cap and fully trigger the gun. This forces paint in the gun, hose and regulator back into the circulating line. Close the fluid shutoff valves (C) at that gun station, Repeat for the other gun stations.
4. Open the bleed-type master air valve (N), and the pump air regulator (204) to restart the pump. Circulate the paint to remove all trapped air before shutting down.
5. Disconnect the gun's fluid hose from the gun and the fluid regulator. Plug the regulator outlet. Blow compressed air and compatible solvent through the hose to clean it. Clean the gun according to the instructions supplied with it. Each month remove and clean the fluid regulator.
6. If you are not using an air line lubricator, manually lubricate the motor at least once a day.
7. Circulate the fluid in the lines often enough during the shutdown to prevent the paint from drying.

NOTE: To drain the circulating lines and flush the system, see **Flushing** on page 7.

Parts Drawing

Model 230992, Series B

4:1 Ratio President Carbon Steel
55 Gallon Drum System
Includes items 1 to 4, and 6 to 12

Model 230993, Series B

2:1 Ratio Monark Carbon Steel
55 Gallon Drum System
Includes items 2 to 6, and 11

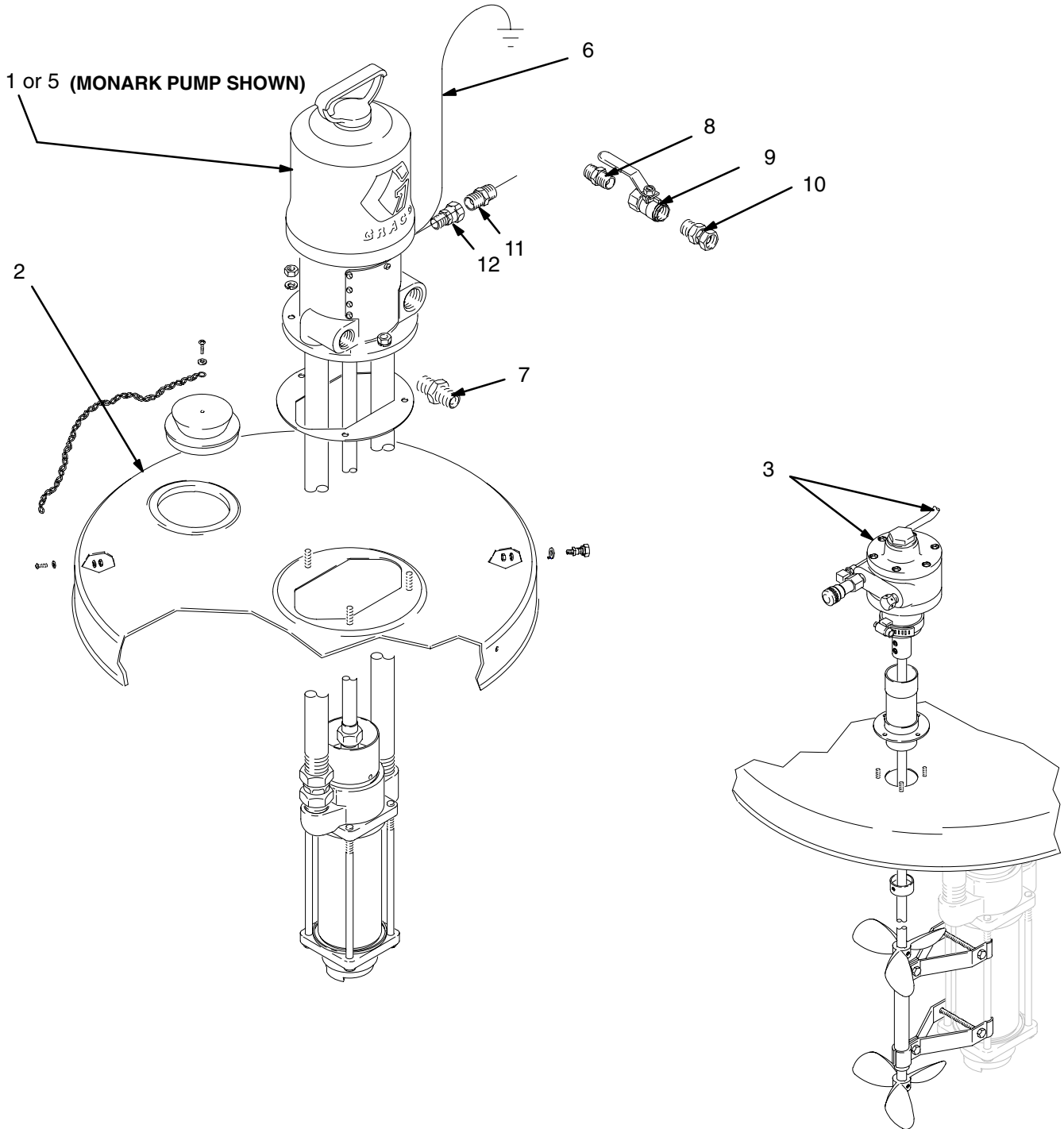

Fig. 3

c

Parts List

Model 230992, Series B

4:1 Ratio President Carbon Steel
55 Gallon Drum System
Includes items 1 to 4, and 6 to 12

Model 230993, Series B

2:1 Ratio Monark Carbon Steel
55 Gallon Drum System
Includes items 2 to 6, and 11

Ref.

Ref. No.	Part No.	Description	Qty.	Ref. No.	Part No.	Description	Qty.
1	223183	4:1 RATIO PRESIDENT PUMP; <i>See 307986 for parts.</i>	1	7	160032	NIPPLE; 3/4 npt x 2	1
2	237307	COVER, drum; <i>See 308466 for parts.</i>	1	8	158491	NIPPLE; 1/2 npt x 2	1
3	203711	AGITATOR; <i>See 306459 for parts.</i>	1	9	113331	BALL VALVE, air, bleed-type	1
5	223185	2:1 RATIO MONARK PUMP; <i>See 307985 for parts</i>	1	10	156684	UNION, adapter, swivel; 1/2" npt(m) x 1/2 npt(f)	1
6	237569	GROUND WIRE AND CLAMP	1	11	158491	FITTING, nipple(<i>used on 230992</i>)	1
				12	159239	FITTING, nipple(<i>used on 230993</i>)	1
					162505	UNION, swivel	1

Parts Drawing

Model 220575, Series B

3:1 Ratio President Stainless Steel
55 Gallon Drum System
Includes items 1-35



Remove and discard 1/2 x 3/8 npt nipple from outlet of air regulator (5a), and replace with 1/2 npt nipple (5c). Then connect air regulator assy to pump air inlet.



Agitator (3) is tilted at a 6° angle.

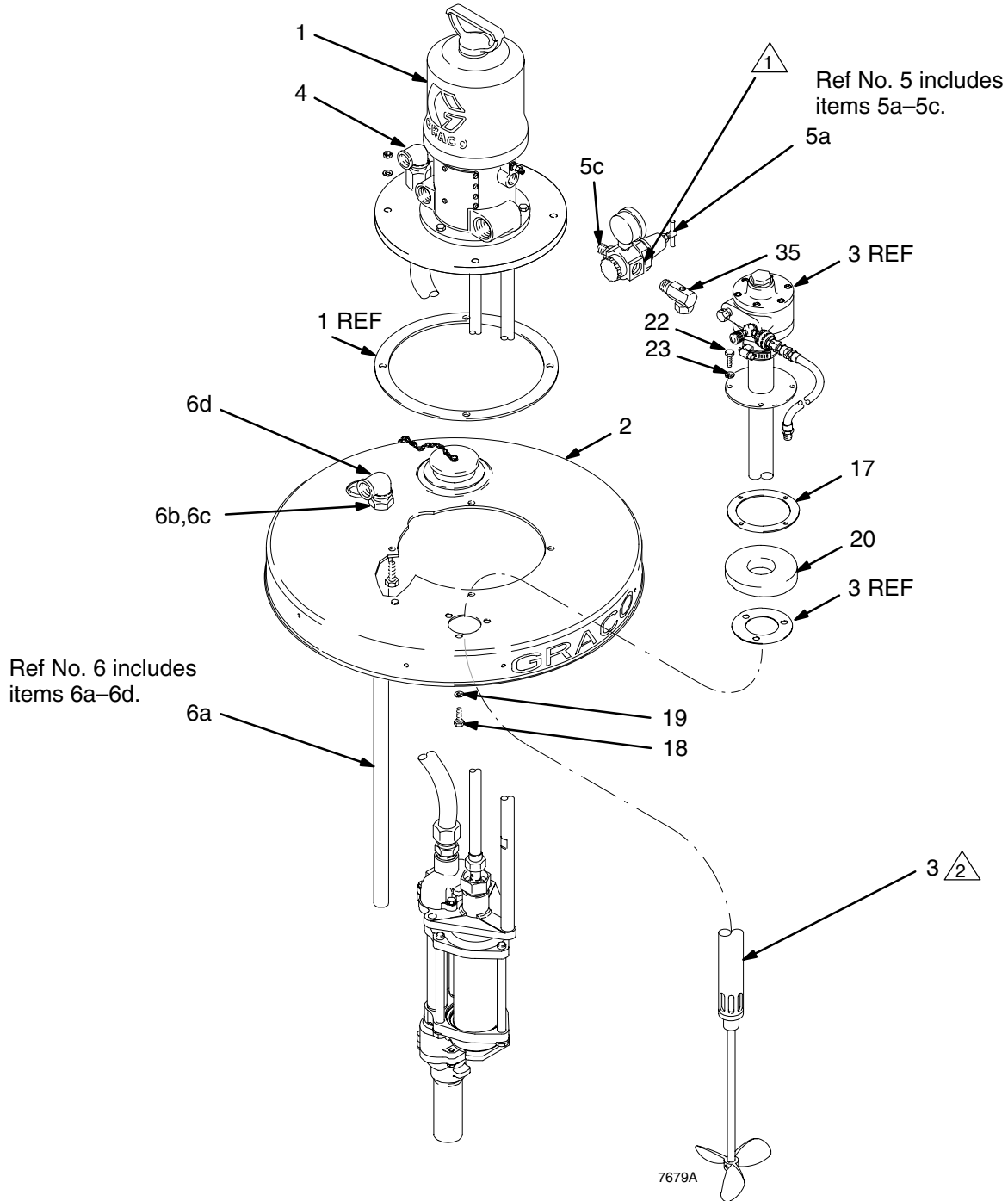

Parts List

Model 220575, Series B

3:1 Ratio President Stainless Steel
55 Gallon Drum System

Ref No.	Part No.	Description	Qty	Ref No.	Part No.	Description	Qty
				6	223319	RETURN TUBE KIT Includes items 6a-6d	1
1	220564	PUMP, President See 308793 for parts	1	6a	185393	TUBE, return; sst; 1" npt(m)	1
2	237309	COVER, drum, 55 gal. (200 liter) See 308466 for parts	1	6b	178941	NUT, hex; 1-5/8-18 unef-2b	1
3	222698	AGITATOR See 306840 for parts	1	6c	185394	ADAPTER, return; 1-5/8-18 unef-2a(m) x 1" npt(f) x 1" npt(f)	1
4	220580	RISER TUBE KIT See 307837 for parts	1	6d	108761	ELBOW, street; 1" npt (m x f)	1
5	223180	AIR REGULATOR KIT Includes items 5a-5c	1	7	185466	NIPPLE, half; 1-1/2" npt	1
5a	203716	REGULATOR, air See 308167 for parts	1	17	190192	GASKET, agitator, guide	1
5b	205418	HOSE, air; buna-N; 1/2" ID; coupled 1/2 npt (mbe); 6 ft (1.9 m) lg	1	18	112896	SCREW, cap, hex hd	4
5c	158491	NIPPLE; 1/2 npt	1	19	104123	WASHER, lock, spring	4
				20	174092	PLATE, adapter	1
				22	112894	SCREW, cap, hex hd	3
				23	112904	WASHER, lock, 5/16 in.	3
				35	100839	ELBOW, 1/8 npt (m x f)	1

Technical Data

Category	Model 220575	Model 230992	Model 230993
Ratio	3:1	4:1	2:1
Maximum fluid working pressure	500 psi (3.5 MPa, 35 bar)	400 psi (2.8 MPa, 28 bar)	200 psi (1.4 MPa, 14 bar)
Maximum air input pressure	166 psi (1.2 MPa, 11.6 bar)	100 psi (0.7 MPa, 7 bar)	100 psi (0.7 MPa, 7 bar)
Pump cycles per 1 gallon (3.8 liters)	6.3	8	11
Fluid flow at 60 cycles per minute	9.2 gpm (35.1 liters/min)	8 gpm (30.4 liters/min)	5.5 gpm (21 liters/min)
Fluid inlet size	1–1/2 npt(f)	1–1/2 npt(f)	1–1/2 npt(f)
Fluid outlet size	1 in. npt(f)	1 in. npt(f)	1 in. npt(f)
Air inlet size	1/2 npt(f)	3/8 npt(f)	3/8 npsm(f)
Weight	110 lb (50 kg)	110 lb (50 kg)	110 lb (50 kg)
Maximum pump operating temperature	180°F (82°C)	180°F (82°C)	180°F (82°C)
* Sound pressure levels (dBa) (Input air pressures at 15 cycles per minute)	73.6 dB(A) @ 40psi (0.3 MPa, 2.8 bar) 78.3 dB(A) @ 70 psi (0.5 MPa, 4.8 bar) 80.9 dB(A) @ 100 psi (0.7 MPa, 7 bar)	73.6 dB(A) @ 40 psi (0.3 MPa, 2.8 bar) 78.3 dB(A) @ 70 psi (0.5 MPa, 4.8 bar) 80.9 dB(A) @ 100 psi (0.7 MPa, 7 bar)	73.3 dB(A) @ 40 psi (0.3 MPa, 2.8 bar) 75.9 dB(A) @ 70 psi (0.5 MPa, 4.8 bar) 77.7 dB(A) @ 100 psi (0.7 MPa, 7 bar)
* Sound power levels (dBa) (Input air pressures at 15 cycles per minute)	87.4 dB(A) @ 40 psi (0.3 MPa, 2.8 bar) 92.1 dB(A) @ 70 psi (0.5 MPa, 4.8 bar) 94.6 dB(A) @ 100 psi (0.7 MPa, 7 bar)	87.4 dB(A) @ 40 psi (0.3 MPa, 2.8 bar) 92.1 dB(A) @ 70 psi (0.5 MPa, 4.8 bar) 94.6 dB(A) @ 100 psi (0.7 MPa, 7 bar)	87.0 dB(A) @ 40 psi (0.28 MPa, 2.8 bar) 89.7 dB(A) @ 70 psi (0.5 MPa, 4.8 bar) 91.4 dB(A) @ 100 psi (0.7 MPa, 7 bar)
Wetted parts	Chrome Plated Stainless Steel, Ultra-High Molecular Weight Polyethylene, Leather, PTFE	<i>Supply and Return Tubes:</i> Nickel-plated carbon steel <i>Air Motor Base:</i> Aluminum <i>Displacement Pump:</i> Refer to manual 307983	

* Tested in accordance with ISO 9614–2.