

**FETTE**  
COMPACTING



**3200*i* Tablet Press**  
**Maximum Economy of Production**  
**Double Rotary Press**  
**Single/Double Layer**



Leitz Metalworking Technology Group

## The principal advantages at a glance - 3200*i*

The innovations	Your benefits
-----------------	---------------

- High-performance rotary press, effective in practice
- Productive, precise, reliable in operation, robust →
- Exchangeable die turret → → → → → → → → → →
- Exchangeable segment turret (patent-pending) →
- Large number of stations on the turret → → → → →
- Operator terminal with 15" touch-screen → → → →
- Wide range of accessories and peripherals → → →
- Maximum security and monitoring → → → → → →
- Automatic process monitoring → → → → → → → →
- High-quality FETTE standard components → → →

- Excellent cost/benefit ratio
- Best TCO (Total Cost of Ownership) figures
- Format change over is very fast
- High yield, simplified cleaning
- Maximum profitability with large batches
- Easy to handle and operate
- Remarkable flexibility and range of applications
- 24-hour unmanned operation
- Future-proof basic equipment and software
- Conforms to GMP, GAMP and FDA



Economic aspects are always intimately related to productivity and to the equipment in use. Under circumstances in which, for example, very large to medium-sized batches of tablets are produced to meet clear specifications, the features of the press can be matched to those particular requirements without losing the benefits of mature, reliable technologies and complete flexibility.

At FETTE we have focused closely on this particular need, and developed a solution that embodies the high-quality of the standard components used in FETTE presses without compromise. The 3200*i* unites 100% economic viability with the top technology of the leader in this market sector.

Set against the context of the spectrum of modern tablet presses currently in use around the world, the 3200*i* occupies the position of the "workhorse" so convincingly that any practically relevant cost/benefit calculation comes to one clear result: FETTE 3200*i*.



Care about health is complex. Tableting technology is our contribution. FETTE COMPACTING.

## High productivity through double capacity - 3200i



- Two identically sized pre-compression and main compression stations on one turret: double capacity



### Double tablet output or 2-layer compression products

- 2 filling units
- 2 pre-compression and main compression stations
- 2 tablet outlets
- 2 Fill-O-Matics
- Up to 75 punch stations in the segment turret (patent-pending)
- Up to 79 punch stations in the die turret

### Extremely high performance figures through optimized design

- More than 1 million tablets/h
- 24-hour unmanned production
- Reduction of down-time through the use of a second exchange turret or a second segment set
- Increased yield through die table segment turret
- Increase in annual yield through use of the optimum turret in relation to the tablet diameter
- Shortening of cleaning time through easy accessibility and assembly without special tools
- Simple and flexible integration into production lines



Fully modular system, with a wide range of optional peripheral units

- 3200*i* tablet press with exchangeable die or segment (patent-pending) turret
- 15" touch-screen with clearly structured user interface
- Switch cabinet with VME bus computer
- Peripheral devices:
  - PKB stearate distributor
  - GRATEX (dust removal and de-burring of tablets)
  - VERTICAL DEDUSTER (de-dusting and vertical transport for further treatment stages)
  - CHECKMASTER 4.1 (in-process control of tablet diameter, thickness, weight and hardness)
  - WEIGHTMASTER 4.1 (alternative, for weight-checking only)
  - METALCHECK (inspection and rejection of tablets contaminated by metal)
  - LOADING CENTER (tablet filling unit)
  - HANDLING SYSTEM for turret exchange

## High flexibility with exchangeable segment turrets (patent-pending) – 3200i

Great simplification achieves powerful performance potentials

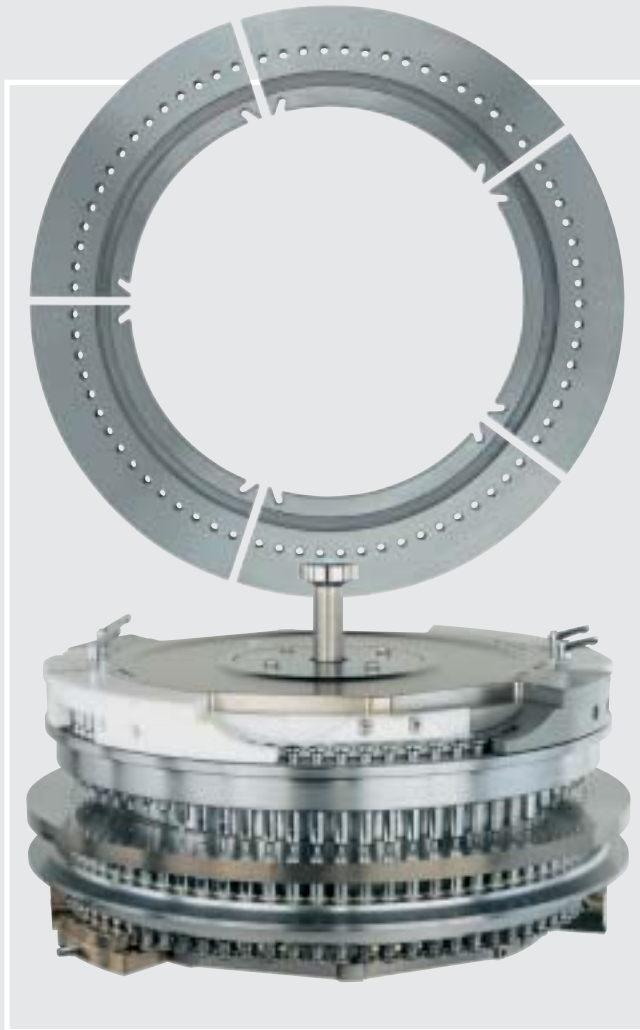

- Die table segments (patent-pending) for all current FETTE presses
- All the positive features of conventional exchangeable turrets are retained
- More stations bring up to 50% increase in yield, depending on tablet diameter
- Radically shortened fitting time through an 88% reduction in the number of parts
- Simplified cleaning without the cracks, bolts and holes of a standard die plate
- More than 50% reduction in the loss of product, depending on product properties, through smooth surfaces and the absence of gaps between the die table and the dies
- Reduced wear through optimum material properties (e. g. 63 Rockwell hardness of the segments)
- Simplified logistics through fewer parts
- Lower ejection forces bring higher tablet quality due to smooth surfaces

### Turret with patented properties

- Complete die table package is removed, including all cams and punches, patented
- Adjustment to changing production requirements in very little time
- Flexible fitting through standardized parts
- Lower punch secured by patented punch brake against falling out during exchange
- Turret optionally manufactured of stainless steel and hard-chromed
  - increased resistance to abrasion
  - increased resistance to chemicals
  - reduced surface roughness, smooth surfaces
  - fast cleaning in the washing centre



### Two-layer tablets

- 2-layer tablets in a wide range of formats
- Easy refitting from single to double layer
- Optimum layer separation

## Optimum operation with the latest hardware and software – 3200*i*

### Powerful operating panel simplifies secure operation

- 15" touch-screen for an improved overview
- Powerful Pentium industrial PC offers ideal data processing and storage
- Windows XP® operating system ensures compatibility
- Uninterruptible power supply protects against data loss
- Computer-controlled, user-friendly adjustment of the terminal height, patented
- Teleservice optional available

### Greatly simplified press operation

- Improved operation with the aid of easily understood icons and buttons
- Structured diagnostic messages for rectifying malfunctions (expert system)
- Product-specific magnitudes can be displayed in addition to parameter lists
- Help texts provide descriptions of parameters and diagnostic messages
- All production-relevant data are brought together in one view
- All batch data can be examined
- Different user levels available for security
- Full conformity with 21 CFR Part 11

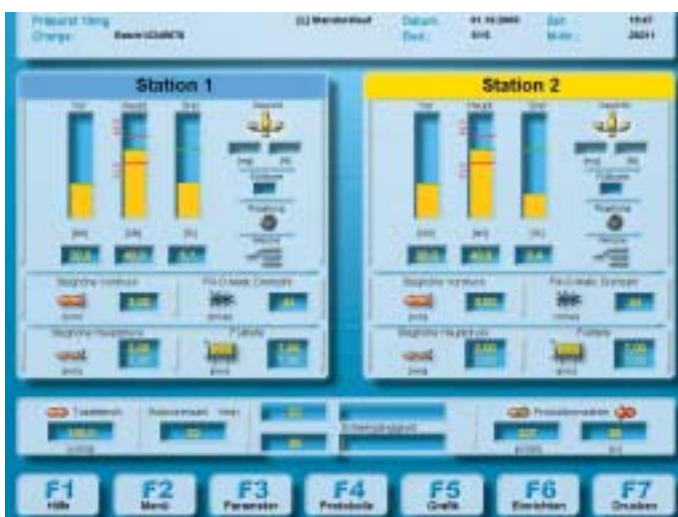

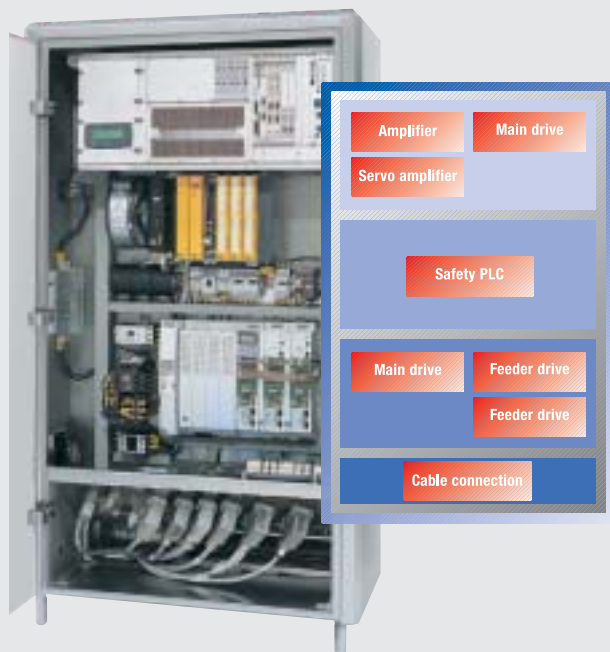
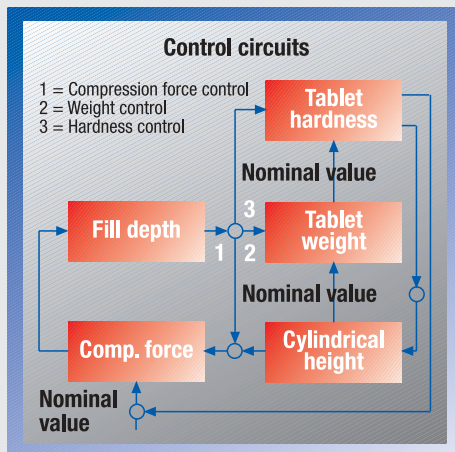

### Detailed documentation

- Any and all operator inputs and changes are recorded in a change log
- Process data documentation (production record/result record)
- Operating status documentation (diagnostic record)
- Complete overview with automatic analysis
- Batch record
- Optional version management

## Maximum security and monitoring with optimized control – 3200i

### Reliable control

- Direct control of all motor driven adjustments on the machine
- Optimal monitoring through data collection from all measuring points
- High-speed data transfer with the evaluation unit and operator interface via Ethernet TCP/IP
- Clearly structured control loops
- Highly sensitive measuring points
- Extremely stable regulation for best tablet quality
- Incorporation of production-specific data into the control process
- Precise single-tablet ejection based on compression force ensured
- Ejection force measurement for production monitoring
- Measurement of punch tightness
- Patented monitoring for punch protection
- Individual quality control, with samples drawn for specific punches
- Extraction control and monitoring for dust-free compression compartment

### Safety-oriented switch cabinet

- Flexible separation of grey and white areas
- The most up-to-date computer, real-time
- Total encapsulation of electronic components from surrounding air
- Integrated modem for remote service
- All assemblies are easily accessible
- Display of current status via LEDs
- Calibration unit allows control loop adjustments at any time
- Easy exchange of computer components
- Maximum resistance to interference and electromagnetic compatibility
- All cables plugged in at both ends
- Power and control circuitry are strictly isolated
- Unique cooling design using two separate circulation systems
- Temperature reduction through standby operation

## Divided structure with encapsulated compression compartment – 3200*i*



### Modular mechanical construction achieves functional benefits

- Optimized strength (FEM calculation) for long service life
- Maximum operating security
- Ideal working safety
- Low maintenance costs through long service intervals
- Modular design with separation into 4 sections:
  - head section
  - compression compartment
  - middle area
  - drive area

### Dust-free head section

- Plug-in, easily fitted dust extraction
- Efficient dust extraction with optional vacuum regulation
- Separate material feed essential for 2-layer tablets
- Construction of the whole machine completed by
  - sound insulation through sandwich construction and sound-insulating pillars; less than 80 dB, depending on production data
  - all cladding suspended to minimize vibration
  - reinforced window flaps, modified flap seals

### Optimally aligned pressing equipment

- Precision turret mounting
- Turret and turret shaft both frictionally engaged and form-fitting
- All compression stations of the same construction
- Adjustment of the upper compression rollers through an eccentric unit
- Lower compression rollers adjusted by servo motors
- Compression stations can be moved easily
- Pre- and main compression rollers have the same dimensions for long dwell times
- Pre- and main compression force can be up to 100 kN



#### Encapsulated compression area

- Unpainted, uncluttered compression compartment
- Ideal visibility through window flaps with no frames, double-glazed
- Very accessible from all 4 sides
- Conforms to the highest GMP standards
- Easily cleaned and easily exchanged push-in elements shorten fitting times
- Smooth surfaces for best possible cleaning
- Strict separation of drive and compression areas
- Removable, without tools, double-lip seals on the window flaps
- Filling hopper easily removed by twisting and lowering

#### The latest filling system

- Fill-O-Matic with proven three-chamber system
  - easily dismantled
  - easily cleaned
  - filling and dosage wheel easily exchanged
  - sealing segments matching the tablet diameter brings an enormous reduction in product loss
  - optionally available in washable stainless steel



#### Drive chamber optimized for fittings

- Suspended base plate with vibration insulation
- Detachable drive unit with torque support
- Stable straight bevel gear pairing with high efficiency
- Precisely tapered roller bearings



Number of Stations	79	75	73	61	75	49	49	49	55	37	45
Punch type	EU 19 BBS	EU 19 (IPT 19) Segmented turret	EU 19 (IPT 19) BB	EU 19 (IPT 19) B	EU 19 (IPT 19) Segmented turret	EU1" (IPT 1") D	EU1"-441	EU1"/EU1"-441 (IPT 1") Segmented turret	EU 35	EU 35	Segmented turret
Tablet output/h	min. max.	135,000 1,080,000	131,400 700,800	109,800 585,600	135,000 720,000	88,200 470,400	88,200 470,400	99,000 528,000	66,600 355,200	81,000 432,000	
Max. compression force	kN	100	100	100	100	100	100	100	100	100	100
Max. tablet diameter	mm	11	13	16	18	18	25	25	25	34	34
Max. filling depth	mm	18	18	18	22	22	22	22	22	26	26
Max. tablet thickness	mm	8.5	8.5	8.5	8.5	8.5	8.5	8.5	8.5	8.5 (11)	8.5 (11)
Pitch circle diameter	mm	680	680	680	680	680	680	680	680	680	680
Turret rotation speed	min <sup>-1</sup>	15-120	15-120	15-80	15-80	15-80	15-80	15-80	15-80	15-80	15-80
Die diameter	mm	22	-	24	30.16	-	38.1	-	-	52	-
Die height	mm	22.22	-	22.22	22.22	-	23.8	-	-	30	-
Punch shaft diameter	mm	19	19	19	19	19	25.35	25.35	25.35	35	35
Punch length	mm	133.6 (133.35)	133.6 (133.35)	133.6 (133.35)	133.6 (133.35)	133.6 (133.35)	133.6 (133.35)	133.6 (133.35)	133.6 (133.35)	133.6	133.6
Upper punch pen. depth	mm	2-4 (8)	2-4 (8)	2-4 (8)	2-4 (8)	2-4 (8)	2-4 (8)	2-4 (8)	2-4 (8)	2-4 (8)	2-4 (8)
Weights	Tablet press approx. 4500 kg · Operator terminal 100 kg · Electrical cabinet 350 kg										
Power supply data	Operating voltage 360-528 V, 50/60 Hz · Total fusing 50 A · Power consumption 12 kW										

\*Tools only permit up to 70 kN zu. If tools are large and filling depth is high the machine cannot be run at the highest capacity.  
 (8) at 2 layer for first layer

**Because of the technical progress we reserve the right of alteration.**

## Technical data - 3200i

## Comparative table for dies and die table segments – 3200*i*

For round tablets	For round tablets
Single dies	Die table segments
up to ø 11 mm 79 stations-EU19 dies ø 22 x 22.22 high max. filling depth 18 mm max. perf.: 1,137,600 tabl./h	up to ø 11 mm 75 stations-EU19  max. filling depth 22 mm max. perf.: 1,080,000 tabl./h
up to ø 13 mm 73 stations-EU19 dies ø 24 x 22.22 high max. filling depth 18 mm max. perform.: 700,800 tabl./h	up to ø 18 mm 75 stations-EU19  max. filling depth 22 mm max. perform.: 720,000 tabl./h
up to ø 16 mm 61 stations-EU19 dies ø 30.16 x 22.22 high max. filling depth 18 mm max. perform.: 585,600 tabl./h	up to ø 25 mm 55 stations-EU1"  max. filling depth 22 mm max. perform.: 528,000 tabl./h
up to ø 25 mm 49 stations-EU1" dies ø 38.1 x 23.8 high max. filling depth 20 (22) mm max. perform.: 470,400 tabl./h	up to ø 25 mm 55 stations-EU1"- 441  max. filling depth 22 mm max. perform.: 528,000 tabl./h
up to ø 25 mm 49 stations-EU1"-441 dies ø 38.1 x 23.8 high max. filling depth 20 (22) mm max. perform.: 470,400 tabl./h	
For oblong tablets	For oblong tablets
Single dies	Die table segments
up to ø 11 mm 79 stations-EU19 dies ø 22 x 22.22 high max. filling depth 18 mm max. perf.: 1,137,600 tabl./h	up to ø 11 mm 75 stations-EU19  max. filling depth 22 mm max. perf.: 1,080,000 tabl./h
up to ø 13 mm 73 stations-EU19 dies ø 24 x 22.22 high max. filling depth 18 mm max. perform.: 700,800 tabl./h	up to ø 18 mm 75 stations-EU19  max. filling depth 22 mm max. perform.: 720,000 tabl./h
up to ø 16 mm 61 stations-EU19 dies ø 30.16 x 22.22 high max. filling depth 18 mm max. perform.: 585,600 tabl./h	up to ø 25 mm 55 stations-EU1"  max. filling depth 22 mm max. perform.: 528,000 tabl./h
up to ø 25 mm 49 stations-EU1" dies ø 38.1 x 23.8 high max. filling depth 20 (22) mm max. perform.: 470,400 tabl./h	up to ø 25 mm 55 stations-EU1"- 441  max. filling depth 22 mm max. perform.: 528,000 tabl./h
up to ø 25 mm 49 stations-EU1"-441 dies ø 38.1 x 23.8 high max. filling depth 20 (22) mm max. perform.: 470,400 tabl./h	

## Single sided production optional – 3200*i*

### Continuous production

- If a packaging machine is attached to each station of a 3200*i*, it can happen that one of them stops, for reasons associated with the packaging machine, while the other one continues to run. The "single-sided production operation" option makes it possible to continue production at just one of the stations of the press.
- Advantage when producing single-layer tablets: if the press is fed from two containers, which will almost never become empty at exactly the same time, then when one of the containers has run out it is possible to continue production from the material remaining in the second.
- Since the 3200*i* is a symmetrical double press, the "single-sided production operation" function can also be used if components on one side fail, in order to continue operation with the other half.

