

**SEGATRICE A NASTRO  
BAND-SAW MACHINE  
BANDSÄGEMASCHINE  
SCIE A RUBAN  
SIERRA DE CINTA  
SERRA DE FITA  
BANDZAAGMACHINE**

**Art.  
NG200  
NG201**

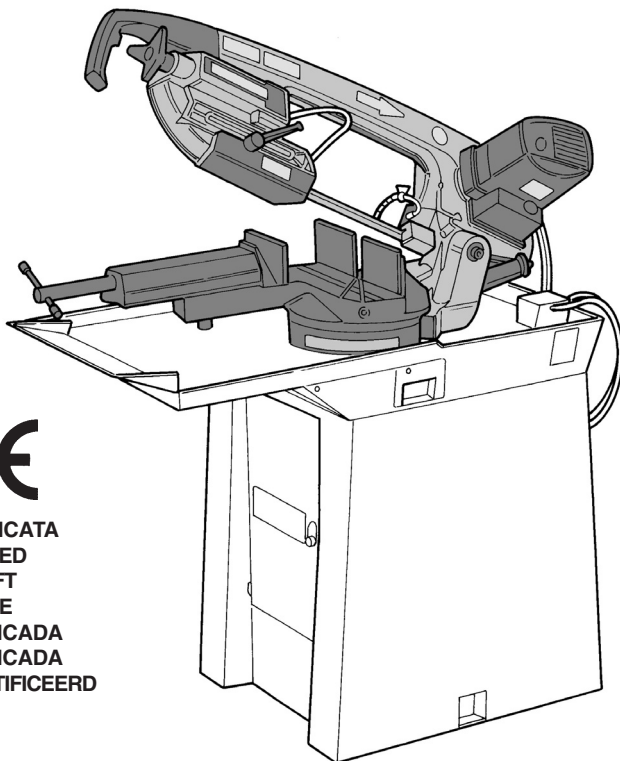

**CERTIFICATA  
CERTIFIED  
GEPRÜFT  
CERTIFIÉ  
CERTIFICADA  
CERTIFICADA  
GECERTIFICEERD**

**ISTRUZIONI PER L'USO E MANUTENZIONE  
INSTRUCTIONS FOR USE AND MAINTENANCE  
GEBRAUCHSANLEITUNGEN UND WARTUNG  
MODE D'EMPLOI ET ENTRETIEN  
INSTRUCCIONES PARA EL USO Y MANUTENCION  
INSTRUÇÕES DE UTILIZAÇÃO  
GEBRUIK- EN ONDERHOUDSAANWIJZINGEN**



[www.femi.it](http://www.femi.it)

**Packaging - Processing  
Bid on Equipment  
1-847-683-7720  
[www.bid-on-equipment.com](http://www.bid-on-equipment.com)**

DICHIARAZIONE DI CONFORMITÀ CE  
 DEL COSTRUTTORE **FEMI S.p.A.**

Via del Lavoro, 4 - 40023 Castel Guelfo (BO) - ITALIA  
 Tel. +39-0542-670160 - Fax +39-0542-670185 -  
<http://www.femi.it>

Dichiara che la: **SEGATRICE A NASTRO NG200-NG201**  
 è conforme alle disposizioni contenute nelle Direttive:  
 CEE 98/37 - 89/336 - 73/23

COMPLIANCE DECLARATION CE  
 OF THE BUILDER **FEMI S.p.A.**

Via del Lavoro, 4 - 40023 Castel Guelfo (BO) - ITALIA  
 Tel. +39-0542-670160 - Fax +39-0542-670185 -  
<http://www.femi.it>

Declare the: **BAND-SAW MACHINE NG200-NG201**  
 is in compliance with the rules contents in the Directives:  
 CEE 98/37 - 89/336 - 73/23

CE KONFORMITATS ERKLÄRUNG  
 DES HERSTELLER **FEMI S.p.A.**

Via del Lavoro, 4 - 40023 Castel Guelfo (BO) - ITALIA  
 Tel. +39-0542-670160 - Fax +39-0542-670185 -  
<http://www.femi.it>

Erklärt dass: **BANDSÄGEMASCHINE NG200-NG201**  
 ist konform mit der Direktiven:  
 CEE 98/37 - 89/336 - 73/23

DECLARATION DE CONFORMITE CE  
 DU CONSTRUCTEUR **FEMI S.p.A.**

Via del Lavoro, 4 - 40023 Castel Guelfo (BO) - ITALIA  
 Tel. +39-0542-670160 - Fax +39-0542-670185 -  
<http://www.femi.it>

Declare que la: **SCIE A RUBAN NG200-NG201**  
 est conforme aux dispositions contenues dans les Directives:  
 CEE 98/37 - 89/336 - 73/23

DECLARATION DE CONFORMIDAD CE  
 DEL CONSTRUCTOR **FEMI S.p.A.**

Via del Lavoro, 4 - 40023 Castel Guelfo (BO) - ITALIA  
 Tel. +39-0542-670160 - Fax +39-0542-670185 -  
<http://www.femi.it>

Declara que la: **SIERRA DE CINTA NG200-NG201**  
 esta conforme a las disposiciones contenide en la Directivas:  
 CEE 98/37 - 89/336 - 73/23

DECLARAÇÃO DE CONFORMIDADE CE  
 DO CONSTRUTTORE **FEMI S.p.A.**

Via del Lavoro, 4 - 40023 Castel Guelfo (BO) - ITALIA  
 Tel. +39-0542-670160 - Fax +39-0542-670185 -  
<http://www.femi.it>

Declara que a: **SERRA DE FITA NG200-NG201**  
 seguindo as regras exigidas no contendo da Directivas:  
 CEE 98/37 - 89/336 - 73/23

EG-VERKLARING VAN OVEREENSTEMMINGVAN  
 DE FABRIKANT **FEMI S.p.A.**

Via del Lavoro, 4 - 40023 Castel Guelfo (BO) - ITALIA  
 Tel. +39-0542-670160 - Fax +39-0542-670185 -  
<http://www.femi.it>

Verklaart dat: **DE BANDZAAGMACHINE NG200-NG201**  
 voldoet aan de voorschriften van de volgende Europese Richtlijnen:  
 98/37 EEG - 91/368 - 89/336 - 73/23

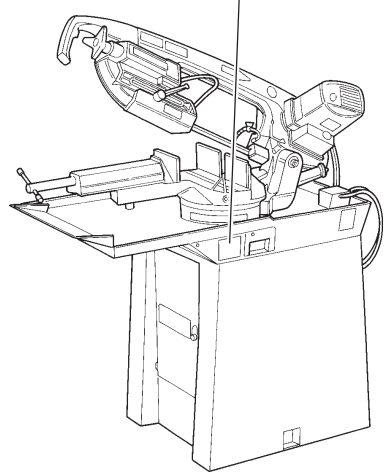

Serie - Serial - Matrikel - Matricule -  
 Matricula - Matricula - Serie

Nr. ....

- |                             |                             |                               |                               |
|-----------------------------|-----------------------------|-------------------------------|-------------------------------|
| <input type="checkbox"/> 01 | <input type="checkbox"/> 07 | <input type="checkbox"/> 2006 | <input type="checkbox"/> 2009 |
| <input type="checkbox"/> 02 | <input type="checkbox"/> 08 | <input type="checkbox"/> 2007 | <input type="checkbox"/> 2010 |
| <input type="checkbox"/> 03 | <input type="checkbox"/> 09 | <input type="checkbox"/> 2008 | <input type="checkbox"/> 2011 |
| <input type="checkbox"/> 04 | <input type="checkbox"/> 10 |                               |                               |
| <input type="checkbox"/> 05 | <input type="checkbox"/> 11 |                               |                               |
| <input type="checkbox"/> 06 | <input type="checkbox"/> 12 |                               |                               |



**FEMI S.p.A.**  
 Il Direttore Generale  
 Maurizio Casanova

ITALIANO (IT) .....	1 ÷ 8
ENGLISH (EN) .....	9 ÷ 16
DEUTSCH (DE) .....	17 ÷ 24
FRANCAIS (ES) .....	25 ÷ 32
ESPAÑOL (ES) .....	33 ÷ 40
PORTUGUÊS (PT) .....	41 ÷ 48
NEDERLANDS (NL) .....	49 ÷ 56

## INDEX

1	INTRODUCTION TO USE .....	9
2	INSTALLATION .....	10
3	ADJUSTMENT .....	12
4	USE .....	12
5	ACCESSORIES .....	14
6	MAINTENANCE .....	14
7	TROUBLESHOOTING .....	16

## 1 INTRODUCTION TO USE

Before starting work with your sawing machine, carefully read this instructions manual so that you are familiar with the machine and its uses and where it should not be used. Keep this manual in a safe place.

It is an integral part of the machine and should be used for reference in operating the machine correctly and in the proper safety conditions.

Use the machine only and exclusively for the uses specified below, as recommended in this manual. The machine should not in any way be tampered with, or forced, or used for unsuitable purposes.

### 1.1 CONVENTIONAL SYMBOLS

Never underestimate the warnings "ATTENTION - CAUTION" given in this manual.

In order to draw the user's attention and to preserve safety, hazardous operation are preceded by symbols and notes that point out the danger and explain how to behave to avoid any risk.

These symbols and notes are divided in three categories, identified by the following words:



**WARNING:** dangerous-behaviours that could cause serious injuries.



**CAUTION:** behaviours that could cause slight injuries or damages to things.



**NOTE:** the notes preceded by this symbols are technical and are aimed at making operations easier.

### 1.2 SAFETY AND RULES

The machine was designed and built according to the Community Directives in force **EEC 98/37-EEC 73/23-EEC 89/336**.

Moreover, all technical standards relating to this type of product have been complied with which provide warranty of compliance with above mentioned directives.

The enclosed CE declaration of conformity together with the CE brand on the product essentially comprise and are an integral part of the machine : both guarantee product conformity with the aforesaid safety Directives.

### 1.3 RECOMMENDED AND NOT RECOMMENDED USAGE

This machine has been designed and developed for cutting metals.

**It can cut:**

- COMMON STEELS (FE 37...)
- SPECIAL STEELS (C 40, 18NiCrMo5...)
- ALUMINIUM AND ITS ALLOYS
- BRASS
- BRONZE
- STEEL TUBING (FE 35, FE 52...)
- PROFILED SECTIONS IN SHEET METAL AND ALUMINIUM

**It is not suitable for cutting:**

- WOOD AND SIMILAR MATERIALS
- BONE AND SIMILAR MATERIALS

Consult the relative sections for cutting capacities, the speeds to use and the type of tools for use according to the material to be cut and its section. (See list of contents).

### 1.4 STANDARD SAFETY PROCEDURS

- Do not use the machine in very damp places or in the presence of inflammable liquids or gases.
- Do not use it in the open air when general weather and environmental conditions are unfavourable (eg. explosive atmospheres, during a storm or rain).
- Do not force the machine unnecessarily : excessive cutting pressure could cause rapid wear to the blade and negatively influence the performance of the machine in terms of finishes and cutting precision.
- Avoid starting of the machine by accident : do not keep the button in the handgrip pressed when you plug into the mains and check that the main switch is in position 0 (zero).
- Wear suitable clothes, without wide sleeves or articles such as scarves, chains and bracelets which could get caught in the moving parts.
- Always use personal protection devices: protective goggles as recommended by safety standards, gloves of the right size, headphones or earplugs, and hairnets if necessary.
- Use the tools recommended in this manual if you want to achieve the best performance from your sawing machine.
- Do not use the power supply cable to disconnect the plug form the outlet. Protect it from sharp edges and do not expose it to high temperatures.
- Any power cable extensions must be type approved and comply with safety standards.
- Avoid using the machine if your psycho-physical condition are precarious or upset or under the effects of alcohol or sedatives.

## 1.5 SAFETY PROCEDURS FOR FURTHER RISK



### WARNING:

**Always keep hands away from the working areas while the machine is moving: before loading or unloading the part, release the run button on the hand grip.**

- Always keep processing residues away from the cutting area.
- Always use the clamp. The parts to be cut must always be held firmly in the clamp.
- Before carrying out any maintenance work, always disconnect the power cable for the mains.
- Check that all safety guards are sound and positioned correctly before starting any work.

## 1.6 NOISE CONDITIONS

In normal conditions of use as described in this manual, this belt sawing machine determines an equivalent level of acoustic pressure:

\* Eg. cutting of a steel FE 52 tube D.160 mm thickness 10 mm, at cutting speed of 30 Mt/min., with a weighted operating cycle of 3 minutes.

Version	Leq (when operating unloaded)	Leq (during processing)*
Single phase	81,0 dB(A)	82,5 dB(A)
Three phase	79,0 dB(A)	81,2 dB(A)

The frequency root mean RMS weighed for hand-arm acceleration does not exceed 2.5m/s<sup>2</sup>.

**Measurement were obtained in compliance with UNI 7712, ISO 3740, ISO 3746 and EEC 89/392 regulation.**



**NOTE: Personal hearing protection should be used, such as headphones or earplugs.**

## 1.7 INFORMATION ABOUT ELECTROMAGNETIC COMPATIBILITY

The european regulations on safety and in particular the EEC directive 89/336 contemplate that all the equipment be equipped with shielding devices against radio interferences both from and towards the outside.

This machine is equipped with filters both on the motor and on the power supply through which the machine is safe and in compliance with above regulations.

**Tests were carried out according to EN 55011, EN 55014, EN 50082-1, IEC 1000-4-2 and IEC 1000-4-4 regulations.**

## 1.8 DESCRIPTION OF THE MACHINE (Fig. 1)

The machine consists of a machine body **D** complete with motor **F** and gear transmission. Connection to the bottom is obtained by means of a rotating support **H**.

The quick sliding chuck **O** is completely made up of cast iron while the basic tank in pressed steel for the collection of the coolant serves also as connecting base **N** with the machine bed **R** (optional).

Here is a list of the main parts with the number indicating it in the drawing.

- A** Command grip
- B** Blade tensioning device
- C** Sliding blade guide
- D** Machine body
- E** Blade
- F** Motor
- G** Control box
- H** Swivel support
- I** Shock absorber
- L** Cooling liquid pump
- M** Bar stop
- N** Tank-base
- O** Vice
- P** Clamp drive
- Q** Vice speed-slide drive
- R** Column (optional)

### SINGLE PHASE VERSION

WEIGHT = 89 Kg.

SIZE = cm 575 x 670 x H 720 in maximum overall dimensions.

PACKAGING SIZE = cm 585 x 680 x H 730

### THREE PHASE VERSION

WEIGHT = 99 Kg.

SIZE = cm 575 x 670 x H 720 in maximum overall dimensions.

PACKAGING SIZE = cm 585 x 680 x H 730

## 2 INSTALLATION

### 2.1 REMOVING THE PACKING

The machine is delivered inside a box suitable for the purpose.

Therefore, the packing must be removed completely by means of suitable tools and care must be taken in order to avoid damage to any part of the machine.

For packing disposal, please refer to 6.4 point.

### 2.2 HANDLING AND TRANSPORTION (Fig. 2)

The machine and must be moved only using suitable lifting devices.



### WARNING:

**Do not try to move or lift the machine by hand even if more people are present.**



### WARNING:

**The operations described in this manual relative to sling, transport and lifting by means of a fork lift or hoist must be carried out only by skilled and qualified personnel (EEC/98/37).**

To move the machine while it is still inside the packing, use a fork lift by inserting the two forks in the rooms provided under the bearing board

Move the machine carefully and avoid sudden movements which could unbalance the load and make it drop.

To remove the machine from the plate after packing removal, loosen the fixing screws but keep them should the machine be transported for long stretches.

To transport the machine after freeing it from the plate, secure it with resistant chains, ropes or braces, by passing them through the slits **A** provided in the basic tank.

Then the machine must be lifted using a hoist of adequate capacity or through another means suitable for this purpose.



**WARNING:**  
Do not lift the machine by the body **D** (Fig. 1).



**WARNING:**  
Before lifting the machine, check that the body is lowered and secured to the rest of the structure by means of ropes or other claming means.

## 2.3 ELECTRICAL CONNECTIONS (Fig. 3)

Check that the mains to which the machine is connected is earthed in accordance with current safety regulations and that the power point is in good condition.

Connect a plug in compliance with safety rules to the end of the mains cable of the machine, checking that the yellow/green protective conductor is fitted into the relative terminal marked.

**(ONLY FOR THREE-PHASE VERSION:** check for the correct polarity of the motor through the blade which must rotate in the direction shown by the arrow present on the machine body. If this is not the case, invert two of the three cables of the plug.

Mount electric panel **A** into its seat on the pivoting support, and finally secure it by tightening the supplied fixing screws. Remember that there should be a magnetothermic protective device fitted upstream of the mains to protect all the conductors from short circuits and overloads. This protective device should be selected according to the electrical features of the machine stated on the motor.

The motor of your sawing machine is equipped with a protective heat circuit breaker which interrupts the power supply when the temperature of the coils rises too high. When the power supply is interrupted, wait for normal reset.

## SINGLE PHASE VERSION (Fig. 4)

In case of power failure in mains, while you wait for power to be restored there is no danger hazard may arise : in fact, the electronic speed variator is also equipped with a reset function which prevents the machine from re-starting automatically.

To start the machine, press the start push button **A** on the handgrip twice.

## THREE PHASE VERSION (Fig. 3-4)

In case of voltage failure in the system, you can wait for the connection to be restored without danger of hazardous conditions. In fact, the electric panel is equipped with a reset function which prevents the machine from restarting automatically.

To restart the machine, press the button **C** (Fig. 4) and then push button **A** (Fig. 4) on the handgrip.



**WARNING:**  
Never change the overload cutout setting to avoid overloads which could damage the motor circuits and other mechanical members.

Your sawing machine is equipped with a motor protection obtained through a amperometric limiter which prevents the motor from absorbing a current higher than the set one, expressed by the maximum prescribed value of absorption. If the limiter triggers while the machine is operating, slightly diminish the cutting pressure. This enables to safeguard the life and performance of the blade as well as to always obtain a clean and precise cut.

## 2.4 POSITION/WORK STATION (Fig. 5)

Position the machine by moving it as described in paragraph 2.2 on to a sufficiently level bench, in such a way that the coolant can reflow in the collecting tank during the cutting operations.

Taking the ergonomic criteria into consideration, the ideal height shall be that which enables you to position the table between 90 and 95 centimetres from the floor (see Fig. 2).

Now, cut the strap which holds the body lowered and remove the wooden cap which protects the machine while in transit.



**CAUTION:**  
Read attentively the two labels on the handgrip before starting any operation.



**CAUTION:**  
Make sure that the machine is placed in a working area with suitable environmental conditions and lighting. The general conditions of the working environment are of fundamental importance for accident prevention.

Now lift the machine body and fit the eyelet of the suspension tie rod **A** into its housing on the pin **B**, then place the elastic ring **C** into the relative groove on the same pin to stop the tie rod coming out.

## 3 ADJUSTING

### 3.1 TENSION OF THE BLADE (Fig. 4)

Turn the handwheel clockwise **B** till the green indicator lights **C** up.

 **WARNING:**  
The tensioning device is equipped with a safety microswitch which prevents the machine from operating till the blade is tensioned correctly.

### 3.2 BAR STOP (Fig. 6)

Use the bar stop supplied if you have to do several cuts on pieces of the same length.

In this way you do not have to repeat the same measurement each time.

Before adjust the bar stop, be sure the main switch **B** (Fig. 7) is in 0 position.

Screw rod **A** into the hole of the vice and fasten it with nut **B** Slacken the handwheel **C** and place the stop **D** at the correct distance from the blade. Tighten handwheel **C** again.

### 3.3 CUTTING ANGLE (Fig. 7)

The machine can effect cuts ranging from 0° to 60°.

To unlock the body rotation, release the handle **A** on the rotating support.

Rotate the machine body to the left up to the stop which is set to 60° by the manufacturer.

To have the stop set to 45°, loosen the handwheel **E**, pull the bracket **D** till the end of stroke corresponding to the end of the slot of the bracket and re-lock the handwheel **E**. Now, when the machine body is turned to the left, the stop is automatically at 45°.

To restore the stop at 60°, proceed as above described and re-position the bracket **D** to its original position.

For all other inclinations, match the mark **C** of the rotating support and the corresponding position on the plate **B**.

### 3.4 CUTTING SPEED (Fig. 8-3)

#### SINGLE PHASE VERSION (Fig. 8)

Your sawing machine is equipped with CESC (Constant Electronic Speed Control), which allows gradual and continuous variation of the cutting speed, adapting it to the type and dimension of the material to be cut (see cutting table).

To select the most suitable speed, use the speed control knob **A** to increase or decrease the speed as you require.

#### THREE-PHASE VERSION (Fig. 3)

Use the speed variator **B** to select the most suitable cutting speed according to the type and section of the material to be cut (see CUTTING TABLE).

### 3.5 SLIDING BLADE GUIDE (Fig. 3)

The sliding blade guide **D** with integrated protection fitted on your sawing machine is used to perform the cut while guiding the necessary part of the blade and fully protecting the part not used in the cutting process. Slacken the knob **E** and slide the blade guide **D** so as to move it closer to or further from the part to be cut, as shown in the figure.

 **WARNING:**  
If this adjustment is not done, the part of the blade not used in the cutting process will be exposed and this will create an extra risk of contact, besides altering the quality of the cut.

### 3.6 BEARINGS BLADE GUIDE (Fig. 9)

The blade guides **A** on the outside of the sawing machine are eccentric and adjustable so as to simplify blade replacement and to keep it guided as its best.

They must always touch the blade slightly, so that they rotate when the blade passes, but must not be completely locked.

In order to approach or remove the eccentric blade guides, gently turn the head of the screws **B** using a 10 mm. wrench key.

## 4 USE

### 4.1 BLADE COOLING (Fig. 11)

Your sawing machine is equipped with an automatic blade cooling system controlled by a motor pump **A** positioned inside the tank.

Before operating the machine, prepare **12 litres** of a 10% oil-water emulsion by pouring directly the necessary oil into the water with a temperature not lower than 10 degrees. Agitate the mixture thoroughly and pour it in the pump tank **B**.

Do not operate the machine without coolant to avoid damage to the blade.

Use the oil specified for the preparation of the coolants (see OIL TABLE)

 **CAUTION:**  
Always check that the lubrication jet is aimed towards the blade and that its cock is not opened too much before you put the machine in operation.

#### OIL TABLE

BRAND	OIL TYPE
AGIP	OXALIS
CASTROL	SUPER
CHEVRON	EP
ESSO	KUTWELL
MOBIL	SOLVAC
SHELL	DROMUS
TOTAL	LACTUGA
IP	UTENS

## 4.2 WORKING



### WARNING:

**Before any cutting operation, check that all safety guards are sound and correctly positioned.**

### SINGLE-PHASE VERSION (Fig. 8)

Switch the main switch **B** to position **1** so that it lights up and the machine is ready.

### THREE-PHASE VERSION (Fig. 3)

Press button **C** of main switch **B**.

Select the desired speed by means of the speed variator provided.

Once you have completed all the procedures and operations described so far, you may start the working processes.

To perform the cut, move to the front of the machine and grip the handgrip with your right hand.



### WARNING:

**Keep your left hand away from the cutting area and on no account try to reach it when cutting is in process.**

Using the index finger of your right hand, press the run button **A** (Fig. 4) and gradually lower the machine body until it comes lightly into contact with the part to be cut. Now begin to apply gradual pressure on the part and complete the cut.

Always release button **A** (Fig. 4) between one cutting operation and another, while you are positioning the part. Do not try to block it or alter its functional characteristics in any way.

If the machine suddenly stops after numerous consecutive cuts, do not be alarmed.

The heat protector device of the motor has been activated, breaking the power supply when the temperature of the coils reaches the threshold limit defined by the insulation class, to prevent damage to the motor.

In this case, release the button **A** (Fig. 4) and wait for automatic reset which usually takes place after a few minutes.

## 4.3 RUNNING IN THE BLADE

To obtain the best performance, the bi-metal blades fitted on your sawing machine must be run in for a short period. For this reason the first two or three cuts should be done where possible on a solid piece D.70-80 mm, using a very slight pressure on the blade, and gradually increasing pressure in subsequent cuts.

To gauge the correct pressure in normal operating conditions defined by this manual (see cutting table), consider for example that the first cut on solid steel (eg. C40) D.80 mm should be done in about 5 minutes.

After running-in, the same piece may easily be cut in about 2 minutes. If the running-in process is done correctly, the finish and precision of the cut will be of better quality and the blade will last longer.

## 4.4 REPLACING THE BLADE

When you perform this operation, always wear protective gloves to avoid contact with the teeth of the blade.

- make sure that the main switch **B** (Fig. 3)/(Fig. 8) is in position **0**;
- turn the handwheel **B** (Fig. 4) counterclockwise until the tensioning device indicator turns off;
- loosen handles **D** (Fig. 4) to move the sawblade guides **E** (Fig. 4) as far as they go;
- loosen handwheels **A** (Fig. 12) and remove the safety guard by lifting it from its seat **B** (Fig. 12);

**Removing the safety casing activates the safety microswitch which automatically disables the motor.**

- fit the new blade first between the guides, then onto the wheels;
  - tighten the blade again.
- Check that the back of the blade goes to rest on the bearing inside the upper part of the machine body **A** (Fig. 10): if it does not, slacken the blade slightly and move it back into the right position.
- fit the protective casing.

At this point, activate button **A** (Fig. 4) with small impulses so that the blade positions itself correctly on the pulleys.

## 4.5 USING THE VICE (Fig. 13)

The chuck of the saw is of the quick sliding type so that the slider easily and rapidly approaches the pieces to be locked.

To lock the piece to be cut in the chuck:

- place yourself in front of the machine;
- release the lever **A** towards the piece to be cut by unlocking vice part **B**;
- position the slider at a few millimetres from the piece to be cut;
- move the **A** towards the piece and lock it;
- turn lever **C** clockwise so as to definitely lock the piece between the jaws.

If more pieces of the same bar are to be cut, you only need to unlock and then re-lock the chuck by means of lever **C**.

If you need, instead, to change the bar, turn the lever **C** counterclockwise to unlock the chuck and then pull lever **A** towards you so that the slider moves away from the piece.

## 4.6 CORRECT POSITIONING OF THE PIECE IN THE CLAMP (Fig. 13)

The pieces to be cut should be fitted directly between the jaws **D** without adding other objects.



### WARNING:

**Never hold the pieces to be cut in your hand.**

When the pieces to be cut are profiled sections, flat pieces or special shapes, refer to the examples shown in the figures.

If the thickness of the profiled section is to be very thin, an outline should be fitted which copies the profile inside the profiled section itself to stop it being crushed between the jaws.

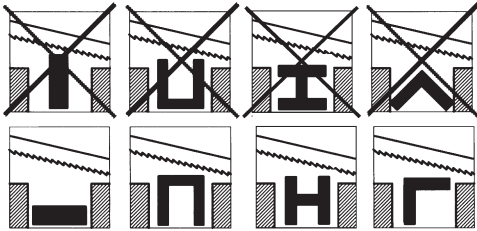

**4.7 CUTTING CAPACITY**

The table below specifies the cutting capacity at 90, 45 and 60 degrees which may be obtained in normal conditions of use described in this manual and without placing any other object between the jaws of the clamp.

Section	Angle	Cutting capacity (mm)
	90 gradi	170
		170 x 170
		190 x 130
	45 gradi	110
		110 x 110
		150 x 110
	60 gradi	75
		75 x 75
		100 x 75

**4.8 CUTTING TABLE**

Section	Material	S (mm)	Z/1"	Mt/Min MF TF	Nr MF TF
	Common and special steel	< 50	6/10	50 60	4 2
		> 50	4/6	40 30	3 1
	Aluminium and alloy Brass-bronze	< 50	6/10	60 60	6 2
		> 50	4/6	60 60	6 2
	Stainless steel	< 50	6/10	30 30	1 1
		> 50	4/6	30 30	1 1
	Iron tubing	< 3	14	60 60	6 2
		> 3 < 30	6/10	50 60	4 2
		> 30	4/6	40 30	3 1
	Profiles	< 3	14	60 60	6 2
		> 3 < 30	6/10	50 60	4 2
		> 30	4/6	40 30	3 1

**5 ACCESSORIES**

**5.1 CHOISE OF BLADE**

Your sawing machine is equipped with a bi-metal blade measuring 2140x19x0.9 mm with variable toothing 6/10 teeth per inch, for use in the majority of cuts possible with this machine.

For special requirements (see cutting table), for example, for cutting large solid sections or profiled sections or corner pieces of small thickness, there are also blades available with 4/6 toothing or 14 teeth per inch.

- MATERIAL: ..... M42 (steel for springs + steel HSS)
- EXTENSION: ..... mm 2140
- HEIGHT: ..... mm 19
- THICKNESS: ..... mm 0,9
- TOOTHING: ..... standard 6/10
- ..... optional 4/6 - 14

**6 MAINTENANCE**

**6.1 ROUTINE MAINTENANCE**

The interventions of routine maintenance which can also be carried out by unskilled personnel are described in this paragraph and in the previous ones.

**! WARNING:**  
Before any maintenance work, disconnect the machine plug from the mains.

**! WARNING:**  
During the maintenance works, always wear protective gears (protective goggles and gloves of adequate size).

**AFTER EVERY USE**

- If need be, remove any chip in the cutting area and on the sawblade guides. We recommend the use of a brush or an exhaust fan.

**! WARNING:**  
The use of compressed air is absolutely prohibited !!!

- Check for the correct height of suction of the pump from the tank and make sure that the coolant comes out from both dispensers placed on the sawblade guides.

## EVERY WEEK

- Lubricate the slides of the sliding blade guide and the swivel support and the nut screw of the chuck.
- Remove the chips from the area of the coolant collecting filter.
- Clean the sawblade guide plates with a brush.
- Check that all machine safety guards are not damaged and that the start push button works properly.
- If the saw is not used for a long period of time, clean and store it in a place free from humidity. In this case, it is advisable to loosen the blade in order not to keep it uselessly tensioned.

## 6.2 REPLACEMENT OF THE COOLANT

The refrigerating emulsion must be replaced every 500 hours.

- Remove the plug from the wall outlet to disconnect the machine.
- Empty the pump tank by removing cap **C** (Fig. 11) and remove the chips inside of it, if any.
- Prepare the new emulsion, as specified at item 4.1 and pour it inside the tank. Make sure that the emulsion is properly disposed of.
- For emulsion disposal, please refer to item 6.4.

## 6.3 AFTER-SALES SERVICE

In case of repair under guarantee, the receipt/purchase invoice must be presented together with the machine.

The absence of this document will invalidate the guarantee applied to the machine.

Should the presence of skilled personnel be necessary for extraordinary maintenance work or in case the repair is effected both under guarantee or after it, please always contact an authorised centre or the dealer where you purchased the machine, if an authorised centre is not present in your region.

When you contact the after-sales service or the dealer, always advise the purchase date of the machine and its serial number engraved on the CE.

When ordering spare parts, information about the machine's model, the serial number as well as the part code listed in the spare parts table must always be given to the After-sales Service.

## 6.4 DISPOSAL OF THE MACHINE, PACKING AND EMULSION

At the end of the machine life, if the machine must be scraped, contact an authorised waste disposal centre in order to comply with the Standards for hygiene and environment safeguard.

The packing must be disposed of according to the ruling standards by delivering it to authorised people for the collection, disposal or reclaim.

The recovered refrigerating emulsion can not be disposed of in the environment since according to the governing laws it is classified as special waste and as such must be delivered to people that are authorised to effect the collection, stocking and disposal.

Please contact the ASSOCIATION OF USED OILS near to you.



2002/96/EC

EN

## 7 TROUBLESHOOTING

PROBLEMS	PROBLEMS CAUSES	SOLUTIONS SUGGESTED
<b>The motor does not work.</b>	Defective motor, power cable or plug.	Specialized personnel should check the machine; do not attempt to repair the motor by yourself.
	Blown electric panel fuses.	Check fuse integrity and replace, if necessary.
	No voltage in the mains system.	Check for voltage in the mains system.
	The overload cutout has tripped.	Release the run button and wait a few minutes for the overload cutout to reset.
<b>Overload cutout tripped.</b>	Motor overheating.	Check that motor air intakes are clear.
	Motor overload caused by excessive cutting pressure.	Perform the cut on the piece at the correct pressure.
	Motor breakdown.	Specialized personnel should check the machine; do not attempt to repair the machine by yourself.
<b>Inaccurate cutting angle at 90° - 45° - 60°.</b>	The setting of the D retainers (point 3.3) is inaccurate.	Set the retainers by unloosening the fastening screws and re-positioning them.
<b>Inaccurate cut squaring.</b>	Excessive cutting pressure (on pipes and section bars).	Decrease cutting pressure.
	Incorrect blade toothing in relation to the piece to cut. Incorrect adjustment of the eccentric and sliding blade-guides.	Check the cutting parameters (blade toothing, cutting speed) in the cuts table (point 4.8).
	Incorrect cutting speed in relation to the piece to cut.	Check blade-guide adjustment (points 3.5 and 3.6).
	The piece is wrongly positioned in the vice.	Check piece positioning and clamping in the vice (point 4.6).
<b>Cut finish is coarse or corrugated.</b>	The blade is worn or its toothing is not right for the thickness of the piece being cut.	Check the cutting parameters (blade toothing, cutting speed) in the cuts table (point 4.8).
	Excessive cutting pressure.	Decrease cutting pressure.
<b>The blade tends to protrude from the guides.</b>	Incorrect eccentric blade-guide adjustment.	Check eccentric blade-guide adjustment (point 3.6).

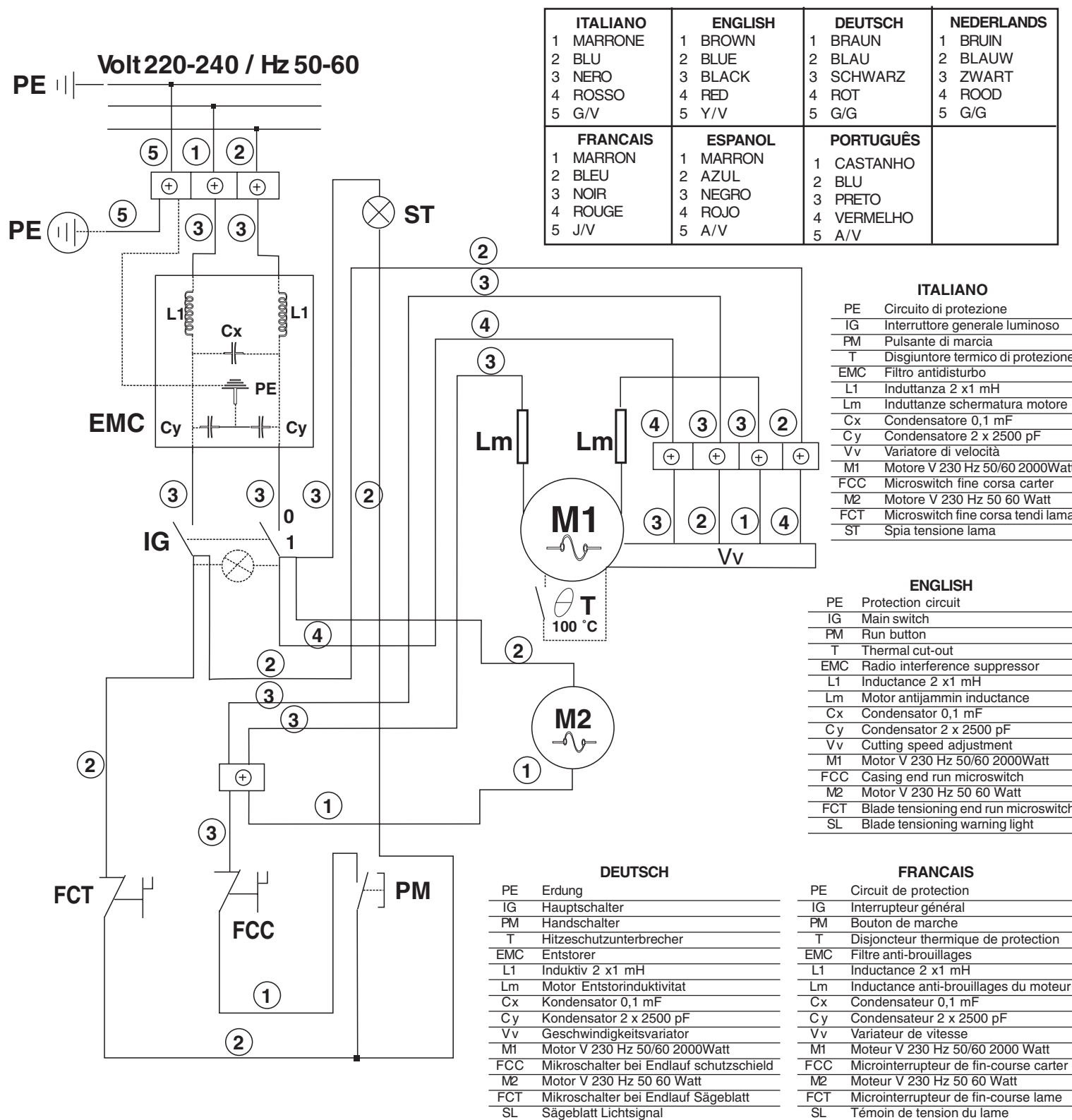

# SEGATRICE A NASTRO / BAND-SAW MACHINE BANDSÄGE-MASCHINE / SCIE A RUBAN SIERRA DE CINTA / SERRA DE FITA / BANDZAAGMACHINE

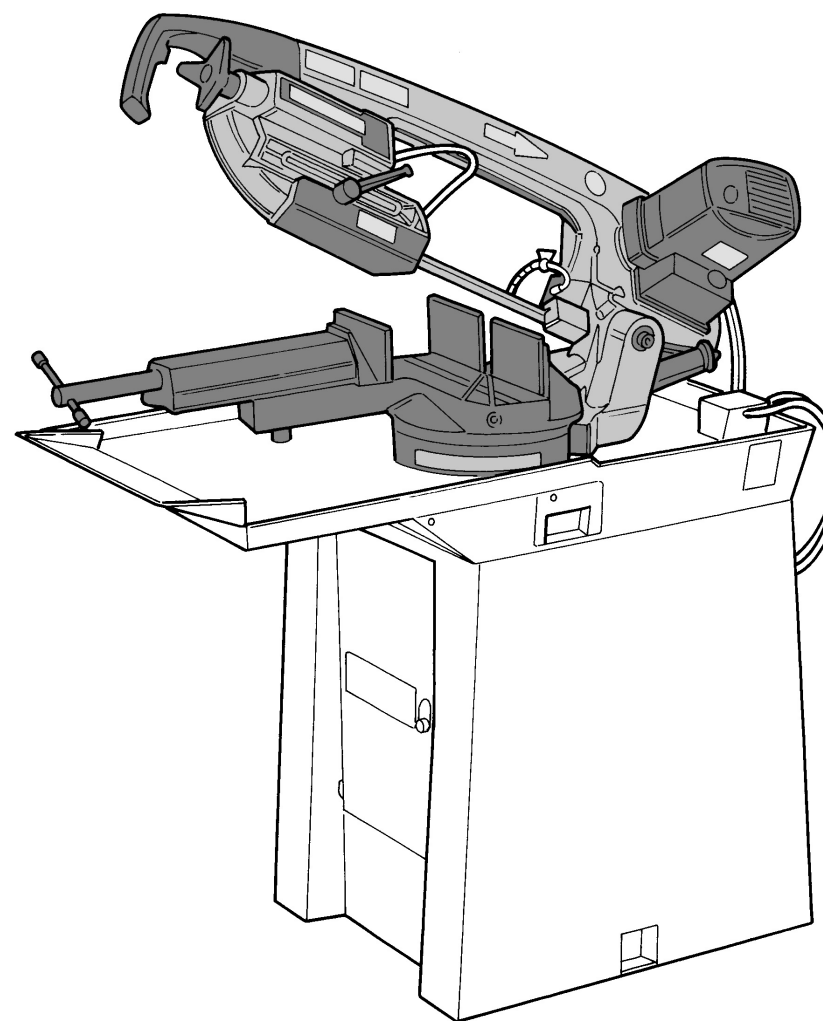

Art.  
NG200  
NG201



CERTIFICATA  
CERTIFIED  
GEPRÜFT  
CERTIFIE  
CERTIFICADA  
CERTIFICADA  
GECERTIFICEERD

ALLEGATO: ISTRUZIONI PER L'USO E MANUTENZIONE  
ENCLOSURE: INSTRUCTIONS FOR USE AND MAINTENANCE  
ANLAGEN: GEBRAUCHSANLEITUNGEN UND WARTUNG  
ANNEXE: MODE D'EMPLOI ET ENTRETIEN  
ANEXO: INSTRUCCIONES PARA EL USO Y MANUTENCION  
ANEXO: INSTRUÇÕES DE UTILIZAÇÃO  
BIJLAGE: GEBRUIK- EN ONDERHOUDSAANWIJZINGEN



www.femi.it

SCHEMA ELETTRICO: VERSIONE TRIFASE-WIRING DIAGRAM: THREE PHASE VERSION-ELEKTRISCHER SCHALTPLAN: DREHSTROMVERSION-SCHEMA ELECTRIQUE: VERSION TRIPHASEE-ESQUEMA ELECTRICO: VERSION TRIFÁSICA-ESQUEMA ELÉCTRICO: VERSÃO TRIFÁSICA-BEDRADINGSCHEMA: UITVOERING MET DRIE-FASENMOTOR

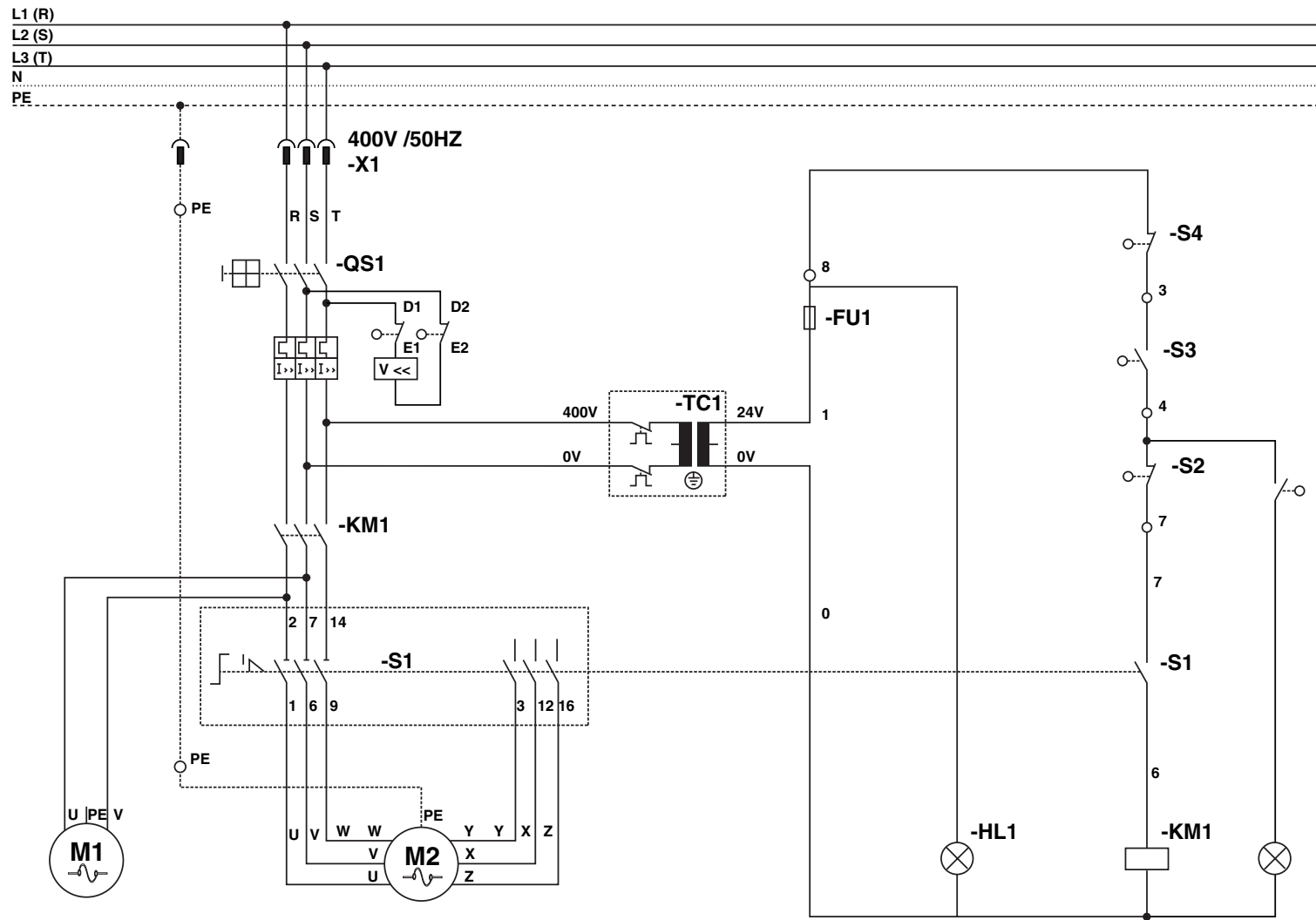

ITALIANO	
QS1	Interruttore generale magnetotermico
KM1	Contattore
TC1	Trasformatore
S1	Commutatore 2 velocità
S2	Fin de carrera carter
S3	Interruttore partenza motore
S4	Fincorsa tensionatore lama
HL1	Lampada linea
M1	Motore pompa
M2	Motore macchina

ENGLISH	
QS1	Main cutoff switch
KM1	Contact maker
TC1	Transformer
S1	2 speed changeover switch
S2	Case limit switch
S3	Motor start switch
S4	Blade tensioner limit switch
HL1	Line led
M1	Pump Motor
M2	Machine motor

DEUTSCH	
QS1	Haupt-Wärmeschutzschalter
KM1	Kontaktgeber
TC1	Trafo
S1	Zweiwegschalter
S2	Endschalter Abdeckung
S3	Motor-Startschalter
S4	Endschalter Blatt-Spannungs vorrichtung
HL1	Lampe Leitung
M1	Pumpenmotor
M2	Maschinemotor

FRANCAIS	
QS1	Interrupteur general magneto-thermique
KM1	Disjoncteur
TC1	Transformateur
S1	Commutateur a 2 vitesses
S2	Fin de course carter
S3	Interrupteur depart moteur
S4	Fin de course du dispositif de mise en tension de la lame
HL1	Lampe ligne
M1	Moteur de la pompe
M2	Moteur de la machine

ESPAÑOL	
QS1	Interruptor general termomagnético
KM1	Contactador
TC1	Transformador
S1	Commutador de 2 velocidades
S2	Fin de carrera carter
S3	Interruptor arranque motor
S4	Fin de carrera tensador hoja
HL1	Lámpara de línea
M1	Motor de la bomba
M2	Motor de la maquina

PORTUGUÊS	
QS1	Interruptor geral magnetotérmico
KM1	Contactador
TC1	Transformador
S1	Comutador a 2 velocidades
S2	Fim de percurso do carter
S3	Interruptor de arranque do motor
S4	Fim de percurso do esticador da lâmina
HL1	Lâmpada de linha
M1	Motore do pompa
M2	Motore do maquina

NEDERLANDS	
QS1	Magnetothermische hoofdschakelaar
KM1	Contactgever
TC1	Transformator
S1	Snelheidsschakelaar 2 snelheden
S2	Eindaanslag carter
S3	Uitschakelaar motor
S4	Eindschakelaar zaagspanner
HL1	Lijnlamp
M1	Pompmotor
M2	Machinemotor

NEDERLANDS	
QS1	Magnetothermische hoofdschakelaar
KM1	Contactgever
TC1	Transformator
S1	Snelheidsschakelaar 2 snelheden
S2	Eindaanslag carter
S3	Uitschakelaar motor
S4	Eindschakelaar zaagspanner
HL1	Lijnlamp
M1	Pompmotor
M2	Machinemotor

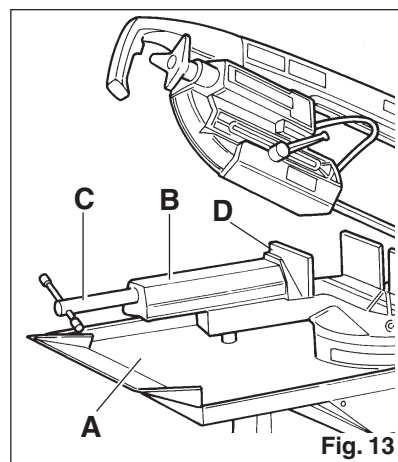
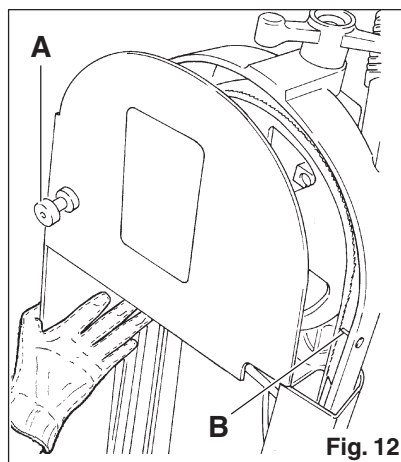
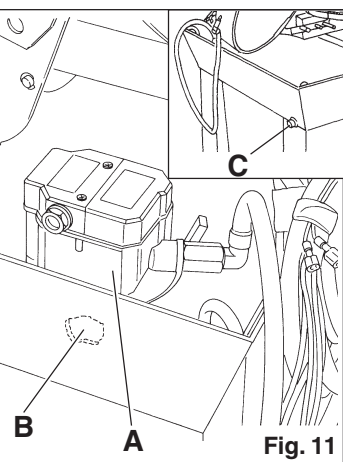
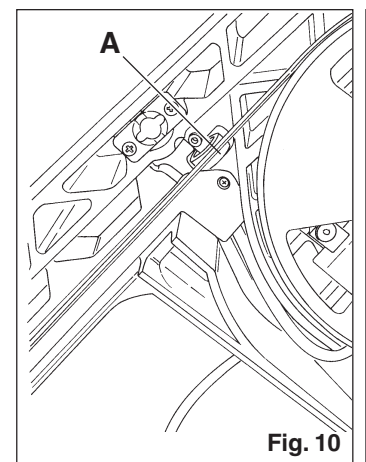
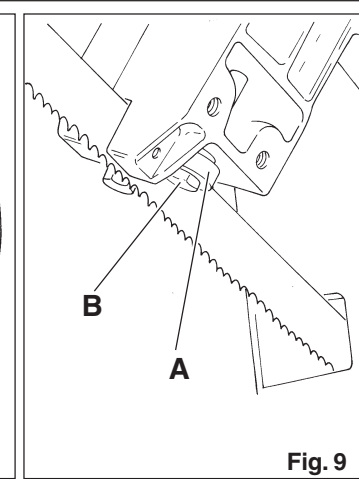
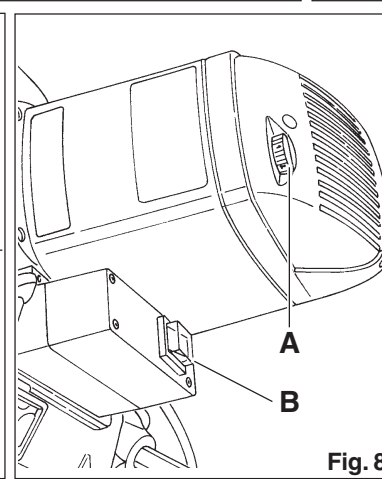
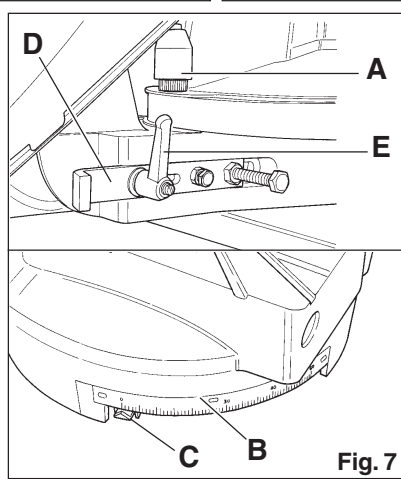
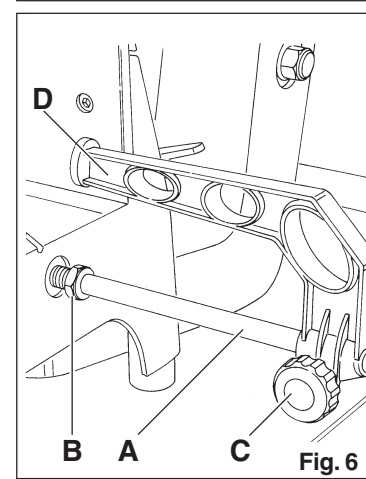
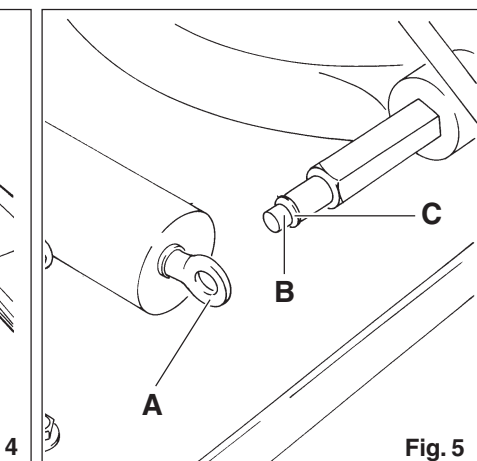
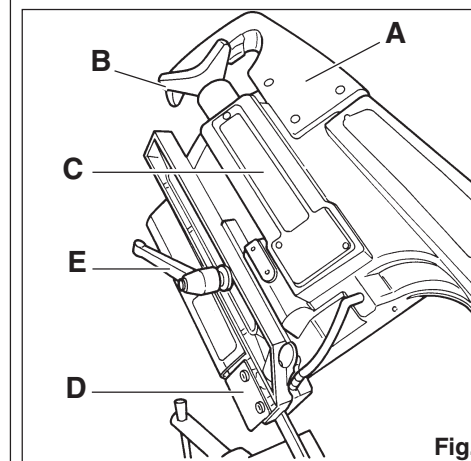
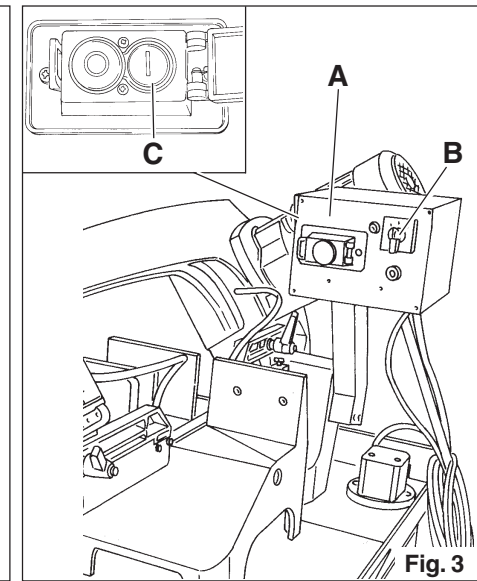
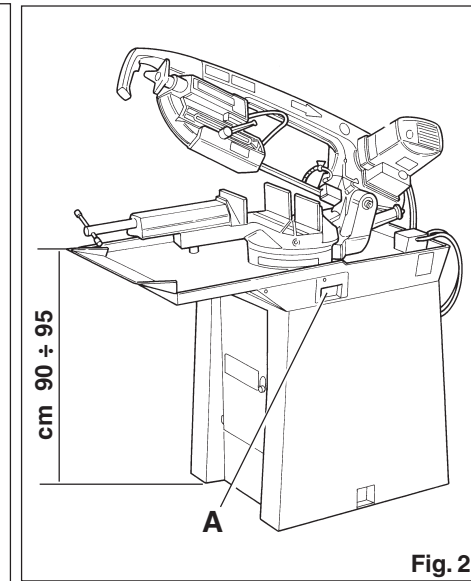
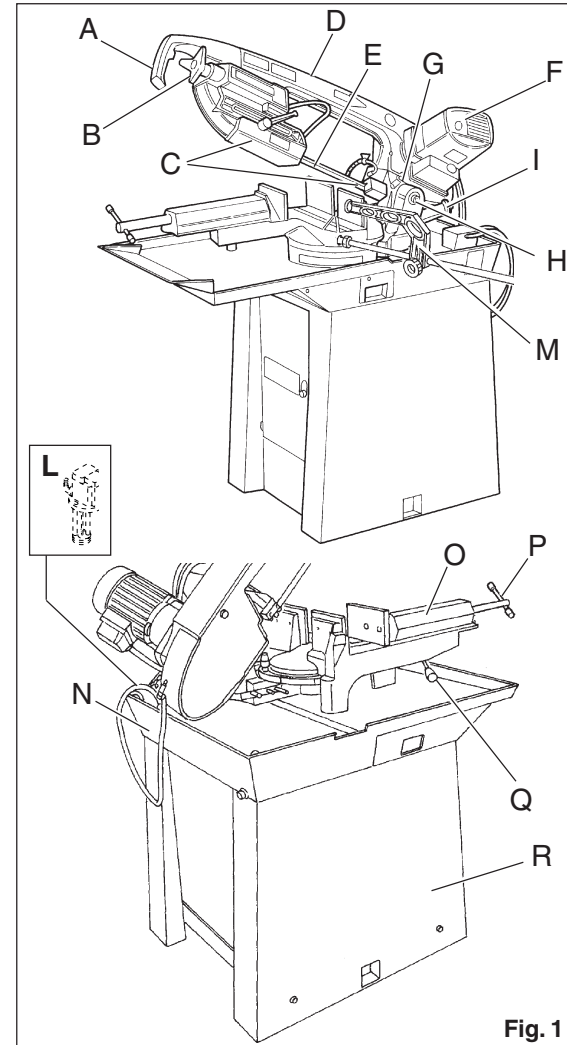

NR. 1 - NG200-201

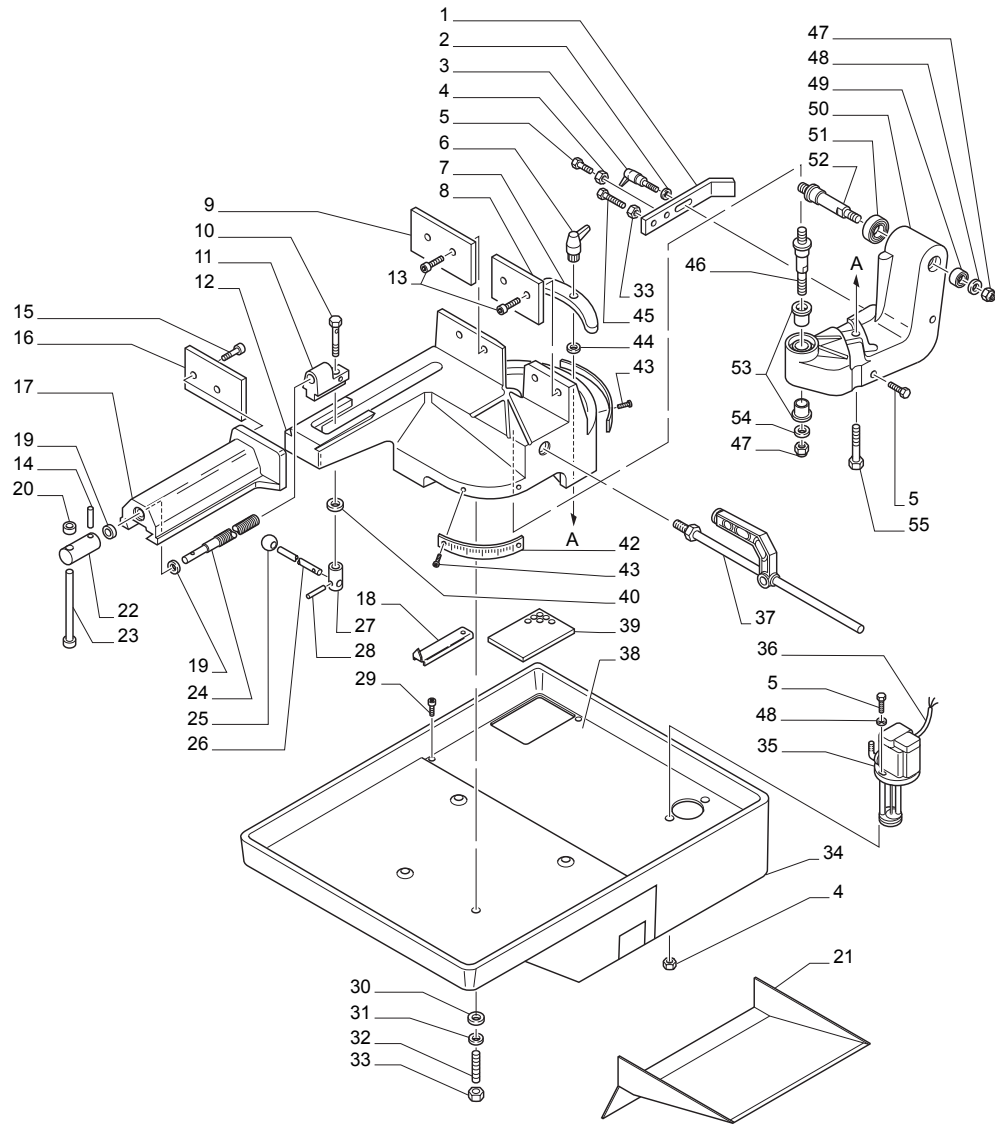

POS.	COD./KOD.	NOTE/MERKE/ NOTES/NOTA/NOTAS	POS.	COD./KOD.	NOTE/MERKE/ NOTES/NOTA/NOTAS
1	5.13.07.96		30	5.12.40.33	
2	UNI 6592 Ø 6,5x18		31	0.12.07.08	
3	0.14.70.07		32	UNI 5923 M8x35	
4	UNI5588 M6		33	UNI 5588 M8	
5	UNI 5737 M6x20		34	5.13.37.03	
6	0.14.70.12		35	7.11.35.24	
7	5.18.25.32		36	5.87.10.38	
8	5.15.25.95		37	7.13.05.36	
9	5.15.25.94		38	5.18.25.33	
10	UNI 5931 M14x70		39	5.18.25.34	
11	5.13.08.64		40	5.12.40.56	
12	5.13.79.63		41	5.13.08.01	
13	UNI 5931 M8 X 30		42	5.40.19.35	
14	0.15.26.30		43	0.40.29.05	
15	UNI 5931 M8x30		44	0.12.40.32	
16	5.15.26.11		45	UNI 5737 M8x50	
17	5.13.08.63		46	5.17.10.38	
18	5.15.95.17		47	0.10.17.16	
19	UNI 6592 Ø14		48	UNI 6592 Ø6	
20	0.14.00.59		49	0.60.62.03	
21	5.18.17.62		50	5.13.79.64	
22	5.17.10.40		51	0.60.63.06	
23	5.14.20.23		52	5.17.10.39	
24	5.10.03.23		53	5.06.30.36	
25	0.14.00.73		54	UNI 6592 Ø16	
26	5.14.20.57		55	UNI 5737 M12x50	
27	5.17.10.35				
28	0.15.24.24		56	UNI 5933 M8x25	
29	UNI 6954 P8x9,5		57	5.12.40.60	
			58	0.60.62.04	

NR. 2 - NG200-201

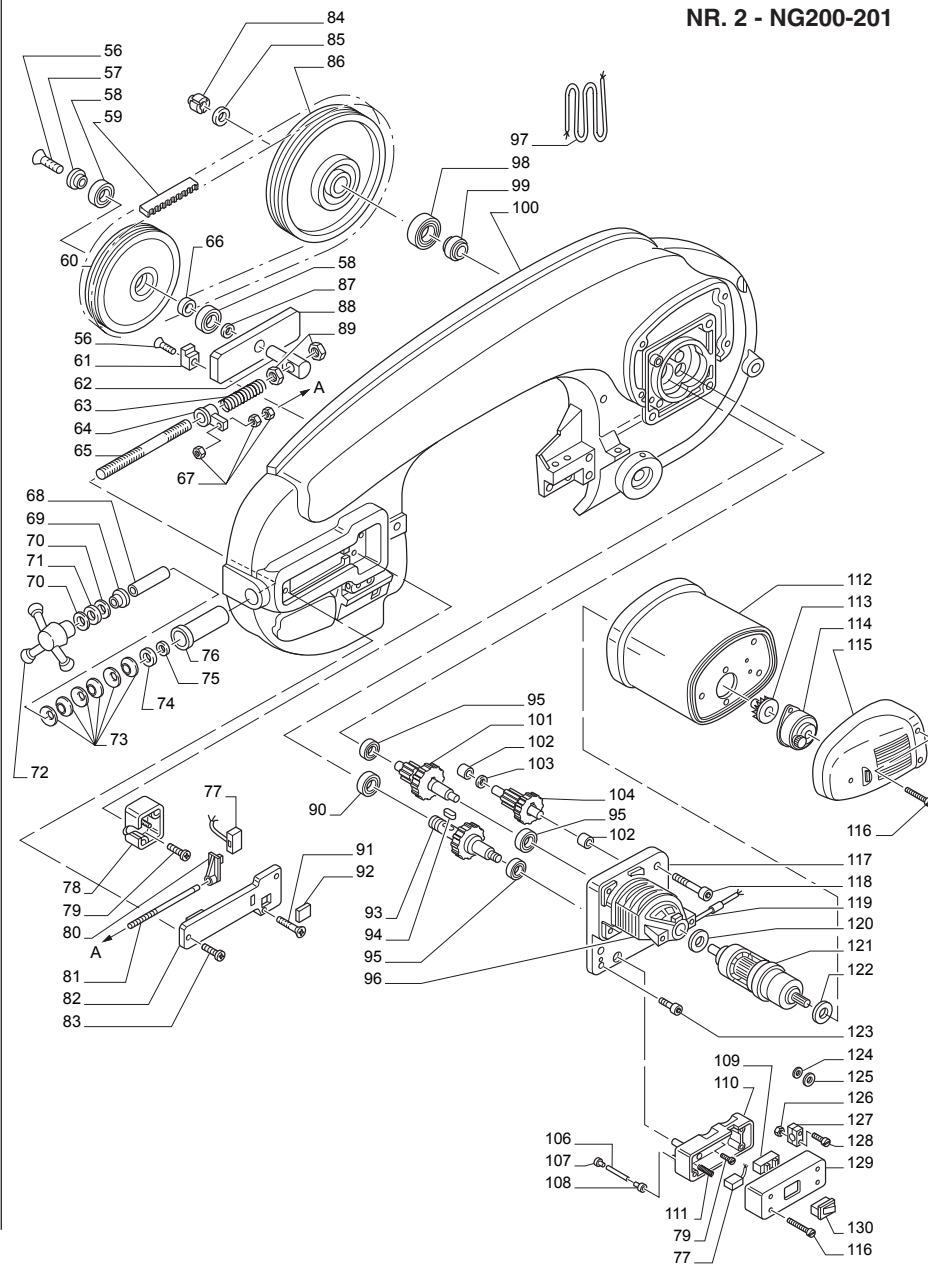

POS.	COD./KOD.	NOTE/MERKE/ NOTES/NOTA/NOTAS	POS.	COD./KOD.	NOTE/MERKE/ NOTES/NOTA/NOTAS
59	3.27.73.58		88	5.13.07.95	
60	0.21.42.24		89	UNI 5589 M12	
61	5.13.07.46		90	0.60.62.04	
62	5.00.15.62		91	UNI 6954 P7x16	
63	5.08.10.07		92	0.89.40.07	
64	5.14.20.58		93	7.21.30.06	
65	5.10.05.05		94	0.15.01.39	
66	5.12.06.61		95	0.58.62.00	
67	UNI 5588 M4		96	5.02.41.18	
68	5.12.20.17		97	5.87.10.36	
69	5.12.40.30		98	0.60.60.07	
70	0.06.40.02		99	5.12.40.54	
71	0.71.15.28		100	5.04.28.10	
72	0.14.00.99		101	7.21.30.05	
73	0.08.02.60		102	0.73.12.12	
74	UNI 6592 Ø16		103	0.12.40.26	
75	5.22.20.09		104	7.21.30.04	
76	5.06.60.16		105	5.85.00.06	
77	0.80.11.01		106	1.18.03.04	
78	5.18.28.42		107	0.16.85.13	
79	DIN 7500 M5x10		108	0.16.85.15	
80	5.14.30.05		109	0.81.60.04	
81	5.14.20.59		110	5.18.28.23	
82	5.18.25.23		111	5.08.10.08	
83	UNI 7687 M4x10		112	5.18.28.43	
84	0.10.61.20		113	5.85.01.37	
85	UNI 6592 Ø20		114	7.82.01.07	
86	5.21.40.26		115	5.18.25.25	
87	0.15.51.49		116	UNI 7687 M5x35	

NR. 3 - NG200-201

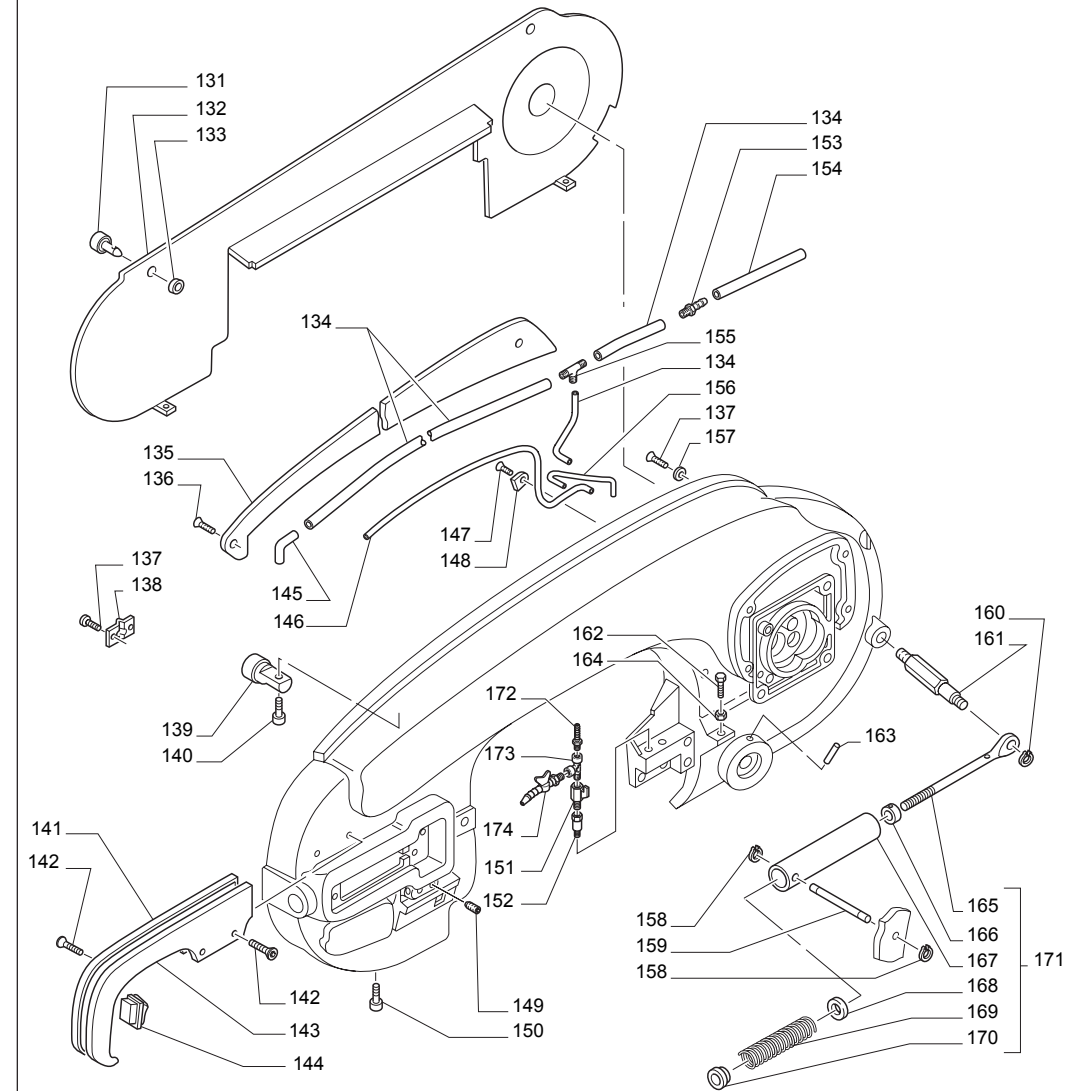

POS.	COD./KOD.	NOTE/MERKE/ NOTES/NOTA/NOTAS	POS.	COD./KOD.	NOTE/MERKE/ NOTES/NOTA/NOTAS
117	7.80.16.46		146	5.87.10.60	
118	UNI 5931 M6x40		147	DIN 7500 M5x15	
119	0.81.60.05		148	5.15.41.03	
120	5.06.10.41		149	UNI 5927 M6x10	
121	7.01.31.45		150	5.17.10.37	
122	5.06.10.38		151	0.24.03.09	
123	UNI 5931 M6x20		152	0.24.13.02	
124	0.18.10.18		153	0.24.14.43	
125	0.18.10.21		154	1.85.58.05	
126	UNI 5588 M4		155	0.24.13.66	
127	5.15.45.01		156	5.14.20.30	
128	UNI 7687 M4 x20		157	UNI6592 Ø5	
129	5.18.25.04		158	UNI7434 Ø8	
130	0.80.23.19		159	5.15.15.06	
			160	UNI 7434 Ø8	
131	0.14.00.77		161	5.17.10.41	
132	5.18.16.48		162	UNI 5927 M10x45	
133	0.12.33.15		163	UNI 5927 M8x10	
134	1.85.58.03		164	UNI 5588 M10	
135	5.18.16.88		165	5.17.30.27	
136	DIN 7500 M5x10		166	5.15.51.55	
137	DIN 7500 M5x16		167	5.04.00.10	
138	5.15.25.96		168	5.12.40.61	
139	7.13.05.67		169	5.08.01.24	
140	UNI 5931 M5x16		170	5.12.40.38	
141	5.05.01.37		171	7.13.05.72	
142	0.42.07.66		172	0.24.14.42	
143	5.05.01.36		173	0.24.13.03	
144	0.80.23.24		174	7.24.03.04	
145	0.24.13.67				

NR. 4 - NG200-201

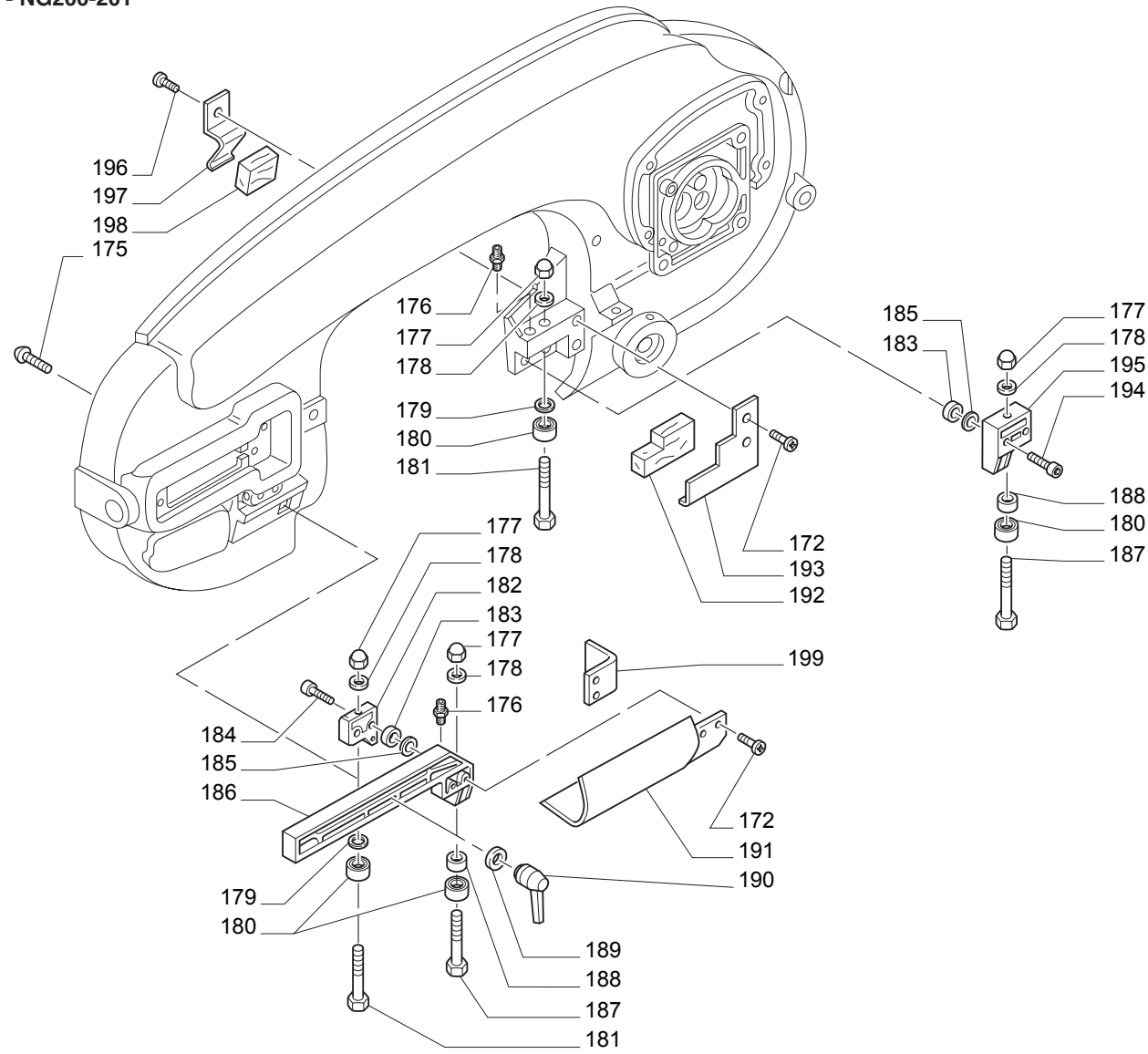

POS.	COD./KOD.NOTE/MERKE/NOTES/NOTA/NOTAS
175	UNI 5732 M10x40
176	0.24.14.42
177	UNI 5721 M6
178	UNI 1751 Ø6
179	5.12.06.38
180	0.60.06.07
181	5.10.00.70
182	5.13.07.47
183	0.60.06.26
184	UNI 5931 M6x25
185	0.12.40.27
186	5.13.07.42
187	5.10.00.69
188	0.06.30.25
189	0.12.40.29
190	0.14.70.02
191	5.18.16.83
192	5.18.10.18
193	5.18.16.28
194	UNI 5931 M8x30
195	5.13.07.47
196	UNI 7987 M6x10
197	5.18.16.27
198	5.18.10.17
199	5.18.17.63

NR. 5 - NG200-201

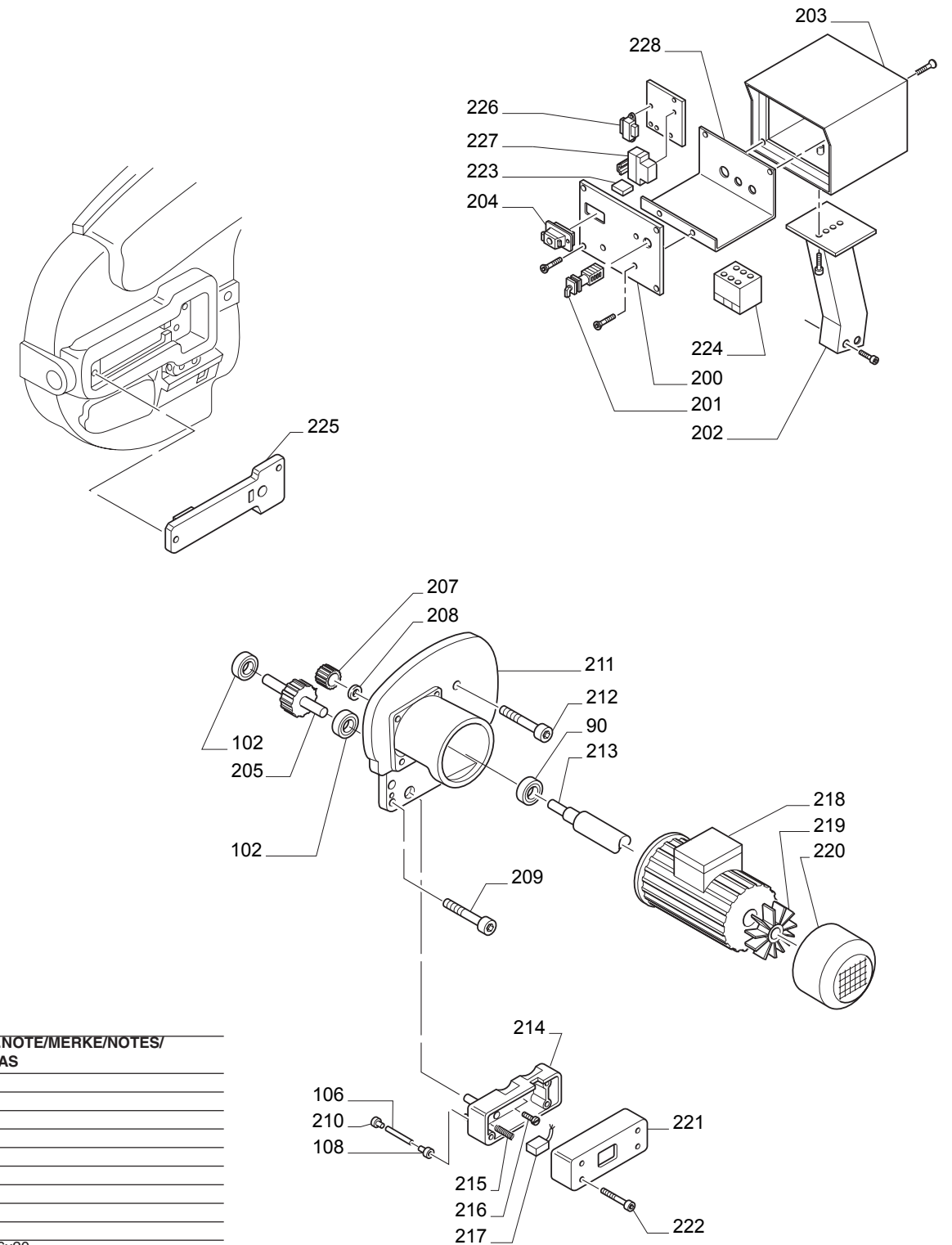

POS.	COD./KOD.NOTE/MERKE/NOTES/NOTA/NOTAS
200	5.40.15.65
201	0.82.00.10
202	5.13.78.83
203	5.07.00.01
204	0.80.60.07
205	7.21.30.12
206	0.58.62.00
207	5.09.01.19
208	0.12.01.12
209	UNI5931 M6x20
210	0.16.86.13
211	5.18.25.45
212	UNI 5931 M6x40
213	7.01.36.26
214	5.18.28.66
215	5.08.10.08
216	DIN 7500 M5x10
217	0.80.11.01
218	7.80.10.76
219	0.11.20.14
220	5.18.28.49
221	5.18.25.46
222	UNI 6954 P8x32
223	0.80.60.06
224	0.81.10.01
225	7.82.01.10
226	0.84.02.02
227	0.81.00.03
228	5.13.78.84