

ELLIOTT AUTOMATIC CASE ERECTOR

The Elliott Automatic Case Erector Bottom Taper or Hot Melt Gluer is a compact machine for erecting and sealing a wide range of case sizes in a limited space. It is portable and quickly adjustable for changing case sizes. The erector is built within a single unitized machine frame. Squared cases are assured by case transfer system.

Model 93FIL Automatic Case Erector Bottom Case Taper or Hot Melt Gluer

Case Speeds up to 15 CPM

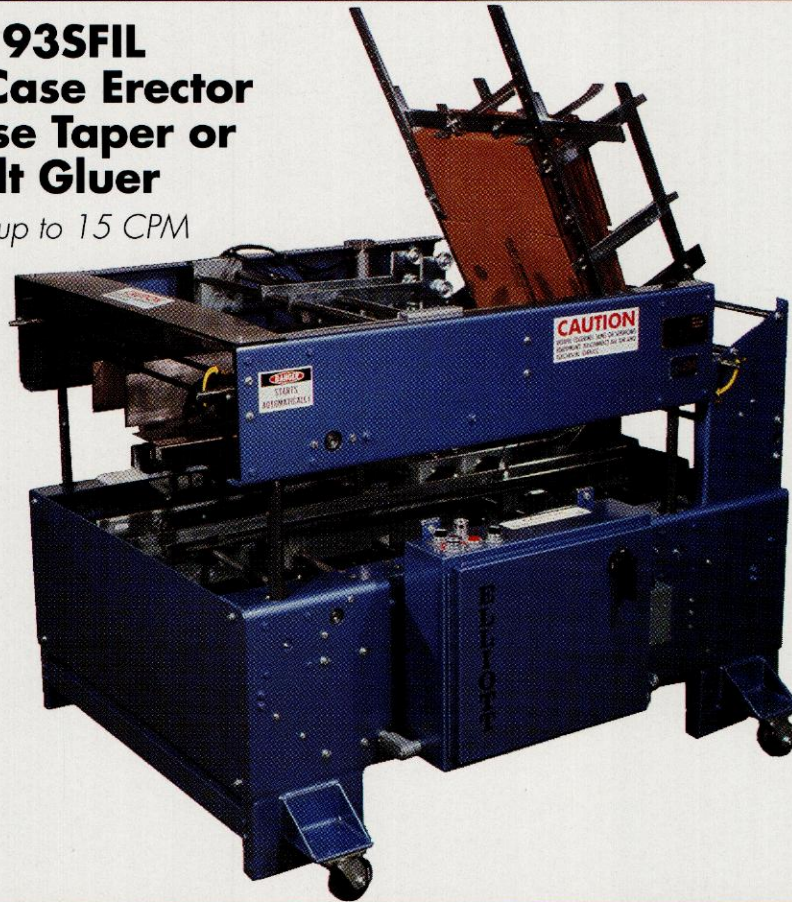

■ Comes complete with:

- Right-Hand Quick Change Crank Adjustments
- 460/230 volt, 3 phase, 60 hz
- Engraved Legend Plates for Switch Circuitry
- NEMA 12 Electrical
- Safety Guards
- Motors, Drives, Electrical and Pneumatic Controls
- Identification & Function Plates

■ Machine Dimensions:

- 5'-6" Long
- 48" Wide
- 24" Discharge Height

■ Case Range:

- Length 6" to 18"
- Width 6" to 16"
- Height 6" to 16"

Elliott

**MANUFACTURING
COMPANY, INC.**

DESIGN ENGINEERS AND MANUFACTURERS OF FOOD PROCESSING AND PACKAGING MACHINERY

2664 S. Cherry
Fresno, CA 93706
Ph 209/231-6231
Fax 209/231-6232

P.O. Box 11277
Fresno, CA 93772

**Packaging - Processing
Bid on Equipment**

1-847-683-7720
www.bid-on-equipment.com

90 SERIES SMALL FRAME IL CASE OPENER & FORMER

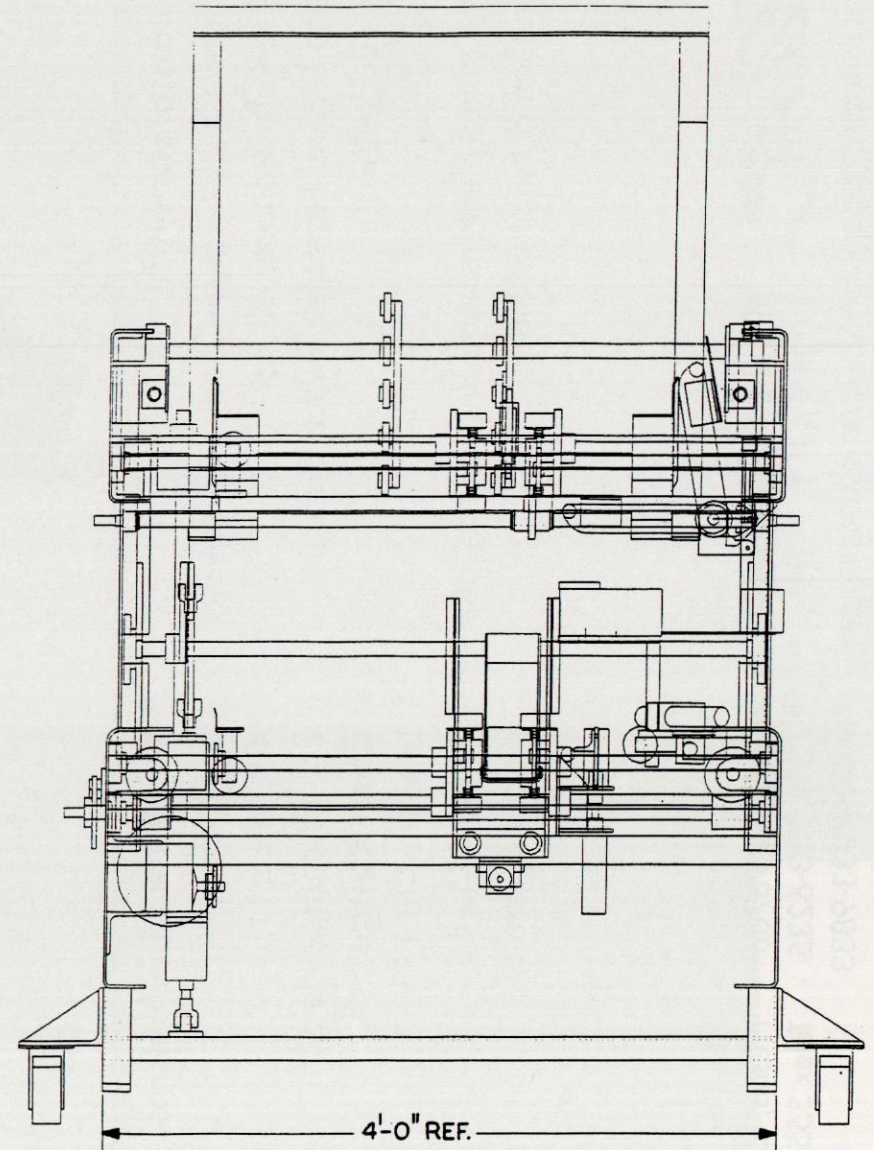
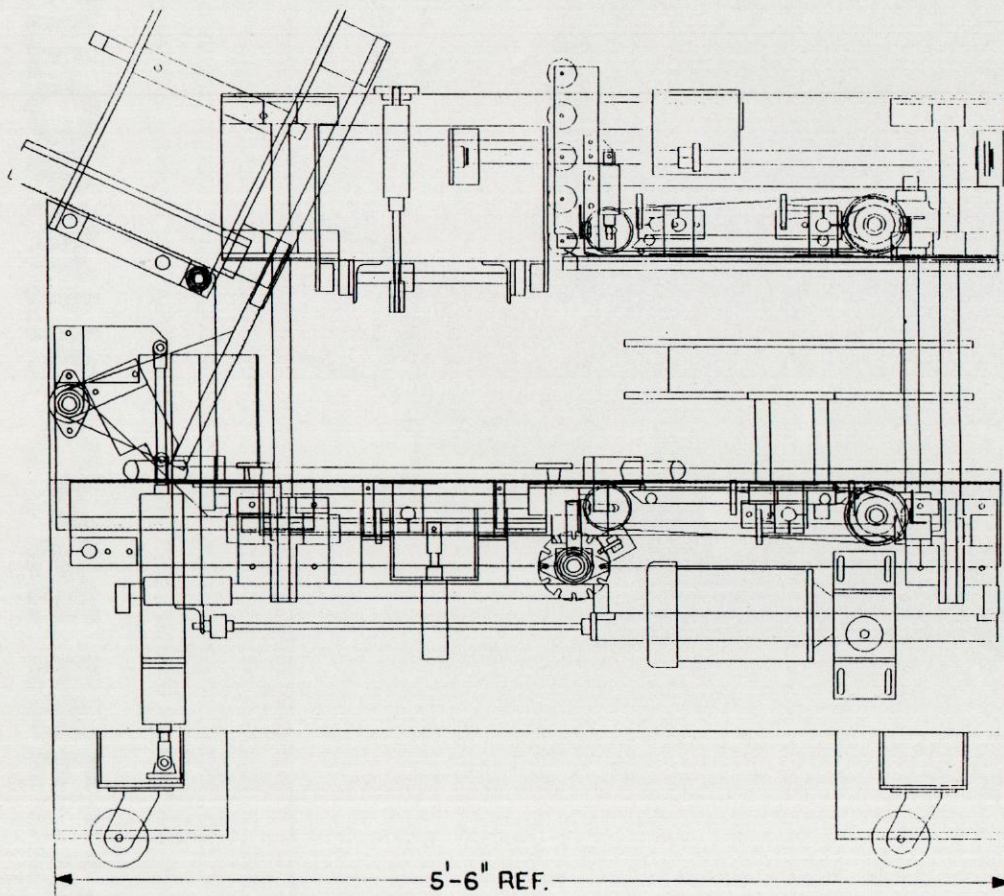

Packaging - Processing
Bid on Equipment
1-847-683-7720
www.bid-on-equipment.com