

# CH-3 AUTO-TRAC II CARTONER

Packaging - Processing  
**Bid on Equipment**

1-847-683-7720

www.bid-on-equipment.com

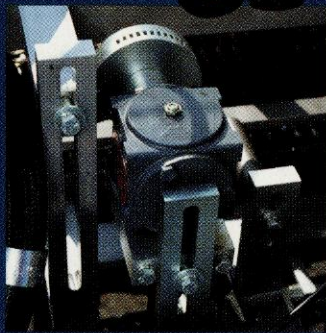
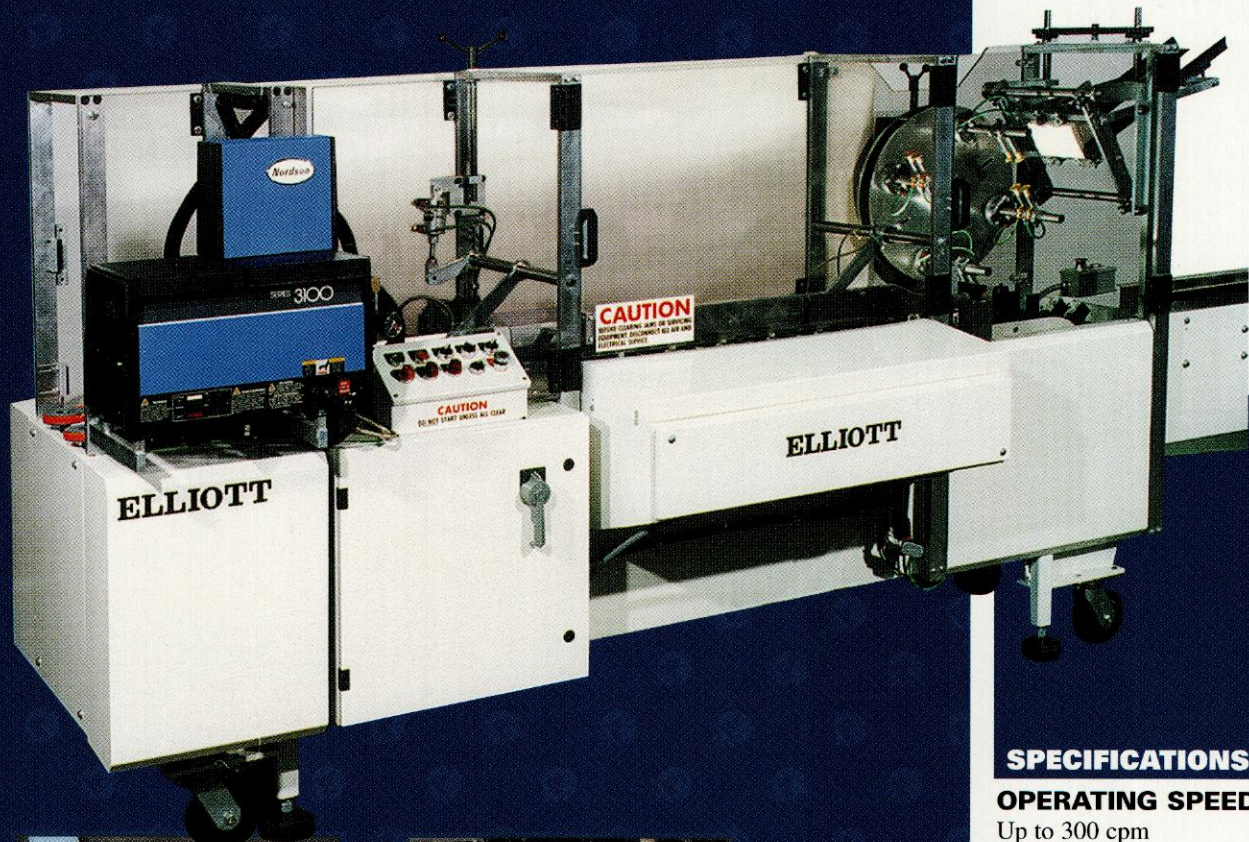

**Mechanical Deboss Coder**

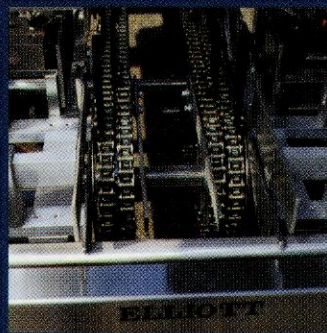

**Spline Shaft on Flight  
Drive System**

## SPECIFICATIONS

### OPERATING SPEEDS

Up to 300 cpm

### CARTON RANGE

Length 1" to 4-1/2"

Width 1/2" to 3"

Depth 2-1/2" to 6"

### OVERALL DIMENSIONS

Length 10'

Width 50"

Feed Height 36"

### ELECTRICAL

1-1/2 hp variable speed drive motor

460/230 volt, 3 phase, 60 hz

NEMA 12 electrical

The Elliott CH-3 Automatic Motion Cartoner offers quiet performance and proven reliability in an affordable and versatile package. Easily adaptable to a wide range of products, the CH-3 incorporates line shafting on the main lower drive as well as the entire flap folding system, minimizing the need for unwanted chains. Full perimeter guarding with interlock switches assure safety; powered discharge belt provides durability and value.

Standard features include: rotary carton erector, detented overload clutch, linear ball bushings in the insertion area and spline shaft on flight drive system.

*Elliott*  *Manufacturing Co.*

2664 S. Cherry • P.O. Box 11277 • Fresno, CA 93706  
209/233-6235 • FAX 209/233-9833 • Telex 355327 FSO

# CH-3 AUTO-TRAC II CARTONER

## FLOOR PLAN

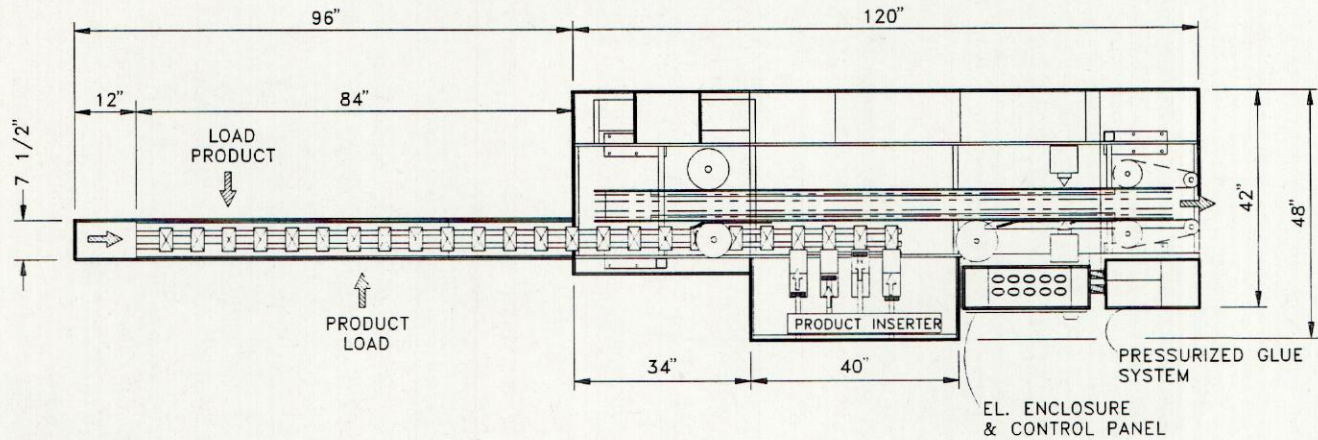

## ELEVATION

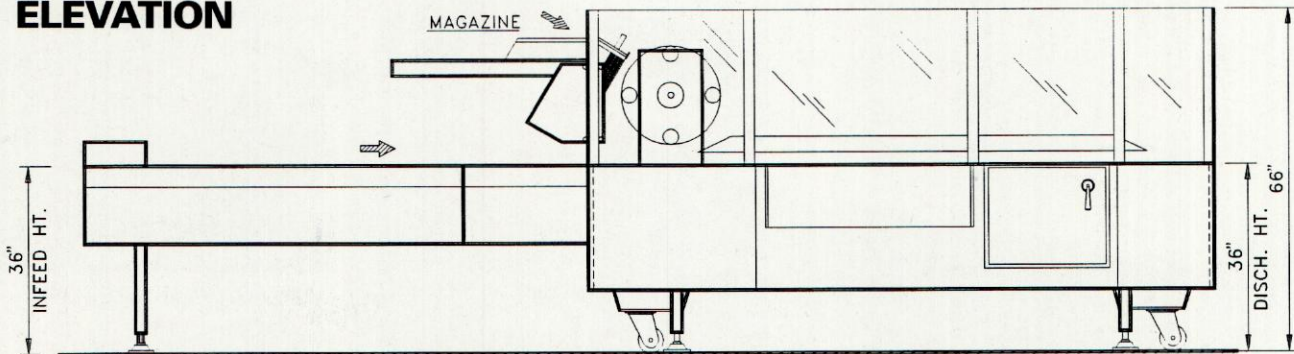

## SEQUENCE OF OPERATION

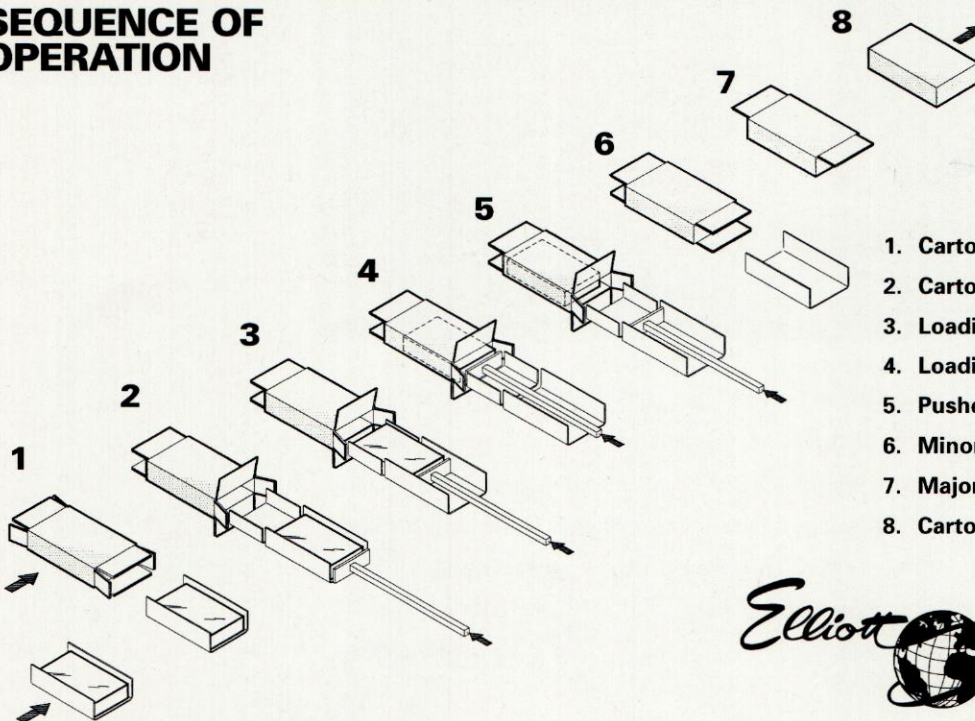

1. Carton is erected for the incoming product.
2. Carton flaps are prepared for loading.
3. Loading begins.
4. Loading is complete.
5. Pusher retracts, leaving product in carton.
6. Minor flaps are tucked.
7. Major flaps are plowed shut.
8. Carton is placed into compression.

*Elliott*  *Manufacturing Co.*