

ELLIOTT AUTOMATIC CASE TAPER

The Elliott Automatic Case Taper is a compact machine for sealing a wide range of case sizes in a limited space. It is quickly adjustable for changing case sizes. The taping machine is built within a single unitized machine frame. Squared cases are assured by case transfer system.

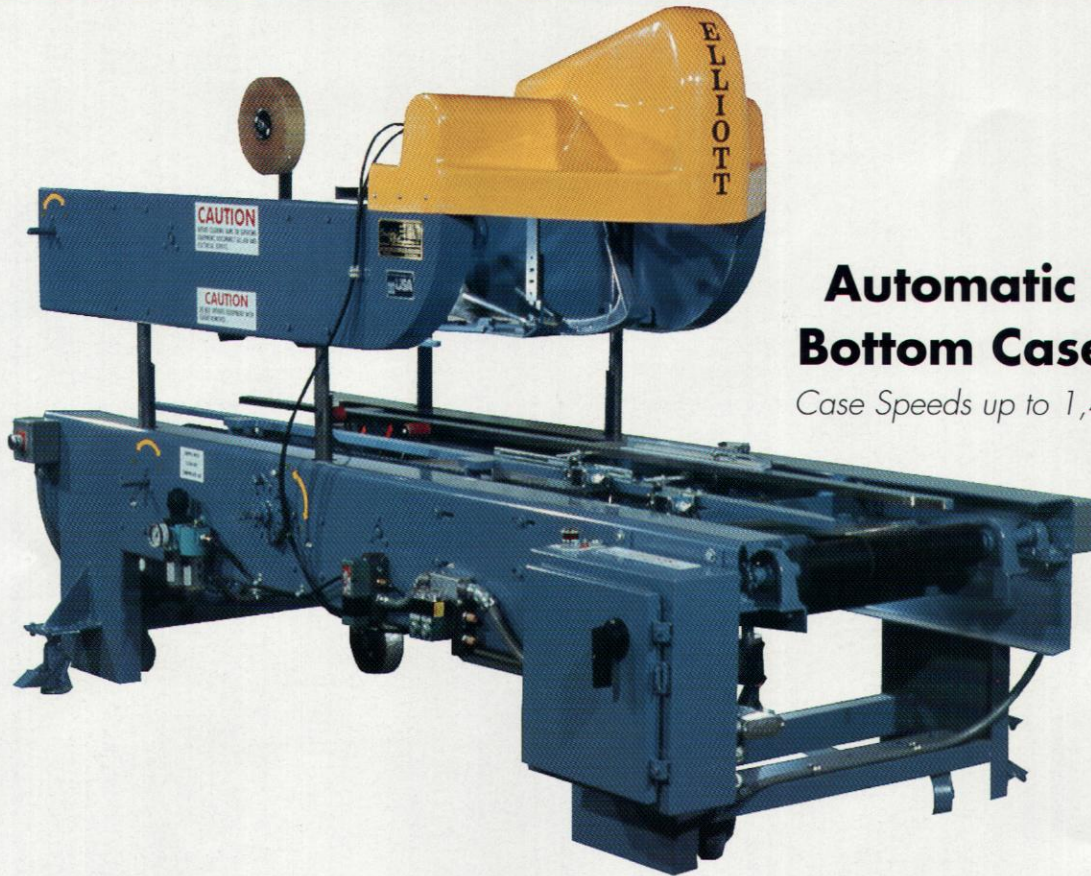

Automatic Top & Bottom Case Taper

Case Speeds up to 1,400 per hour

Comes complete with:

- Automatic Case Feeder Indexer
- Right-Hand Quick Change Crank Adjustments
- 460/230 volt, 3 phase, 60 hz
- Engraved Legend Plates for Switch Circuitry
- No Case/No Kick Automatic Flap Tucker
- NEMA 12 Electrical
- Safety Guards
- Motors, Drives, Electrical and Pneumatic Controls
- Identification & Function Plates

Machine Dimensions:

- 8'-6" Long
- 38" Wide
- 24" Infeed Height

Case Range:

- Length 8" to 23"
- Width 6-1/2" to 16"
- Height 4-1/2" to 16"

Elliott

**MANUFACTURING
COMPANY, INC.**

DESIGN ENGINEERS AND MANUFACTURERS OF FOOD PROCESSING AND PACKAGING MACHINERY

2664 S. Cherry
Fresno, CA 93706
Ph 209/233-8238
Fax 209/233-8988

P.O. Box 11277
Fresno, CA 93772

**Packaging - Processing
Bid on Equipment**

1-847-683-7720
www.bid-on-equipment.com

10934

| ITEM NO. | QTY. | DESCRIPTION OF MATERIALS | REMARKS |
|----------|------|--------------------------|---------|
|----------|------|--------------------------|---------|

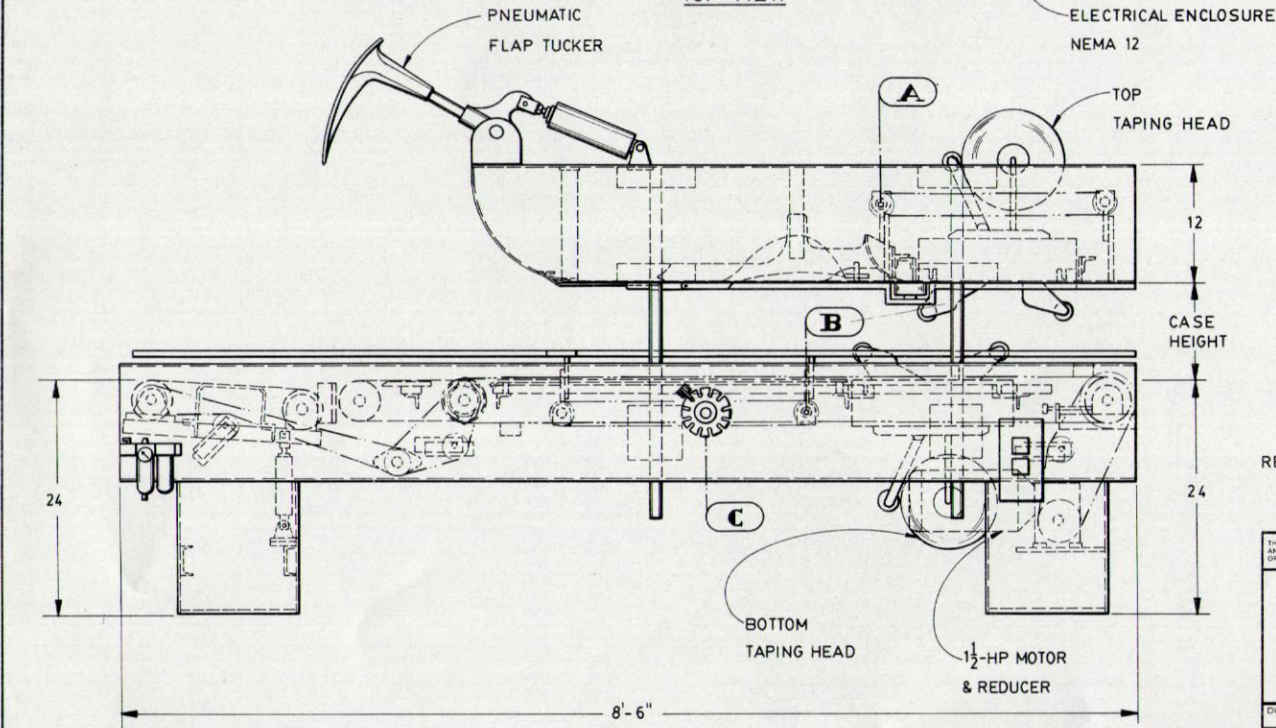
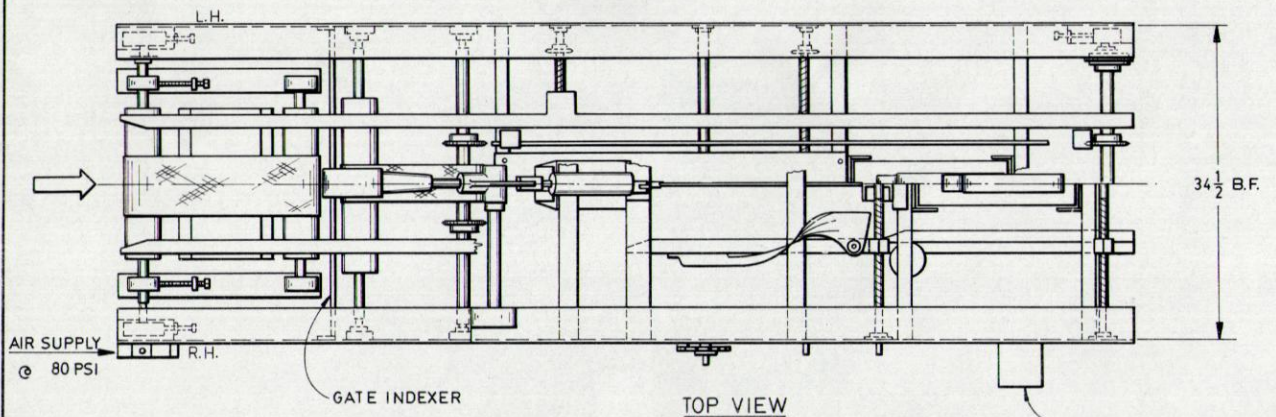

ADJUSTMENT STATIONS:

- A** = WIDTH ADJUSTMENT FOR TOP SIDE COMPRESSION BARS.
- B** = WIDTH ADJUSTMENT FOR BOTTOM SIDE COMPRESSION BARS.
- C** = HEIGHT ADJUSTMENT.

REF. DWG. NO's: 7544, 7545, 7546, 7547, 7548, 7549

THIS DRAWING IS THE PROPERTY OF THE ELLIOTT MFG. COMPANY, INC. THIS DRAWING IS LOANED WITHOUT OTHER CONSIDERATION THAN THE AGREEMENT AND CONDITION THAT IT IS NOT TO BE REPRODUCED, COPIED OR OTHERWISE DISPOSED OF, DIRECTLY OR INDIRECTLY, AND IS NOT TO BE USED IN WHOLE OR IN PART TO ASSIST IN MAKING OR TO FURNISH ANY INFORMATION FOR THE MAKING OF DRAWINGS, PRINTS OR PARTS THEREOF.



ENGINEERING DEPARTMENT

Manufacturing Co. INC.

FRESNO, CALIFORNIA 93772 FOOD, FRUIT AND SPECIAL MACHINERY

| | | |
|----------------------|----------------------|-----------|
| DWG. BY <i>A. W.</i> | OUTLINE DIMENSIONS | W/D NO. |
| DATE 11-22-88 | MODEL 85-AT | SHEET NO. |
| CHECKED BY | AUTOMATIC CASE TAPER | OF |
| SCALE | | DWG. NO. |
| REF. DWG. | | 7543 |

| NO. | DATE | REVISIONS |
|-----|------|-----------|
| | | |

Packaging - Processing
Bid on Equipment

1-847-683-7720

www.bid-on-equipment.com