

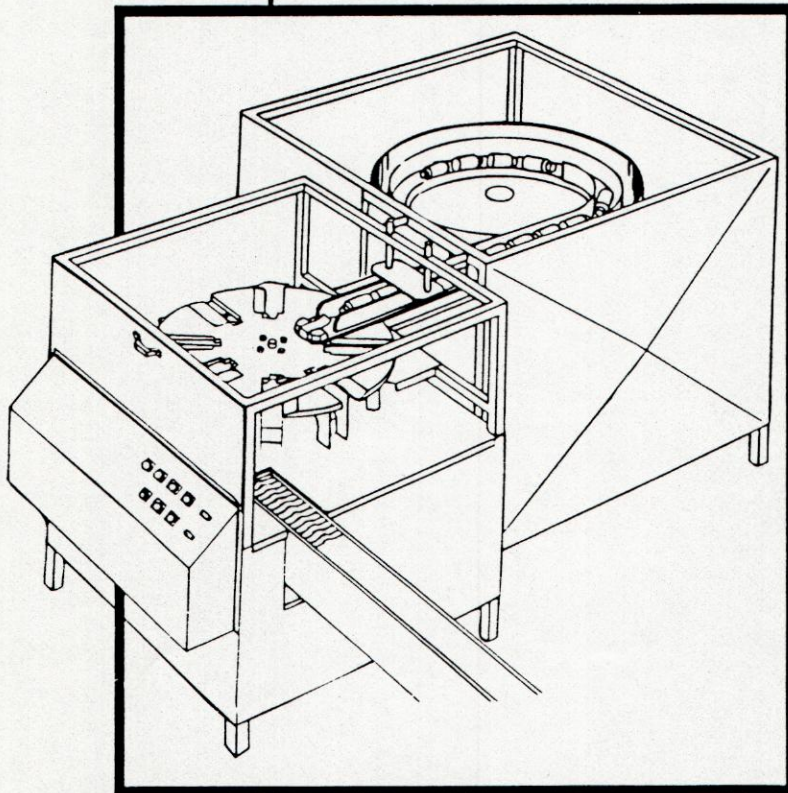

Bottle Unscrambler

Standard Bottle Unscrambler

Sorts random bottles and places them on a conveyor for entry into filling area.



Standard
Bottle
Unscrambler

SPECIFICATIONS

BOTTLE UNSCRAMBLER

- **Dimensions:**
width- 1.52 M (60") height- 1.37 M (54")
depth- 2.44 M (96")
- **Frame:** ..304 stainless steel "C" with wheels & leveling legs.
- **Air:** 80-100 PSI, 3-10 CFM (5.5-7 bar, 0.9-3.0M /min).
- **Electrical:** 110v, 60 hz, single phase 3.7 KVA.
- **Adjustment:** Speed of feeder & orientator are independently adjusted for optimum performance.
- **Anti Backup:** Electronic eye reads the container level in the chute. When chute is full, the containers are no longer sent to the chute reducing excess wear on containers.
- **Feed Bowl:** Centrifugal style, rotary bowl feeds the containers neck forward or back via a short air chute into the orientator. Adjust width & height of chute entry for different containers.
- **Orientator:** Rotating star wheel allows the containers to drop bottom down into pockets below & rotates around to place the container on the conveyor. Change star wheel assembly quickly for different container sizes.
- **Automatic Shut Down:** If containers are no longer being fed into the orientator, it shuts down awaiting containers.
- **Includes:** 5' (1.5M) stainless steel variable speed drive power conveyor.

NOTE: Evaluation & testing of samples required prior to construction to determine speeds, flexibility, final price and delivery.

**Packaging - Processing
Bid on Equipment**

1-847-683-7720

www.bid-on-equipment.com