

Relius™ DotMaker™

Operating Instructions

The Relius DotMaker 2000PD is a positive displacement dispensing gun for making repeatable deposits of low to medium viscosity materials.

The position of a volume control knob regulates the trigger stroke and, in turn, controls the volume displaced by the internal pump. Squeezing the trigger displaces the shot and releasing the trigger charges the chamber.

Follow this step-by-step guide to begin using your new Relius DotMaker 2000PD.

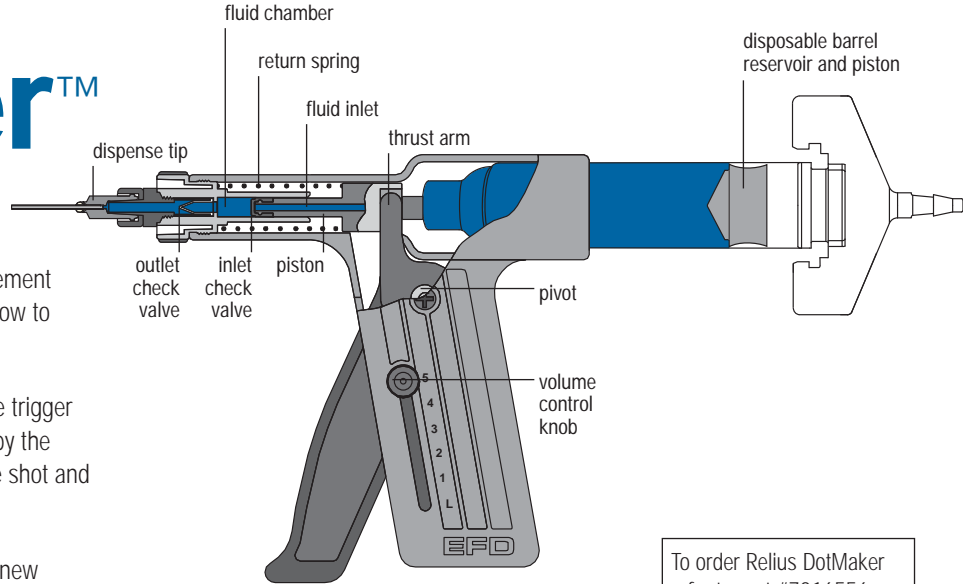

To order Relius DotMaker
refer to part #7016556.

The unique Relius DotMaker simplifies application of low to medium viscosity fluids.

It is very easy to use and less fatiguing than other manual applicators.

Features

- Rugged die cast zinc construction.
- Adjustable volume control.
- Designed specifically for use with Optimum Dispensing Components™ technology to eliminate drooling or dripping of fluids.
- Accepts five barrel sizes: 3cc, 5cc, 10cc, 30cc and 55cc.
- Quick change pump assembly for easy maintenance.

Specifications

Handle and Trigger: Die cast zinc with powder coat finish

Pump chamber: Polypropylene, nylon, aluminum

Check valves: Viton® (alternate EPR)

Output: Variable. 0.01 0.22 ml

Weight, gun only: 375 gm (13.4 oz)

This manual is for the express and sole use of Relius DotMaker purchasers and users, and no portion of this manual may be reproduced in any form.

The Relius DotMaker is patented by EFD, Inc.
Patent #D-403,933 ©2008

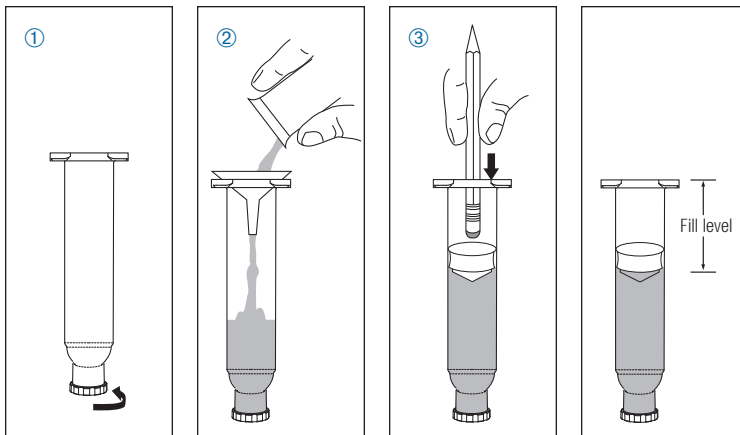

NOTE: The 2000PD performs best with fluids that pour and thixotropic materials which will move with pressure of 15 psi or less. Do not use high viscosity materials such as RTV silicone and heavy grease. Contact EFD for recommendations.

Filling the barrel reservoir

- ① Install an orange tip cap (#7017975).
- ② Load the fluid into the barrel, filling to the recommended level (see chart).
- ③ Insert a SmoothFlow™ white PE piston so that it just touches the fluid.

NOTE: For high volume applications, consider prefilled reservoirs from fluid packagers.

Barrel	Fill Level
3cc	5/8"
5cc	5/8"
10cc	3/4"
30cc	3/4"
55cc	3/4"

Setup

NOTE: Prime the 2000PD at the lowest possible volume setting to minimize waste during final volume adjustments..

- ① Loosen the volume control knob. Pull the trigger in while sliding the knob to the #1 position; then tighten the knob.
- ② Remove the orange tip cap from the end of the barrel reservoir.
- ③ Look into the inlet port and align the barrel reservoir with the inlet luer lock adapter. Press the reservoir in and twist to the right to secure.

Caution: Use light pressure to secure the reservoir.
Be careful not to overtighten.

- ④ Remove the tip cap from the outlet end of the 2000PD and install a dispensing tip. Use a small diameter tip for thin fluids or a larger one for thicker materials.

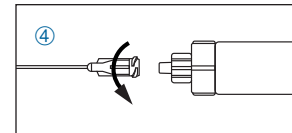
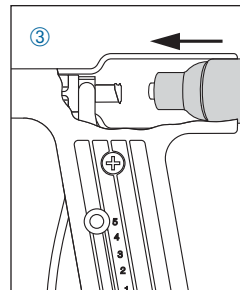
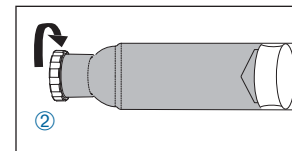
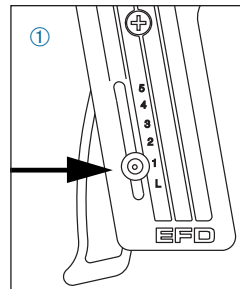

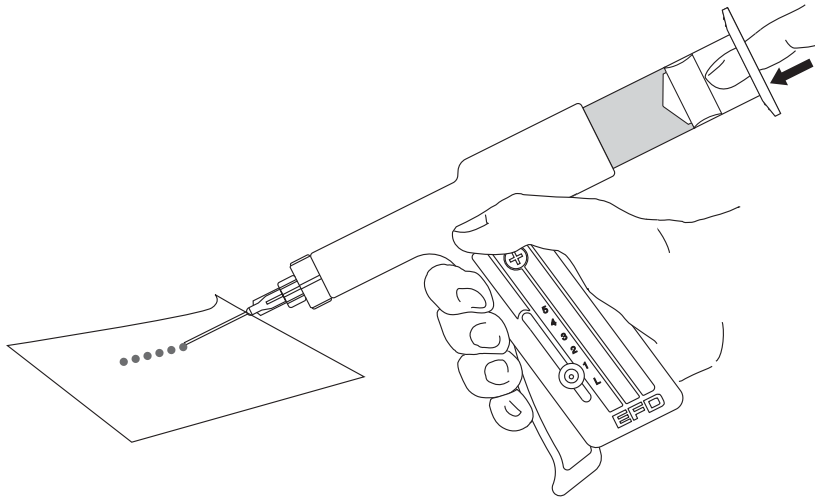

Priming the 2000PD

- ① Place the dispensing tip on the test paper and squeeze the trigger repeatedly (about 20 times) until fluid begins to dispense.
- ② With thicker material, it may help to apply light pressure on the piston while squeezing the trigger

Continue to dispense until fluid flows free of air.

Operating the 2000PD

NOTE: Sufficient time must be allowed for the chamber to refill between deposits. Thicker materials require more time (1 to 2 seconds). When deposits begin to decrease from shot to shot, it is an indication that more time is required between shots.

- ① The position of the volume control knob determines the deposit volume. Position the knob near #1 for low volume and toward #5 for higher output.
- ② To adjust the volume control knob, place the dispensing tip on the test paper. Squeeze and hold the trigger in (some material will dispense). Loosen the knob and slide it to the desired position; then tighten the knob and release the trigger.

For best results, hold the dispensing tip at a 45° angle and in contact with the work surface. Use the test sheet to practice.

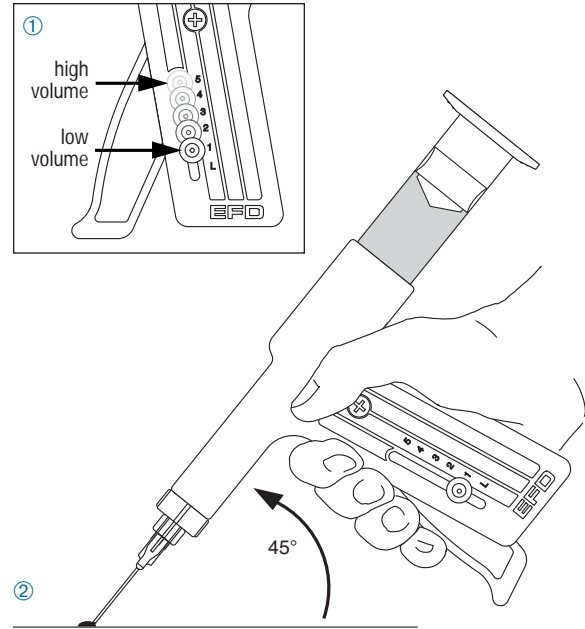

Recommendations

- The Relius DotMaker has Viton® seals which work well with most fluids. If your fluid reacts with Viton®, order pump assembly #7016557 with ethylene propylene seals.
- Do not use the Relius DotMaker with cyanoacrylate instant-cure adhesives. Contact EFD for recommendations.
- Anaerobic sealants and thread-locking materials can be dispensed but should be purged at the end of the day to avoid curing inside the pump.
- UV-cure adhesives work best with the EPR pump assembly #7016533.
- Certain high viscosity materials can be dispensed; however, they require more time to fill the chamber between shots.

*Contact EFD if you have questions or need us to evaluate a material:
 800-556-3484.*

Fluid Compatibility

anaerobics	•
coatings	•
cyanoacrylates	X
gel cyanoacrylates	X
carpenter's glue	•
white glue	•
epoxies	X
inks	•
grease	•
oils	•
sealants	•
silicones	•
solder pastes	X
braze pastes	X
solvents	•
UV cure	•

Key

- recommended
- conditional
- X do not use

Maintenance & Cleaning

Purging

To perform a simple purge procedure, remove tip and install a reservoir filled with an appropriate cleaning solution. Set the volume control knob to #5 and operate the trigger until all the solution has been dispensed through the gun. Repeat if necessary.

Pump Replacement

- ① Remove the fluid reservoir.
- ② Remove the dispensing tip.
- ③ Set volume control knob to #5.
- ④ Squeeze the trigger until the remaining material is cleared from the gun.

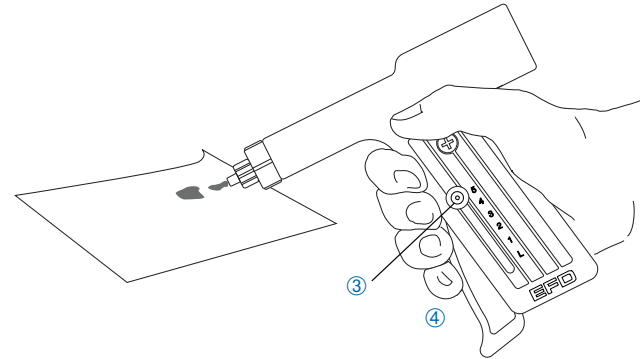
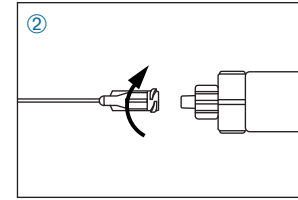
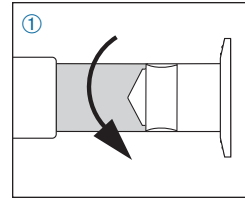

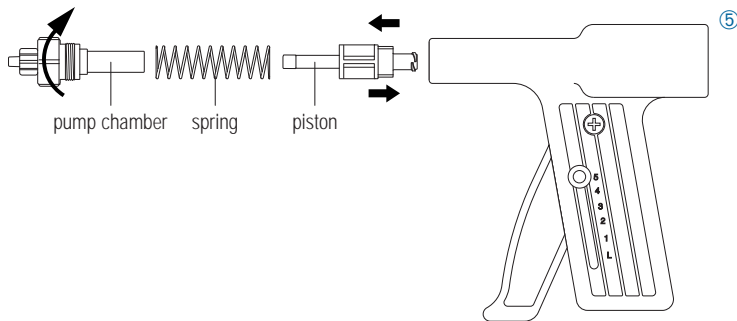

- ⑤ Remove the pump assembly and spring from the front by unthreading the pump chamber to the left (counterclockwise).

Separate the piston from the chamber and save the spring.

- ⑥ Install the replacement pump assembly, part #7016557 (Viton®) or alternate #7016533 (ethylene propylene):

a. Separate the piston from the chamber.

b. Install the piston into the front of the gun. Look through the back of the gun and align the flats on the piston with the thrust arm on the trigger.

c. Insert the pump chamber and spring through the front of the gun and hand tighten to the right (clockwise).

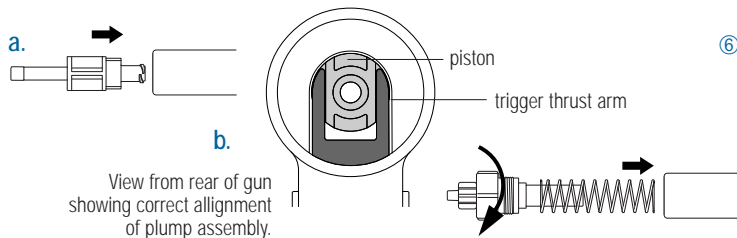

Troubleshooting

The 2000PD will not prime or dispense.

One of the check valves is not closing properly. Purge the gun with cleaner or replace the pump assembly.

The material is too thick.

The seals may have reacted and swelled. Replace with the alternate EPR pump assembly #7016533.

The 2000PD drips after the deposit.

There is air in the dispensing tip. Operate the gun until the air is dispelled.

The seals may have reacted and swelled. Replace with the alternate EPR pump assembly #7016533.

*For further assistance, contact EFD at: **800.556.3484** or technical@efd-inc.com*

Accessories and Parts

Molded Field Case

Durable, molded carrying case protects the 2000PD. Includes space for accessories.

Part #7023956

Illuminator™

Flashlight and attachment to light up recesses for accurate dispensing. Spot or flood beam.

Part #7023957

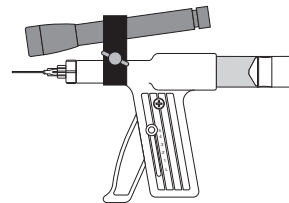

Accessories and Parts

Barrels/pistons: Each box contains the same quantity of barrels and pistons.

part #	description
7012074	(50) sets for 3cc size gun
7012096	(40) sets for 5cc size gun
7012114	(30) sets for 10cc size gun
7012136	(20) sets for 30cc size gun
7012153	(15) sets for 55cc size gun

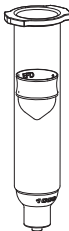

Snap-tight barrel end caps: These caps ensure sealing of filled barrels for storage. Finger tab for easy removal.

part #	size	qty/box
7012190	3cc	(50)
7012192	5cc	(40)
7012194	10cc	(30)
7012196	30cc/55cc	(20)



Smooth-flow tapered tips: Molded polyethylene. Packaged (50) tips per box.

tapered	gauge	ID	color
7018052	14	.063"	olive
7018100	16	.047"	grey
7018158	18	.033"	green
7005009	20	.023"	pink
7018298	22	.016"	blue
7018391	25	.010"	red
7018417	27	.008"	clear

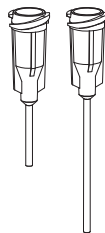

Barrel tip caps: Seals barrel outlet for storage. One size fits all barrels.

part #	qty/box	color
7012198	50	blue
7012269	50	black



Replacement Pump

Screw-in replacement pump assembly/seals for the 2000PD. Available in Viton® and ethylene propylene.

Viton®	#7016557
EPR	#7016533



General-purpose precision tips: Stainless steel tips with color-coded polypropylene hubs .05" and 1.0" free lengths. Packaged (50) tips per box.

0.5" tip	1.0" tip	gauge	ID	color
7018043	7018032	14	.060"	olive
7018068	7018059	15	.054"	amber
7018122	7018110	18	.033"	green
7018178	7018166	20	.023"	pink
7018233	7018222	21	.020"	purple
7018272	7018263	22	.016"	blue
7018314	7018305	23	.013"	orange
7018345	7018336	25	.010"	red
7005008	n/a	27	.008"	clear
7018433	n/a	30	.006"	lavender