



Welcome to the ProcessMate Temperature Control Unit, the most efficient process environmental control system on the market. This User's Guide will help you maximize the usefulness of your new ProcessMate.

Please spend a few minutes to become familiar with the controls and features. Review the helpful information we have included, which is based on more than 30 years of industrial process and dispensing experience.

Most questions you will have are answered in this guide. However, if you need assistance, please do not hesitate to contact EFD or your authorized EFD distributor.

In the USA, call 800-338-4353 between 8:30 a.m. and 5:30 p.m. Eastern time.

In Europe, call +44 (0) 1582 666334.

In Asia, call +86 (21) 3866 9006.

In all other areas, call your authorized EFD distributor or +1-401-431-7000.

---

### The EFD Pledge

We pledge that you will be completely satisfied with our products. We endeavor to ensure that every EFD product is produced to our no-compromise quality standards.

If you feel that you are not receiving all the support you require, or if you have any questions or comments, I invite you to write or call me personally.

Our goal is to build not only the finest equipment and components, but also to build long-term customer relationships founded on superb quality, service, value and trust.

Peter Lambert, President

---

Safety. . . . . 4-5

Specifications. . . . . 6

Schematic / Parts List. . . . . 7

Getting Started . . . . . 8-9

Features and Controls. . . . . 10-11

    Front and Rear Panels . . . . . 10

    Front Panel Digital Display . . . . . 11

Configuration . . . . . 12

Care and Preventative Maintenance. . . . . 13

Frequently Asked Questions . . . . . 14

Troubleshooting . . . . . 15

Warranty and Support . . . . . Back Cover

## Introduction

Read and follow these safety instructions. Task- and equipment-specific warnings, cautions and instructions are included in equipment documentation where appropriate.

## Qualified Personnel

Equipment owners are responsible for making sure that EFD equipment is installed, operated and serviced by qualified personnel. Qualified personnel are those employees or contractors who are trained to safely perform their assigned tasks. They are familiar with all relevant safety rules and regulations, and are physically capable of performing their assigned tasks.

## Intended Use

Use of EFD equipment in ways other than those described in the documentation supplied with the equipment may result in injury to persons or damage to property.

Some examples of unintended use of equipment include, but are not limited to:

- Using incompatible materials
- Making unauthorized modifications
- Removing or bypassing safety guards or interlocks
- Using incompatible or damaged parts
- Using unapproved auxiliary equipment
- Operating equipment in excess of maximum ratings

## Regulations and Approvals

Make sure all equipment is rated and approved for the environment in which it is used. Any approvals obtained for EFD equipment will be voided if instructions for installation, operation and service are not followed.

## Personal Safety

To prevent injury follow these instructions.

- Do not operate or service equipment unless you are qualified.
- Do not operate equipment unless safety guards, doors or covers are intact and automatic interlocks are operating properly. Do not bypass or disarm any safety devices.
- If you receive even a slight electrical shock, shut down all electrical equipment immediately. Do not restart the equipment until the problem has been identified and corrected.
- Obtain and read Material Safety Data Sheets (MSDS) for all materials used. Follow the manufacturer's instructions for safe handling and use of materials, and use recommended personal protection devices.
- To prevent injury, be aware of less-obvious dangers in the workplace that often cannot be completely eliminated, such as hot surfaces, sharp edges, energized electrical circuits and moving parts that cannot be enclosed or otherwise guarded for practical reasons.
- This equipment is for indoor use only.
- Use only the power adapter provided with the unit. Contact EFD to purchase a replacement adapter.

## Fire Safety

To avoid a fire or explosion, follow these instructions.

- Shut down all equipment immediately if you notice static sparking or arcing. Do not restart the equipment until the cause has been identified and corrected.
- Do not smoke, weld, grind or use open flames where flammable materials are being used or stored.
- Provide adequate ventilation to prevent dangerous concentrations of volatile particles or vapors. Refer to local codes or your material MSDS for guidance.
- Do not disconnect live electrical circuits when working with flammable materials. Shut off power at a disconnect switch first to prevent sparking.
- Know where emergency stop buttons, shutoff valves and fire extinguishers are located.
- Clean, maintain, test and repair equipment according to the instructions in your equipment documentation.
- Use only replacement parts that are designed for use with original equipment. Contact your EFD representative for parts information and advice.

## Action in the Event of a Malfunction

If a system or any equipment in a system malfunctions, shut off the system immediately and perform the following steps:

- Disconnect and lock out system electrical power.
- Identify the reason for the malfunction and correct it before restarting the system.

## Disposal

Dispose of equipment and materials used in operation and servicing according to local and national codes.

## China RoHS Hazardous Material Declaration

Part Name	Toxic or Hazardous Substances and Elements					
	Lead (Pb)	Mercury (Hg)	Cadmium (Cd)	Hexavalent Chromium (Cr6)	Polybrominated Biphenyls (PBB)	Polybrominated Diphenyl Ethers (PBDE)
All brass fittings	<b>X</b>	<b>0</b>	<b>0</b>	<b>0</b>	<b>0</b>	<b>0</b>
<p><b>0</b>: Indicates that this toxic or hazardous substance contained in all the homogeneous materials for this part, according to EIP-A, EIP-B, EIP-C is below the limit requirement in SJ/T11363-2006.</p> <p><b>X</b>: Indicates that this toxic or hazardous substance contained in all the homogeneous materials for this part, according to EIP-A, EIP-B, EIP-C is above the limit requirement in SJ/T11363-2006.</p>						

## Specifications

Cabinet size: 18.9 W x 7.1 H X 15.9 D cm (7.5 x 2.8 x 6.3")

Weight: 1.0 kg (2.2 lbs)

Input AC (to power supply): 100-240VAC(+/-10%) ~, 50/60Hz, 0.6A

Output DC (from power supply): 24 VDC, 1.04 A maximum

Power Requirements: 24 VDC, 1.04 A maximum

Standard air input: \*40 to 110 psi (2.8 to 7.5 bar)

**\*WARNING: DO NOT exceed 110 psi (7.5 bar) or damage to the unit may occur.**



Air usage: Up to 55 L/min (3 CFM). See page 11 for details.

Temperature control: +/- 0.1°C from 10°C to 40°C (50°F to 104°F)

### Ambient operating condition limits:

Temperature: -10°C to 55°C (14°F to 131°F)

Humidity: 85% RH at 30°C non-condensing

Height above sea level: 2000 meters max (6,562 feet)

Under normal operating temperatures, the ProcessMate 6500 can maintain dispense process chamber set point within +/- 0.1°C, from 10°C to 40°C (50°F to 104°F). Normal operating conditions are considered to be an ambient air feed between 15°C and 27°C (60°F and 80°F). The ProcessMate 6500 will operate quite effectively outside of these temperatures, but it will affect the maximum and minimum temperatures the unit can generate.

Note: Specifications and technical details are subject to change without prior notification.

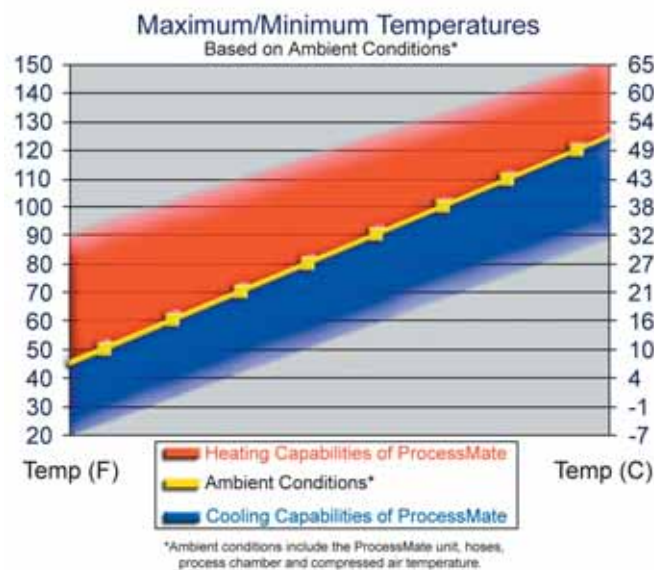

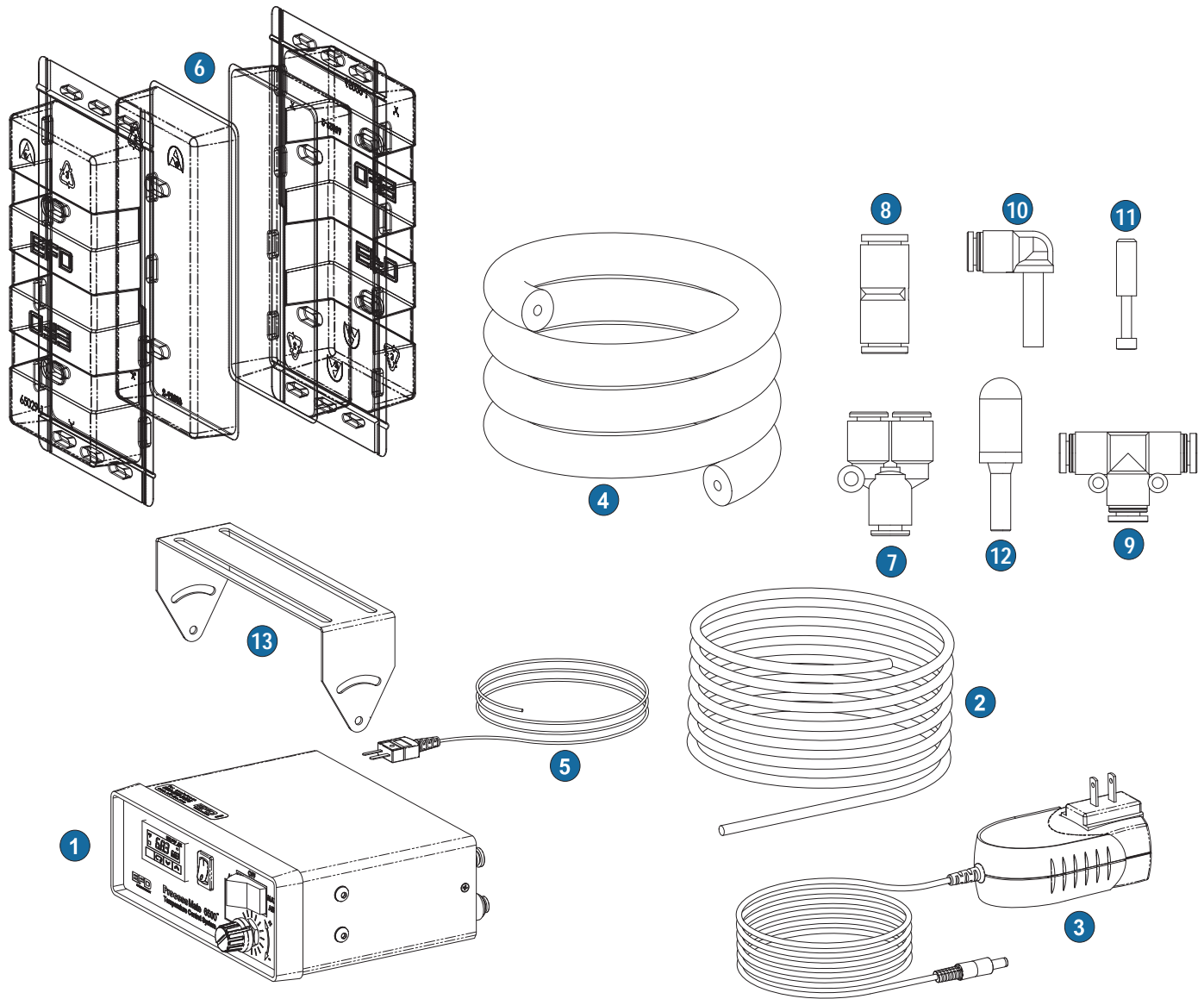

## Parts List

Part Number	Description	Quantity	Part Number	Description	Quantity
1. 7020341	6500 console	(1)	8. 7020373	Fitting, union strt, 6 mm push-in	(1)
2. 7002004	Tubing-6 mm OD, urethane, blue	14.5-ft	9. 7020375	Fitting, union tee, 6 mm push-in	(1)
3. 7015199	25W universal power supply	(1)	10. 7020377	Fitting, stem elbow, 6 mm push-in	(2)
4. 7020364	Insulation, 1/4" ID X 3/8" wall	6-ft	11. 7022208	Plug-6 mm push-in	(2)
5. 7020366	Thermocouple, K type	(1)	12. 7020356	Muffler, 6 mm push-in	(3)
6. 7020368	Temp control chamber	(1)	13. 7020800	Pivot bracket	(1)
7. 7020371	Fitting, union "Y", 6 mm push-in	(1)			

## Unpack the Unit / Warranty

1

- Use the checklist enclosed with the ProcessMate to identify all items. If there is any discrepancy, please call us immediately.
- Now is a good time to activate your One Year Warranty. Register the warranty online at [www.efd-inc.com/warranty/one](http://www.efd-inc.com/warranty/one). Or if you prefer, follow the instructions in the enclosed "Welcome" letter to contact your EFD representative.

## Connect Power

2

- Connect the power plug to the power pack. The unit is shipped with a USA-compatible plug and three international plugs. Attach the correct plug to match local power outlets.
- Connect the power cord into the back of the ProcessMate.
- Connect the power cord into your local power source.



## Connect Air Input

3

*NOTE: Clean, dry, filtered factory air is required to meet the warranty. If your air supply is not filtered, order the EFD five micron filter regulator (EFD part# 2000F755).*

- Push one end of the air input hose into the input fitting on the back of the ProcessMate.
- Connect the other end of the hose to your plant air supply.
- Set plant air supply within 80 to 100 psi (5.5 to 6.9 bar).
- DO NOT exceed 110 psi (7.5 bar) or damage to the unit may occur.



## Connect Thermocouple

4

- Plug K-type thermocouple lead into the back panel of ProcessMate.
- Connect the other end of the lead to process hardware.

**\*Option:** Can route thermocouple lead with either air line tubing inside insulation. See directions below.

*NOTE: Longer Thermocouple leads may be used when required. These are available from a variety of sources in many lengths. Only K-Type thermocouple leads should be used with the ProcessMate. Using a different type will result in incorrect temperatures.*



## Attach Process Feed Lines

5

- Slide insulation over cold process feed line.
- Slide insulation over hot process feed line.
- \*Option:** Can route thermocouple lead with either hot or cold process feed line.

- Insert cold process feed line into the cold process fitting.
- Insert hot process feed line into the hot process fitting.



## Connect Exhaust Mufflers

6

- Insert a muffler into each exhaust port for both cold and hot feed exhausts.

*NOTE: Tubing can be purchased as an accessory to route for remote exhaust in lieu of mufflers.*



Features & Controls:  
Front & Rear Panels

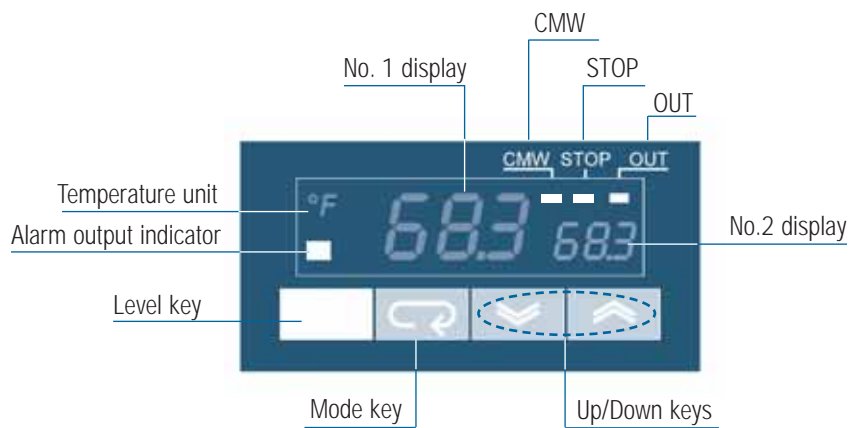
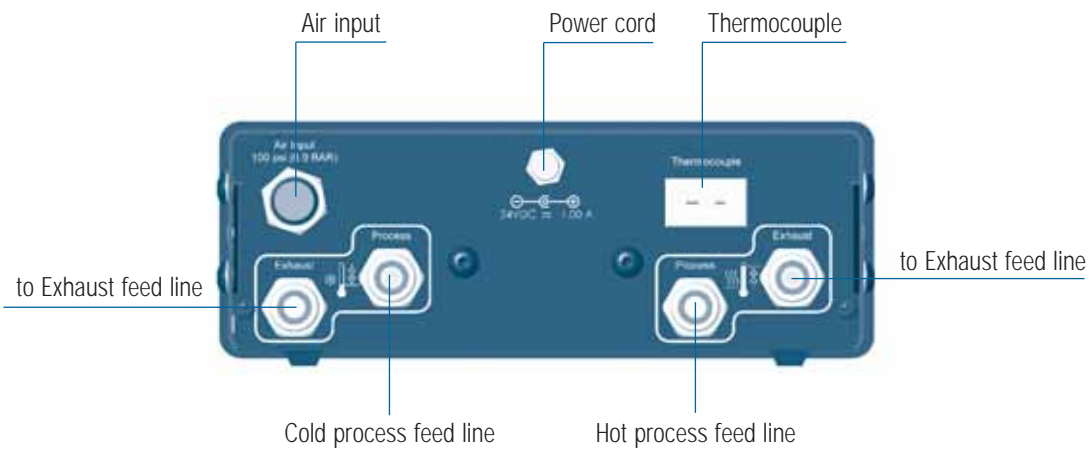
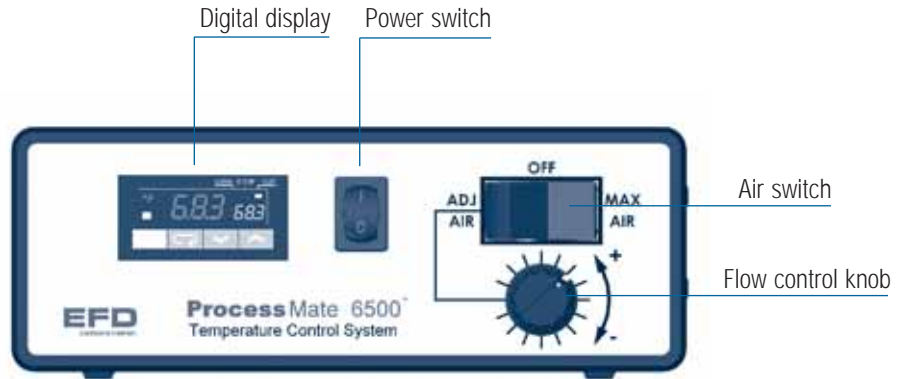

## Digital Display

<b>Level key</b>	Use to access advanced features of the controller. (Refer to manufacturer's documentation supplied with unit.)	
<b>Mode key</b>	Use to access advanced features of the controller (Refer to manufacturer's documentation supplied with unit.)	
<b>No. 1 display</b>	Actual temperature as measured by the thermocouple.	
<b>No. 2 display</b>	Process temperature set point.	
<b>Up/down keys</b>	Use the keys to change the temperature set point value displayed on the No. 2 display.	
<b>AI</b>	Alarm indicator light—this will light up whenever the unit is adding cold air to the process.	
<b>CMW</b>	Communications writing enable/disable indicator lights	Advanced features <b>NOT</b> used by ProcessMate
<b>STOP</b>	Control stop indicator	
<b>OUT</b>	Control output 1 & 2 indicators	

## Change from Centigrade to Fahrenheit

- Hold down the Level Key for 3 seconds. [Cn-t] will appear.
- Press the Mode Key [d-u] will appear.
- Press the Up arrow key to change from C to F or vice-versa.
- Return to the Temperature Display by holding the Level Key for 3 seconds

## Air Settings

- OFF (Center)** Stops all air from flowing through the unit.
- MAX Air** Maximum air flow through the unit (approximately 3 CFM or 85 LPM). This also produces the maximum degree of heating or chilling. Once near to the desired temperature, the "ADJ AIR" setting should be used.
- ADJ Air (left)** Adjustable Air setting is used to precisely control the air flow. The knob is labeled with +/- markings and allows more or less air to reach the process. Set the knob to the minimum amount required to maintain the desired temperature.

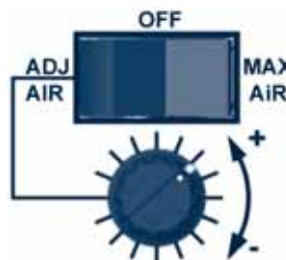

## Configuration

The ProcessMate can be plumbed in a variety of configurations depending on your specific needs. All of the hardware required for each of these setups is included with your unit.



### Configuration A

Applications requiring both heating and chilling capabilities. (Facilities or machines which experience temperature fluctuations above and below the required process temperature require both hot and cold.)



### Configuration B

Applications requiring both heating and chilling in a compact space. Hot and cold airstreams may be joined together with the supplied "Y" fitting. (The unit will cycle more often as the common tube retains some of the thermal energy.)



### Configuration C

A process that only requires cold air flow. (Ambient conditions are well above desired temperature within the chamber.)



### Configuration D

A process that only requires hot air flow. (Ambient conditions are well below desired temperature within the chamber.)



The ProcessMate and accessories will last a long time if they are maintained properly and handled with care.

- The ProcessMate should be kept clean and dry.
- Make sure the unit is unplugged when conducting maintenance on the unit.
- Clean the unit with a damp sponge or cloth. Use warm water and mild soap solution, if required. **DO NOT allow drips or excess water inside the unit. DO NOT spray or pressure wash unit.**
- The ProcessMate does not have any user serviceable parts inside. Removing the protective housing will void the product warranty.
- External parts should be monitored for wear. Inspect the tube insulation regularly for signs of aging and cracking. Inspect air fittings for signs of leakage.
- Contact EFD for replacement parts.

## Can I Modify the Clamshell Process Chambers?

**YES.**

- The clamshell process chambers (sold separately) are simple and easy to modify.
- The plastic can be cut to customize the box to fit individual process requirements.
- **The boxes are disposable.** If the box becomes soiled or damaged, replacements are readily available from EFD.

## Can I Make My Own Process Chamber?

**YES.** For those who wish to make their own process chamber, please follow the guidelines outlined below:

- The chamber should cover the entire material path (syringe, valve, fittings, etc, leaving only the needle or exit point exposed).
- The chamber should have a minimum of “dead air” space. The less space inside the chamber, the easier it is to maintain temperatures within.
- The chamber should allow the heated/chilled air to circulate freely around the process hardware within.
- The chamber must have a vent that allows air to exit the chamber. Plan ahead to determine where the heated/chilled air can freely enter, circulate, and then exit the chamber.
- The chamber should either be made of transparent materials, or be provided with a window to allow monitoring of material levels.
- In order to maintain temperatures well above or below ambient conditions, the chamber should be made from or contain an insulated material or have double-walled construction. This will help to maintain desired temperatures.

If you encounter a problem that you cannot readily solve, call EFD.

Trouble	Possible cause and correction
---------	-------------------------------

<b>No power</b>	<ol style="list-style-type: none"> <li>1. Be sure that there is power available at the wall receptacle.</li> <li>2. Unplug the unit. Make sure AC/DC power supply's main plug adapter is firmly seated and locked on the supply body.</li> <li>3. Make sure that the power lead is firmly inserted and seated at the rear of the unit.</li> <li>4. If the unit still does not have power, please call EFD for assistance.</li> </ol>
-----------------	--------------------------------------------------------------------------------------------------------------------------------------------------------------------------------------------------------------------------------------------------------------------------------------------------------------------------------------------------------------------------------------------------------------------------------------



<b>Unit will not maintain pre-set temperature</b>	<ol style="list-style-type: none"> <li>1. Make sure the thermocouple is solidly plugged into rear of the unit and lead is affixed to process hardware.</li> <li>2. Check incoming air pressure and flow. For maximum efficiency, the unit must be supplied with 100 psi (6.9 bar) of clean, dry air.</li> <li>3. If the pressure is fluctuating or dropping, the unit efficiency will be reduced. Insufficient airflow will cause degradation to the minimum and maximum temperatures the unit can provide.</li> <li>4. Check air pressure to ensure that it is not varying. If needed, use the filter regulator (EFD part #2000F755).</li> <li>5. Slow drop or rise from the desired temperature (usually over the course of several hours) can be moisture inside the air supply causing freezing inside the unit. This will reduce the airflow, and degrade the minimum and maximum temperatures the unit can provide.</li> </ol> <p>To properly diagnose if this is occurring, shut off the unit for several minutes to allow the potential blockage to thaw. Turn the unit back on. If the temperature resumes the required set point, it is a sure sign that moisture is present.</p> <p>If your process is not dependent on the unit running continuously, shut down the unit in between runs to prevent moisture buildup in the unit.</p> <p>The preferred method is to install line dryers: refrigerant type, inline desiccant, or membrane dryers. The desiccant and membrane type dryers have been shown to produce substantial dew point reductions, and are the preferred method to reduce moisture in the unit. These are available from EFD.</p>
---------------------------------------------------	-----------------------------------------------------------------------------------------------------------------------------------------------------------------------------------------------------------------------------------------------------------------------------------------------------------------------------------------------------------------------------------------------------------------------------------------------------------------------------------------------------------------------------------------------------------------------------------------------------------------------------------------------------------------------------------------------------------------------------------------------------------------------------------------------------------------------------------------------------------------------------------------------------------------------------------------------------------------------------------------------------------------------------------------------------------------------------------------------------------------------------------------------------------------------------------------------------------------------------------------------------------------------------------------------------------------------------------------------------------------------------------------------------------------------------------------------------------------------------------------------------------------------------------------------------------------------------------------------------------------------------------------------------------------



<b>Condensation forms on the tubing</b>	<ol style="list-style-type: none"> <li>1. Condensation may form on the process supply tubing if temperature set points are well below ambient room temperature and relative humidity is high.</li> <li>2. Tube insulation supplied with the unit will prevent condensation from forming and will also increase overall efficiency.</li> </ol>
-----------------------------------------	-----------------------------------------------------------------------------------------------------------------------------------------------------------------------------------------------------------------------------------------------------------------------------------------------------------------------------------------------