

MicroCoat[®] System Operating Manual

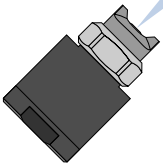

MC4000 Series

MC785M, MC785M-WF Spray Valves

Introduction

The MicroCoat® System provides precise lubrication control for metal stamping operations.

The MC4000 controller, MC785M series spray valves and the MicroCoat tank reservoirs are all produced to exacting specifications and thoroughly tested prior to shipment.

The MC785M series valves are designed for long life without maintenance when clean lubricant is used.

To obtain the maximum performance from your MicroCoat® System, please read through these instructions carefully.

Our goal is to build not only the finest equipment but also to build long-term customer relationships founded on superb quality, service, value and trust.

**If you have any questions,
please contact us for assistance.**

.....

US 800-498-8865

UK 0800 585733

Mexico 001-800-556-3484

Fax +1-401-431-0237

Contents

- Specifications 4
- How the System Operates 5
- Controller Features 6-7
- Tank Reservoir Features 8
- System Assembly 9-15
- Step 1: Mount the Spray Valves 9
- Step 2: Set Up the Controller 10
- Step 3: Connect the Press Air Solenoid 10-11
- Step 4: Connect the Valve Hoses 12-13
- Step 5: Connect the Tank Reservoir &
Lubricant Filter 12-13
- Step 6: Connect the Emergency Stop Circuit 14-15
- System Setup 16-17
- Fill the Tank Reservoir 16
- Prime the System 16
- Adjust the Spray 17
- Preventive Maintenance 17
- Spray Valve Maintenance 18
- Spray Valve Exploded View & Part Numbers 19
- Controller Air Schematic 20
- Oil Flow Schematic 20
- Controller and Tank Replacement Part Numbers 21
- Troubleshooting Guide 22
- Accessories 23
- Warranty back cover

Specifications

MC785M & MC785M-WF Spray Valves

Size (with fittings): 2.61" (66.29 mm) length
1.94" (49.28 mm) width

Weight: 7.28 oz (206 gr)

Lubricant chamber: Hard-coated aluminum

Return spring: Type 303 stainless steel

Needle and nozzle: Type 303 stainless steel

Air cap: Type 303 stainless steel

Diaphragm: Viton® with Teflon® coating

Lubricant inlet hole: 1/8 NPT

Mounting: M6 tapped hole

Operating frequency: Up to 60 per minute

Nozzle diameter: 0.046" (1.17 mm)

U.S. Patent # D-398, 705

CE Compliant

Satisfies machine directive 89/392/EEC

Evaluated to EN983:1996

Note: Specifications and technical details are subject to engineering changes without prior notification.

MC4000 Controller

Cabinet size: W 5.12" x D 7.50" x H 10.00"
(W 13.0 x D 19.1 x H 25.4 cm)

Net weight: 10.62 lb (4.8 kg)

Air input required: 60 psi (4.14 bar) minimum

Tank air pressure regulator:
30 psi (2.07 bar) maximum

Nozzle air regulator: 30 psi (2.07 bar) maximum

Cycle rate: Up to 60 per minute

Pressure switch rating: 20VA 240V

MicroCoat® Tank Reservoirs

Operating pressure: 30 psi (2.07 bar) maximum

Safety relief pressure: 40 psi (2.76 bar)

Low level switch rating: 20VA 240V

MC685

Capacity: 1 gallon (3.8 L)

Construction: Acrylic tank wall
Anodized aluminum end caps

Net weight: 9.18 lb (4.1 kg)

MC686

Capacity: 2 gallon (7.5 L)

Construction: Acrylic tank wall
Anodized aluminum end caps

Net weight: 11.6 lb (5.2 kg)

MC687, MC687-DFS

Capacity: 5 gallon (19 L)

Construction: Type 304 stainless steel

MC687-DFS: Includes two float switches:
mid-level warning indicator, and
low level indicator for press shutdown.

Net weight: 17.54 lb (7.9 kg)

How the System Operates

The MicroCoat® System incorporates up to four low volume low pressure (LVLP) spray valves; a lubricant reservoir; and a controller that regulates air pressure, meters lubricant flow and controls valve operation.

Constant air pressure applied to the tank reservoir forces lubricant through precision fluid flow controls inside the MC4000 controller, then out to the spray valves.

When the press is stamping, a 3-way air solenoid activates the system and opens the valves. As the valve opens, LVLP air creates a pressure drop at the nozzle, causing the lubricant to spray in a fine film onto the stock.

Lubricant flow can be adjusted independently for each valve via flow controls on the front of the MC4000 controller.

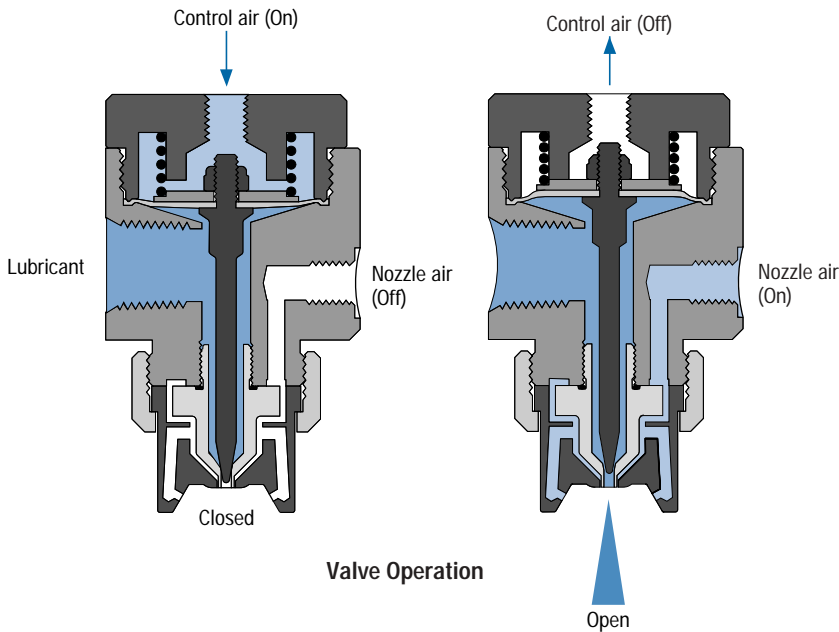

Controller Features

1. System Pressure Switch

Turns the system air supply on and off.

2. Mode Switch

Use Manual/Setup position to prime and test the valves without running the press.

In the Auto/Run position, the system will spray lubricant when the press begins stamping.

Press air solenoid must be properly installed to allow the MicroCoat® System to run in Auto/Run mode (refer to page 11).

3. Tank Air Pressure

Regulates air pressure in the lubricant reservoir. For most lubricants, 15 psi (1.03 bar) is a good start.

Minimum setting is 12 psi (0.83 bar).

4. Nozzle Air

Regulates nozzle air pressure.

Average setting is 8 to 12 psi (0.55 to 0.83 bar). Higher pressure provides finer spray.

5. Flow Controls

Provide independent flow control of the lubricant to each spray valve. Each yellow ring on the stem coming out of the middle of the knob indicates one complete revolution.

Turn counterclockwise to increase flow.

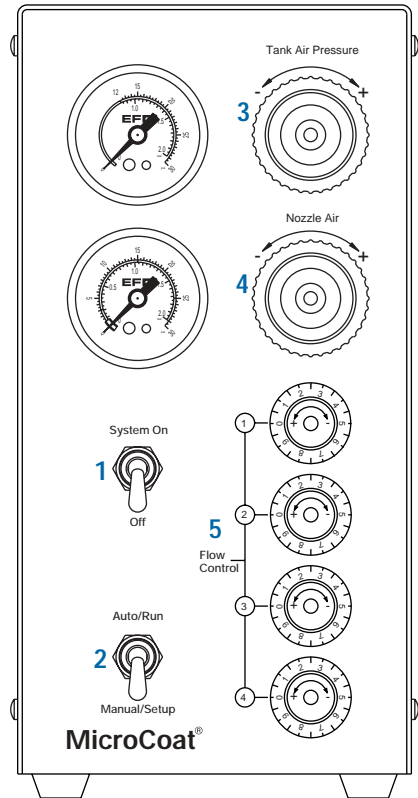

MC4000 Front View

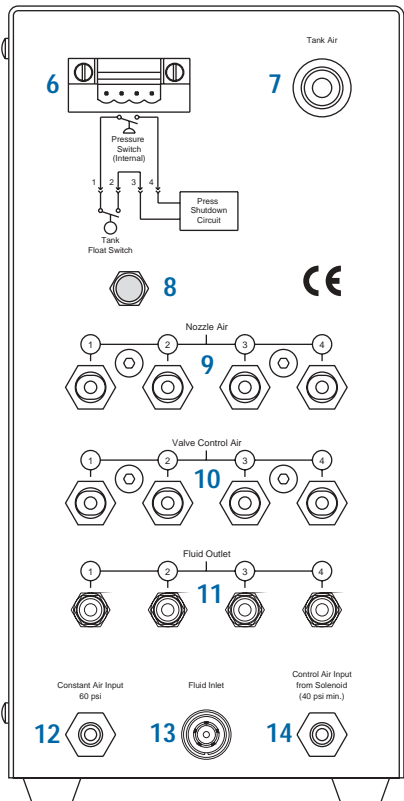

MC4000 Rear View

6. Four-pin Connector

Connects the tank low level switch cable to the controller.

Must be wired to the press Emergency Stop Circuit to prevent the press from operating without lubricant (refer to pages 14-15).

7. Tank Air

Air from this port pressurizes the lubricant reservoir.

8. Exhaust Muffler

9. Nozzle Air

Air from these ports is used to spray the lubricant.

10. Valve Control Air

Air from these ports controls the opening and closing of the spray valves.

11. Fluid Outlet

Pressurized lubricant flows from these ports to the spray valves.

12. Constant Air Input

The main air supply to the system should be a minimum of 60 psi (4.14 bar).

13. Fluid Inlet

Lubricant from the tank reservoir enters the controller through this port.

14. Control Air Input from Solenoid

Activates the system when the press begins stamping. Minimum 60 psi (4.14 bar) required.

Tank Reservoir Features

1. Low Level Switch

Prevents the system from operating without lubricant when connected to the press Emergency Stop Circuit. Switch opens when tank level is near empty.

2. Air Pressure Relief Valve

Automatically exhausts air if tank reservoir pressure exceeds 40 psi (2.76 bar).

Also used to manually exhaust air pressure before refilling the tank.

3. Fill Port Cap

Ported threads relieve any residual reservoir air pressure when cap is loosened.

4. Drain Plug

5. Lubricant Inline Filter

6. Bleed Valve

Valve releases air after filter replacement.

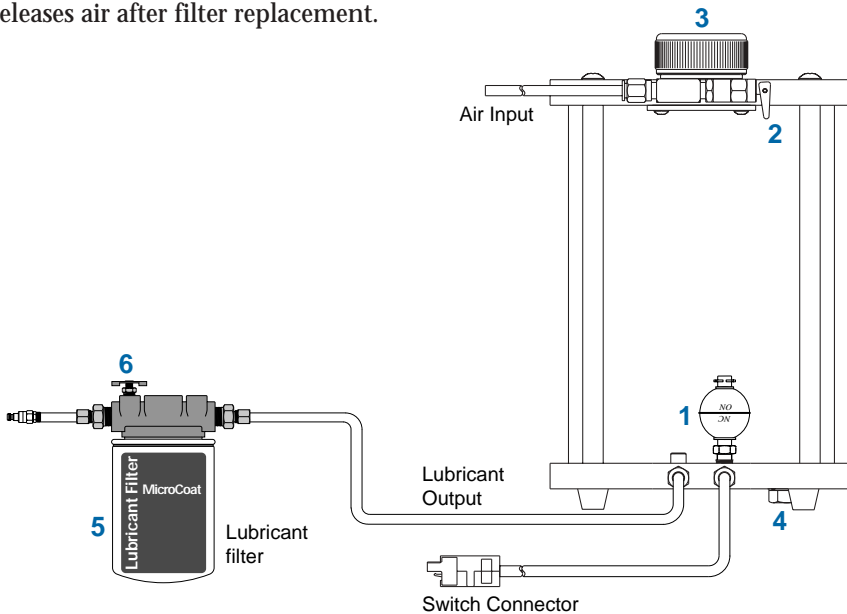

System Assembly

Step 1: Mount the Spray Valves

Mount each valve with the mounting clamp (#78525) provided, or use the M6 mounting hole in the valve body to attach the valve to an alternative mounting bracket.

Note: Optional valve mounting fixtures provide easy installation of the valves without the need to drill or fabricate attachment hardware. See page 23 for further information.

To ensure proper lubrication coverage, mount the MC785M valve so the tabs on the air cap are in line with the stock as illustrated. Use the valve alignment tool (#MC7326) shown on page 23 for precise valve alignment.

IMPORTANT: If you loosen the air cap retainer nut to reposition the tabs, be sure to retighten the nut with a wrench before operating the valve.

The width of spray coverage is determined by the distance between the valve nozzle and the stock, as shown in the chart below.

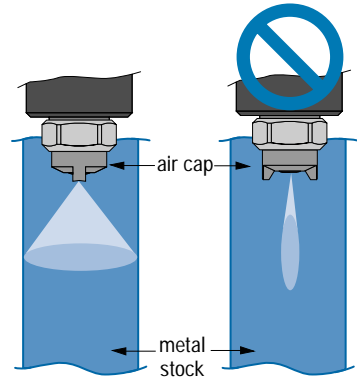

Proper air cap alignment

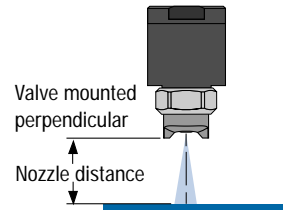

Valve mounted perpendicular
 Nozzle distance

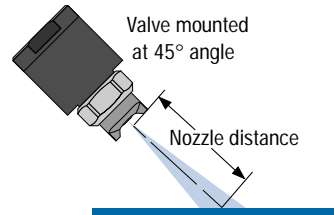

Valve mounted at 45° angle
 Nozzle distance

Spray Area Coverage

Nozzle distance to stock

	1.00" 25.4 mm	2.00" 50.8 mm	3.00" 76.2 mm	4.00" 101.6 mm	5.00" 127.0 mm	6.00" 152.4 mm
MC785M	1.00" 25.4 mm	1.50" 38.1 mm	2.00" 50.8 mm	2.50" 63.5 mm	2.75" 69.9 mm	3.25" 82.6 mm
MC785M-WF	1.50" 38.1 mm	2.50" 63.5 mm	3.50" 88.9 mm	4.50" 114.3 mm	5.50" 139.7 mm	6.50" 165.1 mm

The MC785M-WF is recommended for spray widths from 2.0" to 6.0".

Note: Spray width coverage may vary depending on the viscosity and surface tension of the fluid.

Step 2: Set Up the Controller

First, place the controller and tank reservoir away from traffic areas and position the tank to allow for convenient refilling.

The controller requires two 60 psi (4.14 bar) filtered, dry air inputs:

- a. Constant air
- b. Control air from a 3-way solenoid

Refer to diagram on page 11.

1. Set the controller System Pressure switch to the Off position and the mode switch to the Auto/Run position.
2. Connect the five-micron filter regulator to the plant air supply.
3. Using the two black air hoses provided with the system, connect the air hose quick-connects to the Constant Air Input and Control Air Input from Solenoid fittings at the back of the controller.

Step 3: Connect the Press Air Solenoid

To provide proper air distribution and control, a press air solenoid (available separately) must be connected to the MicroCoat® control air input.

1. Select the appropriate 3-way solenoid. Flow must meet or exceed 2.0 cfm (.06 cu. m.) at 60 psi (4.14 bar).
2. Cut the control air hose at a convenient location and install the solenoid as shown.
3. Connect the solenoid wires to the press control circuit.

Note: When the press is stamping, the solenoid allows control air into the MicroCoat® System. When the press is idle, the solenoid shuts off the air pressure and prevents the MicroCoat® System from operating.

Press Air Solenoid Diagram

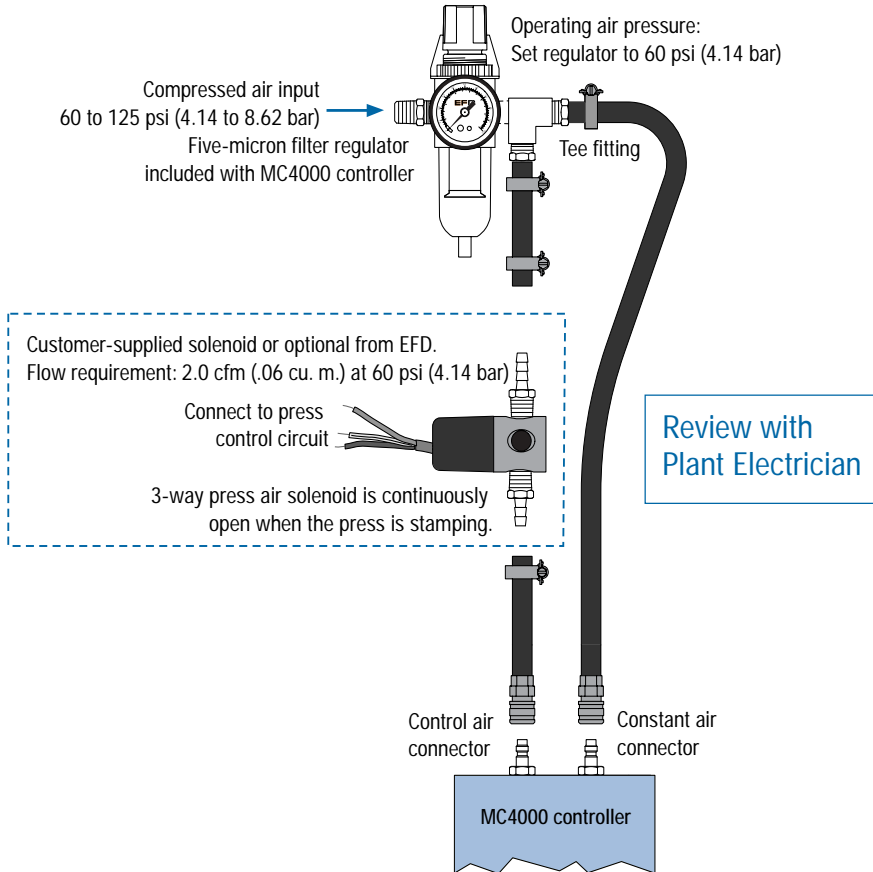

EFD MicroCoat Solenoids

Part Number	Description
2003MC-24DC	24 volt DC solenoid
2003MC-24AC	24 volt AC solenoid
2003MC-100	100 volt AC solenoid
2003MC-120	120 volt AC solenoid
2003MC-220	220 volt AC solenoid

EFD MicroCoat Solenoid Cord Sets

Part Number	Description
2009MC	AC solenoid cord set
2009MC-24DC	DC solenoid cord set

Step 4: Connect the Valve Hoses

Each valve is supplied with a tri-hose assembly and a series of numbered tags. The numbered tags are used to ensure that each valve is connected to the corresponding outlets on the back of the controller.

Connect each valve as follows:

1. First note each valve's position and then assign numbers by valve location. Place the corresponding number tag on both ends of the tubing jacket.
2. Connect the clear fluid hose into the appropriate Fluid Outlet connector on the back of the controller.
3. Connect the black air hose to the corresponding black Nozzle Air connector on the back of the controller.
4. Connect the white air hose to the corresponding white Valve Control Air connector on the back of the controller.
5. Repeat the above for the remaining valves.

Step 5: Connect the Tank Reservoir and Lubricant Filter

The tank reservoir is supplied with a lubricant filter, fluid hose, air hose and low level switch cable.

Connect the tank to the controller as follows:

1. Connect the grey air hose to the Tank Air fitting on the back of the controller. Connect the opposite end of the hose to the Tank Air Inlet fitting on top of the tank.
2. Mount the filter adapter to the tank reservoir or MicroCoat stand using the hardware provided.
3. Connect the clear fluid hose to the Fluid Inlet connector on the back of the controller. Then connect the opposite end of the fluid hose to the outlet fitting at the bottom of the tank reservoir.
4. Cut the clear fluid hose from the tank to the controller so the end of the hose coming from the tank can be installed into the "IN" port of the filter adapter.
5. Connect the fluid hose from the controller to the "OUT" port on the filter adapter.
6. Lubricate the filter gasket and screw the filter onto the adapter until the gasket makes contact and then tighten an additional 3/4 turn.
7. Refer to pages 14 and 15 to wire the press Emergency Stop Circuit and to connect the low level switch cable to the controller.

System Diagram

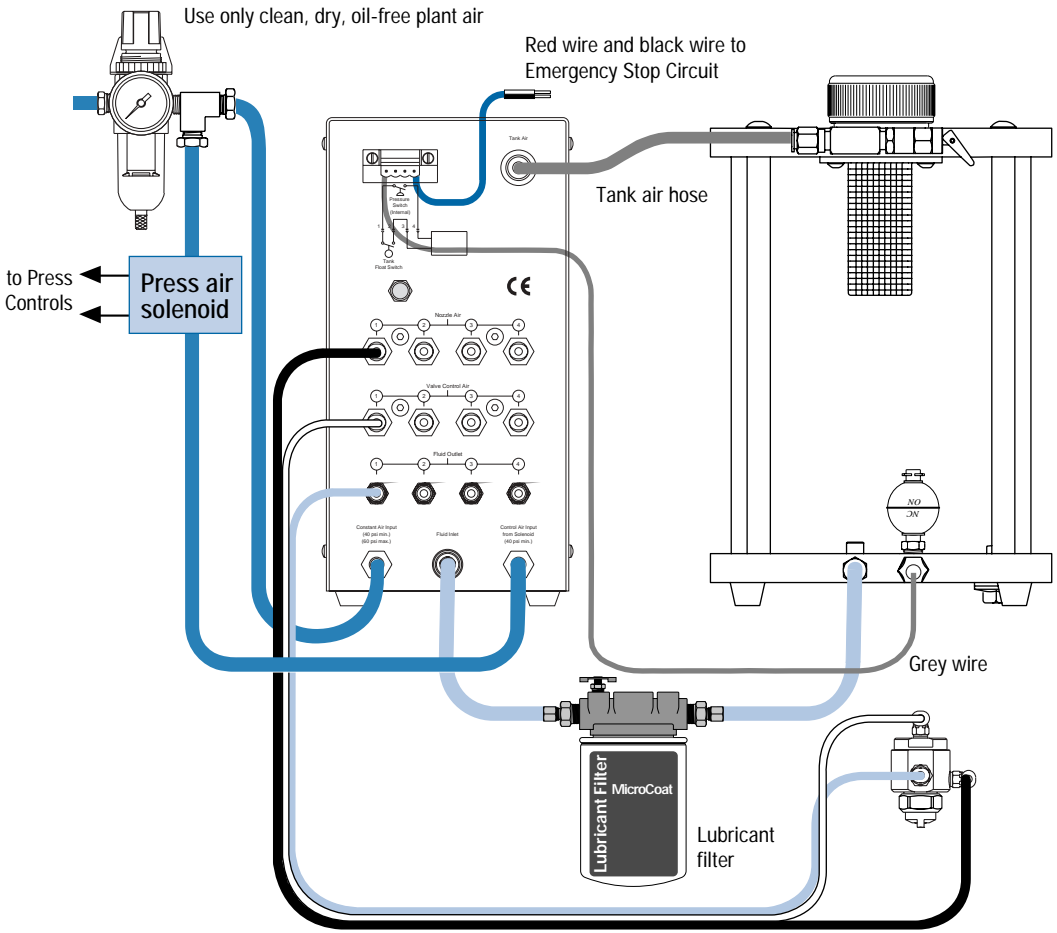

- Lubricant (clear hose)
- Nozzle air (black hose)
- Control air (white hose)
- Operating air

Note: Replace filter element (part #4000FLT) every 6 months or 1000 hours of operation.

Dispose of used filters in accordance with local environmental regulations.

Step 6: Connect the Emergency Stop Circuit

The Emergency Stop Circuit on the press must be properly wired to the MicroCoat® System to prevent the press from stamping without lubricant and to alert the operator if the tank air pressure drops below 10 psi (0.69 bar).

The two safety switches—the low level switch and the low pressure switch—are already wired in series with each other.

These switches must also be wired in series with the Emergency Stop Circuit from the press.

1. Connect the red and black wire to the Emergency Stop Circuit located on the press.
2. Plug the low level switch cable connector into the rear panel of the MicroCoat® controller.

Review with
Plant Electrician

Emergency Stop Circuit Diagram

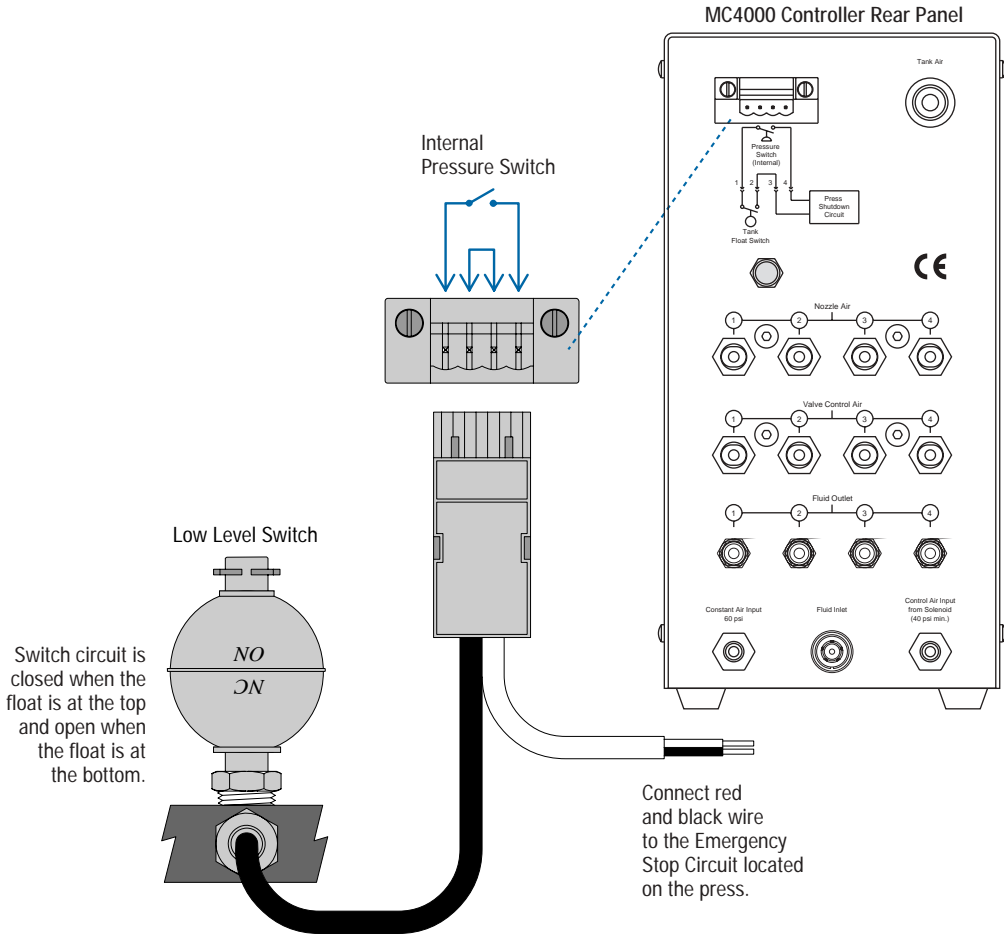

Pressure switch and low level switch ratings: 20VA 240V

System Setup

Check All Connections

1. Check that all connections are correct and secure.
2. Verify that the System Pressure switch is set to the Off position and the mode switch is set to the Auto/Run position.
3. Check that the input air supply is connected and set at 60 psi (4.14 bar).

Fill the Tank Reservoir

1. Unscrew the tank cap and fill the tank reservoir with lubricant to the level indicated on the tank label.

Note: Do not overfill. Overfilling may cause lubricant to flow back into the controller.

2. Reinstall the tank cap.

Prime the System

1. Set the System Pressure switch to On.
2. Adjust the Tank Air Pressure regulator to 15 psi (1.03 bar). Do not set pressure lower than 12 psi (0.83 bar).
3. Turn the Nozzle Air pressure regulator knob counterclockwise as far as it will go to prevent nozzle air from flowing while priming the valves.
Note: Regulator knobs have a push to-lock, pull-to-unlock feature.
4. Turn all four Flow Control knobs completely clockwise until closed.
5. Set the mode switch to Manual/Setup.
6. Open the valve on the filter adapter until all the air is removed.

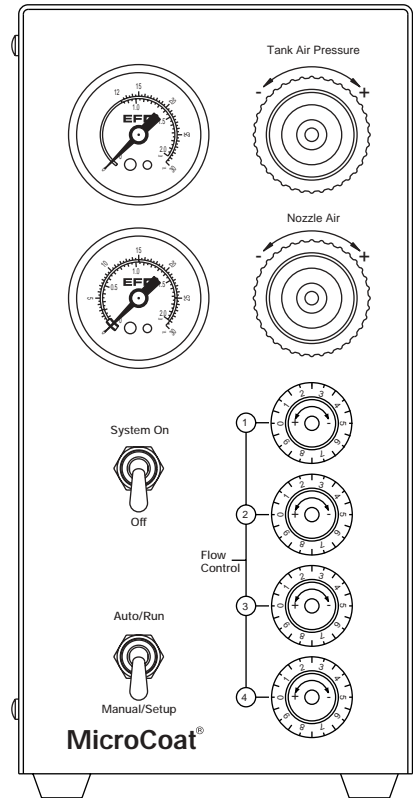

7. Check for leaks around the filter and all connections between the tank and controller.
8. Select one valve and open the appropriate Flow Control knob about five full turns (counterclockwise) to fill the hose and prime the valve.
9. When the lubricant flows in a steady stream, the valve is primed. Close the Flow Control (turn clockwise).
10. Repeat steps 8 and 9 for each valve.

IMPORTANT: Each valve must be fully primed (lubricant flows in a steady stream) before adjusting the spray.

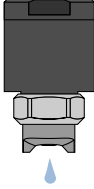

After priming the valve, adjust lubricant flow to a rate of approximately one drop per second.

Adjust the Spray

1. As a starting point, select one valve and adjust the Flow Control knob so that lubricant flows from the valve at the rate of approximately one drop per second.
2. Note the number set on the graduated dial of the open Flow Control. Set the flow for each remaining valve to the same setting.
3. Turn the Nozzle Air regulator clockwise until pressure reads between 8 to 10 psi (0.55 to 0.69 bar) and the valve begins to spray. Thicker lubricants may require 12 to 15 psi (0.83 to 1.03 bar). Push the knob in to lock.
4. Set the mode switch to Auto/Run. The spray will shut off. The valves are ready to spray when the press is stamping.
5. After starting the press, adjust the Flow Control knobs as needed to provide proper lubricant coverage.

Preventive Maintenance

The MicroCoat® System is designed for long life with minimal maintenance. To ensure trouble-free performance, follow these precautions and preventive maintenance steps:

1. Always use clean lubricant.
2. Check for residue at the bottom of the tank reservoir and clean if necessary.
3. Do not clean the MC685 or the MC686 tank with chlorinated solvents, aromatic hydrocarbons or any fluid that will attack acrylics. Use only soap and water or mineral spirits to clean acrylic tank surfaces.
4. Operate the system with clean dry, oil-free air. Drain the bowl on the five-micron filter regulator whenever moisture or oil is present.
5. Replace lubricant filter (Part #4000FLT) every 6 months or 1000 hours of operation.

CAUTION: Before performing any maintenance, set the **System Pressure Switch** to the **Off** position and depressurize the tank reservoir by lifting the lever on the tank pressure relief valve.

Spray Valve Maintenance

CAUTION: Before performing any maintenance, set the System Pressure Switch to the Off position and depressurize the tank reservoir by lifting the lever on the tank pressure relief valve.

When using filtered plant air and clean lubricants, the MC785M series spray valves are designed for long term performance without scheduled maintenance.

If lubricant flow stops or becomes erratic, first review Troubleshooting on page 22. Cleaning the nozzle will solve most problems related to lubricant flow and spray patterns.

To Clean the Nozzle

Remove the air cap retainer nut, air cap and nozzle from the outlet end of the valve. Clean and reinstall, as illustrated on page 9.

Valve Disassembly

Note: Install a new diaphragm (#78527) each time the valve is reassembled.

1. Remove air cap retainer nut, air cap and nozzle from the outlet end of valve.
2. Remove diaphragm chamber cap, diaphragm return spring and needle/diaphragm assembly from the valve body.
3. Remove diaphragm retaining nut and spring locating washer from the needle, then remove and discard old diaphragm.
4. Clean all parts in mineral spirits.

Valve Reassembly

1. Place the new diaphragm over the threaded end of the needle. The black Viton® side of the diaphragm should face the threaded end. The blue-grey Teflon® side should face the wetted side of the valve. Note illustration.
2. Place the spring locating washer over threaded end of the needle. The stepped side should face the threaded end.
3. Install a new diaphragm retaining nut (included with #78527 diaphragm) and turn it until the nut starts to feel tight and the diaphragm can not be rotated on the needle with fingers. Avoid crushing the diaphragm causing it to bulge away from the washer.
4. Install the needle/diaphragm assembly into the valve body, then install diaphragm return spring and diaphragm chamber cap, and tighten firmly.
5. Reinstall the nozzle, air cap and air cap retainer, as illustrated on page 9.

The air cap retainer nut should be tightened with a wrench to prevent loosening due to press vibration.

MC785M Series Spray Valve and Part Numbers

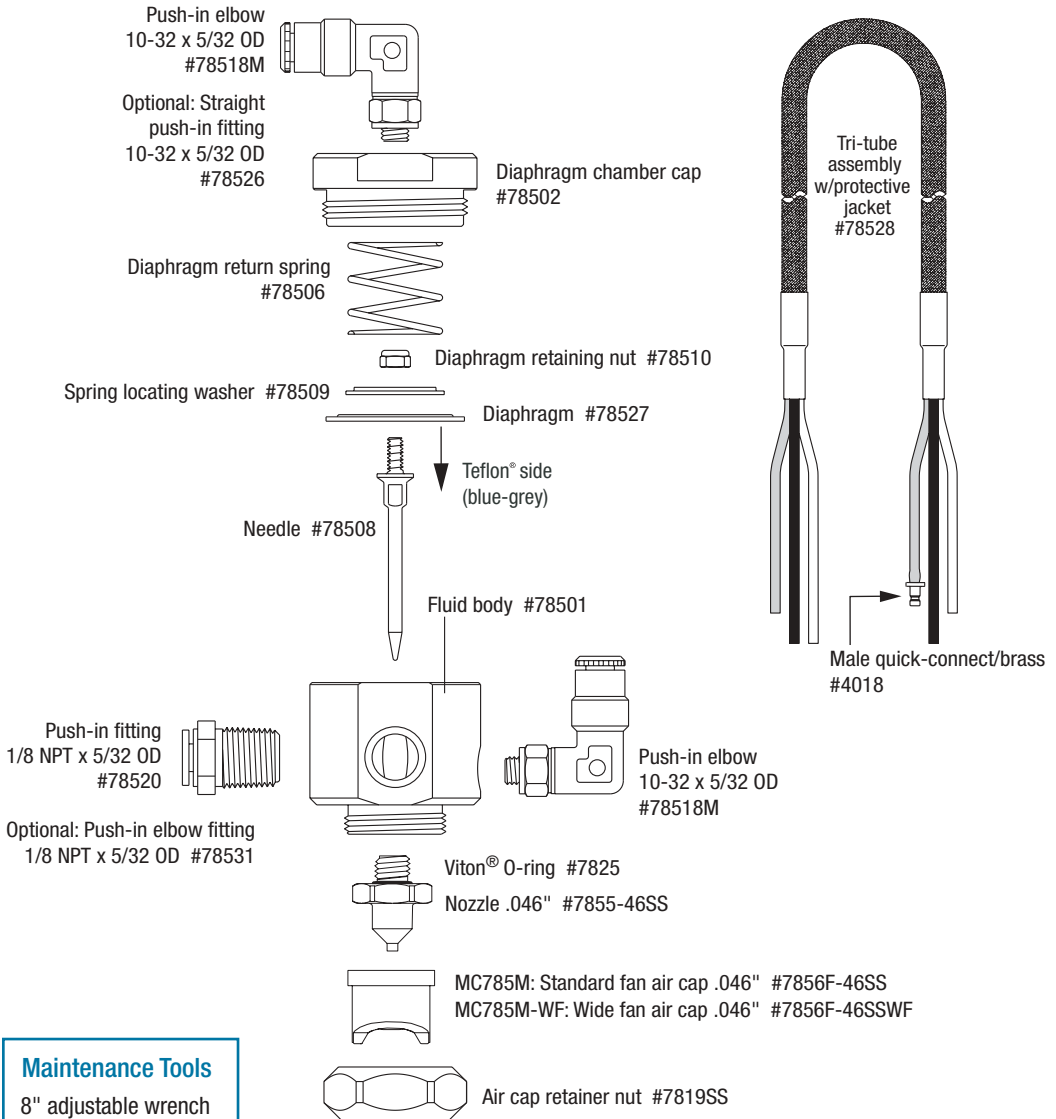

Maintenance Tools

8" adjustable wrench
 7/8" open end wrench
 5/16" box end wrench
 1/4" nut driver

Controller Air Schematic

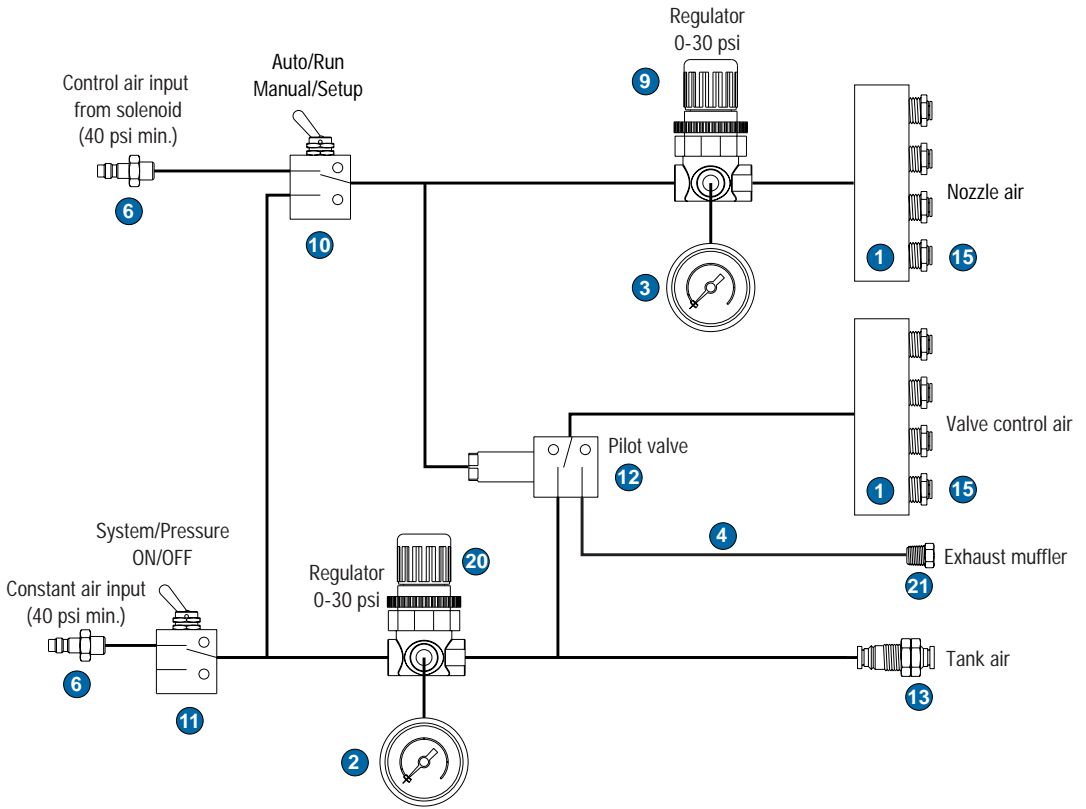

Oil Flow Schematic

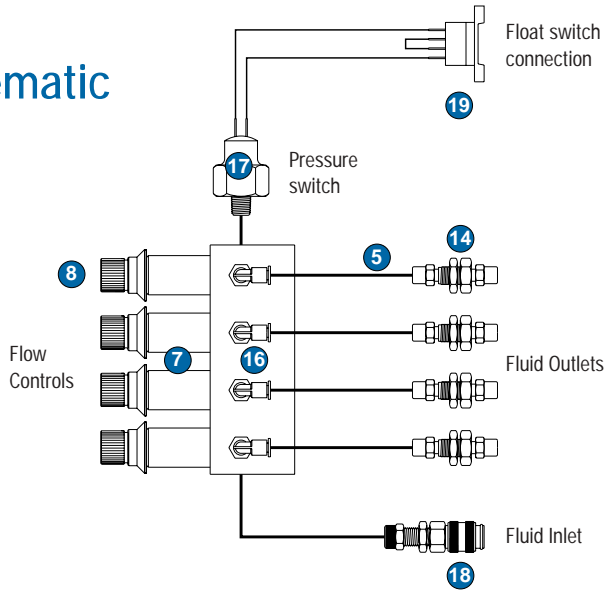

Controller and Tank Replacement Part Numbers

Controller (Refer to schematic on page 20.)

1. 4010	4-port manifold	11. 4044A	Selector switch assembly for System Pressure
2. 2001MC	Tank air pressure gauge 0 to 30 psi (0 to 2.07 bar)	12. 4045	Air pilot valve assembly
3. 2001MCA	Nozzle air pressure gauge 0 to 30 psi (0 to 2.07 bar)	13. 4015	Female air output fitting to tank
4. 2024-6MM	6 mm OD tubing	14. 4039	Female fluid outlet fitting
5. 2024LG	5/32" OD x 3/32" ID tubing	15. 4025	Female air output fitting to valves
6. 2081A	Male air input fitting	16. 4028	Flow control manifold
7. 8176MC	Flow control	17. 4029	Low fluid pressure switch
8. 8176-KNOB	Flow control dial and knob	18. 4030	Female fluid inlet fitting
9. 2-2002F-MCN	Regulator assembly for nozzle air	19. 7114D	4 pin female connector
10. 4044B	Selector switch assembly for Manual/Auto		

One and Two Gallon Tank Reservoir

2024G	Grey urethane connecting air hose
68519	Viton® O-ring for filler cap
68506	(2) Neoprene gaskets for acrylic tube
68509	Pressure relief valve 40 psi (2.76 bar)
2184	Push-in fitting, tank inlet
68503	Acrylic tube 6.50" D x 8.96" L (One gallon)
68514	Acrylic tube 6.50" D x 16.35" L (Two gallon)
73511	1/8" NPT x 1/4" compression fitting, tank outlet
68516	Stainless steel tank fill screen
4020	Tank-to-controller male quick-connect
2025	1/4" OD x 1/8" ID tubing, polyethylene
68517	Filler cap
68502KIT	Tank top, filler cap and screen
68511	Nickel-plated brass drain plug
68507	Stainless steel float switch kit (includes connector, wiring & strain reliefs)
7114C	4 pin male connector
MCFILTER	Lubricant filter kit
4000FLT	Lubricant filter element (4) per box

Five Gallon Tank Reservoir

600D3-AV	Viton® O-ring for tank cover
2004C	Female air quick-connect
687FS	Float switch assembly
687DFS	Double float switch assembly
2025	1/4" OD x 1/8" ID tubing, polyethylene
4020	Male quick-connect to MC4000 fluid inlet
2024G	1/4" OD x 1/8" ID air hose, urethane
7114C	4 pin male connector
MCFILTER	Lubricant filter kit
4000FLT	Lubricant filter element (4) per box

Troubleshooting Guide

MC4000 Controller

Possible cause and correction

Air pressure regulator will not maintain set pressure.

Contaminated air supply. Remove the controller cover to access the regulator. Remove the brass hex plug, spring and poppet from the regulator. Clean poppet and reinstall the poppet, spring and plug.

No lubricant flow to valve.

Tank pressure may be too low. Minimum operating tank air pressure is 12 psi (0.83 bar).

Hose connector may not be pushed fully into the fluid outlet fitting on the rear panel of the controller. Ensure connector is firmly seated.

Check fluid hose for kinks.

MC785M Spray Valve

Possible cause and correction

Lubricant flows but valve does not spray.

Air cap may be clogged. Be sure oil tank filter is clean. Remove air cap and clean the inside of the air cap and the outside of the nozzle. Refer to Valve Maintenance on page 18.

Nozzle air pressure regulator may be set too low. Increase pressure as needed. Normal working range is within 8 to 15 psi (0.55 to 1.03 bar).

Valve drips after shutdown.

Dripping can be caused by improper seating of the needle in the nozzle. Clean the needle and nozzle, and replace any worn or damaged parts.

Ensure nozzle is tight to seat the needle properly.

.....
If trouble cannot be corrected, or if you need further assistance, **please call us**. In the U.S., call **800-498-8865**. In the U.K., ring free 0800 585733. In Mexico, 001-800-556-3484.

Accessories

Valve Mounting Clamp

#78532M: Use to mount MC785M series valve or to secure mounting rod on press. Included with each MC785M and MC785M-WF valve.

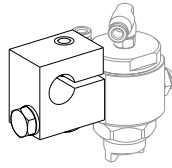

Cross Clamp

#MC7321: Used to extend valves from expansion or gantry mount.

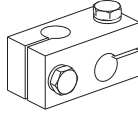

Control Panel Shield with Lock

#MCSHIELD: Prevents unauthorized adjustment of flow controls. Mounts directly onto MC4000 Controller. Clear Lexan™ cover with key lock.

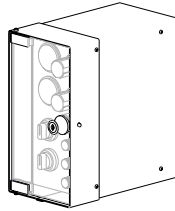

Expansion Mount

#MC7325: Fits in the press window of four post stamping presses. Includes (2) sets of 1/2" diameter stainless steel rods and mounting hardware. Works with press windows up to 12".

#MC7325-24: Works with press windows up to 24".

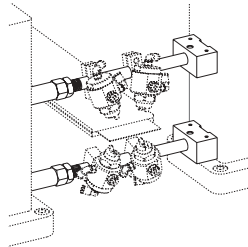

Stand

#MC7300: Adjustable aluminum stand. Comes complete with all items necessary for stable mounting of reservoir and controller. Height 43". Width 20".

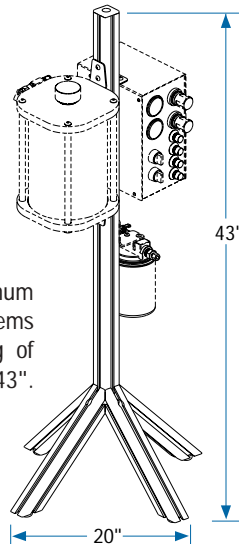

Mounting Brackets

#MC7301: For mounting controller to MC7300 stand or press enclosure. Included with each MC4000 controller.

#MC7302: For mounting MC685 tank to MC7300 stand or press enclosure.

Included with each MC685 or MC686 tank.

Mounting Rod

#7312: Stainless steel rod 1/2" diameter x 10" long.

Extension Rod

#MC7327: Use with cross clamp to extend valves beyond press window. Rod is 1/2" diameter x 4" long.



Gantry Mount

#MC7328: For installing on bolster plate or other flat area. Includes (4) MC7321 cross clamps, (2) 9.4" threaded vertical rods, (2) 15.75" horizontal rods and (1) 13.75" base plate.

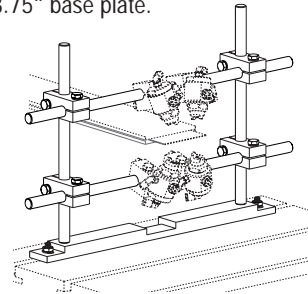

Valve Alignment Tool

#MC7326: Use to position the valve to provide exact spray coverage. Includes (3) standard and (3) wide fan templates.

