

# Operating Guide

## 900 Series Dispenser

900 • 900-15 • 900-CA

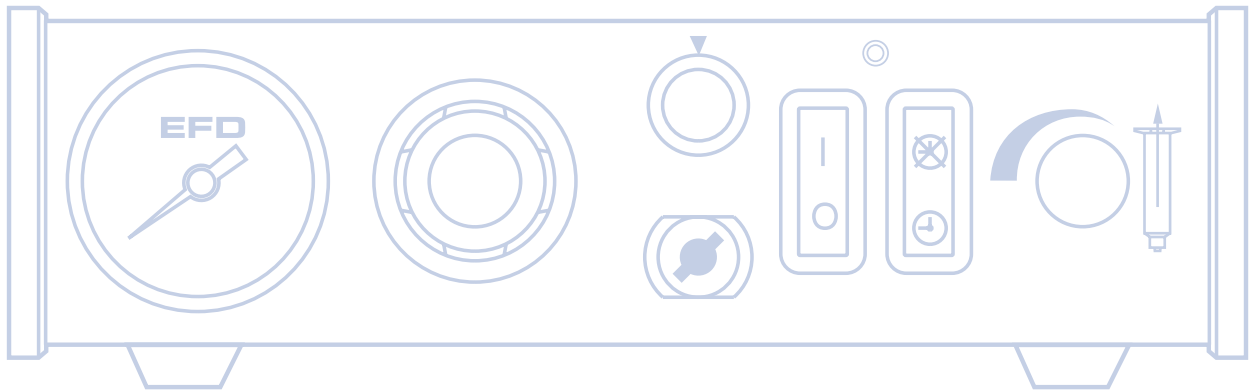

# Introduction

The 900 Series fluid dispensers provide years of trouble-free, productive service. This Operating Guide will help you maximize the usefulness of your new dispenser.

Please spend a few minutes to become familiar with the controls and features of your new dispenser. Follow our recommended testing procedures. Review the helpful information we have included based on over 30 years of industrial dispensing experience.

Most questions you will have are answered in this Guide. However, if you need assistance, please do not hesitate to contact EFD or your authorized EFD distributor.



**In the US, call 800-556-3484.**

In Mexico, call 001-800-556-3484.

In the UK, ring free 0800 585733.

## The EFD Pledge

We pledge that you will be completely satisfied with our products. We endeavor to ensure that every EFD product is produced to our no-compromise quality standards.

If you feel that you are not receiving all the support you require, or if you have any questions or comments, I invite you to write or call me personally.

Our goal is to build not only the finest equipment and components, but also to build long-term customer relationships founded on superb quality, service, value and trust.

Randall Richardson, President

### Specifications

Input voltage: Selectable  
100/120/220 VAC 50/60Hz 26/20 VA  
Internal voltage: 24 VDC  
Foot pedal voltage: 9 VDC  
Air input: 80 to 100 psi (5.5 to 6.9 bar)  
Air output: (900)  
0 to 100 psi (0 to 6.9 bar)  
Air output: (900-15, 900-CA)  
0 to 15 psi (0 to 1.0 bar)  
Cycle rate: >600/minute  
Time repeat:  $\pm 0.1\%$   
Time ranges: programmable (seconds)  
0.005 to 0.04 sec.  
0.01 to 1.0 sec.  
0.1 to 10 sec.  
0.2 to 20 sec.  
0.3 to 31 sec.

#### 900, 900-15, 900-CA

8 $\frac{3}{8}$  x 8 $\frac{1}{2}$  x 2 $\frac{3}{8}$ " 4 lb 2 oz  
(21.9 x 21.6 x 6.7 cm) (1.87 kg)

# First Steps

## Contents

Hookup .....	4-5
Setup for Testing .....	6-7
Testing the Dispensers .....	8-9
Making Timed Deposits of Medium to Thick Fluids	
Changing Deposit Size and Drawing Stripes	
Programmable Timer .....	9
How to Use the Vacuum Control .....	10-11
Making Timed Deposits of Watery-thin Fluids	
ULTRA Dispensing System .....	12-13
Loading the Barrel Reservoirs .....	14-15
Schematic & Parts .....	16
Troubleshooting .....	17
Suggestions & Reminders .....	18
Reordering Components .....	19
Two Year Limited Warranty .....	20

*Meets applicable CSA and CE requirements.*

Reference CSA LR File Number 84105

This manual is for the express and sole use of EFD dispenser purchasers and users, and no portion of this manual may be reproduced in any form. EFD, ULTRA System, LV Barrier, SmoothFlow, ZeroDraft, SafetyLok, SnapLok and DispenStand are trademarks of EFD Inc. ©2002 EFD Inc.

First: Unpack and use the checklist enclosed with the Dispenser Kit to identify all items. If there is any discrepancy, please call us immediately.

Second: Power and compressed plant air should be available where the dispenser is to be set up. Air pressure should be between 80 and 100 psi (5.5 and 6.9 bar). If you are not using an EFD five-micron filter regulator #2000F755, **be certain your plant air is properly filtered and dry and a regulated, constant air pressure is supplied to the dispenser.**

**Note:** Model 900-CA is supplied with an EFD five-micron filter regulator with coalescing filter (#2000F756).

**Bottled nitrogen can be used.**

**Warning:** If high pressure bottled air or nitrogen is used, a high pressure regulator must be installed on the bottle and set at 100 psi maximum. The 2000F755 filter regulator is not recommended.

**Check the voltage label to be certain it is set to the available power.**

Third: Now is a good time to **ACTIVATE** your extended **Two Year Limited Warranty**. Please fill in and return the postage paid Warranty card. Or if you prefer, call the appropriate toll-free number listed below, provide the serial number of your dispenser and respond to a few short questions. You are then assured of complete protection for two years.



**In the US, call 800-556-3484.**

In Mexico, call 001-800-556-3484.

In the UK, ring free 0800 585733.

**Note:** For hookup purposes, connections for the 900, 900-15 and 900-CA models are identical.

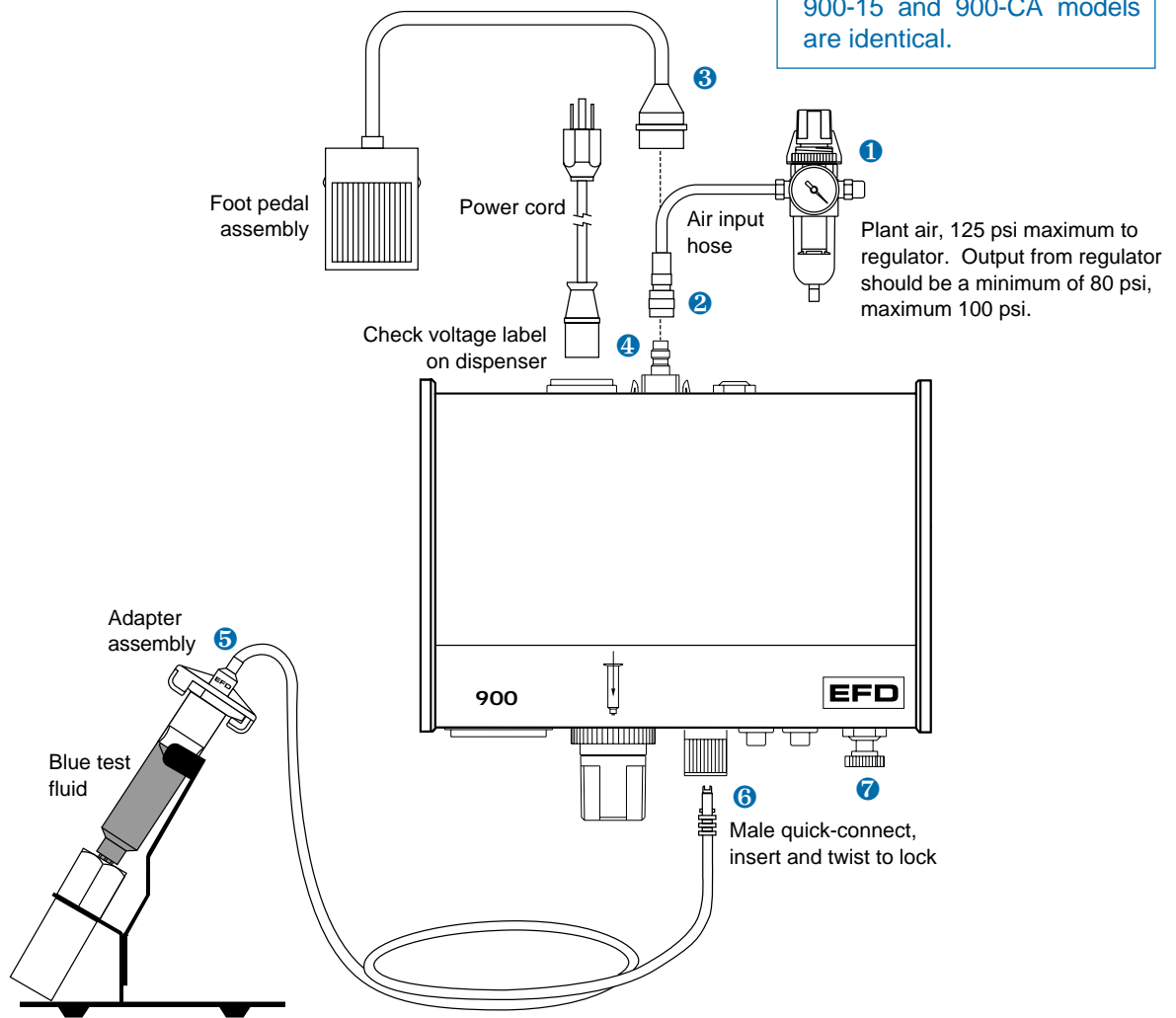

# Hookup

- 1 Connect the air input hose to a plant air source. Set plant air supply within 80 to 100 psi (5.5 to 6.9 bar). Where required, use an EFD five-micron filter regulator #2000F755 (see Warranty).
- 2 Attach the air input hose coupling to the dispenser. Pull back metal ring to attach to dispenser.
- 3 Plug in the polarized foot pedal connector.
- 4 Check the voltage label on the input voltage selector cartridge. To change the voltage, remove the voltage selector from the cartridge, rotate it and position the correct voltage to show through the cartridge window. Replace the cartridge into the power cord receptacle and insure that both sides snap securely into position. Install the power cord.

**Note:** For 900-15 and 900-CA dispensers, use the test barrel filled with clear fluid and the red 25 gage tip. Refer to “Making Timed Deposits of Watery-thin Fluids” on page 10.

- 5 Attach the 10cc barrel pre-filled with blue, nontoxic test fluid (included with the dispenser) to the 10cc adapter head.

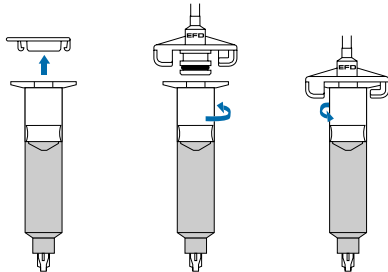

- 6 Take the 10cc barrel adapter assembly (#5150 on the adapter head) and insert the black, male quick-connect into the air output fitting on the front panel and turn clockwise to lock. Place the barrel in the barrel stand.
- 7 During the initial testing, you will not use the vacuum control. Keep this control shut off (turned completely clockwise—do not force).

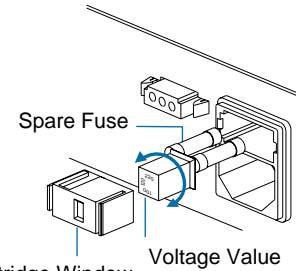

Cartridge Window  
(check voltage indicated)

**Note:** The dispenser is shipped with the fuse cartridge set for 120 VAC input.

# Controls & Connections

**Note:** The controls for the 900, 900-15 and 900-CA dispenser models are identical.

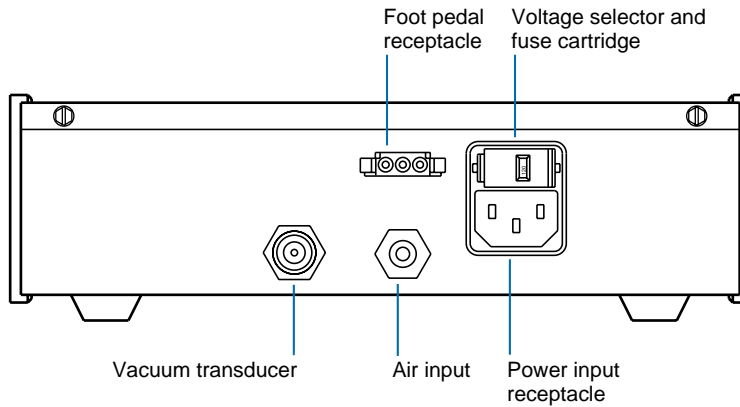
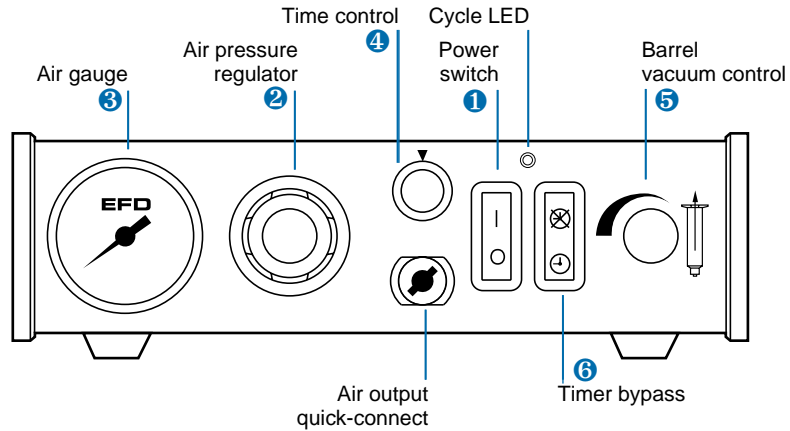

# Setup for Testing

Power switch ❶ should be off.

The amount of material dispensed each cycle depends on the combination of air pressure, time of air pulse, viscosity of material and dispensing tip size.

**Note:** The following steps refer to the 900 dispenser. For the 900-15 and 900-CA dispensers, refer to “Making Timed Deposits of Watery-thin Fluids” on page 10.

The first step is to remove the tip cap from the pre-filled barrel of blue test material (twist and pull). Replace it with an 18 gage (green) tapered dispensing tip. Press the tip on and twist clockwise to lock.

Pull out air pressure regulator knob ❷ until it “clicks” into the unlocked position. Turn clockwise to adjust the air pressure to 30 psi (2.1 bar) for the initial tests .

Always set the pressure desired by turning the air regulator knob ❷ clockwise. To reduce the pressure, turn the knob counterclockwise until the gauge ❸ reads a lower pressure than desired. Then increase and stop at desired pressure. Push knob in to lock.

Set time control ❹ to #7. Dispense cycle time increases from 0.01 second minimum to 1.0 second as knob is turned clockwise.

Be sure vacuum control ❺ is turned off (turn clockwise) for initial tests.

Press power switch ❶ to turn on the dispenser. It will light green.

Press timer bypass switch ❻. It will light yellow. In this operation mode, the timer will be bypassed to fill the dispensing tip before you begin testing. A continuous flow of material will occur as long as the foot pedal is pressed.

Please continue to page 8 for test procedures.

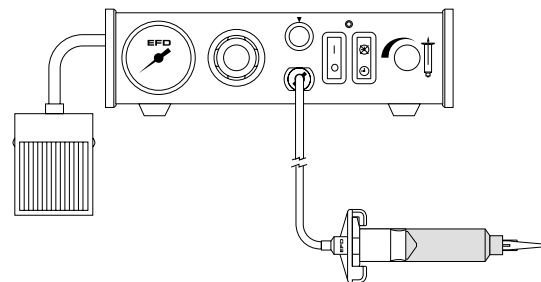

# Testing the Dispensers

## Making Timed Deposits of Medium to Thick Fluids (Model 900)

You are now ready to test the pre-filled, nontoxic, blue test fluid. This material is representative of thick, non-leveling fluids like sealants, pastes or greases.

Check your initial settings:

- A) Air gauge reads 30 psi.
- B) Timer is set at #7.
- C) Green tapered tip is on the test barrel.
- D) Power and timer bypass switches are on.



Pressure

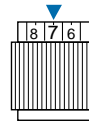

Timer

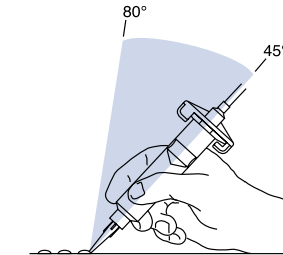

Correct angle for consistent deposits.

Holding the barrel as shown, rest the tip on a piece of paper. Press the foot pedal until the tip fills and some fluid is pushed out onto the paper. Repeat this whenever you change to a new tip.

With the tip filled, turn off the timer bypass switch (yellow light out).

Take the Dot Test sheet and put the tip on a 1/4" circle, holding the barrel as shown. Press the foot pedal. Check the dot size. Make several more similar dots and note the size consistency.

**Remember** – When the yellow timer bypass switch is on, a continuous flow of material will occur as long as the foot pedal is pressed. The yellow light must be off to make timed deposits.

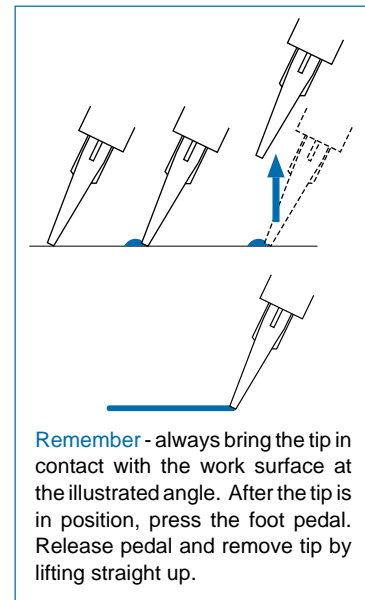

**Remember** - always bring the tip in contact with the work surface at the illustrated angle. After the tip is in position, press the foot pedal. Release pedal and remove tip by lifting straight up.

## Changing Deposit Size, Drawing Stripes

The dot size is determined by the tip diameter, the air pressure output setting and the pulse time. For large dots, use a large tip, higher pressure and more time. Normally, you want to use as short a time pulse as possible. To increase the dot size, slightly increase output air pressure, or increase tip size, or both.

### Dot Test with Green Tapered Tip

First, follow the settings illustrated on the right, and you will get dots about the size shown. Try other times and pressures to see how easy it is to get just the dot size you want.

### Dot Test with Blue Tapered Tip

These tests show the effect of using a smaller diameter tip.

Replace the green tip with the blue (22 gage) tapered tip. Now, turn on the timer bypass switch and press the foot pedal to fill the tip. Then, turn off the timer bypass switch (yellow light out) and press the foot pedal.







To make stripes, press the timer bypass switch (yellow light on). With the tip in contact with the test sheet, press and hold down the foot pedal while making a bead or stripe.

## Programmable Timer





Each 900 series dispenser has a digital timer with programmable time ranges.

The DIP switch that controls the timer has been set at the factory for a time range of 0.01 to 1.0 second, with the initiation set to MOMENTARY contact. If a longer time range is required, or foot pedal operation needs to be changed from momentary to maintained, choose the appropriate dip switch setting in the chart below.

### Green Tip Settings

Test	Pressure	Time	Dot Size
A	30 psi	#7	
B	20 psi	#7	
C	10 psi	#7	
D	20 psi	#3	
E	15 psi	#3	
F	10 psi	#3	

### Blue Tip Settings

Test	Pressure	Time	Dot Size
G	30 psi	#6	
H	20 psi	#6	
I	20 psi	#3	
J	15 psi	#3	
K	10 psi	#3	

## DIP Switch Settings

0.01-1.0 second

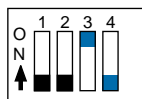

0.1-10 seconds

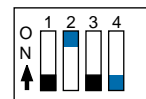

0.2-20 seconds

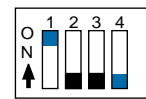

0.3-31 seconds



(4) ON = Maintained pedal contact (hold foot pedal down during time cycle)

(4) OFF = Momentary pedal contact (press foot pedal once)

Caution: Always disconnect the power cord before removing the cover.

# How to Use the Vacuum Control

## Making Timed Deposits of Watery-thin Fluids (Models 900, 900-15, 900-CA)

The vacuum control allows low viscosity fluids, even water, to be consistently dispensed without dripping between cycles. The vacuum exerts a negative pressure on the fluid in the barrel and prevents dripping.

For these tests, you will use the test barrel supplied with the clear fluid.

1. While holding the barrel upright in one hand, remove the orange end cap **1** and insert the blue LV Barrier™ **2**. Allow an air gap as shown.
2. Attach the barrel to the 10cc adapter **3**. Snap the safety clip tightly closed to prevent any dripping or bubbling. Remove the tip cap **4** and attach the 25 gage (red) tip.
3. Set air pressure at 5 psi.
4. Press the timer bypass switch (yellow light on).
5. With the barrel pointing downward over a container, unsnap the safety clip. Then press the foot pedal to fill the tip.
6. Set the timer at #5. Press the timer bypass switch again (yellow light out).
7. If a drop begins to form at the end of the tip, slowly turn the vacuum control knob counterclockwise to stop the drop from growing. Wipe the tip and adjust vacuum as necessary.
8. Take the barrel and place the tip on the test sheet. Press the foot pedal and release. Check the dot size. Increase or decrease by adjusting pressure or time.

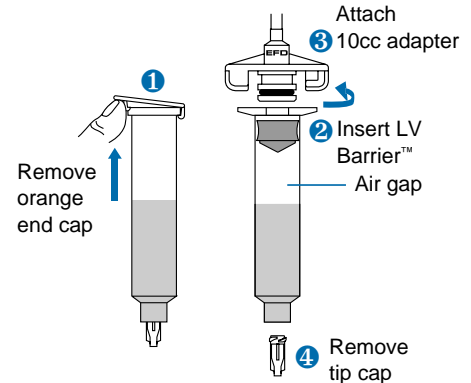

### Three things to remember

If you do not use the piston when dispensing thin fluids:

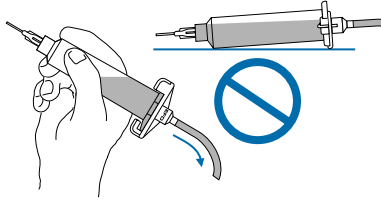

Do not tip the barrel upside down or lay flat. This will cause the liquid to run into the dispenser.

#### Open

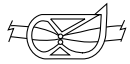

#### Closed

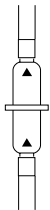

When changing tips or attaching a tip cap, snap the safety clip completely closed to prevent any dripping or bubbling.

Use an EFD filter trap (#1000FLT-Y). This filter trap will impede the flow should the low viscosity liquid be sucked back towards the dispenser.

If you choose **not** to use the piston, please follow these instructions carefully:

1. While holding the barrel upright in one hand, twist on an orange tip cap. Using the small funnel, fill about 2/3 full with your fluid.
2. Open the safety clip and attach the barrel to the 10cc adapter.
3. Close the safety clip as tight as possible.
4. Increase vacuum by turning vacuum control knob counterclockwise and set to 1.5 on the vacuum pressure gauge.
5. Then, without tipping the barrel upside down, remove the tip cap and attach the 25 gage (red) tip.
6. Open the safety clip. Your material may begin to bubble. Reduce vacuum by turning vacuum control knob clockwise.
7. If a drop begins to form at the end of the tip, slowly turn the vacuum control knob counterclockwise to stop the drop from growing. Wipe the tip and adjust vacuum as necessary.

Now the fluid is in proper balance. It does not bubble or drip.

Repeat tests as before, keeping the air pressure low and adjusting the time for different deposit sizes. Contact EFD if you have any questions.



**In the US, call 800-556-3484.**

In Mexico, call 001-800-556-3484.

In the UK, ring free 0800 585733.

## IMPORTANT

Regardless of the fluid viscosity, using the correct EFD piston will give you better results. White SmoothFlow™ piston for most fluids, blue LV Barrier™ for watery-thin fluids and orange flat wall piston for thick, stringy fluids. See pages 12 - 13 for a complete description of how EFD pistons work and the benefits they can bring to your operation.

# Ultra™ Advanced Dispensing System

If you dispense thick fluids, several problems may occur. First, the repetitive air cycles can bore tunnels through non-leveling fluids, causing spitting and inconsistent deposits. Second, thick fluids contain trapped air that leads to drooling and oozing.

These problems are eliminated by using the SmoothFlow™ piston. That's because the white pistons prevent tunneling by providing a barrier to the pulsed-air cycles, and prevent oozing by responding to the pressure of trapped air with a slight suck-back movement after the dispense cycle.

The white piston is used for most fluids.

However, if you are applying RTV silicone and find that the piston bounces and causes stringing, switch to the orange, flat wall piston.

The SmoothFlow™ pistons make barrel filling easier, too. As you load the fluid in, air is trapped in the bottom and throughout the fluid. Simply insert a SmoothFlow™ piston and gently press down on the fluid as far as possible. This action forces out most of the air and results in consistent deposits.

## For Thick Fluids

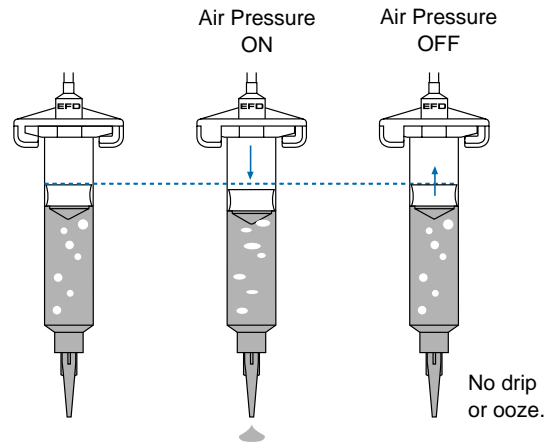

If you use low to medium viscosity fluids, the white SmoothFlow™ piston has several advantages.

First, vacuum adjustment is much less sensitive. Second, the piston prevents fumes from the fluid being exhausted into the work environment. Third, the piston prevents fluid backflow into the dispenser if the barrel is inadvertently turned upside down. Fourth, using the piston makes it easy and safe to change tips without dripping.

**Note:** If you use watery-thin fluids such as solvents, cyanoacrylates and anaerobics, specify the ULTRA System™ with the blue LV Barrier™. Available in 3cc and 10cc sizes.

## For Cyanoacrylates or Watery-thin Fluids

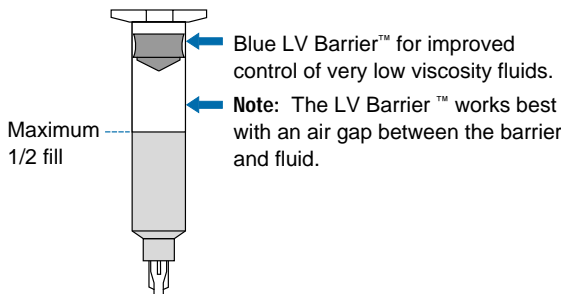

## For Thinner Fluids

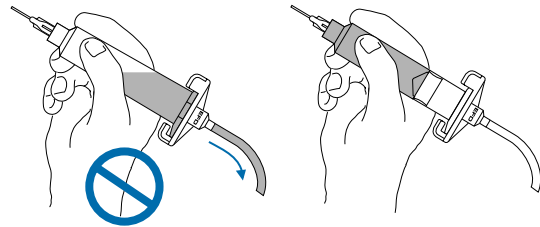

SmoothFlow™ piston prevents fluid backflow.

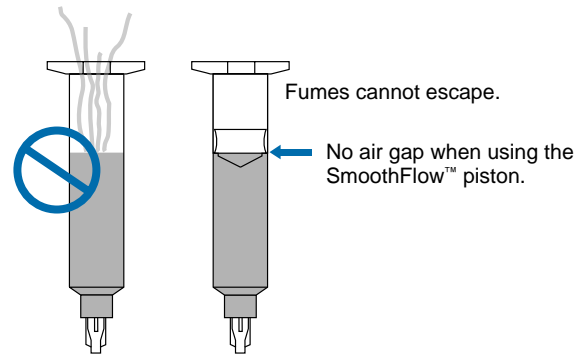

**Note:** If you choose not to use a piston, please refer to page 11 for instructions.

# Loading the Barrel Reservoirs

**Caution:** Do not completely fill barrels. The optimum fill is a maximum 2/3 of the barrel capacity and 1/2 of the barrel capacity when using the LV Barrier™.

If the fluid you are dispensing is pourable, take the barrel, twist on a tip cap and pour your fluid in. If appropriate, insert the SmoothFlow™ piston (see page 13). Carefully press the piston down until it contacts the fluid. The barrel is now ready for use.

If you are dispensing solvents, cyanoacrylates or anaerobics, use the LV Barrier™. Place barrier in the top of the barrel reservoir. Allow air between barrier and fluid. Do not contact the barrier to the fluid.

If your fluid is thick or non-leveling, you can spoon it into the barrel with a spatula. Or, if the fluid comes packed in a 1/10 gallon cartridge, try loading the barrel with a caulking gun. Then press in the SmoothFlow™ piston to move the fluid to the bottom of the barrel and to remove trapped air.

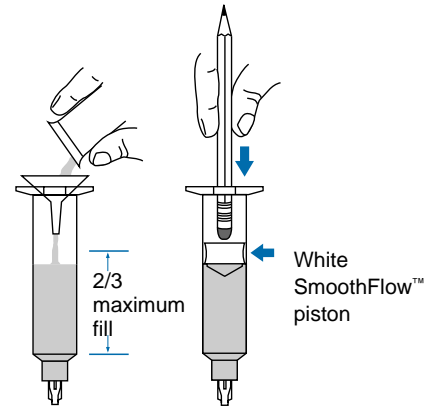

Fill procedure for pourable fluids

Fill procedure for thick fluids (shown: caulking gun)

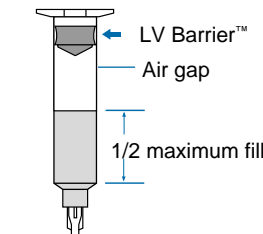
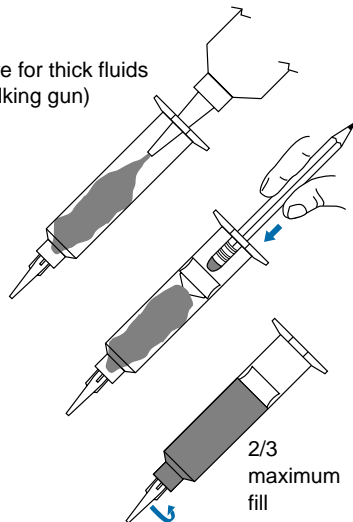

Fill procedure for cyanoacrylates or watery-thin fluids

EFD offers productive alternatives to traditional barrel loading methods. Here are a few suggestions that can help keep your work area clean, save time and reduce the chance of entrapped air in the fluid.

1. You could use the EFD #920BL barrel loader. Pack the fluid into the 12 ounce cartridge as shown. Then place the pre-filled cartridge into the barrel loader. Using air pressure, the barrel loader fills the barrel (with piston) from the bottom up.

If the fluid comes packed in a 1/10 gallon (300 ml.) caulking type cartridge, use the EFD #940BL barrel loader.

2. If you receive frozen epoxies or other fluids in medical type syringes with a manual plunger, ask your fluid packager to use EFD industrial grade barrels, or request our luer-to-luer fitting #2160 to transfer the material.

Please call an EFD Product Specialist for additional assistance.

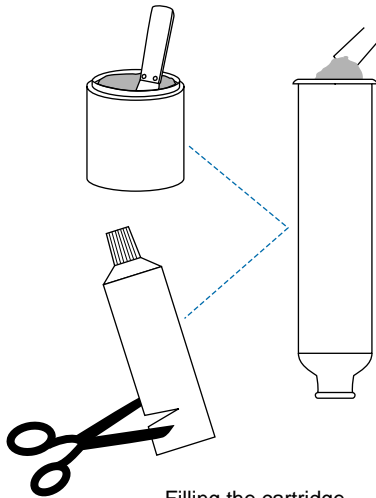

Filling the cartridge for the barrel loader.

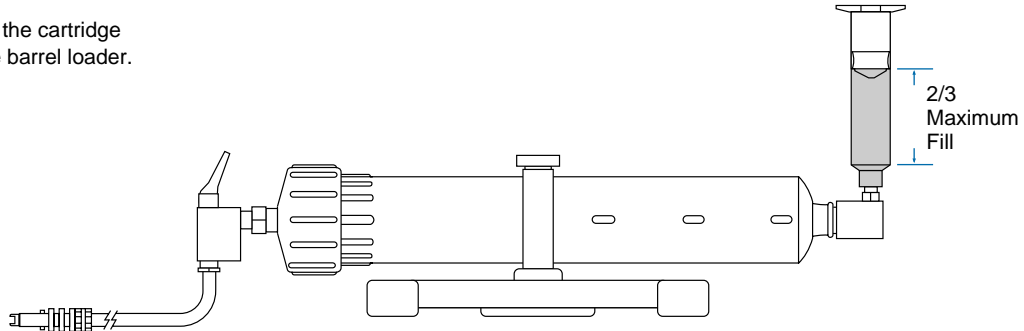

EFD #920BL Barrel Loader  
 (Specify #940BL for prefilled 1/10 gallon caulking tubes)

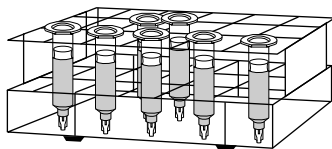

Barrel Rack  
 #905BR holds (72) 3cc and 5cc barrels  
 #910BR holds (24) 10cc, 30cc and 55cc barrels

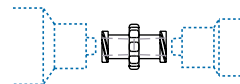

#2160 Luer-to-luer fitting

# Schematic & Parts

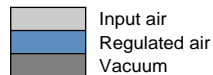
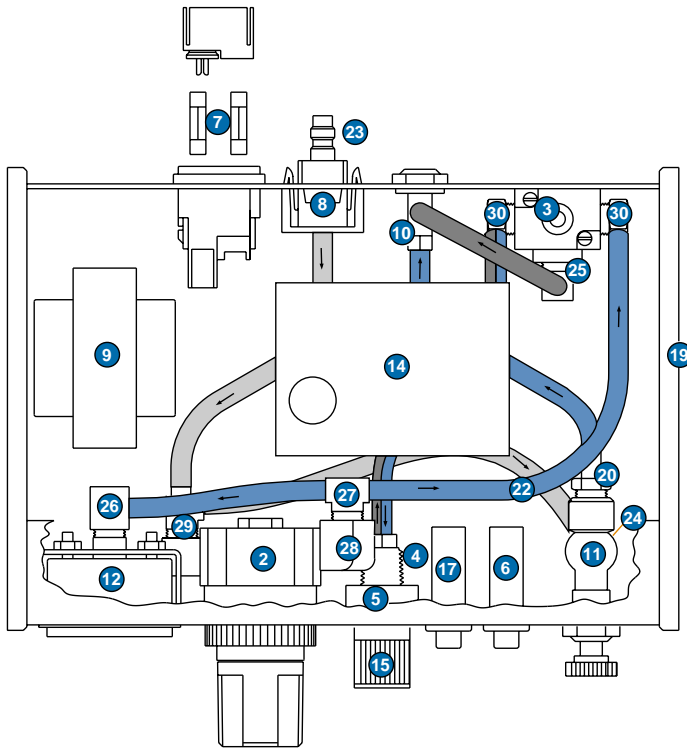

## Replacement Parts List

1. 1000INP-AKIT\* Air input hose-mini coupler
2. 2-2002A-XL Regulator assembly 0 to 15 psi  
2-2002-XL Regulator assembly 0 to 100 psi
3. 2-2003-1000 24 VDC solenoid assembly
4. 2-2004B Quick-connect assembly
5. 2-2007-XL Potentiometer assembly
6. 2-2011-24 Timer bypass switch assembly
7. 7111E Fuse .160A
8. 2-2017A-24XL Foot-pedal receptacle
9. 2-2031-1000 Transformer assembly multi input
10. 2-2170LV Vacuum transducer assembly
11. 2-2176-800 Barrel vacuum control
12. 2001B Gauge 0 to 15 psi, 0 to 1.0 bar  
2001C Gauge 0 to 100 psi, 0 to 7.0 bar
13. 2002SCR\* Replacement screen for regulator
14. 2-2006-24PR Programmable timer
15. 2008A Time control knob with numbers
16. 2009-A24\* Input cord, detachable  
2009-G24\* European cord, detachable
17. 2010-A24 Power switch 115 VAC
18. 2015A\* Foot pedal assembly
19. 2019G Grey dispenser end panel
20. 2032 Fitting 1/8 NPTM x 1/4 barb, brass
21. 2-2033\* Dispense indicator LED
22. 2037 Tubing .170 x 1/4" OD rigid - PE
23. 2081A Male mini air coupler-panel mount
24. 2084\* Air restrictor
25. 2087 Fitting 1/8 NPTM x 1/4 barb elbow brass
26. 2088 Fitting 1/8 NPTF x 1/4 barb elbow brass
27. 2089 Fitting 1/8 NPTM x 1/4 barb tee brass
28. 2169 Fitting 1/8 NPTM x 1/8 FPT elbow
29. 2178 Fitting 1/8 NPTM x 1/4 barb elbow brass
30. 2086 Fitting 1/8 NPTM x 1/4 barb 90 brass

\* Not Shown

# Troubleshooting

## NO POWER

1. Check voltage at wall outlet.
2. Check fuse. Order replacement fuse #7111E.
3. Unplug from wall, remove top cover, visually inspect for any loose or shorted connections.

## POWER, BUT NO LIGHT

Switch module must be replaced.

## POWER, LIGHT, BUT MACHINE DOES NOT OPERATE

1. Unplug power input cord.
2. Check foot pedal connection, foot pedal and internal switch.

## INCONSISTENT DOTS

1. Check dispensing tip, barrel and material for possible clogging.
2. Check air gauge to be sure air pressure is not varying.
3. Check to see if there are air bubbles in the material being dispensed.

## MATERIAL SUCK-BACK

1. Use SmoothFlow™ pistons or LV Barriers™ to prevent this. (See pages 12-13.)
2. If it occurs, attach an empty barrel, (put timer bypass switch on), put barrel in a cup and press the pedal to expel the sucked-back fluid.
3. If problem cannot be corrected, contact an EFD Product Specialist for assistance. Dispensers can be returned to EFD for repair.

## TIMER SEEMS INOPERATIVE

1. Check to be sure timer bypass switch is off (yellow light out).
2. Check DIP switch positions (see page 9).

**Note:** The EFD timer is very reliable. Most questions about the timer are resolved by simply turning the timer bypass switch off (yellow light out).

# Suggestions & Reminders

1. Always use an EFD piston to make your barrel loading, dispensing and handling cleaner, safer and more accurate.

**Caution:** If you dispense watery-thin fluids and choose **not** to use SmoothFlow™ pistons – do not increase vacuum pressure rapidly and do **not** tip the barrel. Vacuum may pull liquid into the air hose; or when tipped, liquid may flow back into the dispenser.

2. Always use new barrels and tips. Carefully dispose of after use. This procedure ensures maximum cleanliness, prevents contamination and provides proper safety.
3. Do not completely fill the barrel. For most fluids, optimum fill is a maximum 2/3 of the barrel capacity. For cyanoacrylates or watery-thin fluids, optimum fill is 1/2 of the barrel capacity.
4. Use the EFD #DS1200 DispenStand™ (supplied with model 900-CA) to help organize bench space. Adapter hose support keeps hose off of the work area. See illustration.
5. Depending on the type of work you are doing, it may be easier to bring the work to the barrel. Mount the barrel on a stand such as the EFD #7300A.
6. To ensure smooth fluid flow and to make consistent deposits, always have the tip at about a 45° angle to the work surface.

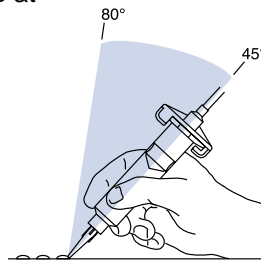
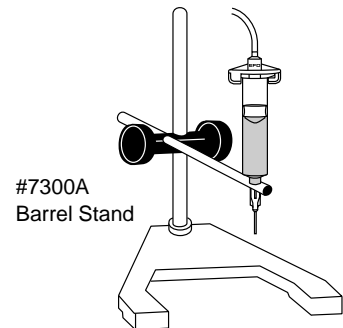
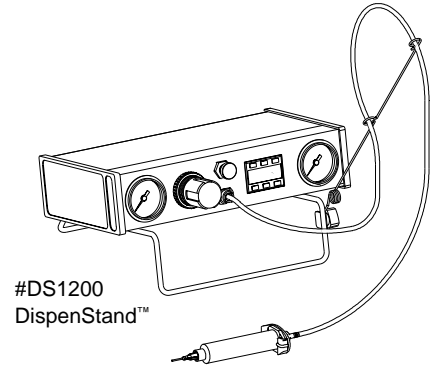

# ULTRA System™ Dispensing Components

For complete selection and technical details, please refer to EFD Catalog and price list.

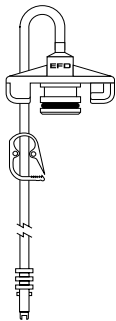

## Barrel adapter assemblies

Molded one-piece, yellow, SnapLok™ adapter head with Buna N O-ring, flexible 5/32" O.D. hose, male quick-connect and safety clip.

size	with 3-ft hose	with 6-ft hose
3cc	1000Y5148	1000Y5148-6
5cc	1000Y5149	1000Y5149-6
10cc	1000Y5150	1000Y5150-6
30cc/55cc	1000Y5152	1000Y5152-6

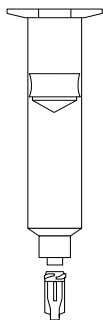

Each box contains the same quantity of barrels and pistons.

Thin to thick fluids (white SmoothFlow™ piston).

size	UV-block			sets/ box
	clear	amber	opaque black	
3cc	5109CP-B	5109AP-B	5109UP-B	50
5cc	5110CP-B	5110AP-B	5110UP-B	40
10cc	5111CP-B	5111AP-B	5111UP-B	30
30cc	5112CP-B	5112AP-B	5112UP-B	20
55cc	5113CP-B	5113AP-B	n/a	15

Cyanoacrylates/watery-thin fluids (blue LV Barrier™)

size	clear barrel, LV Barrier™ & tip cap		sets/ box
	3cc	10cc	
3cc	5109LV-B	5111LV-B	50
10cc	5109LV-B	5111LV-B	30



## Smooth-flow tapered tips

Molded polyethylene with UV block. Packaged (50) tips per see-through box for easy part identification.

gage	ID	tapered	color
14	.063"	5114TT-B	olive
16	.047"	5116TT-B	grey
18	.033"	5118TT-B	green
20	.023"	5120TT-B	pink
22	.016"	5122TT-B	blue
25	.010"	5125TT-B	red

## General purpose precision tips

All EFD dispensing tips incorporate the unique SafetyLok™ color-coded polypropylene hubs. Conveniently packaged (50) tips per see-through box for easy part identification.

gage	ID	1/2" length	hub color
14	.061"	5114-B	olive
15	.054"	5115-B	amber
18	.033"	5118-B	green
20	.024"	5120-B	pink
21	.020"	5121-B	purple
22	.016"	5122-B	blue
23	.013"	5123-B	orange
25	.010"	5125-B	red
27	.008"	5127-B	clear
30	.006"	5130-B	lavender



## Useful accessories

**#2000F755:** Five micron filter regulator provides proper air filtering for all dispensers. Order if you do not have dry, clean, filtered factory air supply.

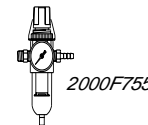

**#2000F756:** Five micron filter regulator with coalescing filter. Removes liquid aerosols from air supply for cyanoacrylate applications. (Supplied with the 900-CA dispenser.)

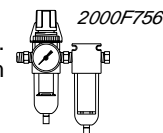

**#7300A:** Barrel stand, fully adjustable three axes.

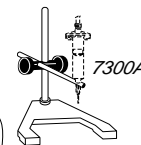

**#DS1400:** DispenStand™ holds dispenser vertically.

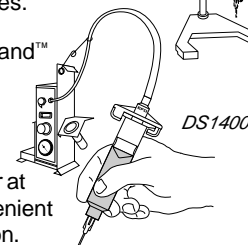

**#DS1200:** Horizontal stand tilts dispenser at a 14° angle for convenient viewing and operation.