

790 Dispense Valve

INSTALLATION GUIDE

Electronic pdf files of EFD[®] manuals are also available at www.efd-inc.com/manuals.html.

USA & Canada: 800-556-3484 or +1-401-434-1680
 Europe: 0800 585733 or +44 (0) 1582 666334
 Asia: +86 (21) 5854 2345
technical@efd-inc.com www.efd-inc.com

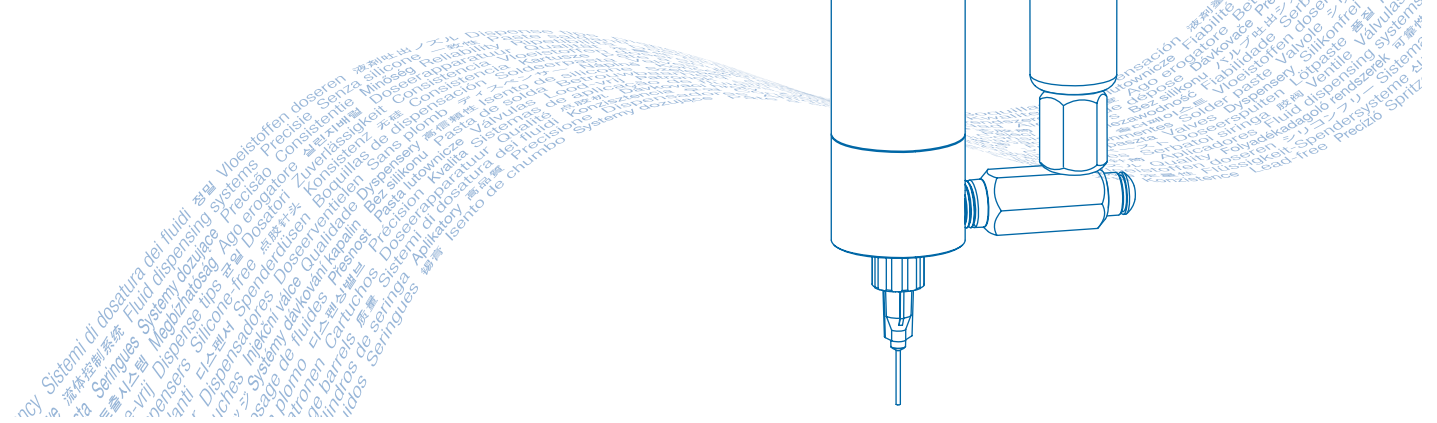
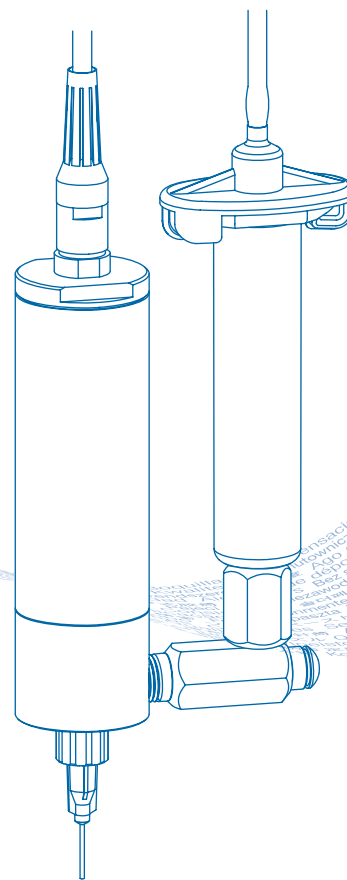

Introduction

The 790 is a precision dispense valve specifically designed for metering controlled deposits of solder pastes, thick sealants and other particle-filled materials.

By combining screw-feed principles with precise time, pressure and dispensing control, the 790 valve is able to provide accurate, repeatable deposits without damaging the metal particles of the solder. These features are not possible with any other type of conventional control valve.

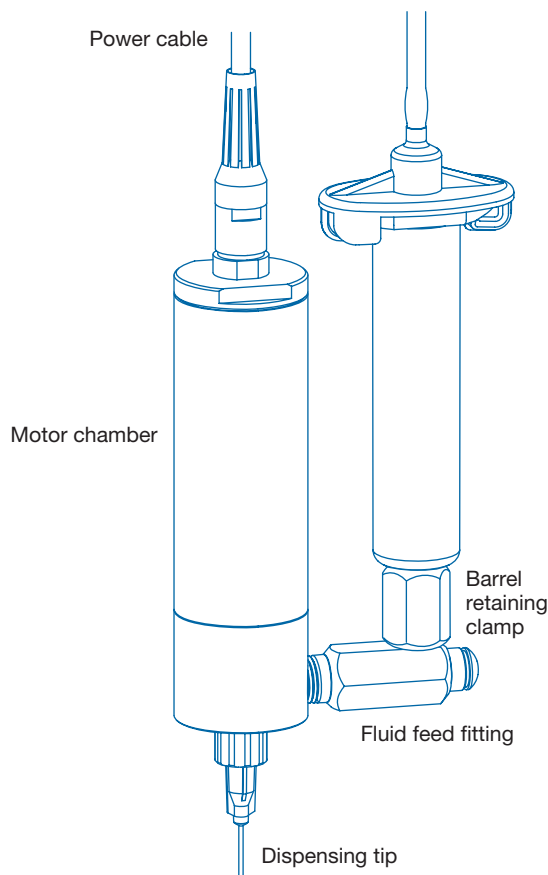

Installation

Prior to installing this valve, please read the associated reservoir and valve controller operating instructions to become familiar with the operation of all components of the dispensing system.

1. Connect the motor lead wire to the I/O connector position 7 (white wire) and position 8 (brown wire).
2. Install the barrel of red purge compound (supplied) onto the dispense valve-inlet fitting.
3. Press the barrel into the fitting while rotating one-half turn clockwise. Do not overtighten.
4. Attach the yellow end of the barrel adapter assembly to the barrel of red purge compound.
5. Install the black quick-connect into the air output connector labeled "Constant Pressure."
6. Install a pink 20 gauge dispensing tip (supplied, part #5120-1/4) onto the valve outlet.

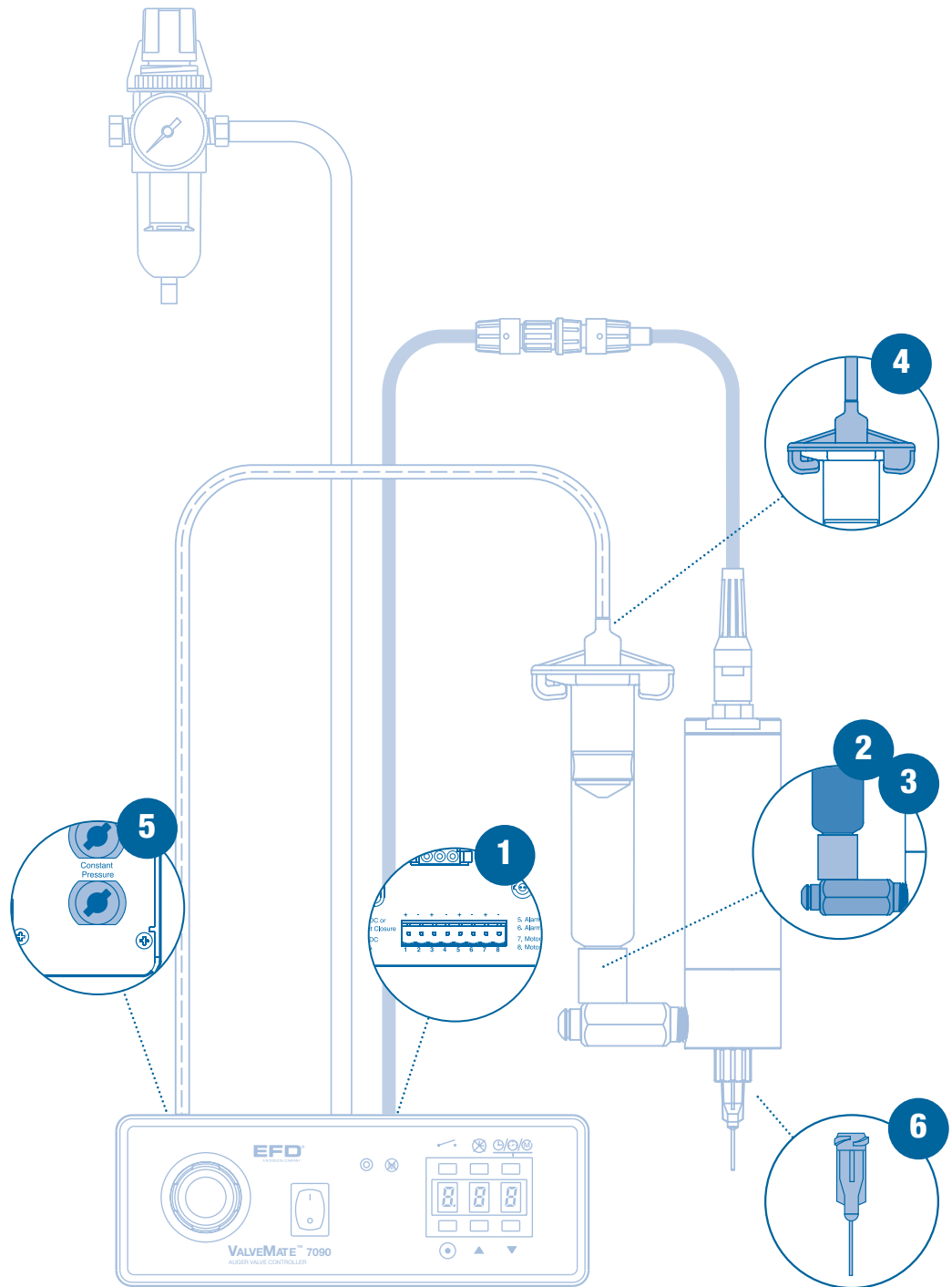

How the Valve Operates

Input-air pressure at 65 psi (4.5 bar) is applied to the material reservoir, forcing fluid ① into the path of the auger. As the auger rotates, fluid moves along the auger flutes ② and is forced-out through the dispense orifice.

The ValveMate™ 7090 controller regulates the reservoir pressure, ensuring that there is enough pressure to keep the valve primed with fluid without forcing it past the auger.

Duration of the dispensing time is controlled by adjusting the time control up or down until the required deposit size is established, at which point it is repeated with each initiate cycle.



open

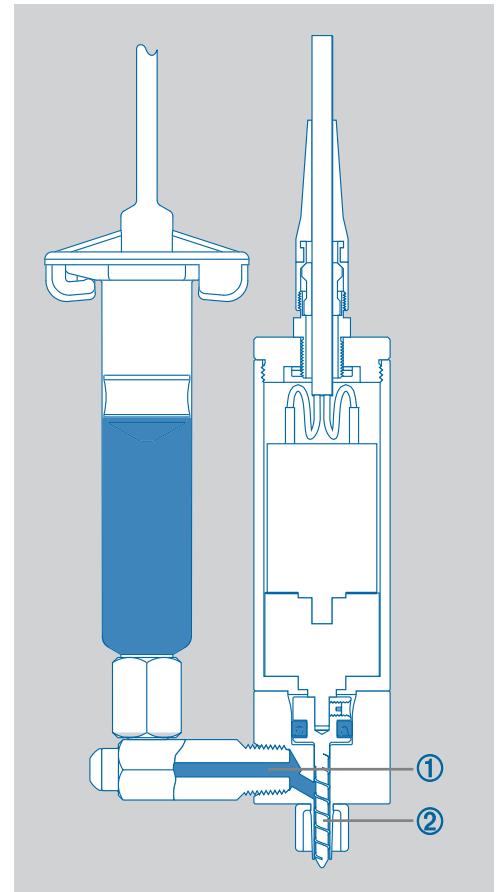

closed

ValveMate Concept

The ValveMate 7090 provides easy adjustment of valve output for maximum end-user convenience and efficiency. Valve open-time is the primary control of deposit. The 7090 puts push-button adjustment of valve open-time where it needs to be – at the valve.

Microprocessor circuitry provides exact control of the spray valve to achieve exceptional spray pattern definition. The ValveMate 7090 also incorporates microprocessor-controlled functions that include motor start-up acceleration limits

and maximum current overload protection for extended motor life.

Deposit size can be programmed by pressing the PROGRAM button in the SETUP mode. This affords an easy starting point for selecting deposit size.

Note: The EFD Ultra® TT 325 and 525 XYZ automated dispensing systems have integrated ValveMate controllers for operating all EFD dispense valves.

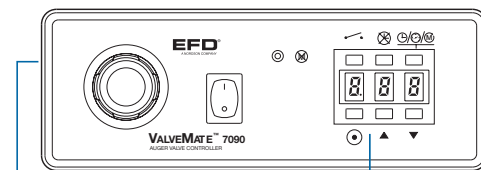

Rear Panel
air input
power input
(voltage selector)
air output to valve
connector for
optional foot pedal

Control Pad
set time
timer bypass
display – pressure (psi, bar)
– time
– motor volts
TEACH program
test cycle
purge
reset

www.efd-inc.com technical@efd-inc.com USA & Canada 800-556-3484 Europe +44 (0) 1582 666334 Asia +86 (21) 5854 2345



Specifications

General

Size: 155.4 mm length x 28.7 mm diameter (6.12" x 1.13")

Weight: 314 grams (11.07 oz)

Fluid body: Type 303 stainless steel (Acetal optional)

Auger: Type 303 stainless steel (Acetal optional)

"U" cup: Viton®

Fluid feed fitting: Type 303 stainless steel (Polypro optional)

Auger speed: 250 RPM (400 RPM optional)

Auger pitch: 8 threads per inch (16 threads per inch optional)

Maximum continuous current: SR & FR – 240 mA, SB & FB – 670 mA (Time delay fuse recommended)

China RoHS Hazardous Material Declaration

Part Name	Toxic or Hazardous Substances and Elements					
	Lead (Pb)	Mercury (Hg)	Cadmium (Cd)	Hexavalent Chromium (Cr6)	Polybrominated Biphenyls (PBB)	Polybrominated Diphenyl Ethers (PBDE)
All brass fittings	X	0	0	0	0	0

0: Indicates that this toxic or hazardous substance contained in all the homogeneous materials for this part, according to EIP-A, EIP-B, EIP-C is below the limit requirement in SJ/T11363-2006.

X: Indicates that this toxic or hazardous substance contained in all the homogeneous materials for this part, according to EIP-A, EIP-B, EIP-C is above the limit requirement in SJ/T11363-2006.

For consistent dispense valve operation and easy adjustment of valve output, EFD recommends using the ValveMate 7090 controller on all automatic, semi-automatic and benchtop applications.

The EFD Ultra TT Series positioning systems incorporate dispensing control into the main system.

Contact the EFD Dispense Valve Systems Group for details.



For EFD sales and service in over 30 countries, contact EFD or go to www.efd-inc.com/contact

EFD, Inc.

East Providence, RI USA

USA & Canada: 800-556-3484; +1-401-434-1680

info@efd-inc.com

www.efd-inc.com

EFD International Inc.

Dunstable, Bedfordshire, UK

0800 585733 or +44 (0) 1582 666334

Ireland 00800 8272 9444

europa@efd-inc.com

www.efd-inc.com

EFD, Inc., Asia

China: +86 (21) 5854 2345

china@efd-inc.com

www.efd-inc.com/cn

Singapore: +65 6896 9630

sin-mal@efd-inc.com

Viton is a registered trademark of E.I. DuPont.

The Wave Design is a trademark of Nordson Corporation.

©2007 Nordson Corporation 790-INSTALL-01 v022607



This equipment is regulated by the European Union under WEEE Directive (2002/96/EC). See www.efd-inc.com for information about how to properly dispose of this equipment.