

787MS-SS Series Spray Valve

INSTALLATION GUIDE



Electronic pdf files of EFD® manuals are also available at www.efd-inc.com

USA & Canada: 800-556-3484 or +1-401-434-1680
Europe: 0800 585733 or +44 (0) 1582 666334
Asia: +86 (21) 3866 9166
technical@efd-inc.com www.efd-inc.com

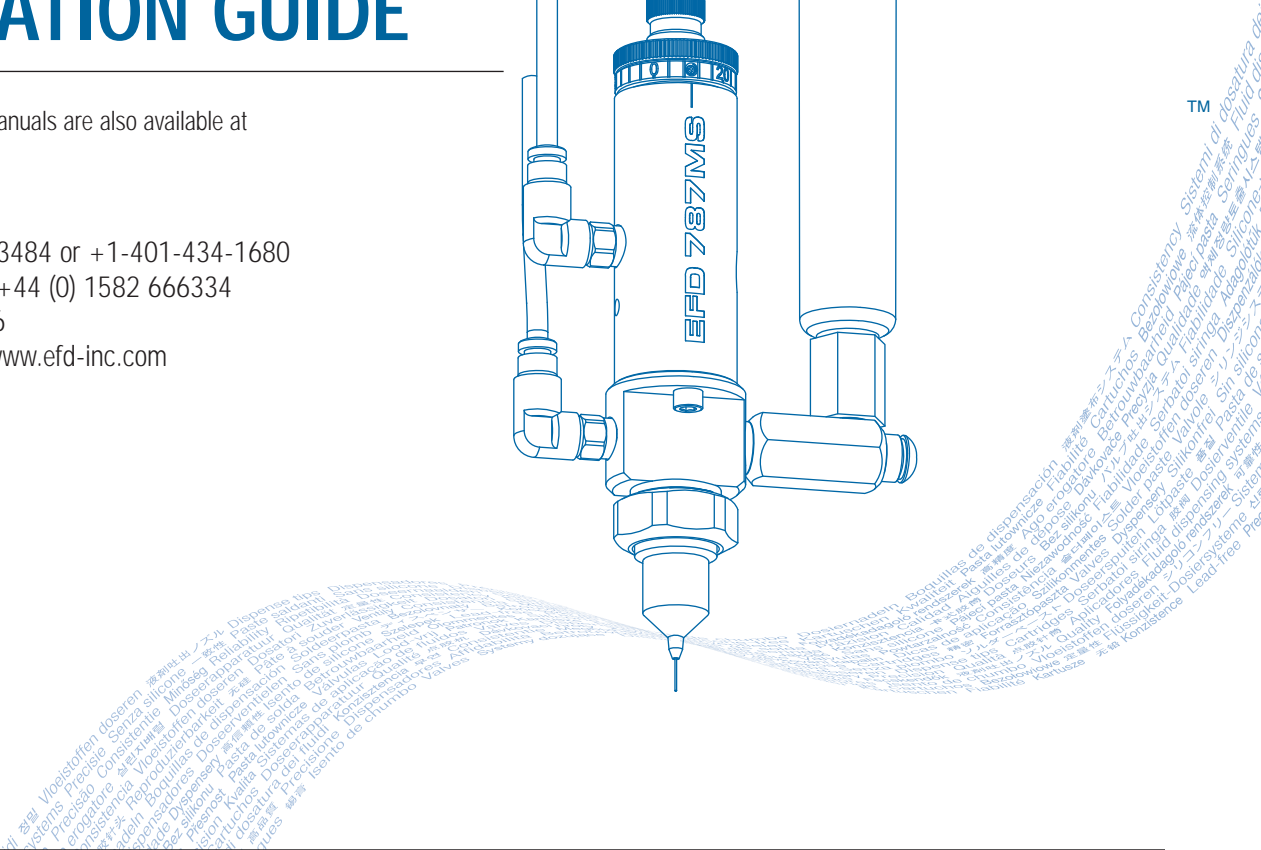
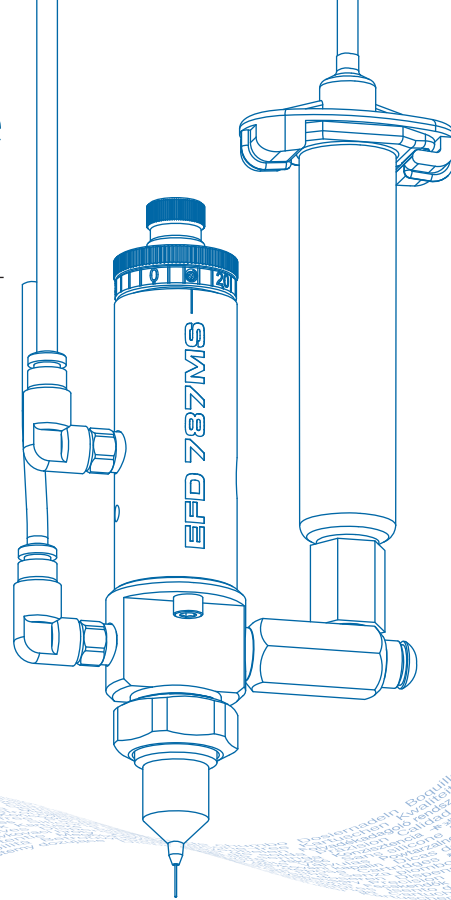

Introduction

The 787MS-SS Series is a low volume low pressure (LVLP) liquid micro spray valve that utilizes small disposable dispensing tips (from 23 to 33 ga). High transfer efficiency onto surfaces without overspray or airborne mist.

The 787MS-SS is a pneumatically operated, adjustable needle valve designed to apply micro spray deposits from 0.130" to 0.75" diameters of low to medium viscosity fluids. Spray valve cleaning is accomplished by purging with appropriate solvent.

The 787MS-SS provides exceptional control and the absolute minimum dead volume.

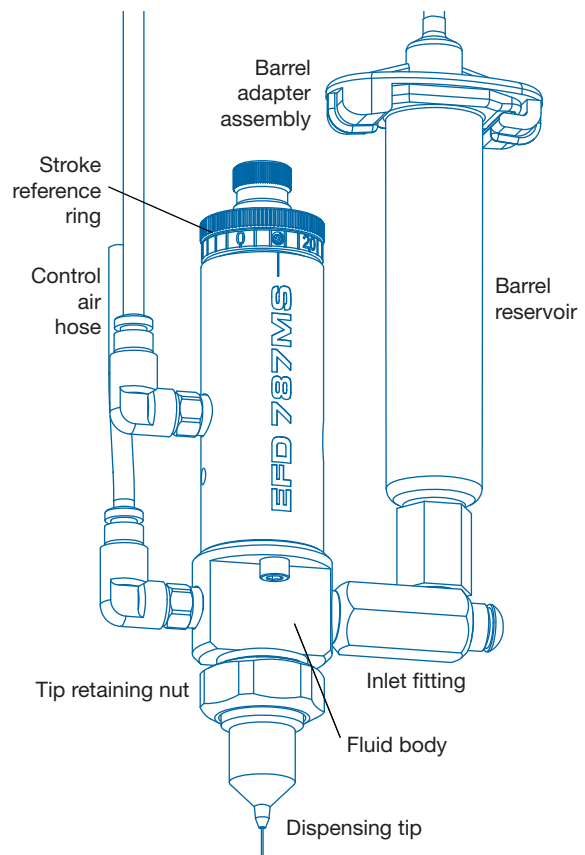

Installation

Prior to installing this valve, please read the associated reservoir and valve controller operating instructions to become familiar with the operation of all components of the spray system.

1. Connect valve control air and nozzle air hoses to ValveMate™ 8040 (dual solenoid pack) used to control valve open time (white hose) and nozzle air (black hose).
2. Connect the white male quick-connect on the flexible air line to the white female quick-connect at the reservoir air pressure regulator.
3. Install the barrel reservoir on the fluid inlet fitting (installed for use with Ultra® barrel reservoirs). For low viscosity fluids, fill the reservoir after installing it on the fluid-inlet fitting. Note: Fill barrels no more than 2/3 full.
4. Attach the barrel adapter head to the barrel reservoir using air interconnect coupler to connect the barrel adapter assembly to the flexible air line.
5. Using the Mode **MODE** button on the ValveMate controller, place the controller in the PURGE **PURGE** mode. In PURGE **PURGE** mode only, channels **1** and **2** can be selected **SEL** independently without nozzle air pressure.
6. Using the needle stroke control knob on the 787MS-SS valve, set the fluid flow rate to one or two drops per second. Check flow rate by actuating the controller in the time override mode. Make valve stroke adjustments when the controller is off.
7. Set the nozzle air pressure on the nozzle to 10 psi (0.7 bar) and actuate the controller. The valve will produce a fine spray. To change fluid flow, use the needle stroke control knob and/or reservoir pressure. To change nozzle air, use the nozzle air pressure regulator. Higher pressures will provide finer spray.

Note: The area of spray coverage is determined by the distance between the spray valve nozzle and the work surface.

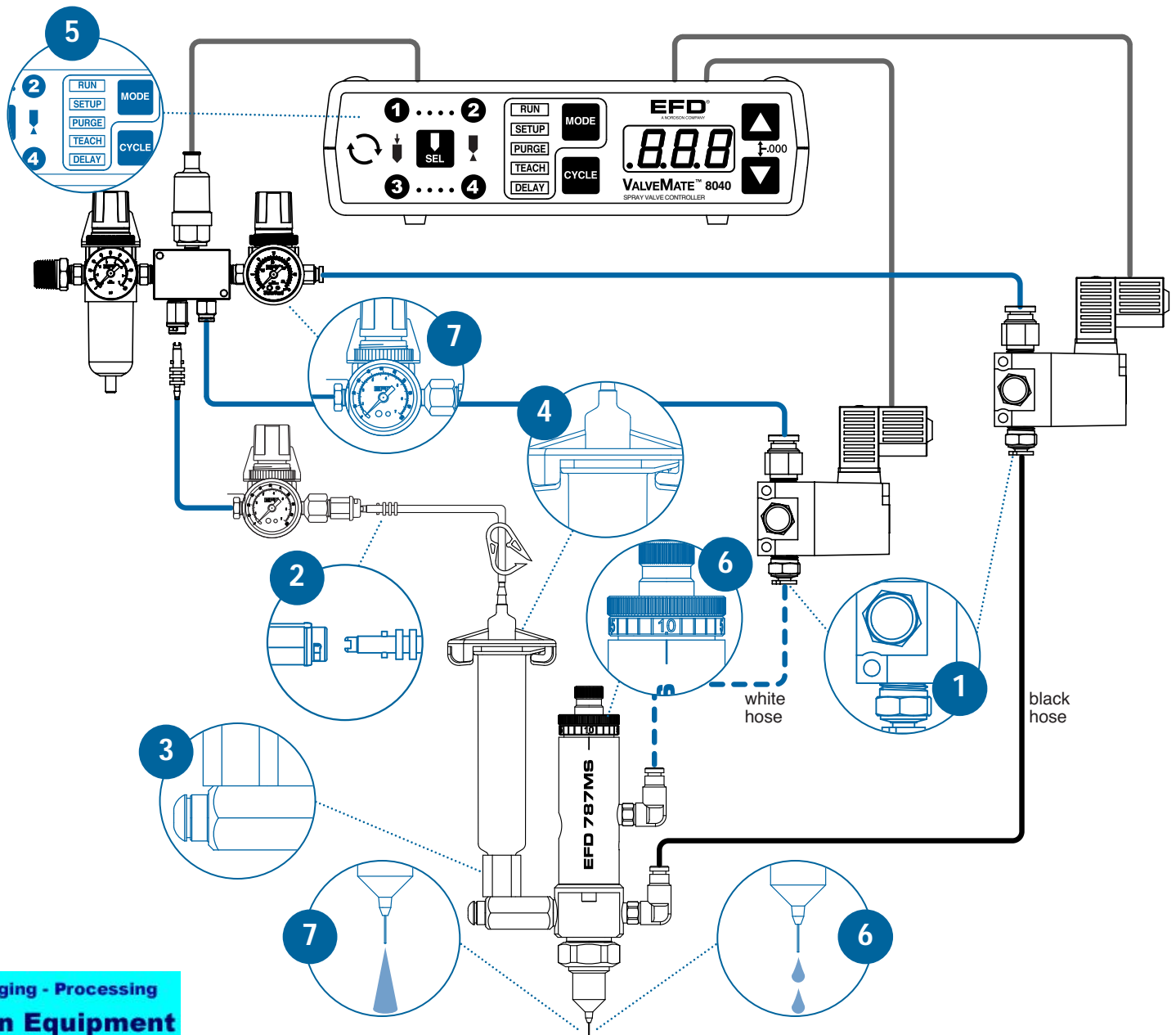

How the Valve Operates

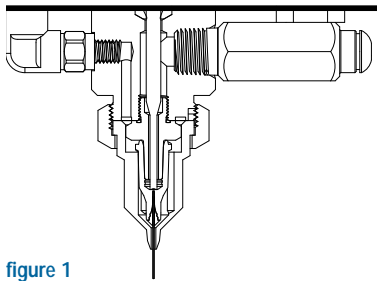

figure 1

Figure 1 Input air pressure at 70 (4.8 bar) retracts the piston and needle from the needle seat in the dispensing tip, permitting fluid flow through the dispensing tip.

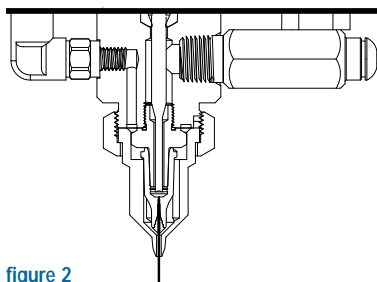

figure 2

Figure 2 At the same time, nozzle air is turned on and flows from an annulus around the dispensing tip. This adjustable nozzle air creates a pressure drop around the dispensing tip causing liquid to atomize in fine micro deposits.

The amount sprayed is controlled by the valve opening time, reservoir pressure, and needle stroke. Area of coverage is determined by dispensing tip selection and distance between the tip and work surface.

When the dispensing tip is removed, the needle seats into a secondary seat, stopping fluid flow during tip replacement.

Figure 3 Replacing the Dispensing tip

- 1 Turn the retaining nut counterclockwise and remove nut and air cap.
- 2 Remove dispensing tip if installed from tip adapter.
- 3 Reinstall dispensing tip positioning the hub against the shoulder of the tip adapter.
- 4 Reinstall air cap and tighten the retaining nut.

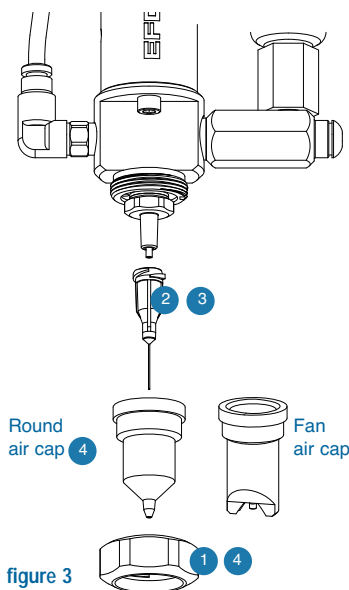

figure 3

Calibration Feature

The stroke control reference ring of each 787MS-SS valve is factory calibrated to the zero position. Slight variations in dispensing tips may require the stroke control to be recalibrated when tips are changed. To do so:

1. Make a note of a current stroke setting number.
2. Turn the calibration knob (inner) counterclockwise one full turn.
3. Install the new dispensing tip and ensure that the retaining nut is tightened fully.
4. Turn the stroke adjustment knob (outer) clockwise until it stops at the zero position.
5. Turn the calibration knob clockwise until it stops. The stroke adjustment is now calibrated to zero.
6. Reset stroke to required position noted in step 1.

In the event that the stroke reference ring must be repositioned or reset to zero mark, use the following procedure:

- A. Remove the dispensing tip, if installed.
 - B. Turn the small knob counterclockwise one full turn.
 - C. Turn the large knob clockwise until it stops.
- If zero on the reference ring does not line up with the index mark, continue the following steps:
- D. Loosen the small set-screw located on the reference ring.
 - E. Rotate reference ring until it aligns with the reference line on the air cylinder body.
 - F. Tighten the small set-screw to lock the reference ring into position.
 - G. Install a dispensing tip and follow calibration procedure steps 3 to 5.

The primary control of deposit size is the valve open time.

ValveMate Concept

The ValveMate 8040 provides easy adjustment of spray valve output for maximum end-user convenience and efficiency. Valve open time is the primary control of deposit. The 8040 puts adjustment of valve open time where it needs to be—near the spray valve.

External solenoids, combined with a 0-30 psi nozzle air pressure regulator, provide Low Volume Low Pressure (LVLP) air to the nozzle, for high transfer efficiency.

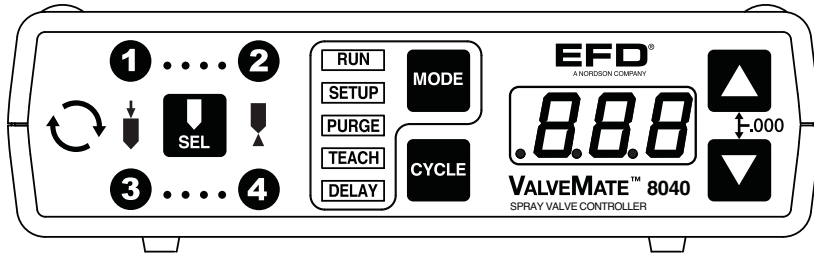

Important Note: Order your single or dual valve solenoid assemblies separately. Consult EFD for recommendations.

Area of Coverage Chart				
		Distance From Surface		
		.5"	1"	1.5"
Tip	Gauge	Round Pattern – 1/4" length tip		
7018301	23	.260	.320	.375
7018332	25	.240	.280	.350
7018394	27	.200	.270	.300
7018423	30	.190	.240	.275
7018461	32	.180	.220	.260
7018477	33 chamfered	.130	.180	.240
Tip	Gauge	Round Pattern – 1/2" length tip		
7018300	23	.280	.430	.600
7018331	25	.240	.330	.400
7018393	27	.220	.300	.375
7018422	30	.200	.280	.350

Area of Coverage Chart				
		Distance From Surface		
		.5"	1"	1.5"
Tip	Gauge	Fan Pattern – 1/4" length tip		
7018301	23	1.30	1.50	1.600
7018332	25	.900	1.200	1.450
7018394	27	.800	1.100	1.300
7018423	30	.450	.600	.900
7018461	32	.400	.570	.800
7018476	33 chamfered	.370	.550	.750

Note: Above are approximate spray pattern areas of coverage. Results may vary based on fluid type, nozzle air, stroke setting and reservoir pressure selected.

Specifications

787MS-SS

Size: 131.6 mm length x 26.9 mm diameter (5.18" x 1.06")

Weight: 336 grams (11.8 oz)

Fluid body: Type 303 stainless steel

Air cylinder body: Type 303 stainless steel

Piston: Type 303 stainless steel

Needle: Type 303 stainless steel

Fluid inlet thread: 1/8 NPT female

Air cap: Type 303 stainless steel

Free flow orifice: 33 ga (.004, 0.10mm) to 23 ga (.013, 0.33mm)

Needle packagings: Teflon®

Mounting: ¼-28 UNF tapped hole

Maximum fluid pressure: 100 psi (7 bar)

Maximum operating temperature: 102°C (215°F)

Operating frequency: Exceeds 400 cycles/minute

Note: All stainless steel valve parts are passivated.



For EFD sales and service in over 30 countries, contact EFD or go to www.efd-inc.com

EFD, Inc.

East Providence, RI USA

USA & Canada: 800-556-3484; +1-401-434-1680

info@efd-inc.com

www.efd-inc.com

EFD International Inc.

Dunstable, Bedfordshire, UK

0800 585733 or +44 (0) 1582 666334

Ireland 00800 8272 9444

europe@efd-inc.com

www.efd-inc.com

EFD, Inc., Asia

China: +86 (21) 3866 9166

china@efd-inc.com

www.efd-inc.com

Singapore: +65 6796 9630

sin-mal@efd-inc.com

Teflon is a registered trademark of DuPont.

The Wave Design is a trademark of Nordson Corporation.

©2008 Nordson Corporation 787-INSTALL-01 (SAP#) 7012743 v061808