

782RA Spray Valve

INSTALLATION GUIDE

Electronic pdf files of EFD[®] manuals are also available at www.efd-inc.com/manuals.html.

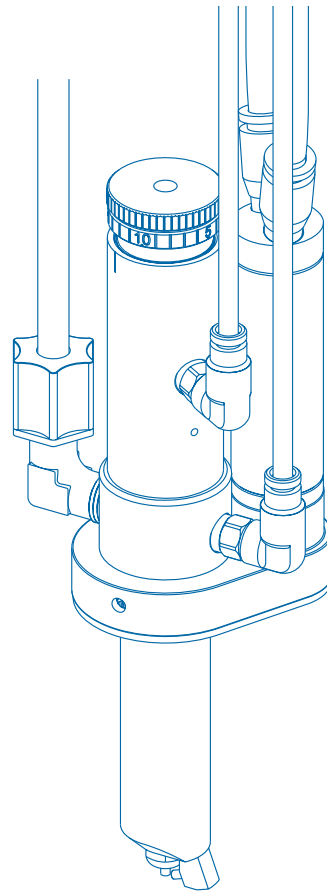

USA: 800-556-3484 or +1-401-434-1680
Europe: 0800 585733 or +44 (0) 1582 666334
Asia: +86 (21) 5854 2345
technical@efd-inc.com www.efd-inc.com

Introduction

The 782RA is a precision, air-actuated spray valve that produces a narrow radial output ideal for coating the interiors of cylinders. LVLV (low volume low pressure) air is used to atomize the fluid, while a precision air motor drives a rotating air cap that produces the radial output.

The 782RA valve has a 5.6 cm (2.2") extended rotor air cap that will reach inside cylinders with a minimum inner diameter of 2.5 cm (1.0"). The valve is simple to use and will operate many millions of cycles without maintenance.

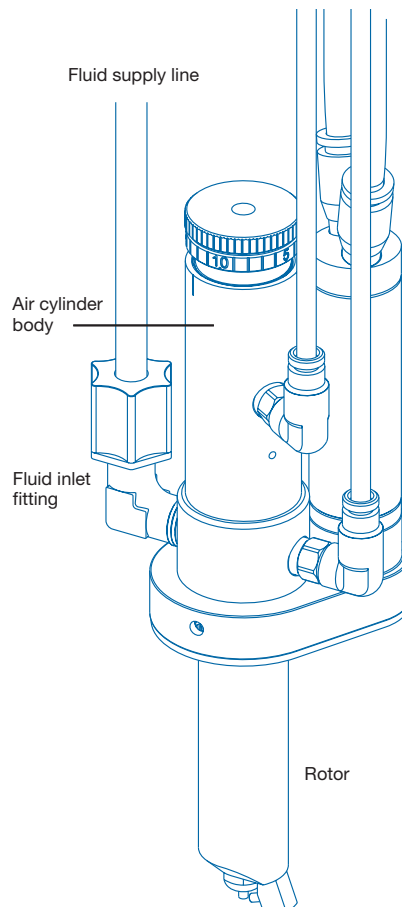

Installation

Prior to installing this valve, please read the associated reservoir and valve controller operating instructions to become familiar with the operation of all components of the dispensing system.

*Air Preparation Assembly: See pages 6 – 7,
 ValveMate 7060RA Controller Operating Manual.*

- 1.** Mount valve using the 1/4-28 UNF tapped hole on the air cylinder body.
- 2.** Connect the fluid feed hose to the reservoir outlet and the valve-inlet port using the appropriate fittings (supplied).
- 3.** Connect the 4 mm diameter air hoses from the valve to the controller. The white goes to the “A” port and the black goes to the “B” port.
- 4.** Connect the 6 mm diameter air hoses from the motor to the air preparation assembly. The white connects to the control valve. The black connects to the motor speed control fitting.
- 5.** Fill the fluid reservoir. After filling, secure the cover and connect the reservoir air pressure regulator to the air tee using the flexible air line (supplied). Attach the black male quick-connect on the air line to the reservoir regulator and then attach the white quick-connect to the air tee. To pressurize the system, slide the shut-off valve on the air line toward the fluid reservoir.
- 6.** Set the reservoir pressure regulator according to fluid viscosity, to low for thin fluids 1 to 3 psi (0.07 to 0.2 bar) and higher for thick fluids.
- 7.** Set the needle stroke control at one turn open. This is a starting point. Final setting will be determined by the desired flow rate.

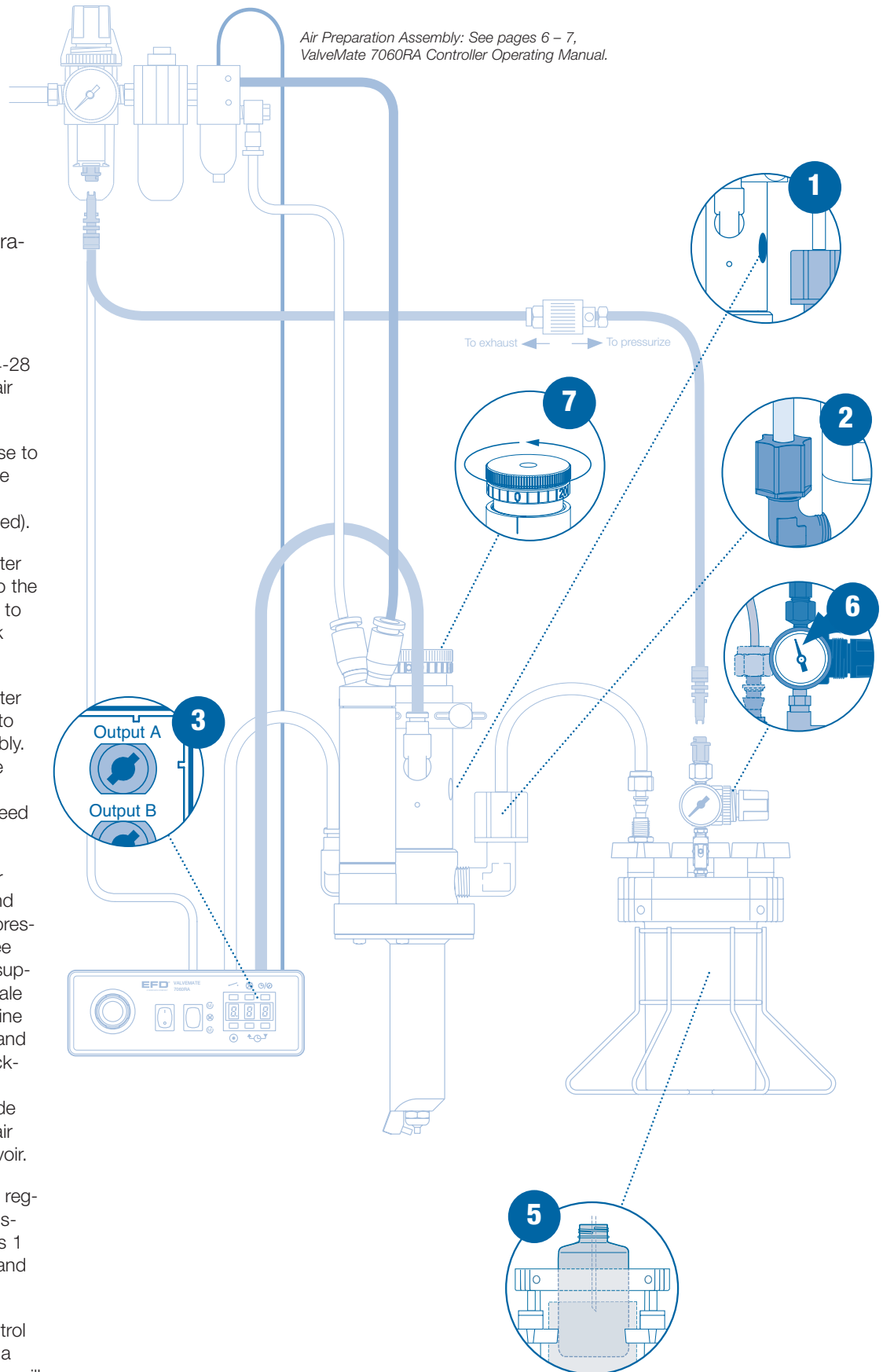

How the Valve Operates

Input-air pressure at 70 psi (4.8 bar) acts on a piston ① that retracts the needle ② from its nozzle seat ③, permitting fluid flow from the nozzle ④. At the same time, atomizing air from the ValveMate™ 7060RA controller is turned on and flows from the rotor air tube ⑤ across the fluid nozzle at a 70° angle. This atomizing air creates a pressure drop around the nozzle, causing fluid to atomize into fine droplets and follow the direction of the atomizing air flow. The rotor, spinning at approximately 2500 rpm, causes the radial output to sweep around and evenly coat the inner circumference of the cylinder.

When the timed actuating air from the ValveMate 7060RA controller shuts off, the piston spring moves the needle onto the nozzle seat and shuts-off fluid flow. An adjustable atomizing air delay ensures that all fluid is atomized after the valve closes, eliminating post-deposit spatter.

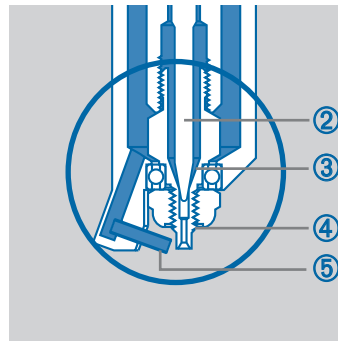

open

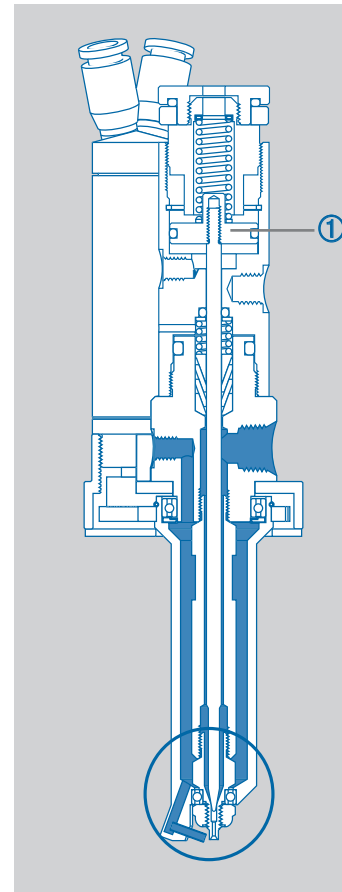

closed

ValveMate Concept

The ValveMate 7060RA provides easy adjustment of valve output for maximum end-user convenience and efficiency. Valve open-time is the primary control of deposit size. The 7060RA puts push-button adjustment of valve open time where it needs to be – at the valve.

The controller incorporates unique microprocessor circuitry to provide exact time control and interact with the host computer. A built-in air pressure regulator provides low volume low pressure nozzle air to ensure high

transfer efficiency without overspray.

Deposit size can be programmed by pressing the PROGRAM button in the SETUP mode. This affords an easy starting point for selecting deposit size.

Note: The EFD Ultra® TT 325 and 525 XYZ automated dispensing systems have integrated ValveMate controllers for operating all EFD dispense valves.

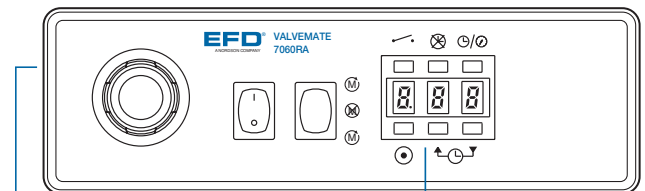

- Rear Panel**
- air input
 - power input
 - air output to valve
 - I/O interface terminal strip
 - air exhaust
 - atomizing air output
 - connector for optional foot pedal

- Control Pad**
- cycle / test
 - time override
 - time / pressure and psi / bar toggle
 - program
 - time set

www.efd-inc.com technical@efd-inc.com USA 800-556-3484 Europe +44 (0) 1582 666334 Asia +86 (21) 5854 2345



Specifications

General

Size: 174.5 mm length x 68.6 mm diameter (6.87" x 2.70")

Weight: 408.2 grams (14.4 oz)

Air consumption: <0.3 SCFM at 80 psi (5.4 bar)

Air cylinder body: Hard-coated aluminum

Fluid body: Hard-coated aluminum

Piston: Type 303 stainless steel

Piston return spring: Stainless steel

Needle and nozzle: Stainless steel

Rotor: Hard-coated aluminum

Fluid inlet hole: 1/8 NPT female

Air pressure required: 70 psi (4.8 bar)

Mounting: 1/4-28 UNF tapped hole

Spray Coverage

782RA distance from nozzle center to inside diameter of cylinder wall.

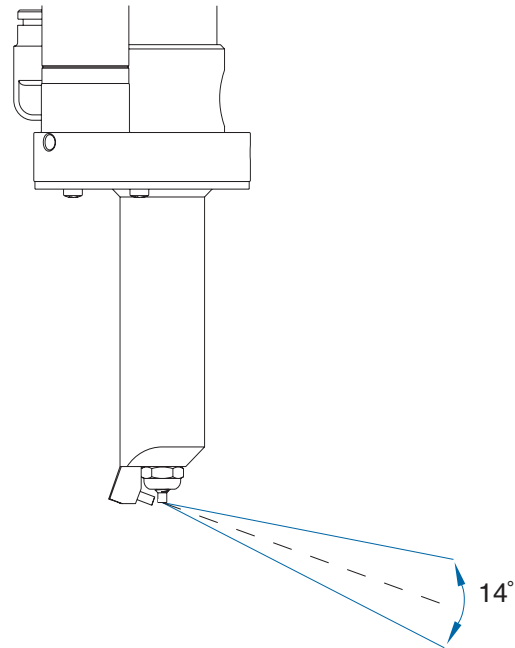
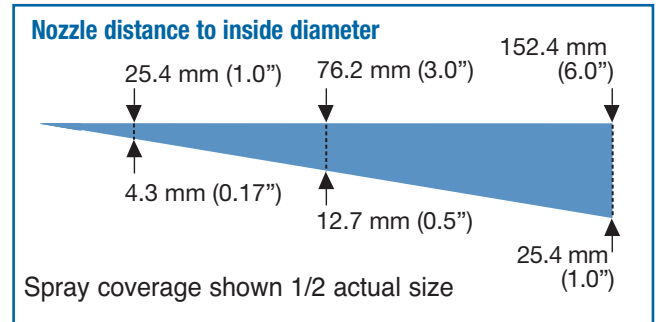

For consistent dispense valve operation and easy adjustment of valve output, EFD recommends using the ValveMate 7060RA controller on all automatic, semi-automatic and benchtop applications.

The EFD Ultra TT Series positioning systems incorporate dispensing control into the main system.

Contact the EFD Dispense Valve Systems Group for details.



For EFD sales and service in over 30 countries, contact EFD or go to www.efd-inc.com/contact

EFD, Inc.

East Providence, RI USA
800-556-3484; +1-401-434-1680 (outside the USA)
info@efd-inc.com www.efd-inc.com

EFD International Inc.

Dunstable, Bedfordshire, UK
0800 585733 or +44 (0) 1582 666334
Ireland 00800 8272 9444
europe@efd-inc.com www.efd-inc.com

EFD, Inc., Asia

China: +86 (21) 5854 2345
china@efd-inc.com www.efd-inc.com/cn
Singapore: +65 6896 9630 sin-mal@efd-inc.com