

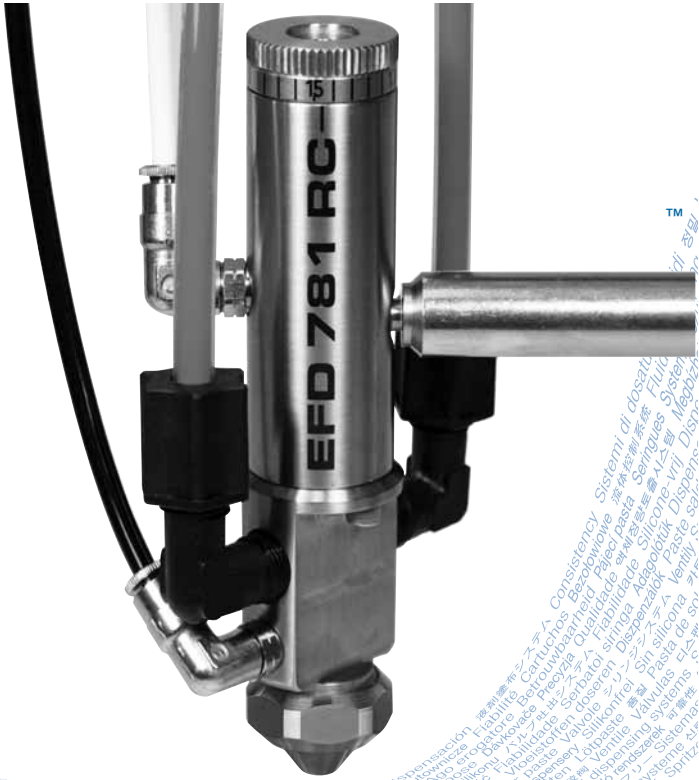

781RC Recirculation Pump Marking System Operating Manual



Contents

Safety.....	3
Specifications.....	6
Introduction	7
Setup Procedures.....	8-10
Initial Startup Procedures After Downtime	11
Maintenance & Cleaning	12-14
Troubleshooting Guide	15
Replacement Parts.....	16
Warranty	Back Cover

This manual is for the express and sole use of EFD purchasers and users, and no portion of this manual may be reproduced in any form.

Safety Warnings

Equipment Misuse Hazard

GENERAL SAFETY – Any use of the reservoir and related accessories not consistent with that described in this manual, such as modifying or removing parts, over-pressurizing, using incompatible fluids and chemicals, or using worn, damaged or incompatible parts can cause them to rupture resulting in serious bodily injury, including fluid splashed in the eyes or on the skin, or fire, explosion or other property damage. NEVER alter or modify any part of this equipment, as doing so may cause it to malfunction. CHECK all system components regularly and replace any worn or damaged parts with only EFD supplied or approved parts. BE SURE that all dispensing equipment and accessories are rated to withstand the maximum operating pressure of the reservoir.

Personal Protective Equipment

Wear all protective eyewear, gloves, clothing and respirator as recommended by the manufacturer of the fluid used.

Fluid Compatibility

BE SURE that all fluids, including their vapors, contained in the reservoir are compatible with all materials on the wetted materials list on page 6 of this manual. Read the fluid manufacturer's literature, including the MSDS (Material Safety Data Sheet) and observe all warnings before pouring the fluid into the reservoir.

Fill Level

DO NOT overfill the reservoir. The recommended maximum fill level is 38.1 mm (1.5") below the top of the liner.

User's Responsibility

It is the responsibility of the user to ensure the 781RC system is installed in a manner that complies with all local and national jurisdictional requirements.

Safety Warnings

Tipping and Dropping Hazard

BE SURE that the reservoir is placed on a hard, level surface and that all tubing lengths are of sufficient length to allow free motion of all movable components attached to the reservoir. DO NOT pull on tubing to move the reservoir. Tipping the reservoir or otherwise supporting it on its side can cause the system to run dry resulting in possible pump damage.

If any system component parts are damaged or worn, they must be replaced with EFD supplied or approved parts before returning to service.

Tubing Safety

Pressurized tubing can be very dangerous. Tubing whose integrity is compromised due to any kind of wear, damage or misuse can develop a leak, spraying the contents of the tank at high pressure. This spray can enter the eyes or cover the skin or cause other serious bodily injury, fire or property damage. Before pressurizing the reservoir:

1. BE SURE all fluid connections to the reservoir and pump are properly secured.
2. Examine all tubing for cuts, wear, bulges and leaks. If any of these conditions exist, replace the tubing immediately with EFD supplied or approved tubing. Do not try to repair a damaged tube.
3. BE SURE that the fluid to be dispensed is compatible with the tubing. Contact the fluid manufacturer and confirm that the fluid is compatible with the tubing material specified on page 16 of this manual.
4. BE SURE that the fluid to be dispensed is compatible with the tubing. Contact the fluid manufacturer and confirm that the fluid is compatible with the polyethylene tubing supplied.*

* Use only EFD supplied polyethylene tubing for applications that use solvent based liquids.

Preventative Maintenance

As part of maintaining continuous trouble-free use of this product, EFD recommends a few very simple preventative maintenance checks.

1. Periodically inspect tube to fitting connections for proper fit. Secure as necessary.
2. Check tubing for cracks and contamination. Replace tubing as necessary.
3. Check all wiring connections for looseness. Tighten as necessary.
4. If front panel of 8040 controller requires cleaning, use a clean, soft damp rag with a mild detergent cleaner. DO NOT USE strong solvents (acetone, MEK, etc.) as they will damage the front panel material.
5. Dry running time should be kept to a minimum – less than 5 minutes.
6. During initial pump startup and priming, pump speed should be kept low until fluid reaches the pump. Once primed, pump speed can be increased.



Turn off pump enclosure assembly before servicing any 781RC recirculating system components.



RoHS标准相关声明 (China RoHS Hazardous Material Declaration)

产品名称 Part Name	有害物质及元素 Toxic or Hazardous Substances and Elements					
	铅 Lead (Pb)	汞 Mercury (Hg)	镉 Cadmium (Cd)	六价铬 Hexavalent Chromium (Cr6)	多溴联苯 Polybrominated Biphenyls (PBB)	多溴联苯醚 Polybrominated Diphenyl Ethers (PBDE)
外部接口 External Electrical Connectors	X	0	0	0	0	0
<p>0: 表示该产品所含有的危险成分或有害物质含量依照EIP-A, EIP-B, EIP-C的标准低于SJ/T11363-2006 限定要求。 Indicates that this toxic or hazardous substance contained in all the homogeneous materials for this part, according to EIP-A, EIP-B, EIP-C is below the limit requirement in SJ/T11363-2006.</p> <p>X: 表示该产品所含有的危险成分或有害物质含量依照EIP-A, EIP-B, EIP-C的标准高于SJ/T11363-2006 限定要求。 Indicates that this toxic or hazardous substance contained in all the homogeneous materials for this part, according to EIP-A, EIP-B, EIP-C is above the limit requirement in SJ/T11363-2006.</p>						

Specifications

ENCLOSURE

Cabinet Size (Length x Width x Depth):	25.4 cm x 20.3 cm x 10.2 cm (10.00" x 8.00" x 4.00")
Weight:	6.5 kg (14 lbs 6 oz)
Input AC (to power supply):	100-240 VAC ~ – 50/60 Hz
Output Voltage (from power supply):	24 VDC – 2.7 Amp maximum
Power Requirements:	24 VDC – 2.0 Amp maximum
Ambient operating conditions:	Temperature: 5°C to 45°C (41°F to 113°F) Humidity: 85% RH at 30°C non-condensing Height above sea level: 2000 meters max (6,562 feet)
NEMA Rating	Type 12 and 13

PUMP

Flow Capacity:	Up to 88 liters per hour
Weight:	0.385 kg (13.6 oz)
Dimensions (Length x Max Diameter):	130.5 mm x 56 mm (5.140" x 2.20")
Power Input:	24VDC – 2 Amps maximum
Wetted Materials*:	Pump body: 303SS Gears: PEEK Gasket: PTFE
Speed Control Signal:	0-10 volts DC
Pump Drive:	Magnetic Coupling

*Refer to Specifications Page in 781S Installation Guide for reference to wetted materials.

Note: Specifications and technical details are subject to engineering changes without prior notification.

Introduction

How the system operates

The 781RC Recirculation System was designed specifically to deal with pigmented inks and similar liquids that have a tendency for solids within them to settle out of solution. The main concern with settling is that the solids tend to clog the output of the spray valve, especially at low flow settings. The 781RC system prevents clogging and allows the user to set the valve to low flow values.

Unlike many other spray valve systems, the 781RC Recirculation System does not use compressed air to create system pressure and flow. Instead, it uses a gear pump driven by a brushless direct current electric motor. The motion of the gear pump keeps the ink mixed, and since it is a positive displacement pump, the liquid is constantly moving. The flow in the system is controlled by the speed of the motor, which is adjusted by a potentiometer within the pump enclosure. The internal flow path geometry within the 781RC spray valve helps to prevent settling as well. When the valve is not spraying, the flow path in the fluid body keeps the liquid from stopping within the valve. Lastly, the return line is oriented within the reservoir to promote mixing and prevent settling.

Before You Begin – Power Input Options

Electrical connection options for pump enclosure assembly

+24 volt DC input for direct wiring of Pump Enclosure from a factory supplied 24 volt bus. Screw type connection terminal block.

Ground connection from the 24 volt bus.

External power supply input connector for universal power supply kit # 7013911.

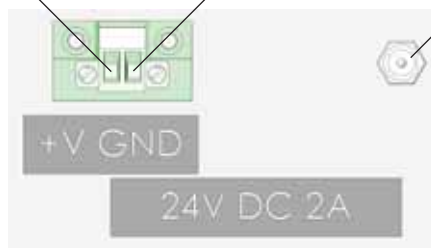

Setup

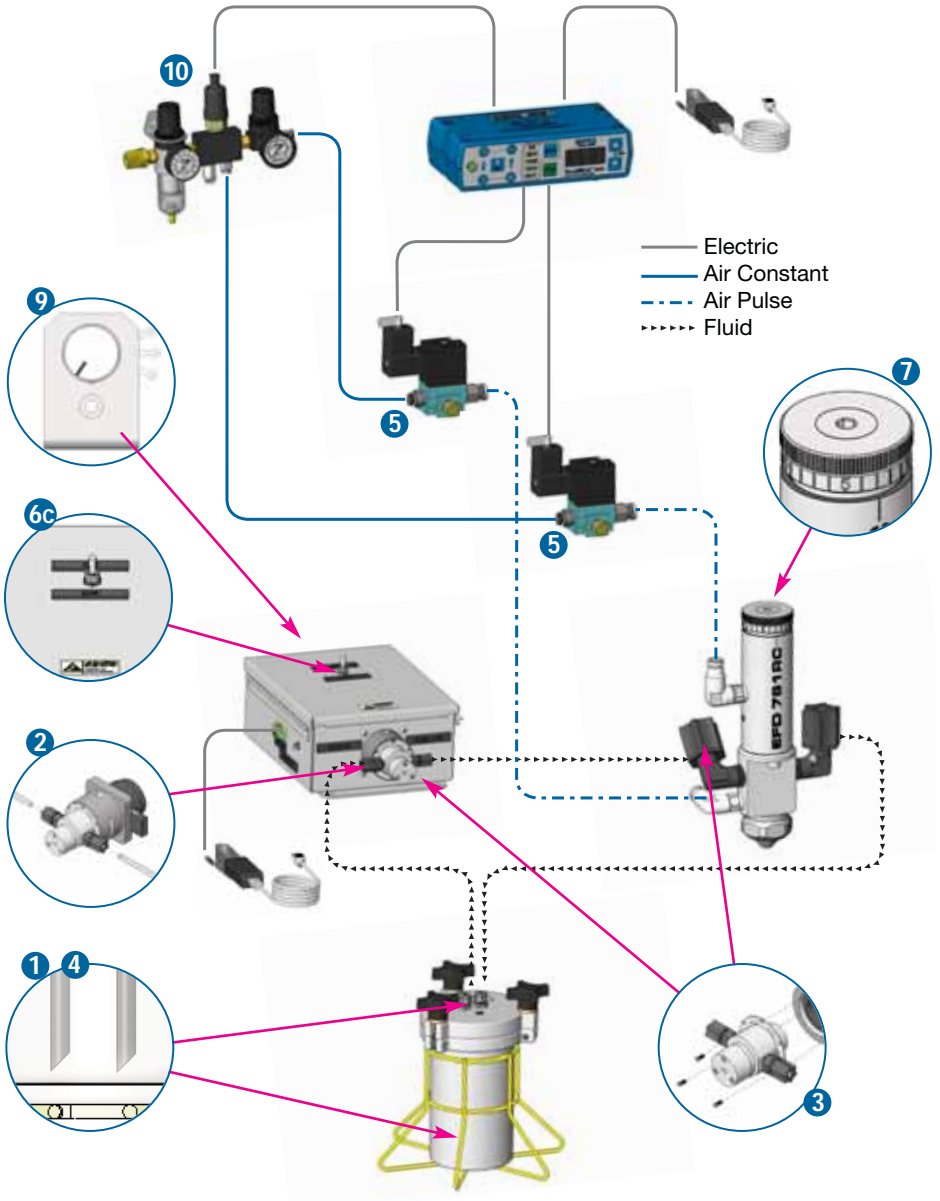

Initial 781RC Installation/Setup Procedures

Prior to installing this system, please read the associated spray valve and valve controller operating instructions to become familiar with the operation of all components of the spray system. Select appropriate system setup location for all system components – Pump Enclosure Assembly, 1-liter reservoir, ValveMate 8040, and 781RC Spray Valve.

Important Note: Turn pump enclosure power switch to OFF and insure speed control is turned fully counter-clockwise to OFF position.

1. Cut feed tube hose to desired length and install into tank lid outlet port. Insert tube to bottom of tank liner. Cut tube at slight angle to avoid fluid blockage at bottom of tank.
2. Connect the fluid supply line from tank outlet to pump inlet compression fitting.
3. Connect the fluid line from pump outlet to the 781RC inlet port compression fitting.
4. Cut recirculation feed hose to desired length and install into tank lid recirculation port. Insert recirculation hose to bottom of 1-liter liner. Cut tube at slight angle to avoid fluid blockage at bottom of tank. Attach other end to 781RC recirculation port outlet compression fitting.
5. Connect the control air hose and the nozzle air hose to corresponding outputs on solenoid block. Reference ValveMate 8040 Quick Setup Guide.
6. Fill reservoir by pouring fluid directly into tank liner or manufacturer's bottle placed inside reservoir. Secure cover.
 - A. Confirm the speed control knob is OFF by turning fully counter-clockwise.
 - B. Set ValveMate 8040 to **PURGE** mode.
 - C. Turn Pump enclosure power switch to ON
7. Turn 781RC valve stroke to no less than 1/2 turn or more open.

Priming the pump. (Important Note: Dry running time should be kept to an absolute minimum.)

8. During initial startup/priming, keep pump speed LOW (approximately 9 o'clock position) until fluid reaches the pump and begins to recirculate to the 781RC Spray Valve. Increase pump speed after initial prime to accelerate recirculation.
(Note: Make changes to pump speed slowly to avoid surge loads on external power supply.)

Initial Installation Setup Procedures (contd.)

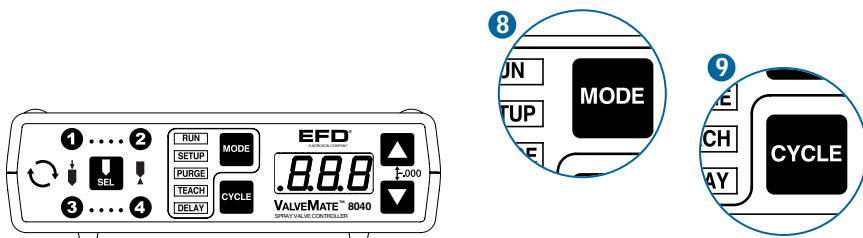

9. Once 781RC system is fully primed, set pump speed control to approximately 9 o'clock – 
10. Using the **MODE** button on the ValveMate controller, place the controller in the **PURGE** mode. In **PURGE** mode only, channels **1** and **3** can be selected independently without nozzle air pressure.
11. While in **PURGE** mode, depress **CYCLE** button and adjust speed control to set fluid flow rate to one or two drops per second.

Note: Flow adjustments should be made with speed control as opposed to reductions of valve needle stroke. Tight valve stroke settings will cause blockage/clogging of valve outlet.

12. Set the nozzle air pressure on the nozzle to 5 psi (0.7 bar) and actuate the controller. Adjust higher as needed to create even spray. The valve will produce a fine spray. To change fluid flow, use the needle stroke control knob and/or pump speed control. Maintain balanced settings. Do not set stroke too tightly as this will cause nozzle clogging.
 To change nozzle air, use the nozzle air pressure regulator. Higher pressures will provide finer spray.

Recirculation System Startup Procedures after prolonged periods of downtime

If factory regulations require system shutdown during evening and/or week-ends or after long periods of pump system shutdown, some settling may have occurred in your ink or paint.

Before starting to spray mark, it will be important to remix/agitate your fluid to return settled pigments back into solution.

To remix, follow these simple procedures

1. Make certain pump is SHUT OFF.
2. Remove lid from reservoir and stir contents in liner until thoroughly mixed. Replace lid.
3. Open pump box to access internal speed control. (Make notation of speed control setting to return to this position after remix/agitation procedure.)
4. Slowly turn Speed Control clockwise to the 2 o'clock – 3 o'clock position. This will dramatically increase flow volume.
5. Close pump box cover and turn pump ON.
6. Let fluid recirculate for 1-2 minutes. This should provide ample recirculation of fluid in feed lines and spray valve.

*** Important note: Do not cycle test the spray valve at this high flow condition as this will result in excessive spray mark volume!!!**

7. Shut OFF pump. Open pump box cover and return Speed Control to original cycle setting – about 9 o'clock  position is sufficient if prior setting unknown.
8. Close pump cover. Turn pump ON.
9. Cycle test 781RC spray valve until desired spray mark occurs.

Maintenance and Cleaning

General Cleaning

1. Remove fluid filled container and replace with new liner.
2. Pour appropriate solvent / cleaner into new liner. Increase pump speed control setting and valve stroke to increase fluid flow. Circulate solvent through system. Note: Select channel 1 or 3 for nozzle air OFF operation during initial cleaning cycle.
3. After a few minutes of circulation, place container under valve and purge solvent from 781RC valve until tank runs nearly dry.
4. Repeat process with fresh solvent to clean system completely.
5. System should now be ready for next spray process.

Disposal of Discarded Wetted Materials

The user should consult local jurisdictional requirements for the proper disposal of all discarded material.

Maintenance and Cleaning (contd.)

Pump Maintenance and Cleaning (Fluid Side)

1. Disconnect electrical power from enclosure.



2. Remove tubing from pump fittings.



3. Remove pump from motor housing by removing the 3 mounting screws.



4. Remove 3 long screws from front of pump housing to disassemble wetted components of pump.

5. Inspect PEEK gears and PTFE gaskets for wear / damage. Replace as necessary using p/n 7014378* Pump Rebuild service kit.

6. Clean any surfaces / orifices of fluid residues.

7. Reassemble in reverse order of disassembly.

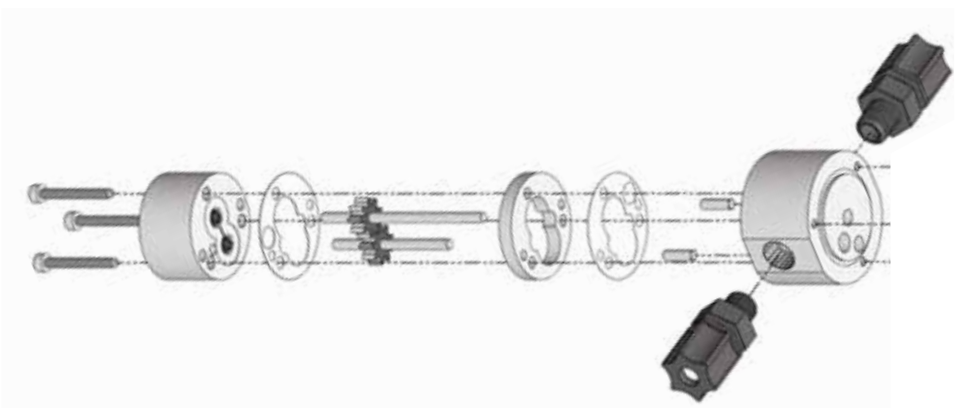

Pump Cleaning (Motor Drive Side)

If cleaning of fluid side is insufficient to prevent binding of pump, then disassemble drive side following these steps below:

1. Remove 3 small screws from rear of pump housing.
2. Remove mounting ring and drive housing.
3. Clean all wetted surfaces and reassemble.
4. Reattach pump to motor housing.

Valve Cleaning

Refer to 781S Series Spray Valve Maintenance and Parts Guide for valve disassembly and reassembly procedures.

* Includes PTFE gaskets, PEEK gears/ss shafts and bushings.

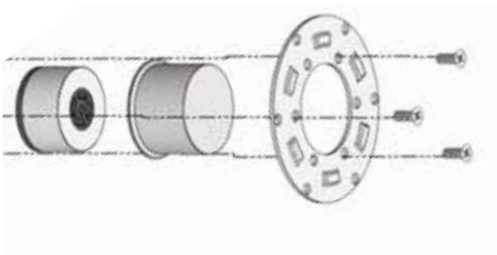

Troubleshooting Guide

Trouble

Solution

Motor does not run.

Check ON/OFF and power connections.

Pump operating but produces no flow.

Check tank fluid level. If empty, fill. If tank fill level okay, check for fluid line/pump system blockages.

Fluid leaks from pump housing.

Check pump housing screws are tight. Inspect gasket for damage.

Pump binding while motor is turning.

Clean pump per Pump Maintenance/Cleaning Instructions.

Fluid is not spraying from valve.

Check if pump speed control is OFF or set too low. If okay, check if valve outlet is clogged.

Replacement Parts

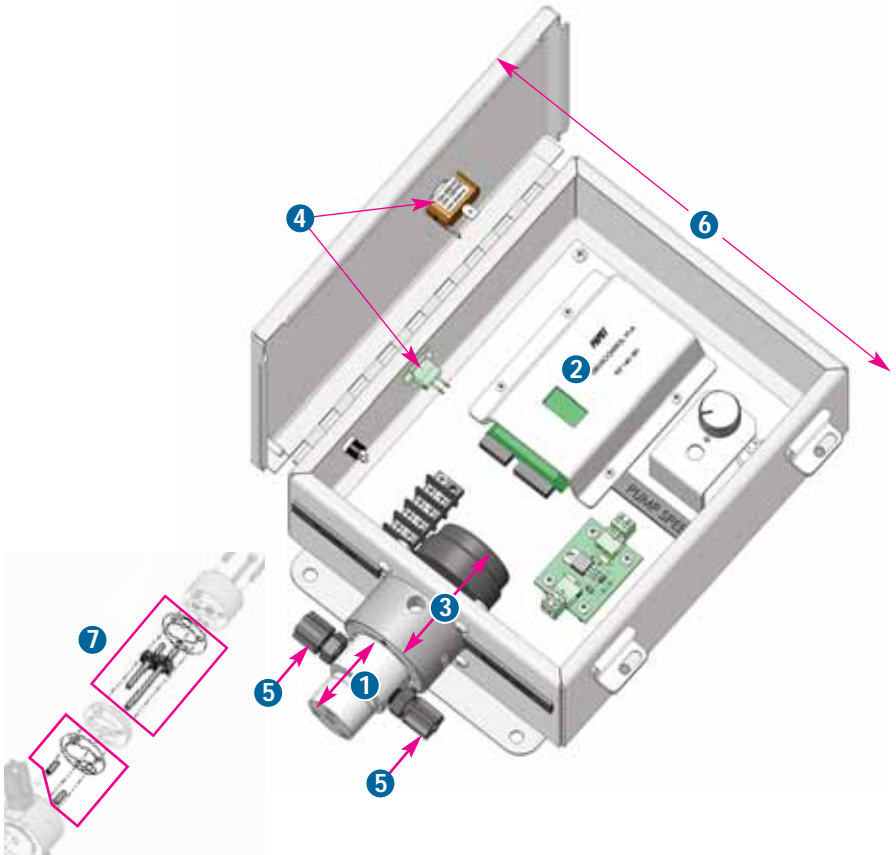

1. Part # 7013908 Pump kit, 781RC system
2. Part # 7013912 Brushless dc motor controller, 781RC system
3. Part # 7013909 Pump motor kit, 781RC system
4. Part # 7013914 Panel kit, pump box, 781RC system
5. Part # 7013910 Pump fitting kit, 781RC system
6. Part # 7014307 Pump enclosure assembly – complete
7. Part # 7014378 Pump rebuild service kit
8. Part # 7013565 1 liter tank, recirculating system – not shown
9. Part # 7012744 781RC-SS spray valve .014 – not shown
10. Part # 7012745 781RC-SS spray valve .028 – not shown
11. Part # 7013911 External power supply kit, 781RC system – not shown

EFD ONE YEAR LIMITED WARRANTY

All components of the EFD 781RC Recirculation Pump System are warranted for one year from date of purchase to be free from defects in material and workmanship (but not against damage caused by misuse, abrasion, corrosion, negligence, accident, faulty installation or by dispensing material incompatible with equipment) when the equipment is installed and operated in accordance with factory recommendations and instructions. EFD will repair or replace free of charge any part of the equipment thus found to be defective, on authorized return of the part prepaid to our factory during the warranty period.

In no event shall any liability or obligation of EFD arising from this warranty exceed the purchase price of the equipment. This warranty is valid only when oil-free, clean, dry, filtered air is used.

EFD makes no warranty of merchantability or fitness for a particular purpose. In no event shall EFD be liable for incidental or consequential damages. This equipment is regulated by the European Union under WEEE Directive (2002/96/EC).

See www.efd-inc.com for information about how to properly dispose of this equipment.



For EFD sales and service in over 30 countries,
contact EFD or go to www.efd-inc.com

EFD, Inc.

East Providence, RI USA
USA & Canada: 800-556-3484; +1-401-431-7000
info@efd-inc.com www.efd-inc.com

EFD International Inc.

Dunstable, Bedfordshire, UK
0800 585733 or +44 (0) 1582 666334
Ireland 00800 8272 9444
europe@efd-inc.com www.efd-inc.com

EFD, Inc., Asia

China: +86 (21) 3866 9006
china@efd-inc.com www.efd-inc.com
Singapore: +65 6796 9630 sin-mal@efd-inc.com

The Wave Design is a trademark of Nordson Corporation.
©2009 Nordson Corporation 781RC-MAN-01 7014319 v030609



This equipment is regulated by the European Union under WEEE Directive (2002/96/EC). See www.efd-inc.com for information about how to properly dispose of this equipment.