

750 Series Dispense Valve INSTALLATION GUIDE

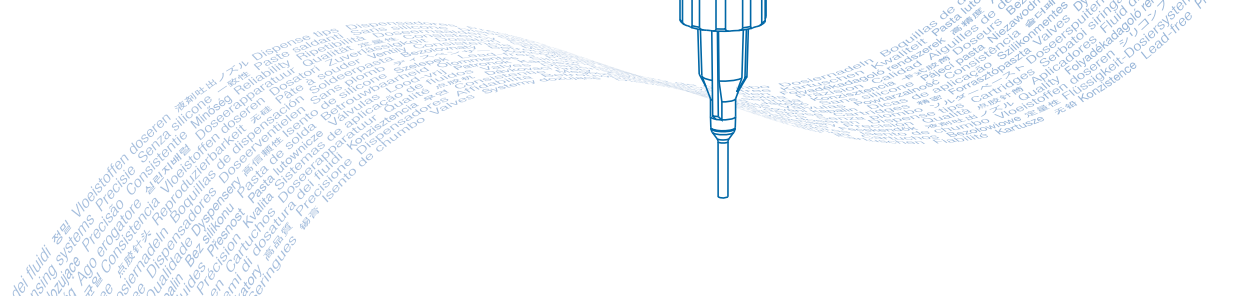

Electronic pdf files of EFD manuals are also available at www.efd-inc.com/manuals.html.

USA & Canada: 800-556-3484 or +1-401-434-1680
 Europe: 0800 585733 or +44 (0) 1582 666334
 Asia: +86 (21) 5854 2345
technical@efd-inc.com www.efd-inc.com

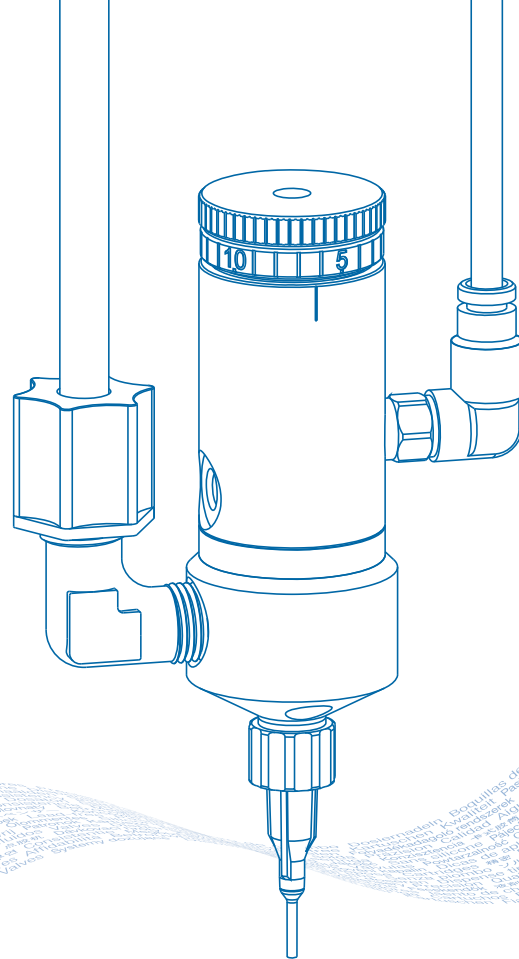

Introduction

The 750 Series fluid dispense valves are simple to use and will operate many millions of cycles without maintenance. The 750 Series incorporates a variety of compact, precise, adjustable diaphragm valves for dispensing low to medium viscosity fluids. These include the 750V, 750V-SS, 751V, 752V, 752V-SS, 752V-UH, 752V-UHSS, 752V-DVD and 752V-UHDVD models.

All 750 Series valves use the same actuating assembly. But fluid body styles and diaphragms differ according to the model. The 752V Series fluid bodies are constructed with the outlet at the end of the fluid body. The 750V and 751V fluid bodies are constructed with the outlet on the side of the fluid body.

Each valve is shipped with a dispensing tip adapter, fluid inlet fitting and 5-foot actuating air hose installed.

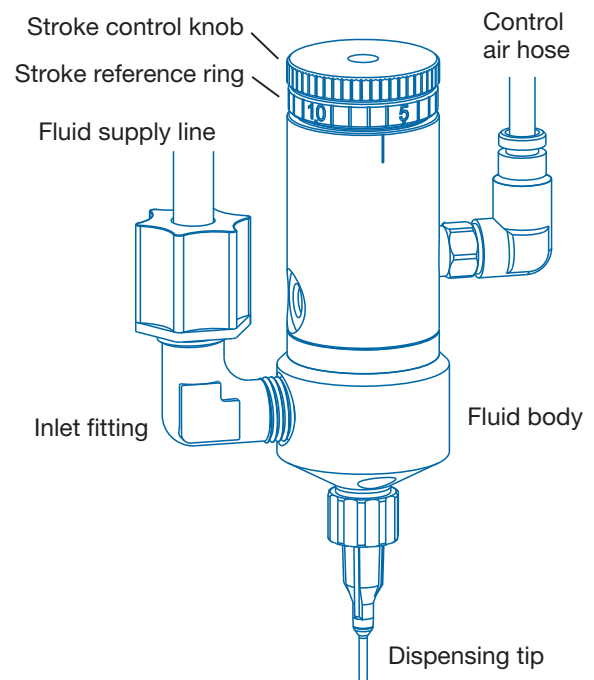

Installation

Prior to installing this valve, please read the associated reservoir and valve controller operating instructions to become familiar with the operation of all components of the dispensing system.

1. Connect fluid supply line to valve. If 3/8" OD tubing is used, change to fitting #7610BP supplied.
2. Connect the fluid supply line to reservoir. The reservoir can accept either 1/4" OD or 3/8" OD tubing using #62518PT supplied.

3. Connect valve control air hose to ValveMate™ 8000 (solenoid pack) used to control valve open time.
4. Choose a dispensing tip—small tips (20 gauge) for low-viscosity fluids and larger (14 gauge) for higher viscosities.
5. Fill reservoir by pouring fluid directly into tank liner or manufacturer's bottle placed inside reservoir. Secure cover prior to setting pressure.
6. Set reservoir pressure to low for thin fluids and higher for thick fluids.

7. Set the diaphragm stroke starting with no more than 1/2 turn open.*
8. Place a cup under the dispensing tip and actuate the valve until fluid lines, valve and dispensing tip are free of air.
9. Set desired flow rate by adjusting fluid reservoir pressure or changing dispensing tip.

* Do not overtighten the stroke adjustment knob or open it more than two full turns. If open more than two turns, pressurized liquid could force open the diaphragm seal, resulting in continuous liquid flow.

Important Note: Set desired deposit size by adjusting valve open time. Refer to valve controller operating manual.

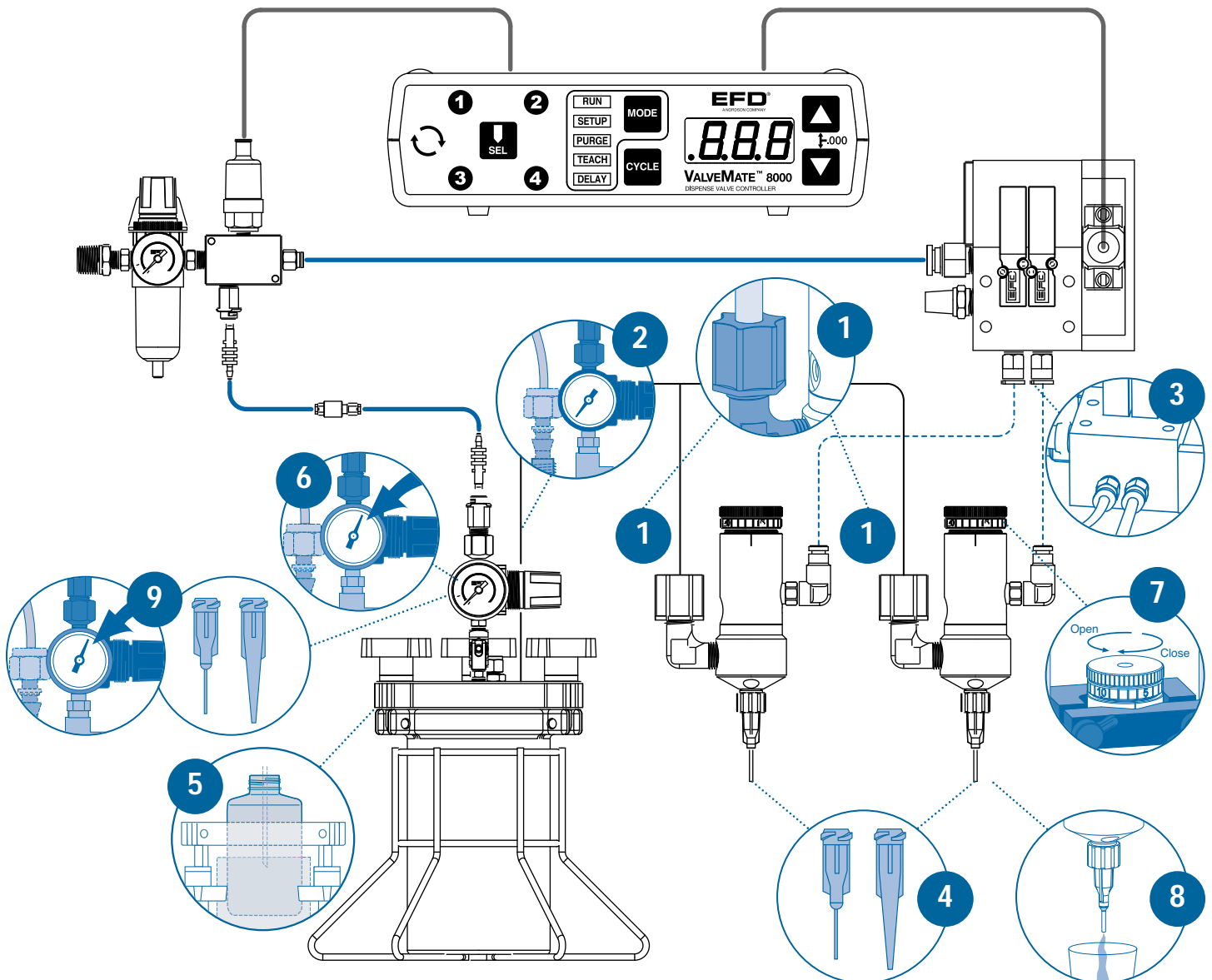

How the Valve Operates

Input air pressure at 70 psi (4.8 bar) forces the internal piston ① to move. ② The piston rod pulls open the diaphragm seal, ③ permitting fluid flow. When the input air pressure is relieved, the spring retracts the piston and the diaphragm closes.

The amount of fluid dispensed will depend on the time the valve is open, the viscosity of the fluid, the air pressure in the fluid reservoir, the dispensing tip size and the diaphragm stroke.

Flow rate is a function of reservoir pressure, tip size and fluid viscosity.

To calibrate the valve, the "0" mark on the stroke reference ring should align with one of the two reference marks on the valve body. When the set-screw is tightened, the valve is calibrated.

The primary control of deposit size is the valve open time.

752V and 752V-UH Fluid Flow

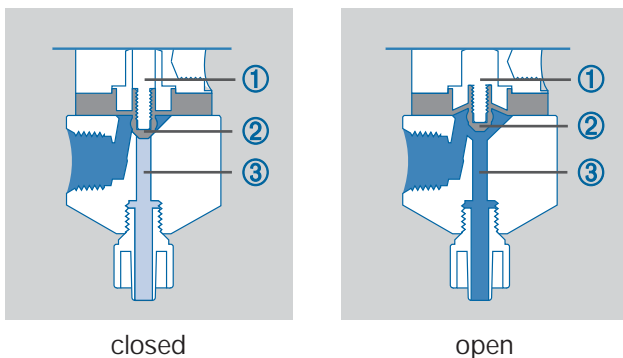

750V and 751V Fluid Flow

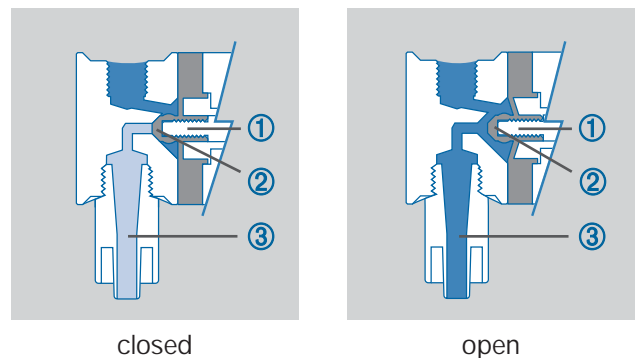

ValveMate Concept

The ValveMate 8000 provides easy adjustment of valve output for maximum end-user convenience and efficiency. Valve open time is the primary control of deposit. The 8000 puts push-button adjustment of valve open time where it needs to be—at the valve.

The ValveMate 8000 features micro-processor circuitry for extremely precise control of deposit size. Feed lines can be purged, initial deposit sizes set, and adjustments made quickly and easily at the dispensing station, without stopping the production line.

Note: The EFD Ultra® TT 325 and 525 XYZ automated dispensing systems have integrated ValveMate controllers for operating all EFD dispense valves.

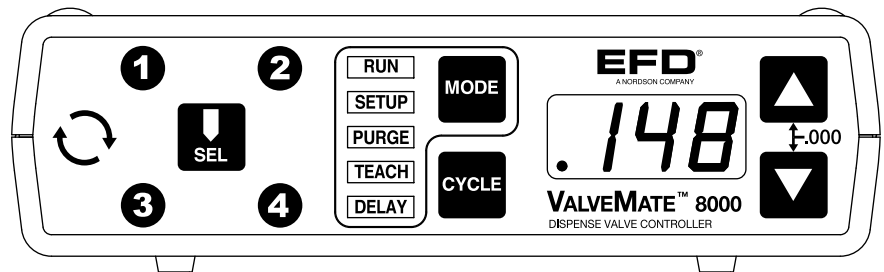

Important Note: Order your 1, 2, 3 or 4 solenoid manifold block assembly separately. Consult EFD for recommendations.

www.efd-inc.com technical@efd-inc.com USA & Canada 800-556-3484 Europe +44 (0) 1582 666334 Asia +86 (21) 5854 2345



Specifications

General

Diaphragm: UHMW* polyethylene
Air pressure required: 70 to 90 psi (4.8 to 6.2 bar)
Maximum fluid pressure: 70 psi (4.8 bar)
Maximum operating temperature: 43°C (110°F)
Mounting: (1) 10-32 UNF tapped hole

750V and 750V-SS

Size: 64.7 mm length x 23.8 mm diameter
(2.55" x 0.94")
Weight: 750V – 93.5 grams (3.30 oz)
750V-SS – 165.8 grams (5.85 oz)
Air cylinder body: 750V – Hard-coated aluminum
750V-SS – Type 303 stainless steel
Fluid body: UHMW* polyethylene
Free flow orifice: 1.57 mm diameter (0.062")
Fluid inlet thread: 1/4-28 UNF
Output thread: 5/16-28 UNF
Tip adapter: Polypropylene

751V

Size: 64.7 mm length x 26.9 mm diameter
(2.55" x 1.06")
Weight: 101.7 grams (3.59 oz)
Air cylinder body: Hard-coated aluminum
Fluid body: Acetal copolymer
Free flow orifice: 2.03 mm diameter (0.08")
Fluid inlet thread: 1/8 NPT female
Output thread: 1/8 NPT female
Tip adapter: Nylon

* Ultra High Molecular Weight

752V, 752V-UH/752V-SS and 752V-UHSS

Size: 80.7 mm length x 26.9 mm diameter
(3.18" x 1.06")
Weight: 752V and 752V-UH – 99.5 grams (3.51 oz)
752V-SS and 752V-UHSS – 181.9 grams
(6.42 oz)
Air cylinder body: 752V and 752V-UH – Hard-coated aluminum. 752V-SS and 752V-UHSS – Type 303 stainless steel
Fluid body: 752V and 752V-SS – Acetal copolymer
752V-UH and 752V-UHSS – UHMW* polyethylene
Free flow orifice: 2.5 mm diameter (0.10")
Fluid inlet thread: 1/8 NPT female
Output thread: 1/4-28 UNF
Tip adapter: Polypropylene

752V-DVD and 752V-UHDVD

Size: 80.7 mm length x 26.9 mm diameter
(3.18" x 1.06")
Weight: 752V-DVD – 172.9 grams (6.1 oz)
752V-UHDVD – 99.5 grams (3.51 oz)
Air cylinder body: Type 303 stainless steel
Fluid body: 752V-DVD – Type 303 stainless steel
752V-UHDVD – UHMW* polyethylene
Free flow orifice: 2.5 mm diameter (0.10")
Fluid inlet thread: 1/8 NPT female
Output thread: 1/4-28 UNF 752V-UHDVD
752V-DVD (not applicable)
Tip adapter: 752V-DVD – Aluminum
752V-UHDVD – Polypropylene



For EFD sales and service in over 30 countries, contact EFD or go to www.efd-inc.com/contact

EFD, Inc.
East Providence, RI USA
USA & Canada: 800-556-3484; +1-401-434-1680
info@efd-inc.com www.efd-inc.com

EFD International Inc.
Dunstable, Bedfordshire, UK
0800 585733 or +44 (0) 1582 666334
Ireland 00800 8272 9444
europe@efd-inc.com www.efd-inc.com

EFD, Inc., Asia
China: +86 (21) 5854 2345
china@efd-inc.com www.efd-inc.com/cn
Singapore: +65 6896 9630 sin-mal@efd-inc.com

For consistent dispense valve operation and easy adjustment of valve output, EFD recommends using the ValveMate 8000 controller on all automatic, semi-automatic and benchtop applications.

The EFD Ultra TT Series positioning systems incorporate dispensing control into the main system.

Contact the EFD Dispense Valve Systems Group for details.