

741V Series Dispense Valve

INSTALLATION GUIDE



Electronic pdf files of EFD manuals are also available at www.efd-inc.com/manuals.html.

USA & Canada: 800-556-3484 or +1-401-434-1680
 Europe: 0800 585733 or +44 (0) 1582 666334
 Asia: +86 (21) 5854 2345
technical@efd-inc.com www.efd-inc.com

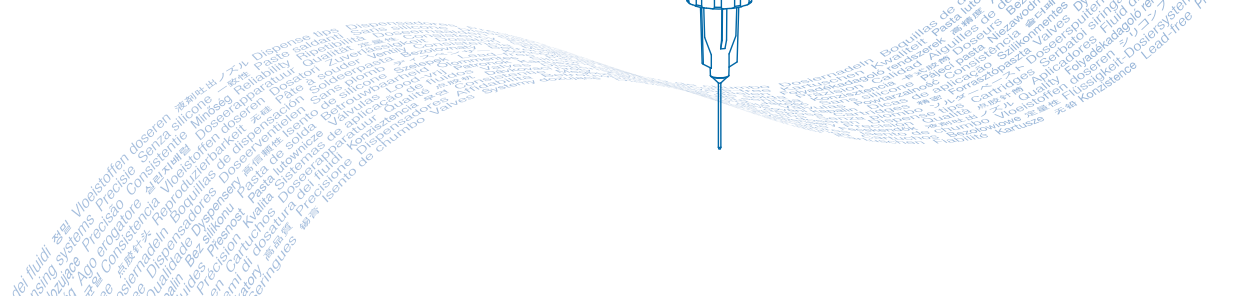
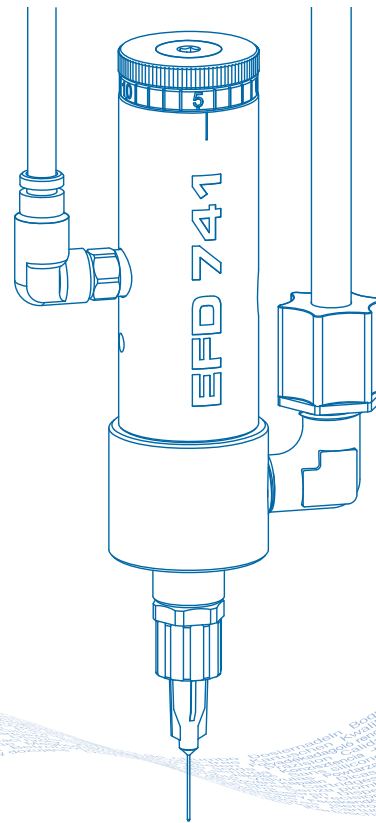

Introduction

The 741V Series dispense valve is simple to use and will operate many millions of cycles without maintenance.

The 741V Series valves are designed to apply low-viscosity fluids with accurate, extremely close repeat deposit control. The 741V and 741V-SS valves are ideal for use on automatic assembly machines.

Each valve comes equipped with a 5-foot actuating air hose and male quick-connect, adjustable stroke control and fluid inlet fitting. The dispensing tip adapter features a SafetyLok™ collar for secure dispensing tip attachment.

The 741V fluid body and air cylinder body are hard-coated aluminum. The 741V-SS valve model has a Type 303 stainless steel fluid body and air cylinder body.

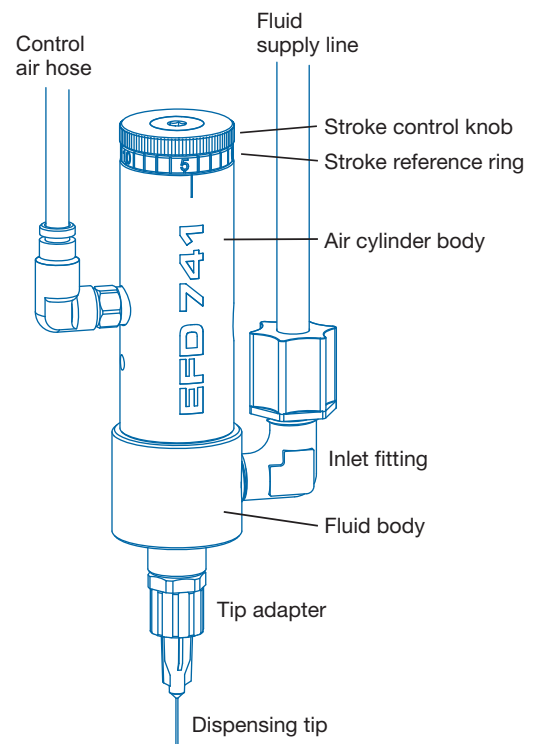

Installation

Prior to installing this valve, please read the associated reservoir and valve controller operating instructions to become familiar with the operation of all components of the dispensing system.

1. Connect fluid supply line to valve. If 3/8" OD tubing is used, change to fitting #7610BP supplied.
2. Connect the fluid supply line to reservoir. The reservoir can accept either 1/4" OD or 3/8" OD tubing using #62518PT supplied.
3. Connect valve control air hose to ValveMate™ 8000 (solenoid pack) used to control valve open time.
4. Choose a dispensing tip—small tips (20 gauge) for low-viscosity fluids and larger (14 gauge) for higher viscosities.
5. Fill reservoir by pouring fluid directly into tank liner or manufacturer's bottle placed inside reservoir. Secure cover prior to setting pressure.
6. Set reservoir pressure to low for thin fluids and higher for thick fluids.
7. Set the needle stroke starting at one full turn open.*
8. Place a cup under the dispensing tip and actuate the valve until fluid lines, valve and dispensing tip are free of air.
9. Set desired flow rate by adjusting fluid reservoir pressure, changing dispensing tip, or adjusting stroke setting.

* Do not overtighten the stroke adjustment knob or open it more than four full turns.

Important Note: Set desired deposit size by adjusting valve open time. Refer to valve controller operating manual.

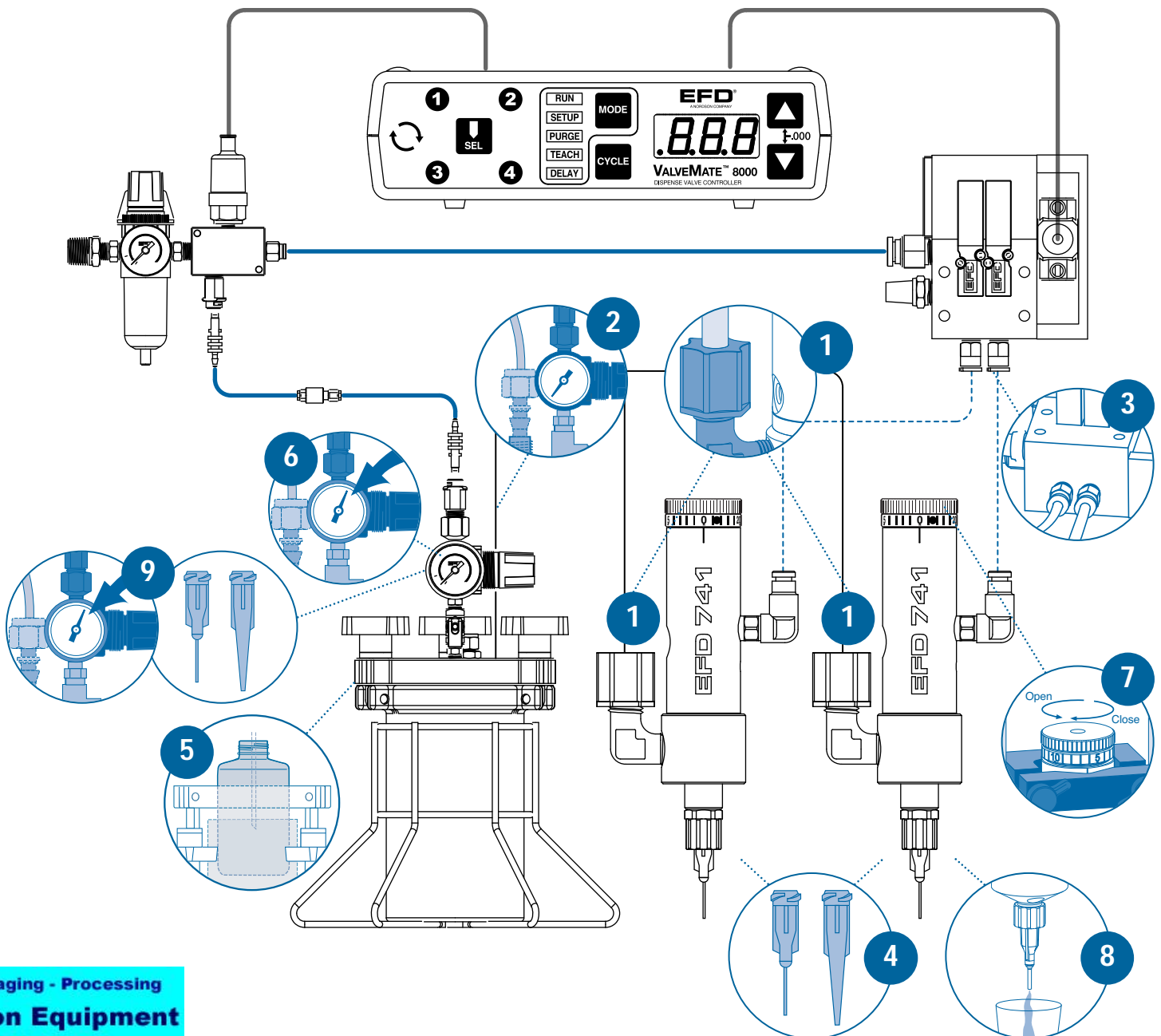

How the Valve Operates

Input air pressure at 70 psi (4.8 bar) retracts the needle ① from the needle seat ②, permitting fluid flow from the output tip adapter ③. Piston and needle stroke and fluid flow are controlled by the stroke control knob. Once the cycle is complete, air is exhausted back through the valve controller, ensuring rapid and positive fluid shutoff.

The 741V Series can be operated in any position without affecting flow. The amount of fluid dispensed will depend on the time the valve is open, fluid reservoir pressure, dispensing tip size, needle stroke and fluid viscosity.

To calibrate or document the dispensing process, use the stroke control reference. To calibrate, turn the calibrating adjustment (located in the end of the stroke adjustment knob) out two full turns. Close the stroke adjustment knob fully until it bottoms against the air cylinder body. Turn the adjustment until it stops, calibrating the valve to zero stroke.*

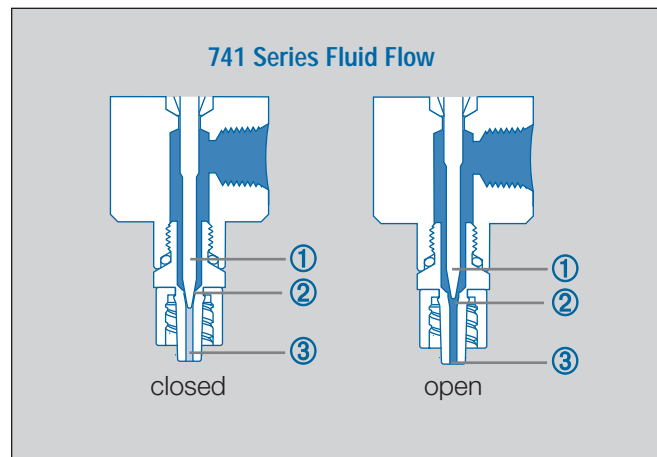

* The 741V valve can be ordered in a tamper-resist configuration to limit unauthorized adjustment. Specify part #741V-TR. For the stainless steel model, specify part #741V-SS-TR.

The primary control of deposit size is the valve open time.

ValveMate Concept

The ValveMate 8000 provides easy adjustment of valve output for maximum end-user convenience and efficiency. Valve open time is the primary control of deposit. The 8000 puts push-button adjustment of valve open time where it needs to be—at the valve.

The ValveMate 8000 features micro-processor circuitry for extremely precise control of deposit size. Feed lines can be purged, initial deposit sizes set, and adjustments made quickly and easily at the dispensing station, without stopping the production line.

Note: The EFD Ultra® TT 325 and 525 XYZ automated dispensing systems have integrated ValveMate controllers for operating all EFD dispense valves.

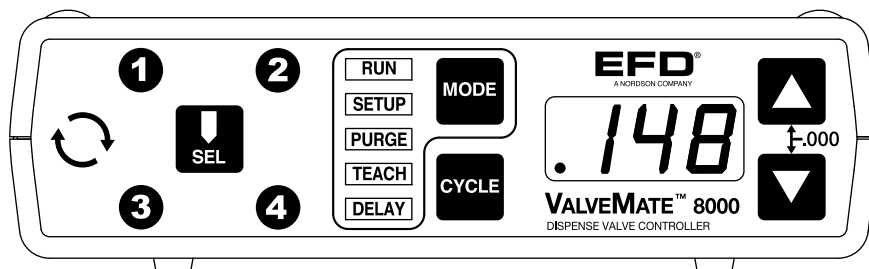

Important Note: Order your 1, 2, 3 or 4 solenoid manifold block assembly separately. Consult EFD for recommendations.

www.efd-inc.com technical@efd-inc.com USA 800-556-3484 Europe +44 (0) 1582 666334 Asia +86 (21) 5854 2345



741V Series Specifications

741V

Weight: 158.8 grams (5.6 oz)

Fluid body: Hard-coated aluminum

Air cylinder body: Hard-coated aluminum

741V-SS

Weight: 317.5 grams (11.2 oz)

Fluid body: Type 303 stainless steel

Air cylinder body: Type 303 stainless steel

General

Size: 114.6 mm x 26.9 mm diameter (4.51" length x 1.06")

Piston: Type 303 stainless steel

Needle: Type 303 stainless steel

Free flow orifice: 1.17 mm (0.046")

Fluid inlet thread: 1/8 NPT female

Fluid outlet: Male luer lock

Tip adapter/needle seat: Type 303 stainless steel

SafetyLok collar: Nylon

Needle packings: Teflon®

Air pressure required: 70 to 90 psi (4.8 to 6.2 bar)

Maximum input fluid pressure: 300 psi (20.7 bar)

Maximum operating temperature: 43°C (110°F)

Mounting: (1) 1/4-28 UNF tapped hole

Operating frequency: Exceeds 400 cycles/minute

Note: All stainless steel valve parts are passivated.

For consistent dispense valve operation and easy adjustment of valve output, EFD recommends using the ValveMate 8000 controller on all automatic, semi-automatic and benchtop applications.

The EFD Ultra TT Series positioning systems incorporate dispensing control into the main system.

Contact the EFD Dispense Valve Systems Group for details.



For EFD sales and service in over 30 countries,
contact EFD or go to www.efd-inc.com/contact

EFD, Inc.

East Providence, RI USA

USA & Canada: 800-556-3484; +1-401-434-1680

info@efd-inc.com

www.efd-inc.com

EFD International Inc.

Dunstable, Bedfordshire, UK

0800 585733 or +44 (0) 1582 666334

Ireland 00800 8272 9444

europa@efd-inc.com

www.efd-inc.com

EFD, Inc., Asia

China: +86 (21) 5854 2345

china@efd-inc.com

www.efd-inc.com/cn

Singapore: +65 6796 9630 sin-mal@efd-inc.com

Teflon is a registered trademark of DuPont.

©2007 Nordson Corporation 741V-INSTALL-01 v052107