

736HPA-NV High Pressure Dispense Valve

INSTALLATION GUIDE



Electronic pdf files of EFD manuals are also available at www.efd-inc.com

USA & Canada: 800-556-3484 or +1-401-434-1680
Europe: 0800 585733 or +44 (0) 1582 666334
Asia: +86 (21) 3866 9166
technical@efd-inc.com www.efd-inc.com

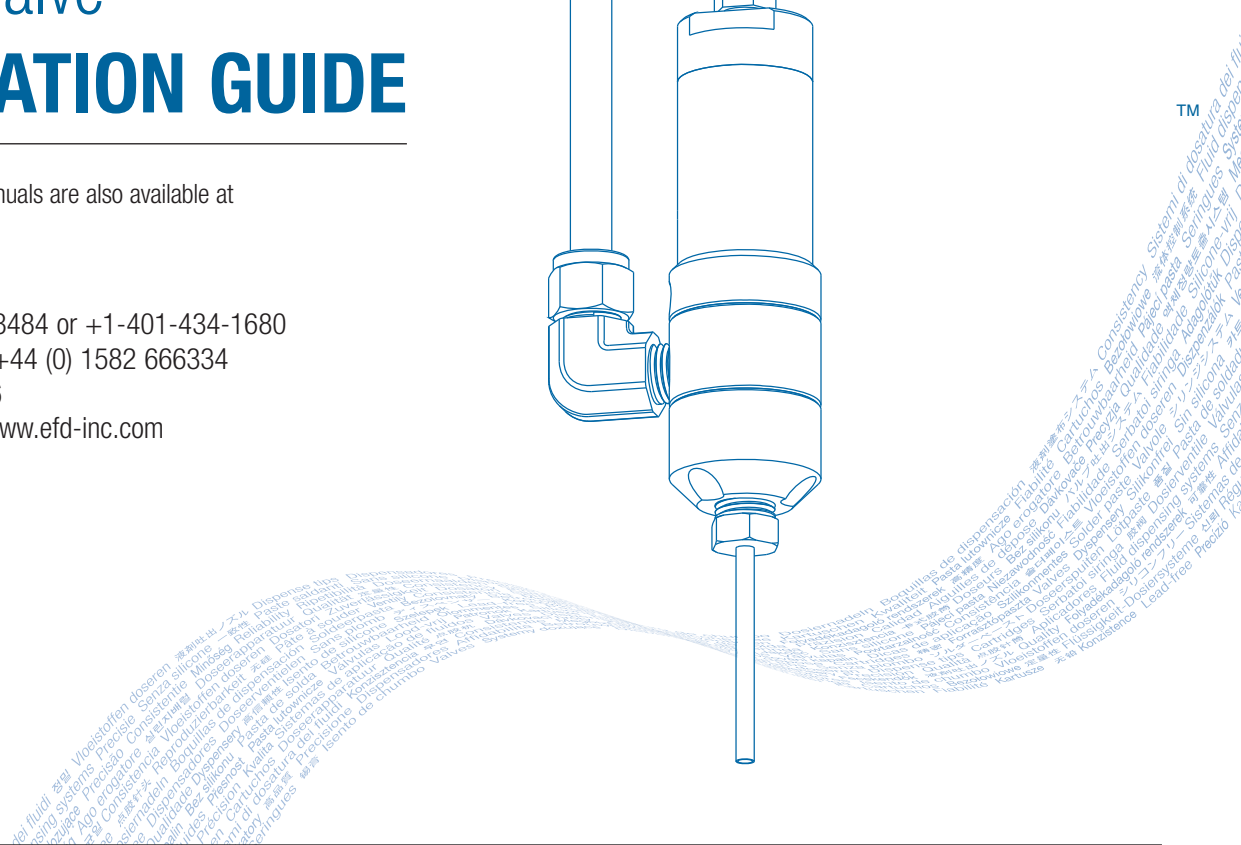
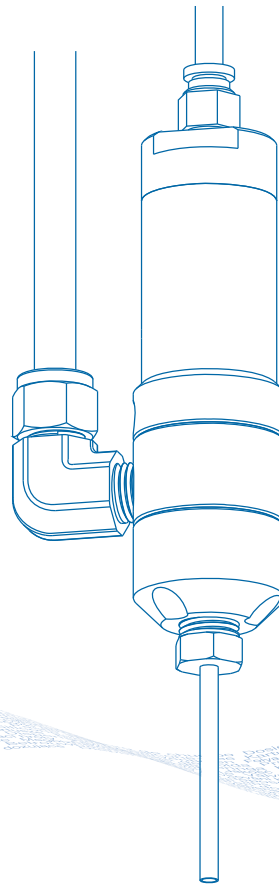

Introduction

The 736HPA-NV is a normally closed, air-actuated, balanced spool-type valve designed to operate at fluid pressures up to 2,500 psi (172 bar). Ideal for consistent dispensing of industrial sealants and greases, the 736HPA-NV valve is simple to use and will operate many millions of cycles without wear or leakage.

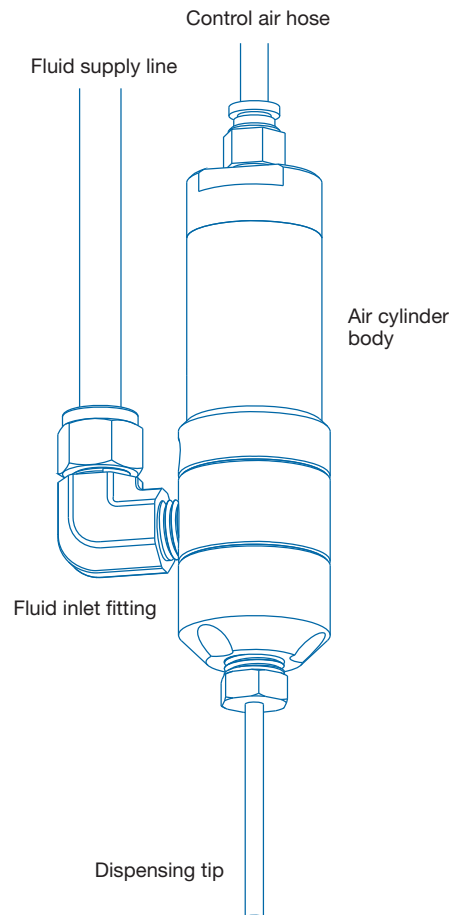

To order, request part number 7013449.

Installation

Prior to installing this valve, please read the associated reservoir and valve controller operating instructions to become familiar with the operation of all components of the dispensing system.

1. Thread the fluid inlet fitting into the fluid inlet hole. **Note:** The fluid inlet fitting and hose must be obtained from the high pressure pump supplier. Ensure that the hose and fitting are rated for the maximum operating pressure of the pump system.

2. Connect the fluid feed hose to the fitting.

3. Connect valve control air hose to ValveMate™ 8000 (solenoid pack) controller used to control valve open-time.

4. Install appropriate threaded nozzle to the valve output or use a dispensing tip adapter (#7016941) with EFD SafetyLok™ dispensing tips.

5. Check to be sure all fluid and air connections are tight.

6. Make sure valve operating pressure is set at 70 psi (4.8 bar).

7. Be sure delivery pump pressure does not exceed 2,500 psi (172 bar).

8. Place a cup under the dispensing tip or nozzle and actuate the valve until fluid flows steady.

9. Set desired flow rate by adjusting fluid pressure or changing the outlet tip size.

Important Note: Set desired deposit size by adjusting valve open time. Refer to valve controller operating manual.

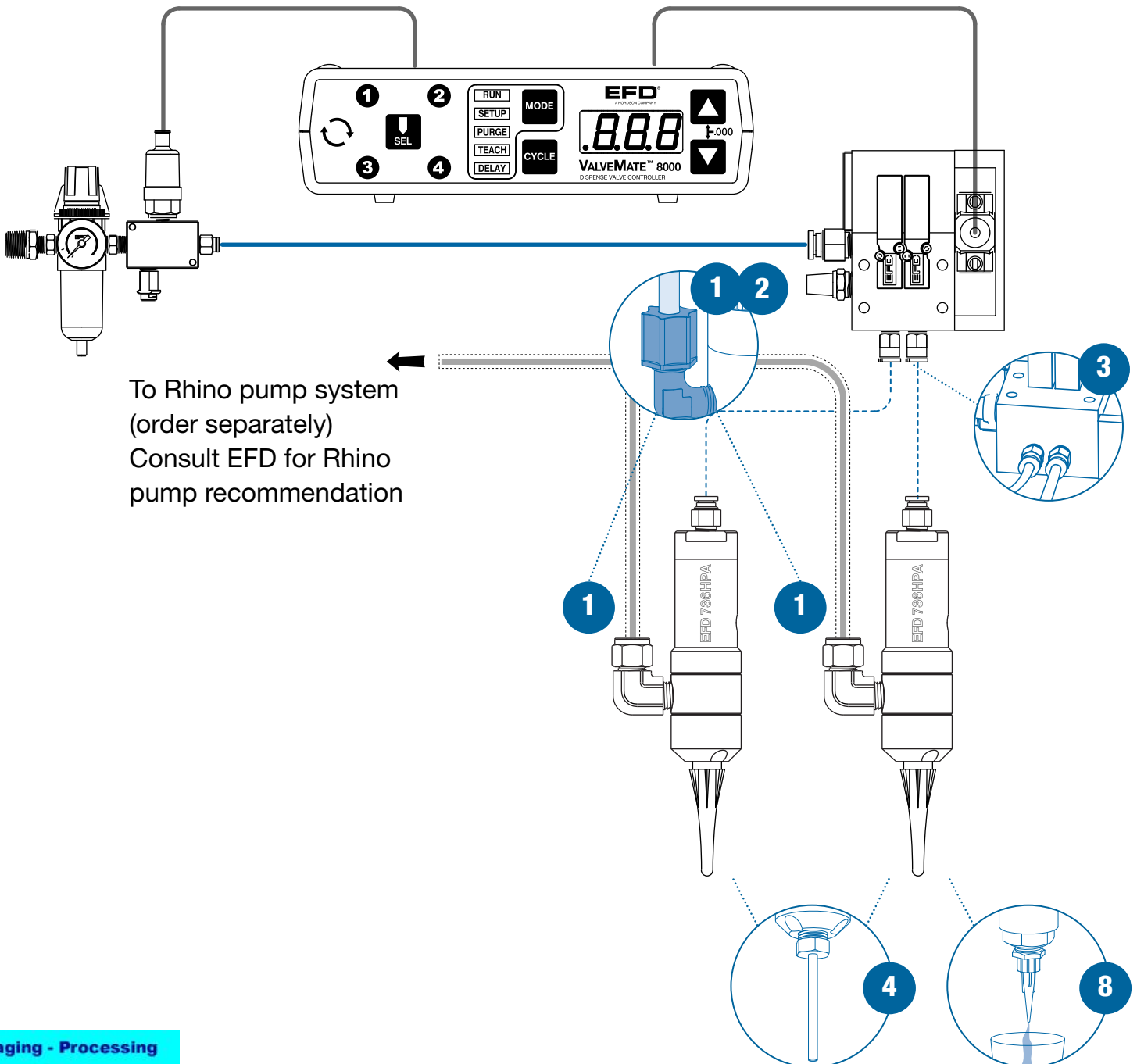

To Rhino pump system
(order separately)
Consult EFD for Rhino
pump recommendation

How the Valve Operates

When air pressure at 70 psi (4.8 bar) is applied, the piston shifts the spool ① to the open position, allowing fluid to flow. At the end of the cycle, spring force on the piston ② shifts the spool to the closed position, stopping fluid flow. During the closing action, the 736HPA-NV provides snuff-back of fluid for clean cutoff.

The stroke adjustment ③ can be used to regulate snuff-back to an amount appropriate for the fluid being dispensed. Stroke adjustment can also be used to reduce fluid surge when the valve opens to ensure consistent bead widths and dot profiles. The stroke is adjusted by moving the stroke limit stop:

1. To access the stop, first remove the air input hose from the push-in air coupling by pushing down on the release ring while pulling up on the tubing.
2. Insert the 1/8" Allen wrench through the air coupling and engage the stroke limit stop.
3. Adjust the stop toward or away from the piston to vary the stroke. To decrease the amount of opening surge and closing snuff-back, extend the limit stop by turning the wrench clockwise. To increase the amount of surge and snuff-back, retract the limit stop by turning the wrench counterclockwise.

Note: Adjusting the stroke does not affect the flow rate.

4. Install the air input hose by pushing the hose into the coupling.

Note: For striping applications, fluid surge can be reduced further by lowering the valve operating air pressure down to, but not below, 40 psi (2.7 bar).

When dispensing very thick fluids at high cycle rates, the double-acting feature ensures rapid closure. A double-actuating air input ④ is provided on the side of the air cylinder to allow double-acting operation using air pressure to both open and close the valve.

The amount of fluid dispensed is determined by valve open-time, fluid pressure, dispensing tip size and fluid viscosity.

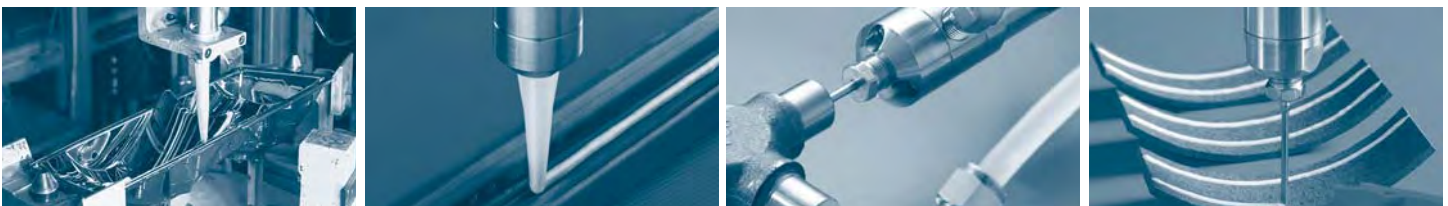
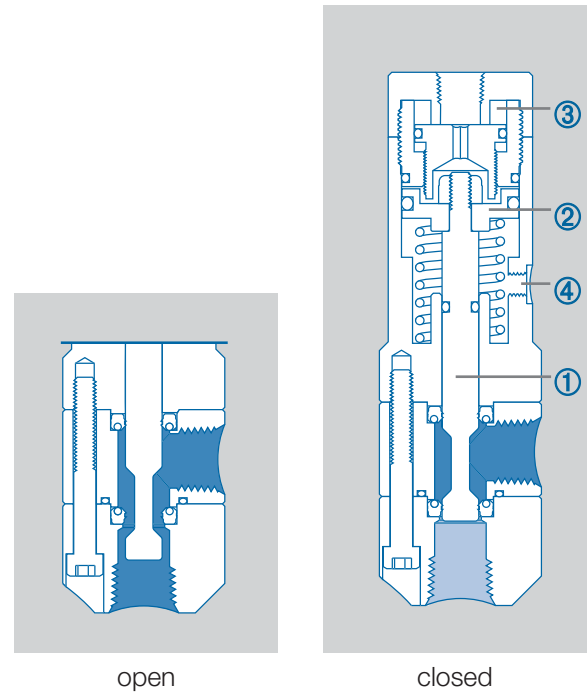

Specifications

General

Size: 116.1 mm length x 34.9 mm diameter
(4.57" x 1.375")

Weight: 18.9 oz (537 grams)

Air cylinder body: Type 303 stainless steel

Fluid body and cap: Type 303 stainless steel

Fluid inlet thread: 1/4 NPT female

Output thread: 1/4 NPT female

Piston: Hard-coated aluminum

Spool: Hardened stainless, hard-chrome coated

Spool seals: Hytrel® (Viton® optional)

Air pressure required: 70 psi (4.8 bar)

Maximum fluid pressure: 2,500 psi (172 bar)

Mounting hole: 5/16-24 UNF tapped hole or adjustable mounting block

ValveMate Concept

The ValveMate 8000 (#7022004) provides easy adjustment of valve output for maximum end-user convenience and efficiency. Valve open time is the primary control of deposit. The 8000 puts push-button adjustment of valve open time where it needs to be—at the valve.

The ValveMate 8000 features micro-processor circuitry for extremely precise control of deposit size. Feed lines can be purged, initial deposit sizes set, and adjustments made quickly and easily at the dispensing station, without stopping the production line.

Note: The EFD TT 325 and 525 XYZ automated dispensing systems have integrated ValveMate controllers for operating all EFD dispense valves.

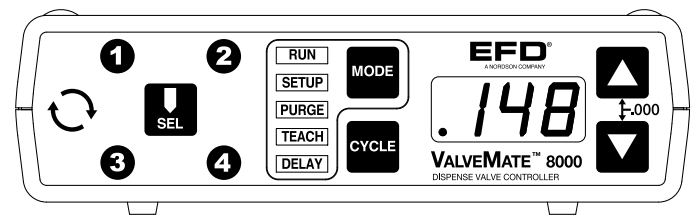

Important Note: Order your 1, 2, 3 or 4 solenoid manifold block assembly separately. Consult EFD for recommendations.

For consistent dispense valve operation and easy adjustment of valve output, EFD recommends using the ValveMate 8000 controller on all automatic, semi-automatic and benchtop applications.

The EFD TT Series positioning systems incorporate dispensing control into the main system.

Contact the EFD Dispense Valve Systems Group for details.



For EFD sales and service in over 30 countries, contact EFD or go to www.efd-inc.com

EFD, Inc.

East Providence, RI USA

USA & Canada: 800-556-3484; +1-401-434-1680

info@efd-inc.com

www.efd-inc.com

EFD International Inc.

Dunstable, Bedfordshire, UK

0800 585733 or +44 (0) 1582 666334

Ireland 00800 8272 9444

europa@efd-inc.com

www.efd-inc.com

EFD, Inc., Asia

China: +86 (21) 3866 9166

china@efd-inc.com

www.efd-inc.com/cn

Singapore: +65 6796 9630

sin-mal@efd-inc.com

Packaging - Processing

Bid on Equipment

1-847-683-7720

www.bid-on-equipment.com

Hytrel and Viton are registered trademarks of DuPont.

©2008 Nordson Corporation 736-NV-INSTALL-01 7013872 v042508