

725HF High Flow Series Dispense Valves INSTALLATION GUIDE

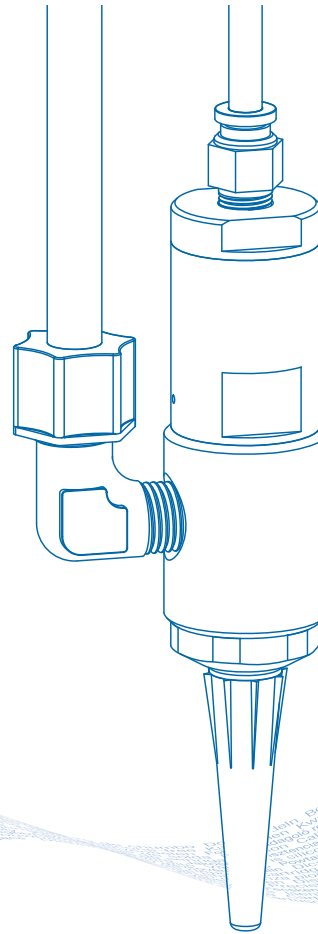

Electronic pdf files of EFD manuals are also available at www.efd-inc.com/manuals.html.

USA & Canada: 800-556-3484 or +1-401-434-1680
 Europe: 0800 585733 or +44 (0) 1582 666334
 Asia: +86 (21) 5854 2345
technical@efd-inc.com www.efd-inc.com



Introduction

The 725HF Series is simple to use and will operate many millions of cycles without maintenance.

The unique design of the 725HF Series valve provides a clean fluid cutoff with pullback for precise fluid application at high cycle rates.

Each 725HF-SS and 725HF-A valve is shipped with a dispensing tip adapter, fluid inlet fitting and 5-foot actuating air hose installed. For high-flow applications, the dispensing tip adapter can be removed for installation of 1/4 NPT metal or plastic nozzles.

The 725HF-A is identical to the 725HF-SS, except the fluid body and cap are acetal copolymer, and the shaft and the sealing-head screw are Teflon®-coated stainless steel.

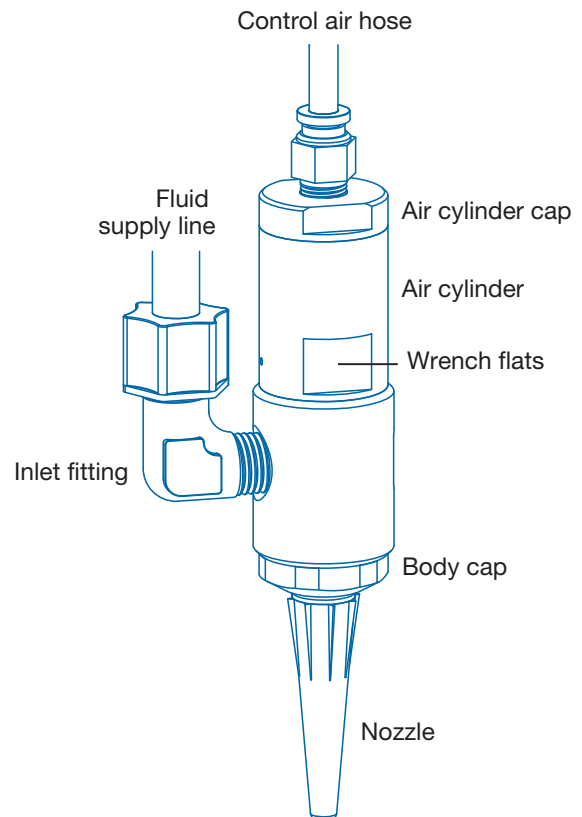

Installation

Prior to installing this valve, please read the associated reservoir and valve controller operating instructions to become familiar with the operation of all components of the dispensing system.

1. Connect the fluid feed hose to the fluid inlet fitting (#72608P is installed for use with 3/8" OD tubing and reservoir).
2. Connect the fluid supply line to reservoir. The reservoir can accept either 1/4" OD or

3/8" OD tubing using #62518PT supplied.

3. Connect valve control air hose to ValveMate™ 8000 (solenoid pack) used to control valve open time.
4. Install nozzle to the valve output.
5. Fill reservoir by pouring fluid directly into tank liner or manufacturer's bottle placed inside reservoir. Secure cover prior to setting pressure.

6. Set reservoir pressure to low for thin fluids and higher for thick fluids.
7. Place a cup under the dispensing tip or nozzle and actuate the valve until fluid lines, valve and dispensing tip are free of air.
8. Set desired flow rate by adjusting fluid reservoir pressure or changing dispensing tip or nozzle.

Important Note: Set desired deposit size by adjusting valve open time. Refer to valve controller operating manual.

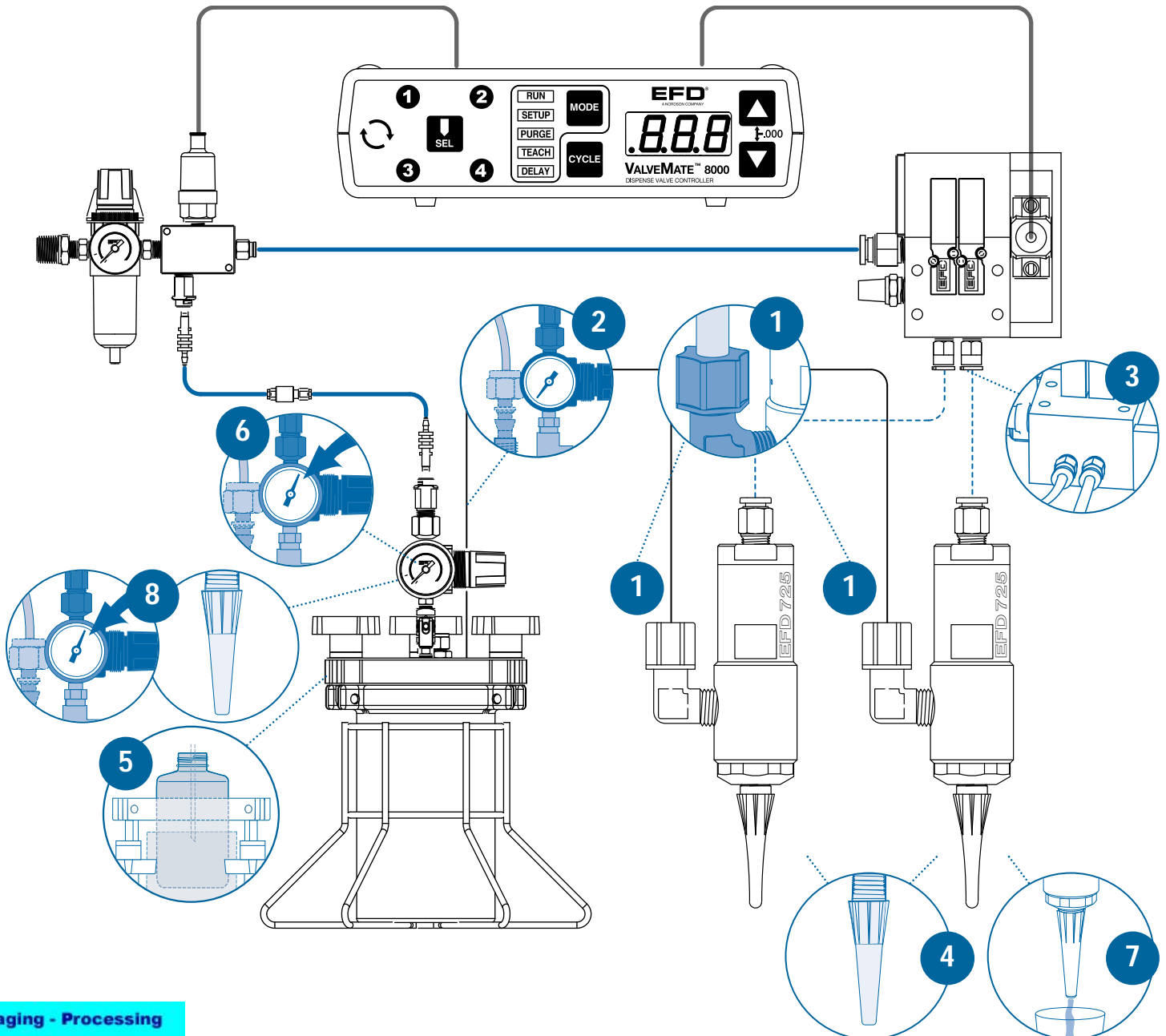

How the Valve Operates

Input air pressure at 70 psi* (4.8 bar) forces the internal piston ① to move down, causing the diaphragm seal ② to deflect and the sealing head ③ to open and permit fluid flow. When the input air pressure exhausts, the spring retracts the piston and the sealing head closes, stopping the fluid flow and pulling back a slight amount of fluid.

The amount of fluid dispensed will depend on the time the valve is open, the viscosity of the fluid, the air pressure in the fluid reservoir and the dispensing tip size.

Flow rate is a function of reservoir pressure, tip size and fluid viscosity.

* For stripes and lines, input air pressure can be lowered to eliminate opening surge.

The primary control of deposit size is the valve open time.

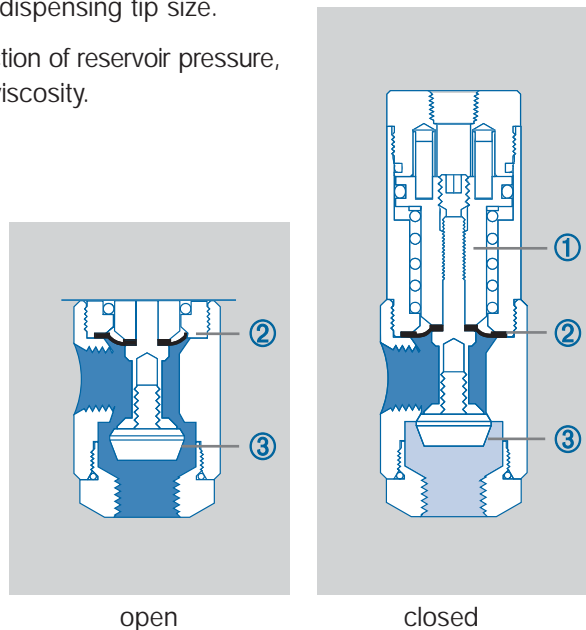

ValveMate Concept

The ValveMate 8000 provides easy adjustment of valve output for maximum end-user convenience and efficiency. Valve open time is the primary control of deposit. The 8000 puts push-button adjustment of valve open time where it needs to be—at the valve.

The ValveMate 8000 features micro-processor circuitry for extremely precise control of deposit size. Feed lines can be purged, initial deposit sizes set, and adjustments made quickly and easily at the dispensing station, without stopping the production line.

Note: The EFD Ultra® TT 325 and 525 XYZ automated dispensing systems have integrated ValveMate controllers for operating all EFD dispense valves.

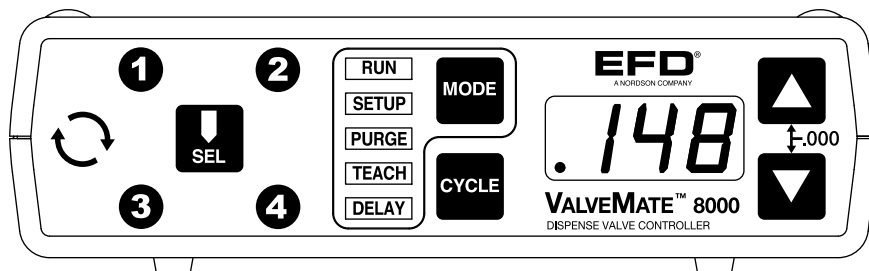

Important Note: Order your 1, 2, 3 or 4 solenoid manifold block assembly separately. Consult EFD for recommendations.

www.efd-inc.com technical@efd-inc.com USA 800-556-3484 Europe +44 (0) 1582 666334 Asia +86 (21) 5854 2345



Specifications

General

Size: 90.1 mm length x 31.1 mm diameter (3.55" x 1.22")

Valve seal/diaphragm: FDA-approved UHMW* polymer

Air cylinder body: Hard-coated aluminum

Fluid inlet thread: 1/4 NPT female

Output thread: 1/4 NPT female

Air pressure required: 70 to 90 psi (4.8 to 6.2 bar)

Maximum fluid pressure: 100 psi (6.9 bar)

Maximum operating temperature: 43°C (110°F)

725HF-SS

Weight: 295 grams (10.4 oz)

Shaft and sealing head screw: 303 stainless steel

Fluid body and cap: 303 stainless steel

Mounting hole: 5/16-24

725HF-A

Weight: 181 grams (6.4 oz)

Shaft and sealing head screw: Teflon®-coated 303 SS

Fluid body and cap: inert acetal copolymer

* Ultra High Molecular Weight

For consistent dispense valve operation and easy adjustment of valve output, EFD recommends using the ValveMate 8000 controller on all automatic, semi-automatic and benchtop applications.

The EFD Ultra TT Series positioning systems incorporate dispensing control into the main system.

Contact the EFD Dispense Valve Systems Group for details.



For EFD sales and service in over 30 countries, contact EFD or go to www.efd-inc.com/contact

EFD, Inc.

East Providence, RI USA

USA & Canada: 800-556-3484; +1-401-434-1680

info@efd-inc.com

www.efd-inc.com

EFD International Inc.

Dunstable, Bedfordshire, UK

0800 585733 or +44 (0) 1582 666334

Ireland 00800 8272 9444

europa@efd-inc.com

www.efd-inc.com

EFD, Inc., Asia

China: +86 (21) 5854 2345

china@efd-inc.com

www.efd-inc.com/cn

Singapore: +65 6796 9630

sin-mal@efd-inc.com

Teflon is a registered trademark of DuPont.

©2007 Nordson Corporation 725HF-INSTALL-01 v052307