

Piston valve systems for precise deposits of viscous fluids.

braze pastes
epoxies
grease
paste fluxes
RTV/sealants
solder resists



The 725D Series valve systems consistently dispense a wide range of medium to thick fluids, including greases and silicones.

The piston design provides a slight snuff-back at the end of the dispense cycle for positive fluid cutoff. These pneumatically operated valves are ruggedly constructed and feature a unique UHMW* polymer diaphragm that isolates the wetted components from the actuator. The UHMW* sealing head provides long wear.

The 725DA-SS provides stroke adjustment for both fluid flow and snuff-back control. The 725D-SS version is nonadjustable and provides fixed stroke travel.

*Ultra High Molecular Weight polyethylene



Features

- Positive shutoff
- End-of-cycle snuff-back
- Diaphragm life exceeds 50 million cycles
- Cycle rate exceeds 400/minute
- Excellent chemical resistance
- Low-maintenance design

Electronic pdf files of EFD manuals are also available at www.efd-inc.com/manuals.html

"Machine downtime was reduced to almost zero, and braze paste usage reduced by 40%." S&H Fabricating

www.efd-inc.com info@efd-inc.com USA 800-556-3484 Europe +44 (0) 1582 666334 Asia +86 (21) 3866 9006

Sales and service of EFD dispensing systems are available worldwide.

Packaging - Processing
Bid on Equipment
1-847-683-7720
www.bid-on-equipment.com

Piston valve systems

The complete system includes the 725D Series valve, ValveMate™ 8000 controller, the fluid reservoir and dispense tip.

Expert technical assistance and high quality standards ensure productive, trouble-free performance. EFD offers a full line of reliable dispensing systems to meet your specific application requirements.

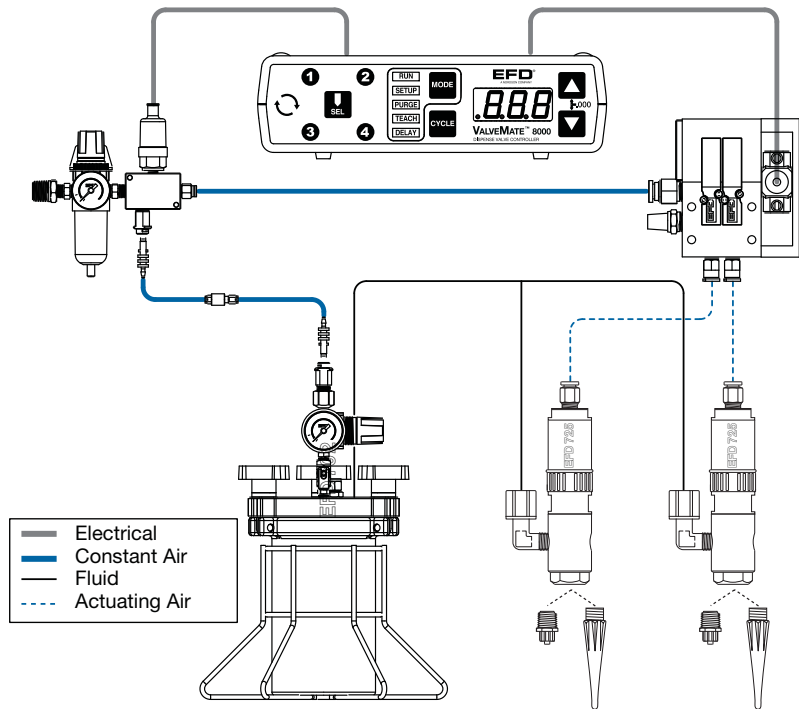

725D Series Valves

The 725D Series valves are used with ValveMate 8000 controllers or EFD TT automation system for precise, repeatable outputs. Piston action provides slight material pullback at the end of the dispense cycle for a clean fluid cutoff. Valves may be mounted in any position.

725DA-SS (stroke adjustment)

Size: 152.4 mm x 29.5 mm diameter
(6.00" x 1.16")

Weight: 326 grams (11.5 oz)

725D-SS (fixed stroke-travel)

Size: 127 mm x 28.4 mm diameter
(5.00" x 1.12")

Weight: 279 grams (9.85 oz)

Actuating air pressure required: 70 psi (4.8 bar)

Maximum fluid pressure: 100 psi (6.9 bar)

Fluid inlet thread: 1/8 NPT female

Fluid outlet: 1/4 NPT female

Mounting: (1) 1/8 NPT female blind hole or adjustable mounting block

Air cylinder body: Hard-coated aluminum

Fluid body: Type 303 stainless steel

Piston: Hard-coated aluminum

Spring: Stainless steel

Sealing head/diaphragm: UHMW* polymer, FDA-approved

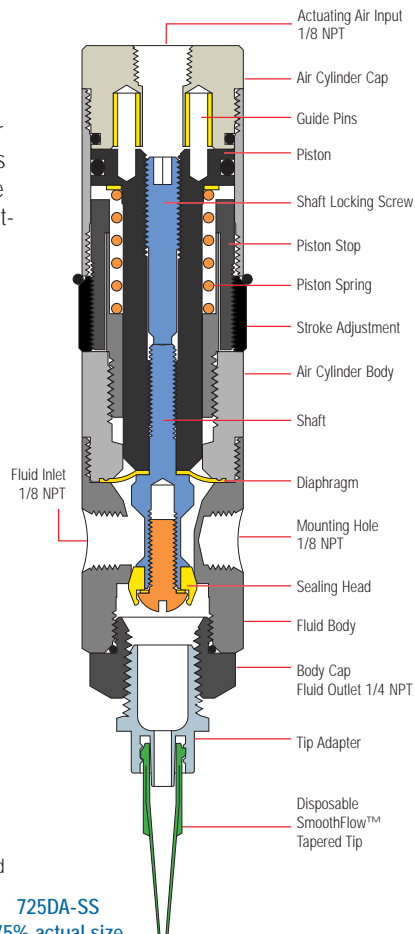

725DA-SS
75% actual size

All stainless steel parts are passivated.

*Ultra High Molecular Weight polyethylene



Packaging - Processing
Bid on Equipment
1-847-683-7720
www.bid-on-equipment.com

ValveMate 8000 Controller

Valve open time is the primary control of deposit size. The ValveMate controller puts push-button adjustment of valve open time where it needs to be — at the valve.

- Multi-valve control- up to (4) valves
- Partner to Programmable Logic Controller (PLC)
- Easy deposit size control
- Increased production output
- End user convenience
- On-the-fly adjustability
- Maximum machine efficiency

Optional: XYZ Dispensing System

The EFD TT xyz dispensing system incorporates all functions of the ValveMate. Compact 3-axis tabletop system offers consistent deposit repeatability. Work area: 325 x 325 x 100 mm or 525 x 525 x 100 mm.

Fluid Reservoirs

EFD reservoirs are supplied with precision, constant-bleed regulators to ensure consistent fluid pressure to the valve.

Tank reservoirs are available in 1.0, 5.0 and 19.0 liter capacities. Optimum™ Retainer Systems and Cartridges are available from 2.5 to 32 ounces (75cc to 950cc).

Dispense Tips

Tip selection is critical to achieve optimum valve performance. 725D Series valves are packaged with an Ultra dispensing tip kit for maximum fluid control. The kit includes smooth-flow tapered tips in sizes from 14 to 25 gauge, precision stainless steel tips in sizes from 14 to 21 gauge, and tip caps.

For high flow rates, 1/4 NPT one-piece polyethylene nozzles are available.



For EFD sales and service in over 30 countries, contact EFD or go to www.efd-inc.com

EFD, Inc.

East Providence, RI USA

USA & Canada: 800-556-3484; +1-401-431-7000

info@efd-inc.com

www.efd-inc.com

EFD International Inc.

Dunstable, Bedfordshire, UK

0800 585733 or +44 (0) 1582 666334

Ireland 00800 8272 9444

europa@efd-inc.com

www.efd-inc.com

EFD, Inc., Asia

China: +86 (21) 3866 9006

china@efd-inc.com

www.efd-inc.com/cn

Singapore: +65 6796 9522

sin-mal@efd-inc.com

Teflon is a registered trademark of DuPont.
©2009 Nordson Corporation v041409