

# 702 Series Diaphragm Valve

## INSTALLATION GUIDE



Electronic pdf files of EFD manuals are also available at [www.efd-inc.com/manuals.html](http://www.efd-inc.com/manuals.html).

Asia: +86 (21) 3866 9006  
 Europe: 0800 585733 or +44 (0) 1582 666334  
 USA & Canada: 800-556-3484 or +1-401-431-7000  
[technical@efd-inc.com](mailto:technical@efd-inc.com) [www.efd-inc.com](http://www.efd-inc.com)

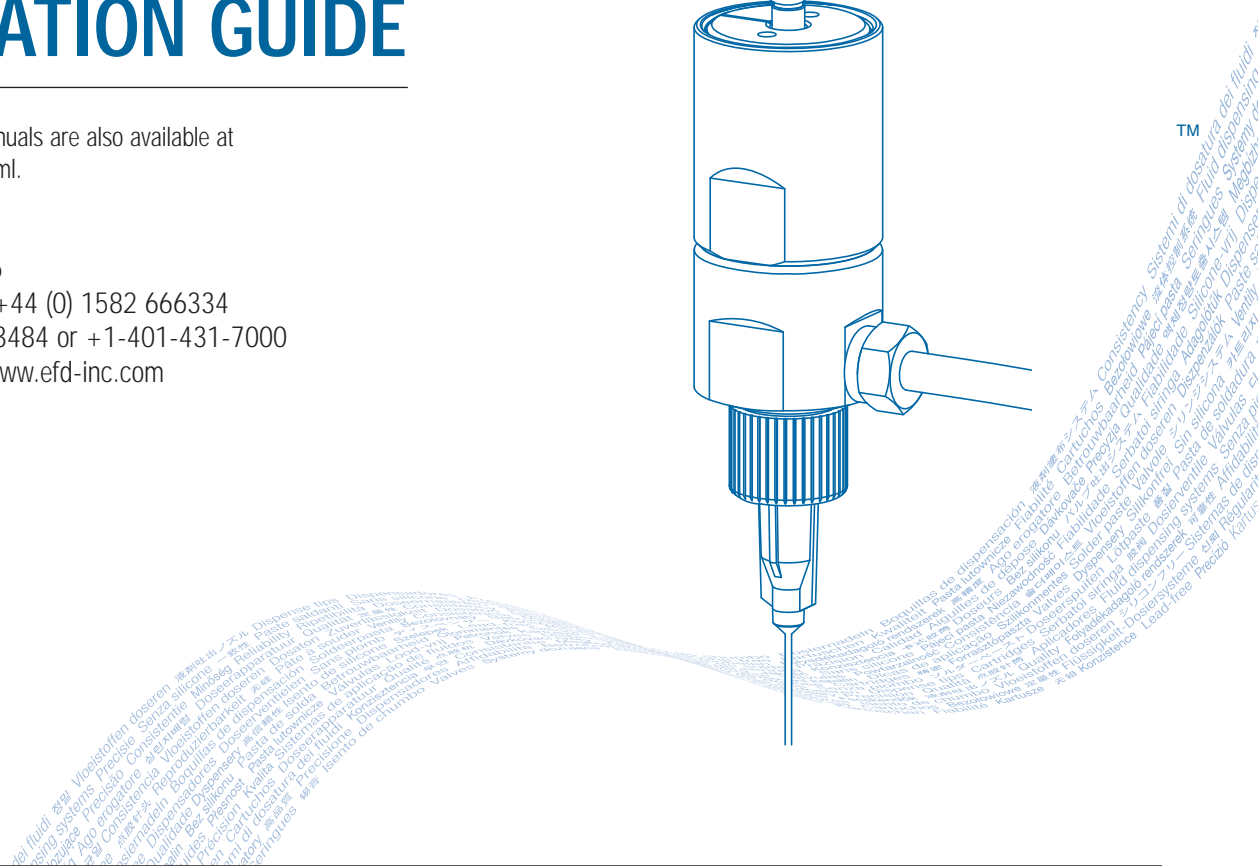
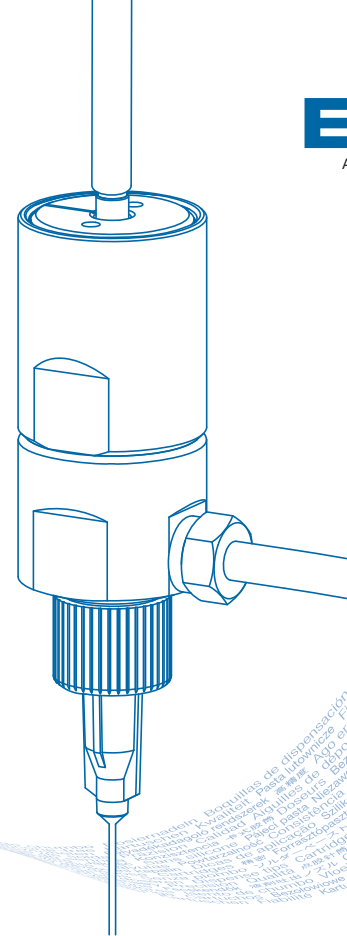

## Introduction

The 702 Series diaphragm valve is simple to use and will operate many millions of cycles without maintenance. The 702 Series incorporates a compact, precise, adjustable diaphragm for dispensing low to medium viscosity fluids.

The 702 Series has a unique flat seat that enables the valve to provide full flow at one half the stroke of a standard EFD 750 Series valve. This design also reduces turbulence and provides bubble-free dispensing of dyes and UV-cure resins used in the optical media and other industries. The central control air allows the valve to obtain its small size.

Each valve is shipped with a stroke control adjustment key.

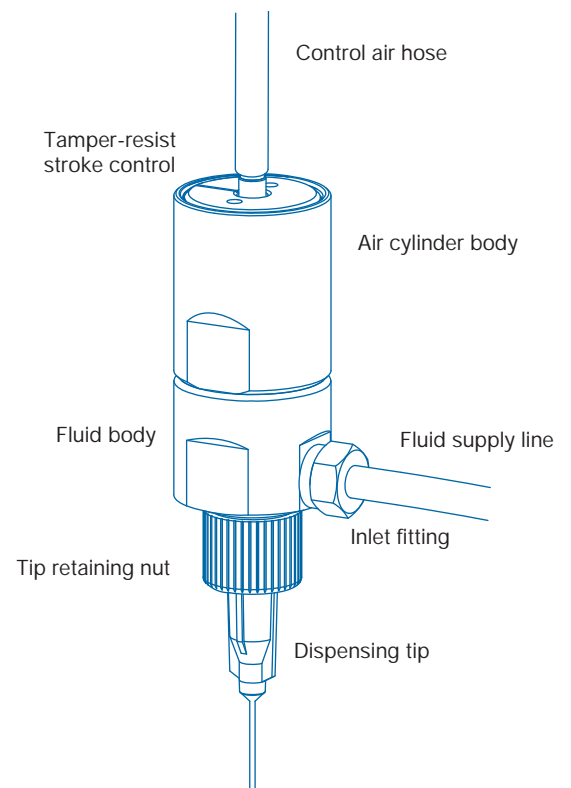

To order 702V-SS Diaphragm Valve, refer to part #7020683.  
 To order 702M-SS Diaphragm Valve, refer to part #7020679.  
 To order 702V-A Diaphragm Valve, refer to part #7020680.  
 To order 702V-T Diaphragm Valve, refer to part #7013243.

**Packaging - Processing**  
**Bid on Equipment**  
 1-847-683-7720  
[www.bid-on-equipment.com](http://www.bid-on-equipment.com)

# Installation

Prior to installing this valve, please read the associated reservoir and valve controller operating instructions to become familiar with the operation of all components of the dispensing system.

1. Connect fluid supply line to valve. Install M5 exterior thread fluid fitting. (Not supplied with 702M model.)
2. Connect the fluid supply line to reservoir.
3. Connect valve control air hose to ValveMate™ 8000 (solenoid pack) used to control valve open time.
4. Choose a dispensing tip—small tips (20 gauge) for low-viscosity fluids and larger (14 gauge) for higher viscosities. We recommend EFD PTFE-coated tips for the 702M-SS model.
5. Fill reservoir by pouring fluid directly into tank liner or manufacturer's bottle placed inside reservoir. Secure cover prior to setting pressure.
6. Set reservoir pressure to low for thin fluids and higher for thick fluids.
7. Set the stroke control starting with no more than 1/2 turn open from closed position (full clockwise). \*
8. Place a cup under the dispensing tip and actuate the valve until fluid lines, valve and dispensing tip are free of air.
9. Set desired flow rate by adjusting fluid reservoir pressure or changing dispensing tip.

**Important Note:** for PTFE Teflon® diaphragm - do not overtighten the stroke adjustment or open more than 1/2 turn. Open more than 1/2 turn, can result in dramatic reduction of diaphragm cycle life.

\* For UHMW diaphragm - do not overtighten the stroke adjustment or open it more than one full turn. If open more than one turn, pressurized liquid could force open the diaphragm seal, resulting in continuous liquid flow.

**Important Note:** Set desired deposit size by adjusting valve open time. Refer to valve controller operating manual.

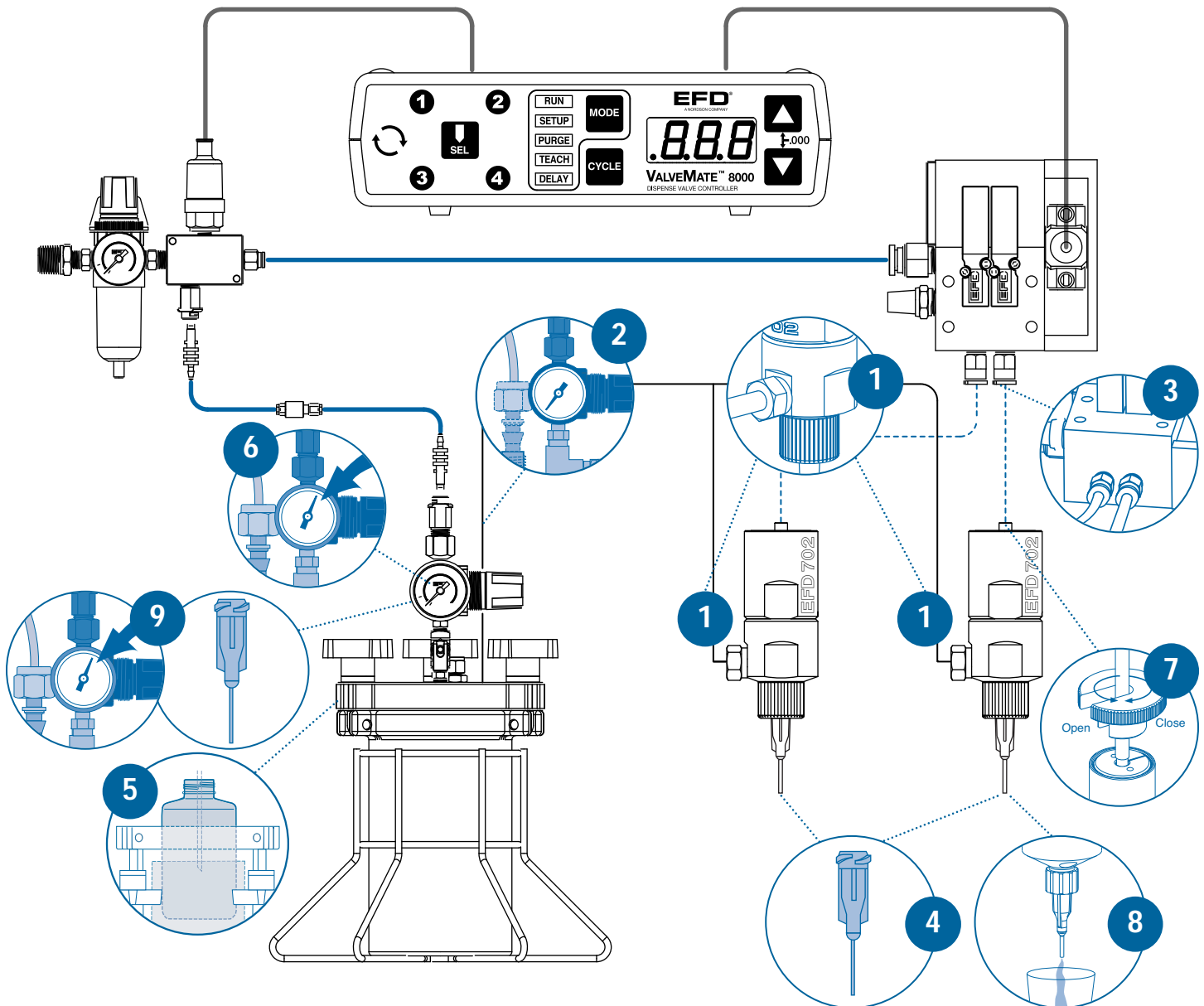

# How the Valve Operates

Input air pressure at 70 psi (4.8 bar) forces the internal piston to move. The piston rod pulls open the diaphragm seal, permitting fluid flow. When the input air pressure is relieved, the spring retracts the piston and the diaphragm closes.

The amount of fluid dispensed will depend on the time the valve is open, the viscosity of the fluid, the air pressure in the fluid reservoir, the dispensing tip size and the diaphragm stroke.

Flow rate is a function of reservoir pressure, tip size and fluid viscosity.

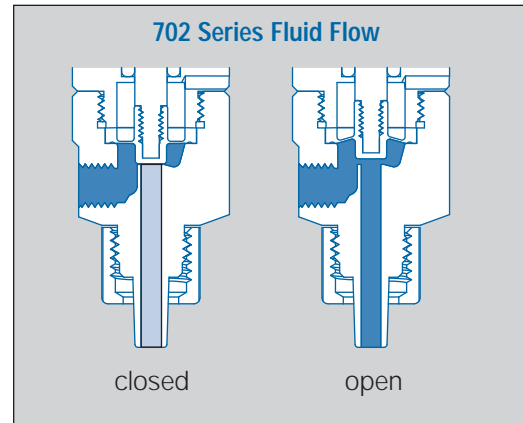

The primary control of deposit size is the valve open time.

## ValveMate Concept

The ValveMate 8000 provides easy adjustment of valve output for maximum end-user convenience and efficiency. Valve open time is the primary control of deposit. The 8000 puts push-button adjustment of valve open time where it needs to be—at the valve.

The ValveMate 8000 features micro-processor circuitry for extremely precise control of deposit size. Feed lines can be purged, initial deposit sizes set, and adjustments made quickly and easily at the dispensing station, without stopping the production line.

**Note:** The EFD® TT 325 and 525 XYZ automated dispensing systems have integrated ValveMate controllers for operating all EFD dispense valves.

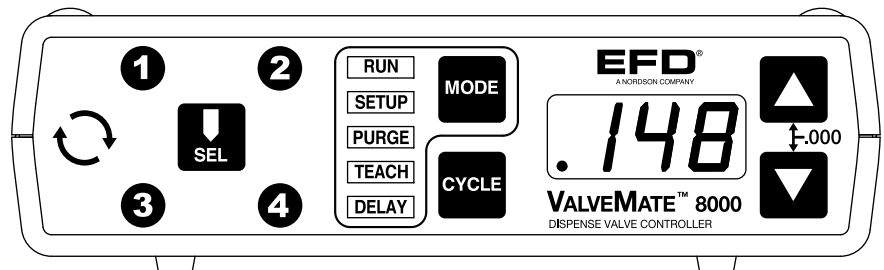

**Important Note:** Order your 1, 2, 3 or 4 solenoid manifold block assembly separately. Consult EFD for recommendations.

www.efd-inc.com technical@efd-inc.com USA 800-556-3484 Europe +44 (0) 1582 666334 Asia +86 (21) 3866 9006



# Specifications

**Diaphragm:** UHMW\* polyethylene or PTFE Teflon®

**Air pressure required:** 70 to 90 psi (4.8 to 6.2 bar)

**Maximum fluid pressure:** 70 psi (4.8 bar)

**Maximum operating temperature:** 43°C (110°F)

**Mounting:** Specify EFD part #7020507

**Size:** 63.5 mm x 19.1 mm (2.5" length x 0.75" diameter)

**Weight:** 49.3 grams (1.74 oz)

**Fluid body:** Type 303 stainless steel or acetal copolymer

**Air cylinder body:** Type 303 stainless steel

**Free flow orifice:** 2.4 mm (.09" diameter)

**Fluid inlet thread:** M5

**Tip retaining nut:** Standard for EFD dispense tips

\* Ultra High Molecular Weight

For consistent dispense valve operation and easy adjustment of valve output, EFD recommends using the ValveMate 8000 controller on all automatic, semi-automatic and benchtop applications.

The TT Series positioning systems incorporate dispensing control into the main system.

Contact the EFD Dispense Valve Systems Group for details.



For EFD sales and service in over 30 countries, contact EFD or go to [www.efd-inc.com](http://www.efd-inc.com)

**EFD, Inc.**

East Providence, RI USA

USA & Canada: 800-556-3484; +1-401-431-7000

[info@efd-inc.com](mailto:info@efd-inc.com)

[www.efd-inc.com](http://www.efd-inc.com)

**EFD International Inc.**

Dunstable, Bedfordshire, UK

0800 585733 or +44 (0) 1582 666334

Ireland 00800 8272 9444

[europa@efd-inc.com](mailto:europa@efd-inc.com)

[www.efd-inc.com](http://www.efd-inc.com)

**EFD, Inc., Asia**

China: +86 (21) 3866 9006

[china@efd-inc.com](mailto:china@efd-inc.com)

[www.efd-inc.com/cn](http://www.efd-inc.com/cn)

Singapore: +65 6796 9522

[sin-mal@efd-inc.com](mailto:sin-mal@efd-inc.com)

The Wave Design is a trademark of Nordson Corporation.

©2009 Nordson Corporation 702-INSTALL-01 (SAP#) 7020650 v031809

To order 702V-SS Diaphragm Valve, refer to part #7020683.  
To order 702M-SS Diaphragm Valve, refer to part #7020679.  
To order 702V-A Diaphragm Valve, refer to part #7020680.  
To order 702V-T Diaphragm Valve, refer to part #7013243.