

Contents

Safety Warnings	3-5
615DT Exploded View	6
615DT Specifications/Replacement Parts	7
626DT Exploded View.....	8
626DT Specifications/Replacement Parts	9
Pressure Relief Procedure	10-11
Setup/Refilling	12-13
Wetted Materials List/Troubleshooting	14
Maintenance & Cleaning/Accessories	15
Declaration of Conformity.....	Back Cover

The 615DT and 626DT Series Reservoirs' compliance with Pressure Equipment Directive 97/23/EC has been certified by TÜV Rheinland of North America.

P/N 615DT - TÜV Certificate No. 3027543-01

P/N 626DT - TÜV Certificate No. 3027543-02

This manual is for the express and sole use of EFD purchasers and users, and no portion of this manual may be reproduced in any form.

Safety Warnings

Halogenated Hydrocarbon Fluid Hazard

NEVER USE halogenated hydrocarbon solvents or fluids containing such solvents in this equipment. Examples of halogenated hydrocarbon solvents are: 1,1,1 trichloroethane, methylene chloride, fluids with the prefix "fluoro-", "chloro-", "bromo-" or "iodo-", etc. These solvents can cause an explosion when used with aluminum components in a pressurized fluid pumping system. The resulting explosion may cause death, serious bodily injury or substantial property damage.

Pressurized Equipment Hazard

High pressure fluid can cause serious injury. This equipment is for professional use only. Observe all warnings. Read and understand all applicable instruction manuals before placing equipment into service.

Equipment Misuse Hazard

GENERAL SAFETY – Any use of the reservoir and related accessories not consistent with that described in this manual, such as modifying or removing parts, over-pressurizing, using incompatible fluids and chemicals, or using worn, damaged or incompatible parts can cause them to rupture resulting in serious bodily injury, including fluid splashed in the eyes or on the skin, or fire, explosion or other property damage.

NEVER alter or modify any part of this equipment, as doing so may cause it to malfunction.

CHECK all reservoir components regularly and replace any worn or damaged parts with only EFD supplied or approved parts. **BE SURE** that all dispensing equipment and accessories are rated to withstand the maximum operating pressure of the reservoir.

Personal Protective Equipment

Wear all protective eyewear, gloves, clothing and respirator as recommended by the manufacturer of the fluid used.

System Pressure

NEVER exceed the maximum reservoir pressure of 6.9 bar gauge (100 psi). The maximum supply pressure to the reservoir regulator must not exceed 10.4 bar gauge (150 psi).

BE SURE that all dispensing equipment and accessories are rated to withstand the maximum operating pressure of the reservoir.

If an EFD five-micron filter regulator #2000F755 is not used, be certain your plant air is properly filtered and dry. Oil or particulate in the air supply line can cause erratic performance and can contaminate the fluid to be dispensed if it is not properly filtered.

Fluid Compatibility

BE SURE that all fluids, including their vapors, contained in the reservoir are compatible with all materials on the wetted materials list on page 14 of this manual. Read the fluid manufacturer's literature, including the MSDS (Material Safety Data Sheet) and observe all warnings before pouring the fluid into the reservoir.

Fill Level

DO NOT overfill the reservoir. The recommended maximum fill level is 38.1 mm (1.5") below the top of the liner.

Tipping and Dropping Hazard

BE SURE that the reservoir is placed on a hard, level surface and that all tubing lengths are of sufficient length to allow free motion of all movable components attached to the reservoir. **DO NOT** pull on tubing to move the reservoir.

Tipping the reservoir or otherwise supporting it on its side can cause fluid to enter both the pressure regulator and pressure relief valve and interfere with their normal function. **A damaged pressure regulator and/or damaged pressure relief valve may lead to an over-pressure condition within the reservoir.** If the reservoir tips or the pressure regulator and/or pressure relief valve otherwise become blocked, they must be **replaced** with EFD supplied or approved parts before returning to service.

Dropping the reservoir from any height can damage the pressure regulator, pressure relief valve, and fittings and/or compromise the integrity of the reservoir body and cover. **A damaged pressure regulator and/or damaged pressure relief valve may lead to an over-pressure condition within the reservoir. A damaged reservoir body and/or cover can be an explosion hazard.** If the reservoir falls from any height, it must be thoroughly inspected for cracks or damage to the pressure regulator and/or pressure relief valve. If damage to a component is suspected, it must be **replaced** with EFD supplied or approved parts before returning to service.

Tubing Safety

Pressurized tubing can be very dangerous. Tubing whose integrity is compromised due to any kind of wear, damage or misuse can develop a leak, spraying the contents of the tank at high pressure. This spray can enter the eyes or cover the skin or cause other serious bodily injury, fire or property damage.

Before pressurizing the reservoir:

1. **BE SURE** all fluid connections to the reservoir are properly secured.
2. Examine all tubing for cuts, wear, bulges and leaks. If any of these conditions exist, replace the tubing immediately with EFD supplied or approved tubing. Do not try to repair a damaged tube.
3. **BE SURE** that the fluid to be dispensed is compatible with the tubing. Contact the fluid manufacturer and confirm that the fluid is compatible with the tubing material specified on page 15 of this manual.
4. **BE SURE** that the tubing will not be exposed to operating temperatures in excess of 50 °C (122 °F) or below 0 °C (32 °F) in the application.

615DT Exploded View

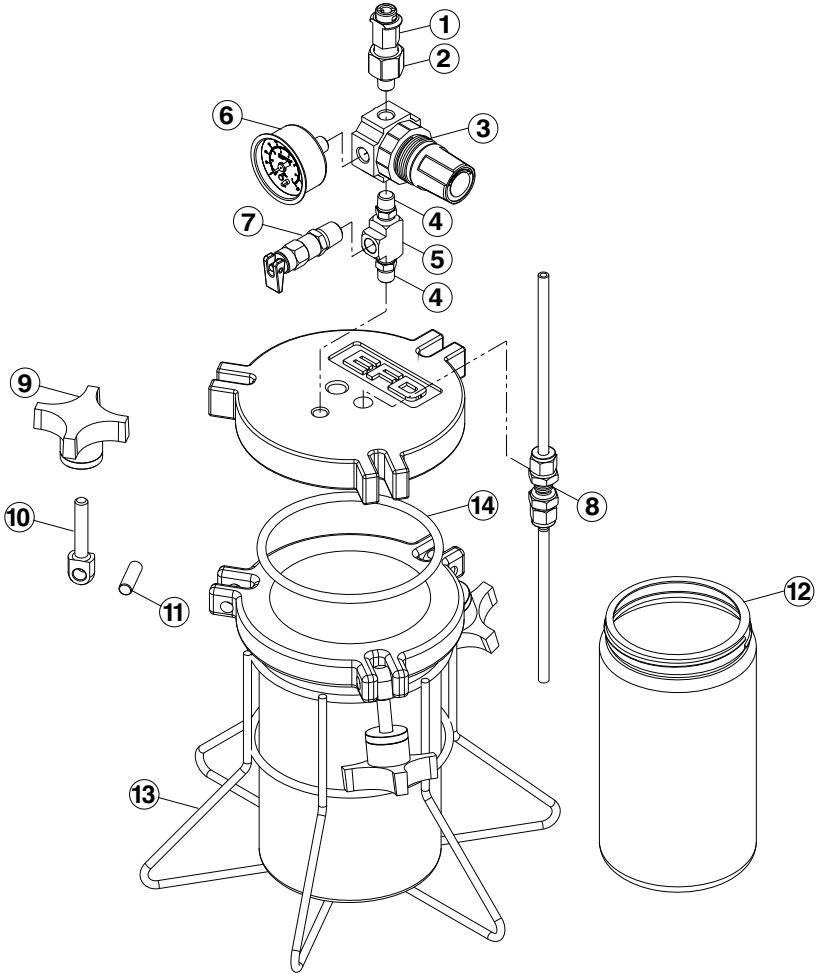

615DT Specifications

Capacity:	1 litre
Maximum Operating Pressure:	6.9 bar (100 psi)
Maximum Operating Temperature:	50 °C (122 °F)
Weight:	3.0 kg (6.60 lbs)
Height:	350 mm (13.75 inches)
Diameter (Cover Maximum):	172 mm (6.75 inches)

615DT Replacement Parts

Part number	Description	Quantity
1. 2004C	Female quick-connect	1
2. 2197A	Fitting - 1/4 NPT F x 1/8 NPT M	1
3. 2002P	Precision regulator 0-100 psi (0-6.9 bar)	1
2002A	Precision regulator 0-15 psi (0-1.0 bar)	
4. 7015	1/8 NPT M x 1/8 NPT M	2
5. A039	Tee fitting - 1/8 NPT F	1
6. 2001C	Gauge 0-100 psi (0-6.9 bar)	1
2001B	Gauge 0-15 psi (0-1.0 bar)	1
7. 615DRV	Mini relief valve	1
8. 62503PT	Fitting, bulkhead for 1/4" OD tube	1
9. 62502	Knob	3
10. 62501	Bolt	3
11. 61508	Dowel pin	3
12. 615DRL-C	Tank liner	4/box
13. 61520	Stand	1
14. 61506	Cover O-ring Buna (Standard)	1
61506V	Cover O-ring Viton®	
61506E	Cover O-ring EPR	

626DT Exploded View

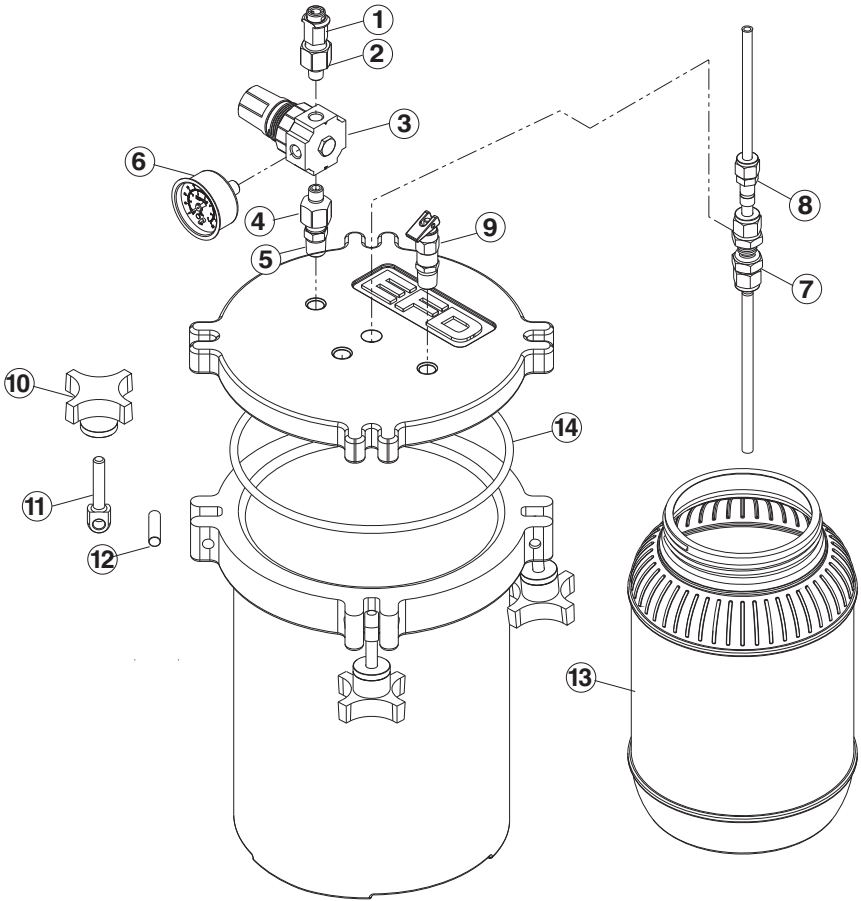

626DT Specifications

Capacity:	5 litre
Maximum Operating Pressure:	6.9 bar (100 psi)
Maximum Operating Temperature:	50 °C (122 °F)
Weight:	9.1 kg (20.1 lbs)
Height:	413 mm (16.25 inches)
Diameter (Cover Maximum):	251 mm (9.85 inches)

626DT Replacement Parts

Part number	Description	Quantity
1. 2004C	Female quick-connect	1
2. 2197A	Fitting - 1/4 NPT F x 1/8 NPT M	1
3. 2002P	Precision regulator 0-100 psi (0-6.9 bar)	1
2002A	Precision regulator 0-15 psi (0-1.0 bar)	
4. 2197A	Fitting 1/4 NPT F x 1/8 NPT M	1
5. 2185B	Fitting 1/4 NPT M x 1/4 NPT M	1
6. 2001C	Gauge 0-100 psi (0-6.9 bar)	1
2001B	Gauge 0-15 psi (0-1.0 bar)	
7. 62516PT	Fitting, bulkhead for 3/8" OD tube	1
8. 62518PT	Fitting, reducer, 3/8" to 1/4" tube	1
9. 600DRV	Air relief valve	1
10. 62502	Knob	4
11. 62501	Bolt	4
12. 62508	Dowel pin	4
13. 626DRL-C	Tank liner	4/box
14. 62506	Cover O-ring Buna (Standard)	1
62506V	Cover O-ring Viton®	
62506E	Cover O-ring EPR	

Pressure Relief Procedure

To reduce the risk of bodily injury, including fluid splashing into the eyes, **NEVER** attempt to open the reservoir without first performing this procedure.

1. Slide the shutoff valve ① on the air input hose to exhaust. (Figure 1)
2. Actuate the air relief valve ②. Hold the relief valve open until any hissing sounds end.
3. Confirm that the indicated gauge pressure is zero ③. If the gauge reads zero, slowly release the cover clamps ④ and remove the cover as shown in Figure 2.
4. **If the pressure gauge does not read zero after performing Steps 1 and 2**, remove the air input hose from the air regulator and set the regulator pressure to zero. A hissing sound should be heard from the regulator during this step. Once the gauge reads zero, return to Step 3. Do not use the reservoir until the air relief valve is replaced.

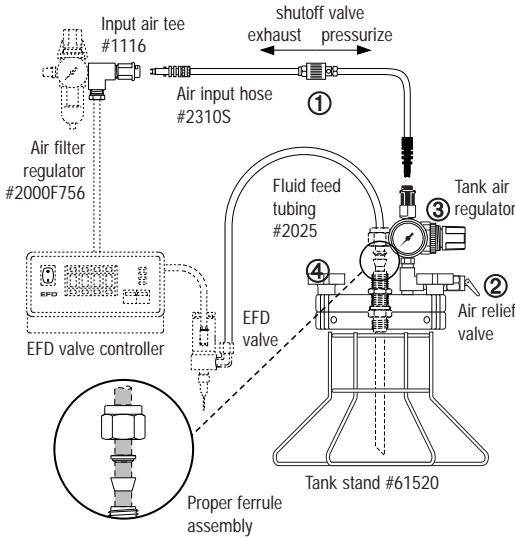

Figure 1. 615DT shown

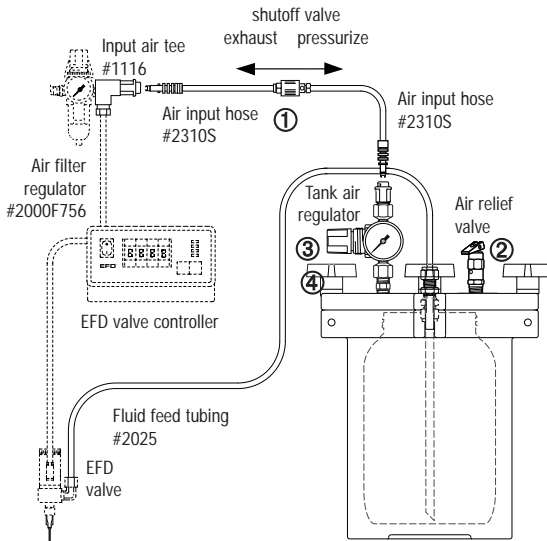

Figure 1. 626DT shown

Setup

1. Install the input air tee into the EFD five-micron filter regulator supplied with the ValveMate™ controller. Maximum pressure is 100 psi (6.9 bar). If no air filter regulator is available, specify #2000F755. (For cyanoacrylates, add coalescing filter regulator element #756FLT.)
2. Set up the EFD dispense valve and controller as described in their operating manuals.
3. Remove the tank cover and temporarily store it by reattaching one of the clamps (Figure 2). When refilling the tank, use a cup (not included) to catch any excess material that drips from the feed tube.
4. Cut the fluid feed tubing to an appropriate length plus 8" to go inside the tank. Cut one end of the feed tubing at an angle and push the tubing through the bulkhead fitting and adjust the inside length so it sits just off the bottom of the tank. Tighten the compression nut to secure the tube.

Note: 626DT series tank reservoirs can use either 1/4" or 3/8" OD fluid feed tubing. With 1/4" fluid feed tubing, use reducer fitting #62518PT (Figure 3).

5. Attach the other end of the fluid feed tubing to the dispense valve as described in the valve operating manual.
6. Fill the tank either by pouring material directly into the tank liner or by removing the liner and placing a manufacturer's bottle inside the tank.

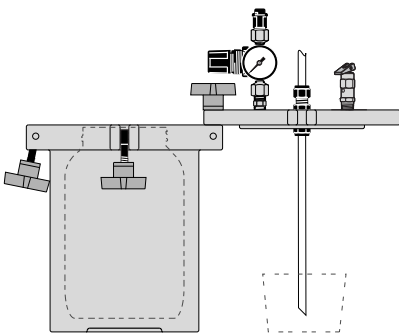

Figure 2.

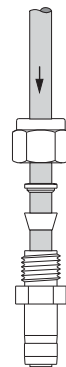

Figure 3

#62518PT reducer

7. Install the cover. If you are using a manufacturer's bottle, ensure the feed tube is inserted into the bottle. (Figure 4).
8. Tighten the cover clamps securely.
9. Attach the black quick-connect on the air hose to the black quick-connect on the tank air regulator, then attach the white quick-connect on the air hose to the input air tee. Slide the shutoff valve to the "pressurize" position.
10. Adjust the tank air regulator to a pressure sufficient to dispense material. Typical settings are 2 to 5 psi (0.1 to 0.3 bar) for low viscosity and 40 to 80 psi (2.8 to 5.5 bar) for high viscosity fluids.

Refilling

To open the tank, follow the Pressure Relief Procedure on page 10. Follow Setup steps 6-8 to refill, then close the air relief valve and slide the shutoff valve to the "pressurize" position.

Note: When pressurized, it is normal to hear a hissing sound coming from the regulator. This is due to the precision constant-bleed regulator feature.

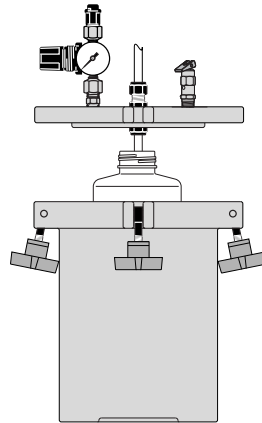

Figure 4

Wetted Materials List

The following materials come in contact with the fluid dispensed during normal use:

1. Polyethylene (fluid feed tubing and tank liner)
2. Cast Aluminum Alloy 356.0 (reservoir body and cover)

Troubleshooting

Trouble: Cannot set or maintain reservoir pressure

Possible Cause	Solution
Cover clamps not secured	Make sure all cover clamps are secured hand-tight.
Leaking feed tube bulkhead fitting	Make sure bulkhead fitting is assembled per instructions. If leak continues after proper installation, replace with new fitting.
Damaged cover O-ring seal	Replace damaged O-ring seal.
Damaged/malfunctioning air relief valve	If air relief valve is not functioning properly, it MUST be replaced before returning the reservoir to service.
Kinked air supply line	Make sure air supply line is straight and protected from other equipment.
Shutoff valve set to exhaust	Make sure shutoff valve shuttle is set to "Pressurize".
Cover seal surface dirty or damaged	Make sure cover sealing surface is free from debris or other contamination. The reservoir should be replaced if there is a cut or gouge in the sealing surface deep enough to prevent the tank from achieving its set pressure.
Damaged/malfunctioning air regulator	Replace with new air regulator.
Air supply is fluctuating	Supply system regulator is required. EFD supplies the model 2000F755 filter regulator. Set this regulator 10 psi (0.7 bar) below the lowest plant air fluctuation.

Maintenance and Cleaning

The 615DT and 626DT Series Reservoirs are very simple and reliable reservoirs that require little routine maintenance. However, the following items should be checked monthly to assure continued trouble-free operation:

1. The air relief valve must be cycled with the reservoir pressurized at least once per month. The valve should operate smoothly with normal finger pressure. If the valve requires excessive force to operate or is visibly contaminated, it must be replaced prior to returning the reservoir to service.
2. The condition of the O-ring should be checked for cuts, tears, etc. Any spills on the sealing surface of the reservoir should be wiped clean immediately with a soft, damp cloth and mild soapy water.

Accessories

Item	Part number
626DFS	Stainless steel float switch for 626DT
61524	Stainless steel float switch for 615DT
2025	1/4 OD polyethylene tubing
2025UV	1/4 OD black polyethylene tubing
2315UV	3/8 OD black polyethylene tubing
2316	3/8 OD polyethylene tubing