

BUILT RIGHT - PRICED RIGHT

EASTEY®

Presents a revolutionary concept and design for shrink banding: The Choo Choo Tunnel

Custom Conveyor with shrink band carriers, (carriers customized to each product),
on a continuous circle conveyor where product and sleeve is hand fed and hand placed.
For more information call John Belden or Sally Johnson 800-835-9344

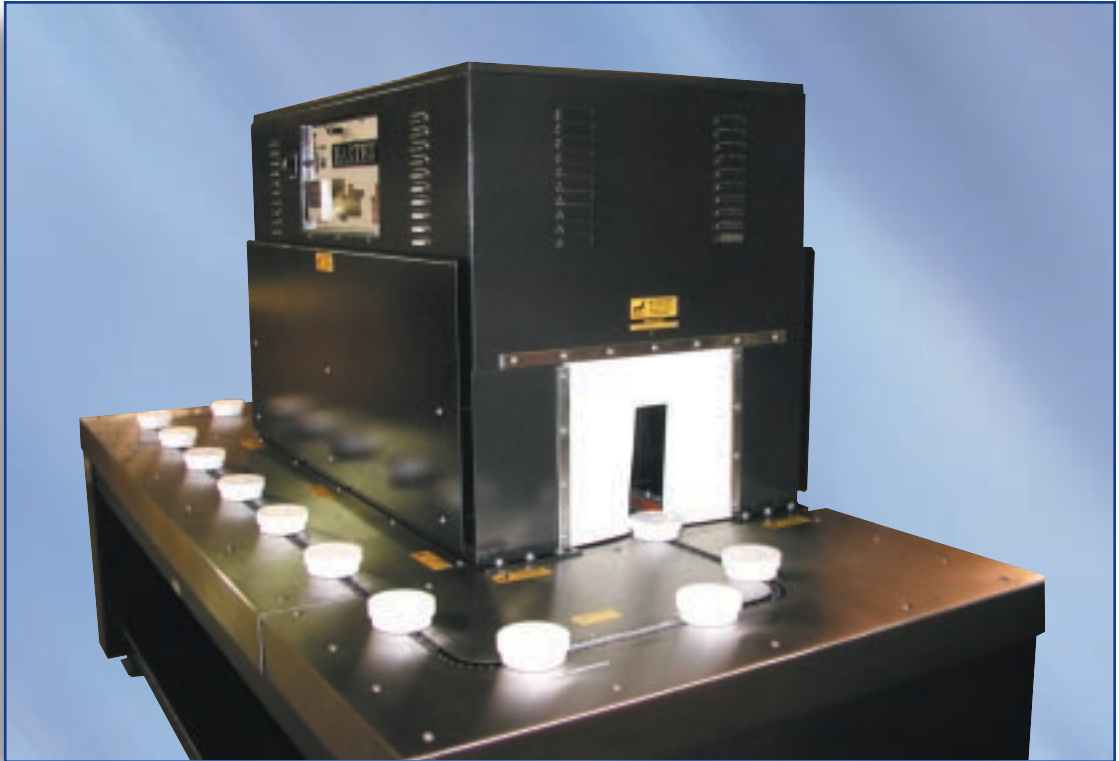

ET1610-36CC Specs:

- Chamber starts out 16" W X 10" H and is customized per the product.
- Variable speed blower motor for velocity control.
- 10 carriers - 5 product holders
- Conveyor pass height 32"
- Machine dimensions 48" W x 60.5" L x 64" H
- 230 volts, 50 amps, 1phase

ET2014CC Specs:

- Chamber starts out 20" W X 14" H and is customized per the product.
- Variable speed blower motor for velocity control.
- 18 carriers - 9 product holders
- Conveyor pass height 32"
- Machine dimensions 48" W x 100.5" L x 67" H
- 230 volts, 50 amps, 3 phase

JEFF EASTEY ENTERPRISES, INC.

21480 - 147th Avenue North, Rogers, MN 55374

www.eastey.com

(Rev. 6/07)

Packaging - Processing

Bid on Equipment

1-847-683-7720

www.bid-on-equipment.com



Made in the USA

REVISIONS

REV	DESCRIPTION	DATE	APPROVED

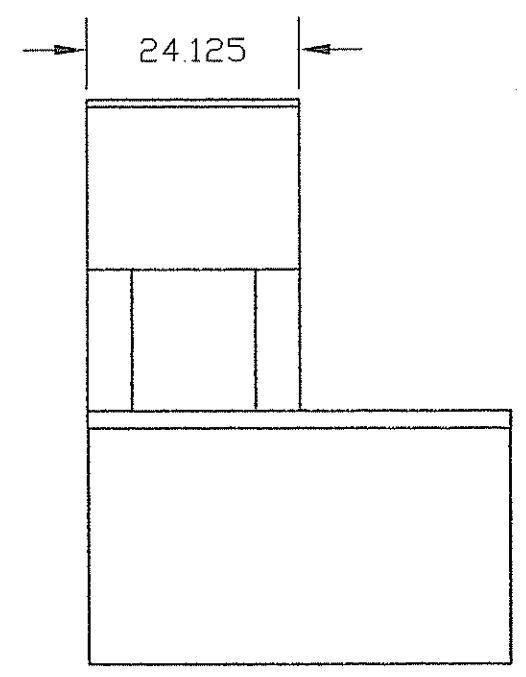
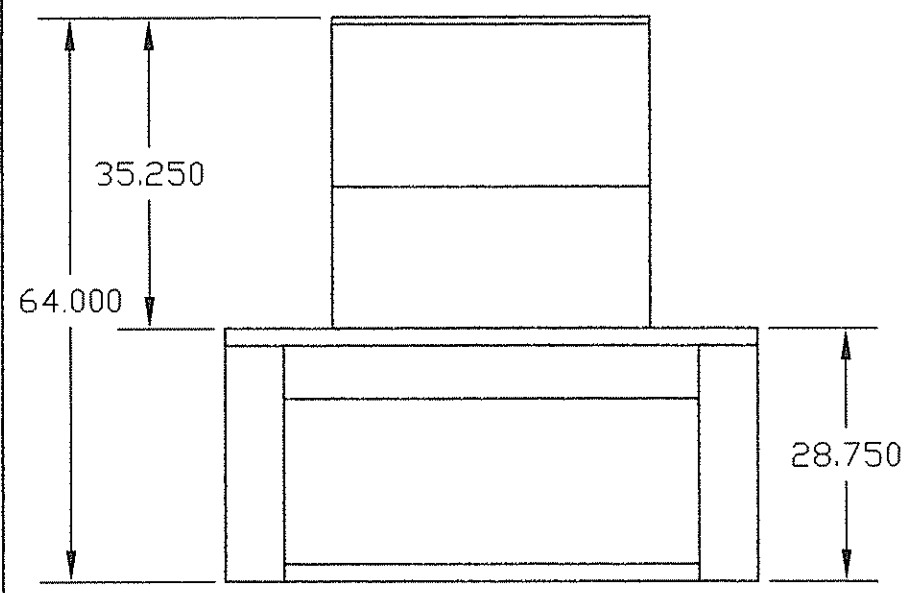
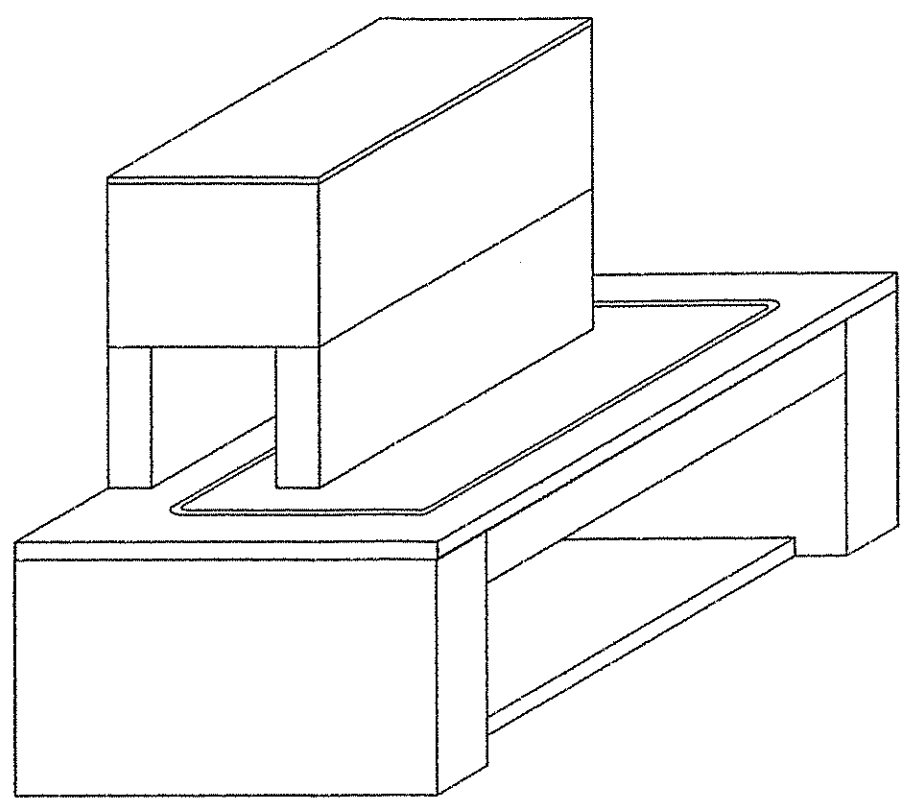
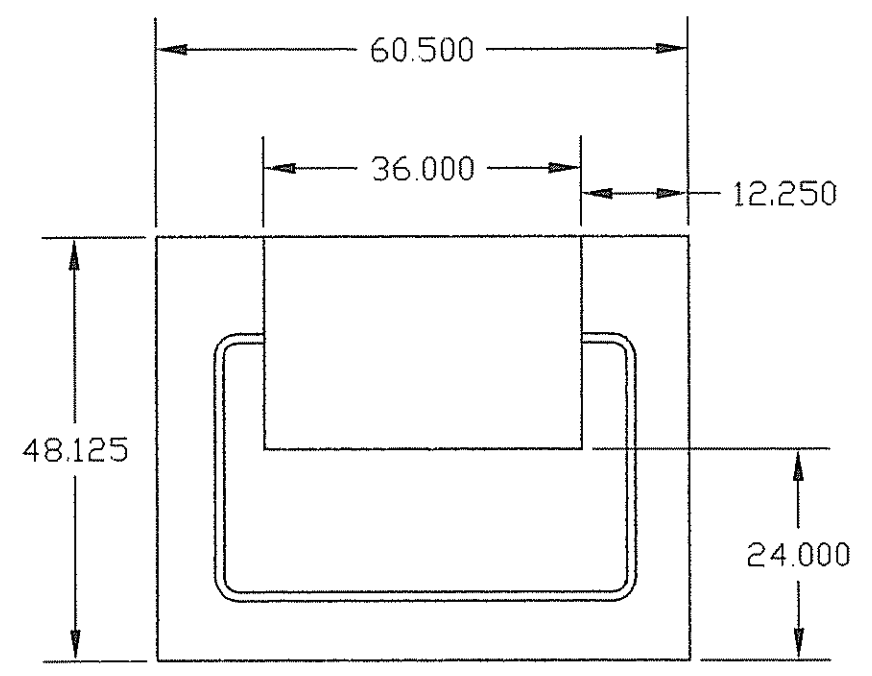

ALL DIMENSIONS ARE IN INCHES	EASTEY ENTERPRISES	Title CHOO CHOO 1610-36	
	Tolerance ±.010 (UNLESS SPECIFIED)	Scale 1:20	Material N/A
ALL TOLERANCES TO BE ±.01 UNLESS OTHERWISE SPECIFIED	Drafter TROY S.	Part Numbers CHOCHO1610-36	
FINISH - NONE	CHK By	Date 12-1-05	Part size 0.000 x 0.000